

## F210-ETN Vision Sensor

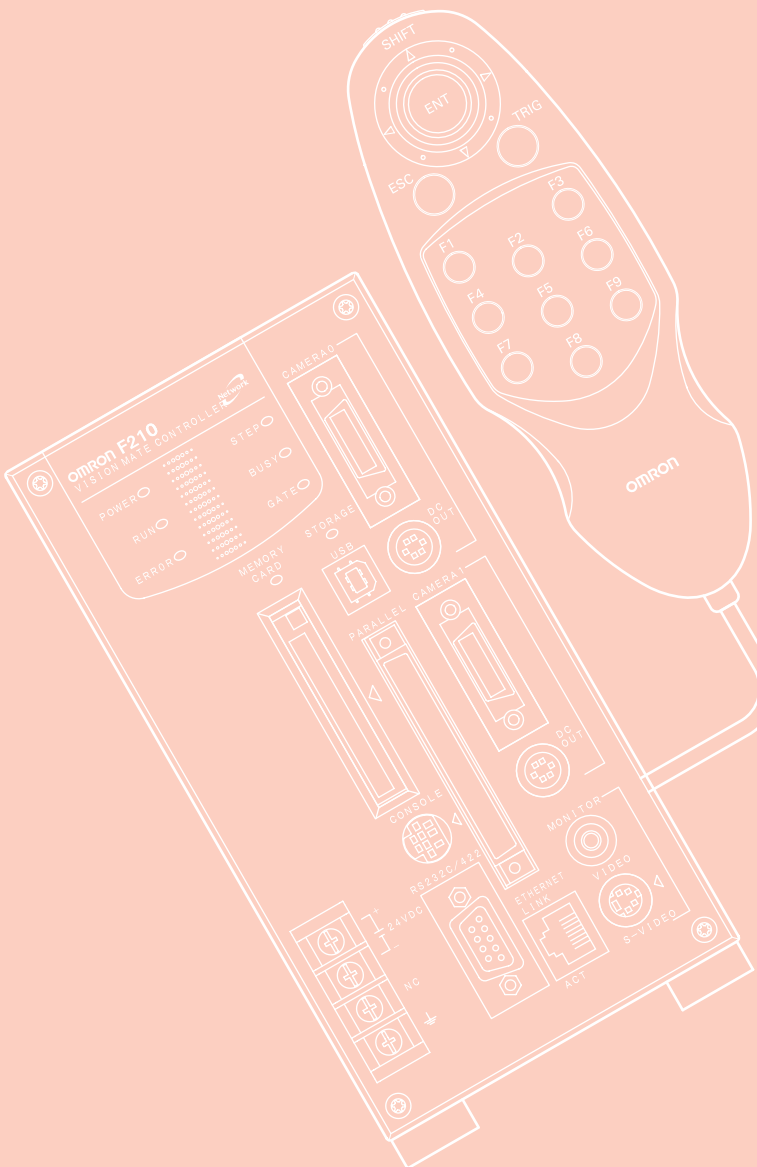

# 1

This manual provides information on system hardware and installation. Be sure to read this manual first.

# INTRODUCTION

Thank you for your purchase of this F210-C10-ETN/C15-ETN (hereinafter referred to as the Controller). This manual explains how to use the Controller. Please observe the following points when using the Controller.

- Please read and understand this manual thoroughly before using the Controller so that it is not used incorrectly.
- Please keep this manual at hand so that you can refer to it at any time.

## Operation Procedure and Reference Manual

The following shows main contents of operation steps and manuals. Select the manual suitable for your purpose and read it before starting operation.

Connecting

Wiring

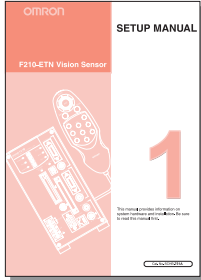

### Setup Manual

(Supplied with the Controller)

The Setup Manual provides:

- Information for safety use of controller
- Procedures from package content check and installation up to connection of controller
- Information such as functions and specifications of controller and peripheral devices.

Installing

Setting Inspection Conditions

Checking Settings and Starting Measurement

Outputting Data to External Device



### Vision Mate Series Software (CD-ROM)

#### Vision Composer Net Operation Manual

The Operation Manual provides:

- Method of operating the controller from Vision Composer Net
- Explanation of functions of Vision Composer Net

#### Tutorial Manual

The Tutorial Manual provides:

Exercises for basic operations of Vision Composer Net (※)

- ※ Two courses are available: Basic Course to learn how to perform measurement and adjustment, and Advanced Course to learn about a series of operations, starting from creation of Flow up to measurement and adjustment.

It is recommended that users begin with the Basic Course.

#### Application Software Operation Manual

The Operation Manual provides:

- Installation method of application software
- Basic operating procedures
- Setting method of each processing item
- Communication method with external devices

#### Reverse Manual

The Reverse Manual provides:

Examples of vision sensor use  
Useful methods for vision sensor use

#### Customize Manual

The Customize Manual provides the information necessary for customization and explains the macro function.

INTRODUCTION	<b>APPLICATION CONSIDERATIONS</b> (Please Read)	INTRODUCTION
SECTION 1	Features	SECTION 1
SECTION 2	Installation and Connections	SECTION 2
SECTION 3	Lenses, Lighting, and Memory Cards	SECTION 3
SECTION 4	Connecting External Devices	SECTION 4
SECTION 5	Troubleshooting and Maintenance	SECTION 5

# Setup Manual

## Network Vision Sensor

F210-C10-ETN/F210-C15-ETN



**READ AND UNDERSTAND THIS DOCUMENT**

Please read and understand this document before using the products. Please consult your OMRON representative if you have any questions or comments.

**WARRANTY**

OMRON's exclusive warranty is that the products are free from defects in materials and workmanship for a period of one year (or other period if specified) from date of sale by OMRON.

OMRON MAKES NO WARRANTY OR REPRESENTATION, EXPRESS OR IMPLIED, REGARDING NON-INFRINGEMENT, MERCHANTABILITY, OR FITNESS FOR PARTICULAR PURPOSE OF THE PRODUCTS. ANY BUYER OR USER ACKNOWLEDGES THAT THE BUYER OR USER ALONE HAS DETERMINED THAT THE PRODUCTS WILL SUITABLY MEET THE REQUIREMENTS OF THEIR INTENDED USE. OMRON DISCLAIMS ALL OTHER WARRANTIES, EXPRESS OR IMPLIED.

**LIMITATIONS OF LIABILITY**

OMRON SHALL NOT BE RESPONSIBLE FOR SPECIAL, INDIRECT, OR CONSEQUENTIAL DAMAGES, LOSS OF PROFITS OR COMMERCIAL LOSS IN ANY WAY CONNECTED WITH THE PRODUCTS, WHETHER SUCH CLAIM IS BASED ON CONTRACT, WARRANTY, NEGLIGENCE, OR STRICT LIABILITY.

In no event shall responsibility of OMRON for any act exceed the individual price of the product on which liability is asserted.

IN NO EVENT SHALL OMRON BE RESPONSIBLE FOR WARRANTY, REPAIR, OR OTHER CLAIMS REGARDING THE PRODUCTS UNLESS OMRON'S ANALYSIS CONFIRMS THAT THE PRODUCTS WERE PROPERLY HANDLED, STORED, INSTALLED, AND MAINTAINED AND NOT SUBJECT TO CONTAMINATION, ABUSE, MISUSE, OR INAPPROPRIATE MODIFICATION OR REPAIR.

**SUITABILITY FOR USE**

THE PRODUCTS CONTAINED IN THIS DOCUMENT ARE NOT SAFETY RATED. THEY ARE NOT DESIGNED OR RATED FOR ENSURING SAFETY OF PERSONS, AND SHOULD NOT BE RELIED UPON AS A SAFETY COMPONENT OR PROTECTIVE DEVICE FOR SUCH PURPOSES. Please refer to separate catalogs for OMRON's safety rated products.

OMRON shall not be responsible for conformity with any standards, codes, or regulations that apply to the combination of products in the customer's application or use of the product.

At the customer's request, OMRON will provide applicable third party certification documents identifying ratings and limitations of use that apply to the products. This information by itself is not sufficient for a complete determination of the suitability of the products in combination with the end product, machine, system, or other application or use.

The following are some examples of applications for which particular attention must be given. This is not intended to be an exhaustive list of all possible uses of the products, nor is it intended to imply that the uses listed may be suitable for the products:

- Outdoor use, uses involving potential chemical contamination or electrical interference, or conditions or uses not described in this document.

- Nuclear energy control systems, combustion systems, railroad systems, aviation systems, medical equipment, amusement machines, vehicles, safety equipment, and installations subject to separate industry or government regulations.
- Systems, machines, and equipment that could present a risk to life or property.

Please know and observe all prohibitions of use applicable to the products.

NEVER USE THE PRODUCTS FOR AN APPLICATION INVOLVING SERIOUS RISK TO LIFE OR PROPERTY WITHOUT ENSURING THAT THE SYSTEM AS A WHOLE HAS BEEN DESIGNED TO ADDRESS THE RISKS, AND THAT THE OMRON PRODUCT IS PROPERLY RATED AND INSTALLED FOR THE INTENDED USE WITHIN THE OVERALL EQUIPMENT OR SYSTEM.

### **PERFORMANCE DATA**

Performance data given in this document is provided as a guide for the user in determining suitability and does not constitute a warranty. It may represent the result of OMRON's test conditions, and the users must correlate it to actual application requirements. Actual performance is subject to the OMRON Warranty and Limitations of Liability.

### **CHANGE IN SPECIFICATIONS**

Product specifications and accessories may be changed at any time based on improvements and other reasons.

It is our practice to change model numbers when published ratings or features are changed, or when significant construction changes are made. However, some specifications of the product may be changed without any notice. When in doubt, special model numbers may be assigned to fix or establish key specifications for your application on your request. Please consult with your OMRON representative at any time to confirm actual specifications of purchased products.

### **DIMENSIONS AND WEIGHTS**

Dimensions and weights are nominal and are not to be used for manufacturing purposes, even when tolerances are shown.

### **ERRORS AND OMISSIONS**

The information in this document has been carefully checked and is believed to be accurate; however, no responsibility is assumed for clerical, typographical, or proofreading errors, or omissions.

### **PROGRAMMABLE PRODUCTS**

OMRON shall not be responsible for the user's programming of a programmable product, or any consequence thereof.

### **COPYRIGHT AND COPY PERMISSION**

This document shall not be copied for sales or promotions without permission.

This document is protected by copyright and is intended solely for use in conjunction with the product. Please notify us before copying or reproducing this document in any manner, for any other purpose. If copying or transmitting this document to another, please copy or transmit it in its entirety.

## Precautions on Safety

### Meaning of Safety Signs and Symbols

This manual uses the following signs and symbols to ensure safe operation of F210-ETN. These signs and symbols are important for avoiding injury to people or damage to the product, so make sure they are observed.

Their meanings are given below.



**WARNING**

Cautions to indicate minor or medium injury, or serious injury or in the worst case, death, if the product is not handled correctly. It also indicates possibility of serious property damage.

### ● Signs and Symbols

	<p>Danger of Explosion This indicates the possibility of explosion under certain conditions.</p>
	<p>General Prohibition Indicates general prohibited actions.</p>

### ● WARNING



**WARNING**

A lithium battery is built into the Controller and may occasionally combust, explode, or burn if not treated properly.

Dispose of the Controller as industrial waste, and never disassemble, apply pressure that would deform, heat to 100 °C or higher, or incinerate the Controller.



Use of this product is not allowed in such applications where it is used to detect a human body either directly or indirectly to ensure safety.

Do not use this product as a sensing device for human body protection.



## Regulations and standards

The Controller conforms to the following EC directives and EN standards below.

1. EC Directive: 89/336/EEC (EMC)
2. EN Standards (European Standards)  
EN61326:1997/Annex A+A1:1998 (EMI:Class A)+A2:2001

## Precautions for Safe Use

Please observe the following precautions for safe use of the products.

### ■ Installation Environment

- Do not use the product in environments where it can be exposed to inflammable/explosive gas.
- Install the Controller so that air can flow freely through its cooling vents.

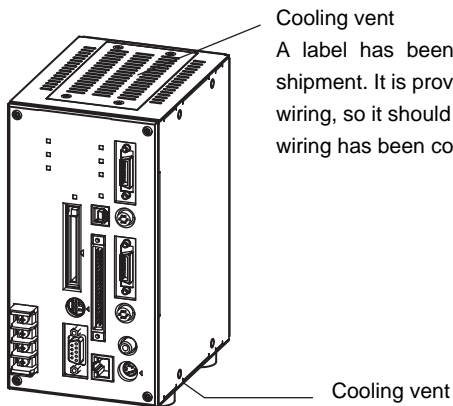

- Do not install the product close to high-voltage devices and power devices in order to secure the safety of operation and maintenance.
- Make sure to tighten all installation screws securely.

### ■ Component

- Use a Camera, Camera Cable, and Console designed specifically for the Controller.

## ■ Power Supply and Wiring

- Make sure to use the product with the power supply voltage specified by this manual.
- Use a power supply cable and crimp terminals of the specified size. Do not simply connect the twisted ends of the wires directly to the terminal block.
- Keep the power supply wires as short as possible (Max. 10 m).
- Use a DC power supply with safety measures against high-voltage spikes (safety extra low-voltage circuits on the secondary side).

 p.31

- Make sure that the load is within the rating.
- Ground the Controller's ground terminal to less than 100  $\Omega$ .
- Use a grounding point that is as close as possible and keep the ground wire as short as possible.
- Wire the Controller to the ground with a separate ground wire. To avoid grounding problems, do not share the ground wire with any other devices or wire the ground to the building's steel framing.
- Before turning on the power supply, confirm that the wiring is correct again.

## ■ Other

- Do not attempt to dismantle, repair, or modify the Controller.
- If you suspect an error or malfunction, stop using the Controller immediately, turn OFF the power supply, and consult your OMRON representative.
- Do not touch fluorescent or halogen lights while the power is ON or immediately after the power is turned OFF.
- Dispose of this product as industrial waste.



## Precautions for Correct Use

Please observe the following precautions to prevent failure to operate, malfunctions, or undesirable effects on product and product performance.

---

### Installation of the Controller

The Controller is a highly reliable vision sensor and designed to withstand use under harsh environmental conditions. However, make sure to observe the following installation precautions in order to achieve its full functionality and optimal reliability.

---

■ Install the Controller in a place that meets the following conditions:

- Surrounding temperature of 0 to +50°C
- No rapid changes in temperature (place where dew does not form)
- Relative Humidity of between 35 to 85%
- No presence of corrosive or flammable gases
- Place free of dust, salts and iron particles
- Place free of vibration and shock
- Place out of direct sunlight
- Place where it will not come into contact with water, oils or chemicals

## ■ Mount Direction

To improve heat dissipation, install the Controller in the following orientation only.

Correct

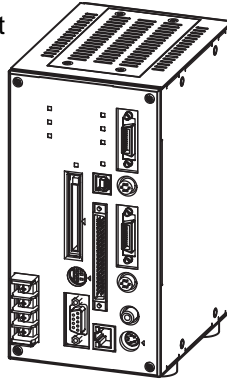

Do not install the Controller upside down as shown in the following diagram.

Incorrect

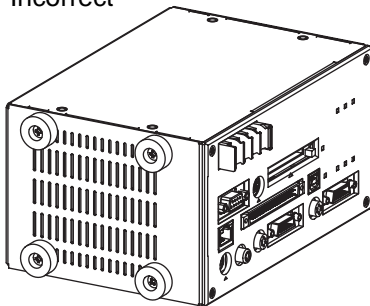

Incorrect

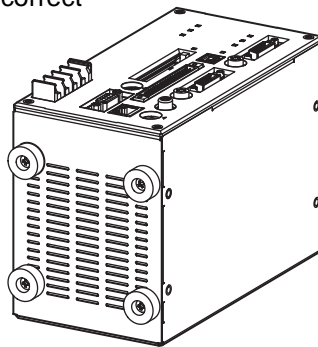

## ■ Ambient Temperature

- Maintain a minimum clearance of 50mm above and below the controller to improve air circulation.
- When installing two or more controllers side by side, maintain a minimum clearance of 10mm between each one.
- Do not install the Controller immediately above significant heat sources, such as heaters, transformers, or large-capacity resistors.
- Do not let the ambient operating temperature exceed 50°C (122°F).
- Provide a forced-air fan cooling or air conditioning if the ambient temperature is near 50°C (122°F) so that the ambient temperature never exceeds 50°C (122°F).

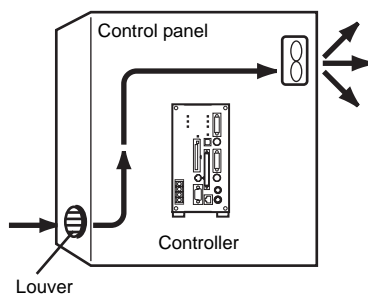

## ■ Noise Resistance

- Do not install the Controller in a cabinet containing high-voltage equipment.
- Do not install the Controller within 200mm of power cables.

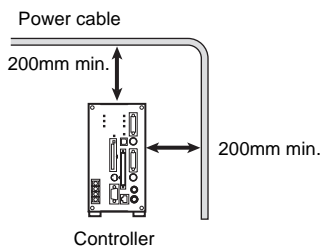

## Component Installation and Handling

### ■ Connecting Cables

Always turn OFF the Controller's power before connecting or disconnecting a camera or cable.

### ■ Handling the Camera

The Camera's case is connected to the 0V line in the internal circuits. Observe the following precautions to prevent noise interference.

- Do not ground the Camera.
- Do not remove the base attached to the Camera.
- Do not remove the ferrite core attached to the F500-VSP Camera power supply cable.

### ■ Optical axis of a special camera

The center of the optical axis varies with the camera used. Therefore, when installing the camera, always check the center of the image displayed on the monitor.

### ■ Touching Signal Lines

To prevent damage from static electricity, use a wrist strap or another device for preventing electrostatic discharges when touching terminals or signal lines in connectors.

### ■ Handling the Memory Card

- To prevent damage from static electricity, do not touch the Memory Card directly while it is installed in the Controller.
- To remove a Memory Card, turn OFF the power supply to the Card (using the menu command) or turn OFF the Controller. Press the eject button to eject the Card. The Memory Card or the Controller itself may be damaged if a Memory Card is removed while power is being supplied. (The power supply is stopped using the menu.)



CHECK!

#### Application Software

It will not be possible to start the Setup Menu if you change the contents of the Memory Card after installing it in a personal computer or other device. Never change the contents of the Card with operations such as the following:

- Changing file names
- Moving or deleting files
- Overwriting data
- Formatting

### ■ Turning OFF the Power

Do not turn OFF the power while a message is being displayed indicating that processing is being performed. Data in memory will be corrupted, and the Controller may not operate correctly the next time it is started.

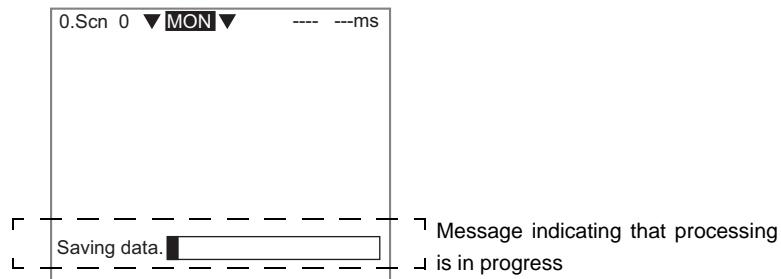

CHECK!

If the STRAGE LED is currently lit, do not turn off the power until it goes off.

### ■ Using the RESET Signal

Do not use the RESET input immediately after power is turned ON. When using the RESET input to synchronize startup timing, wait at least 1 second after the Controller's power supply is turned ON before turning ON the RESET signal.

### ■ Replacing the Battery

The Controller is equipped with a battery that backs up the clock. When the battery is low, the message "BATTERY LOW" will be displayed on the monitor at start-up. The battery must be replaced when this message is displayed. Return the Controller to your OMRON dealer for service. (The battery is not user-serviceable.)

The battery will last approximately 7 years.

# Confirming Package Contents

Check the contents of the package as soon as you receive the Controller.

It is extremely rare for components to be missing, but contact the nearest OMRON representative if any of the following items are missing.

- Controller Qty.: 1

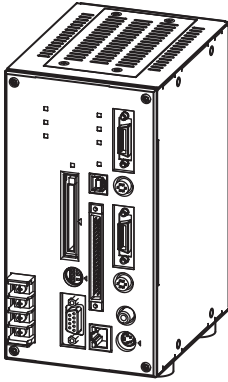

- Ferrite core for F150-KP Console or F160-KP Console Qty.: 1

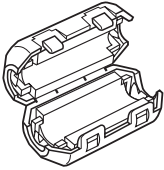

- Manual  
Setup Manual (this manual) Qty.: 1

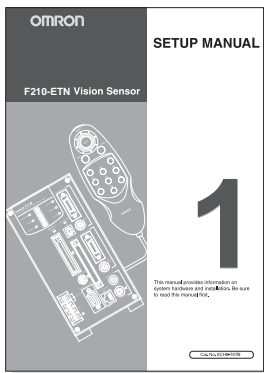

CHECK!

The Operation Manual (on CD-ROM) is packed with the Application Software for Vison Mate Series.

## Visual Aids



Indicates points that are important to achieve the full product performance, such as operational precautions and application procedures.



Indicates where to find related information.



Indicates information helpful in operation, such as the definition of terms.

# Contents

---

INTRODUCTION	2
Precautions on Safety	4
Regulations and standards	5
Precautions for Safe Use	5
Precautions for Correct Use	7
Confirming Package Contents	12
Contents	14
SECTION 1 Features	17
Vision Sensor	18
F210-ETN Features	19
SECTION 2 Installation and Connections	21
Basic System Configuration	22
Component Names and Functions	24
Mounting the Controller	25
Connecting Peripheral Devices	28
Power Supply and Ground	30
SECTION 3 Lenses, Lighting, and Memory Cards	33
CCTV Lenses	34
Lighting	37
Memory Cards	38



SECTION 4 Connecting External Devices	41
Parallel Connection Methods	42
Connecting through the Serial Interface	47
Connecting to Vision Composer Net (Via Ethernet)	53
SECTION 5 Troubleshooting and Maintenance	55
Troubleshooting	56
Q&A	60
Maintenance	61
Specifications	63
Revision History	77



# SECTION 1

## Features

 Vision Sensor	18
 F210-ETN Features	19

# Vision Sensor

---

The Vision Sensor uses a camera instead of the human eye to process images and inspect products. Visual inspections can be automated to perform complicated inspections quickly and accurately.

The OMRON Vision Sensor helps create production lines with a highly efficient inspection system, which is important to meet current demands for small-lot, variable-product production, produce greater added-value, and improve product quality.

Using the Vision Sensor yields a high return on investments by ensuring the following benefits:

- Repetitive work is reduced.
- More complicated, more precise inspections are possible.
- Inspection data management is easier (CIM, GMP, ISO9000).
- Working hours can be shortened.
- Less 3-D work (difficult, dirty, dangerous) is required.
- Work can be performed by less experienced staff.

# F210-ETN Features

Application software (sold separately) is installed in the Controller and used. Inspection conditions can be set simple and flexible using the flow-chart system.

First, install the required inspection processes from the Application Software Memory Card.

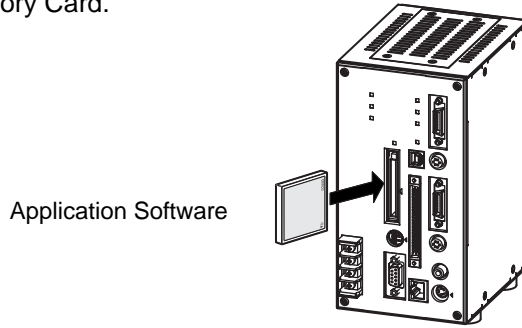

Processes in the menu can be combined freely.

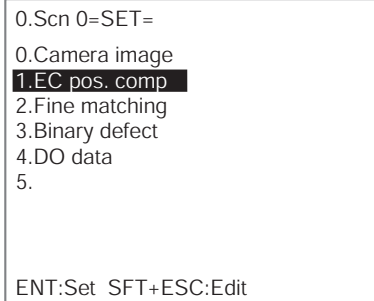

Furthermore, use of Vision Composer Net (sold separately) enables you to monitor the controller and make inspection conditions from the personal computer.

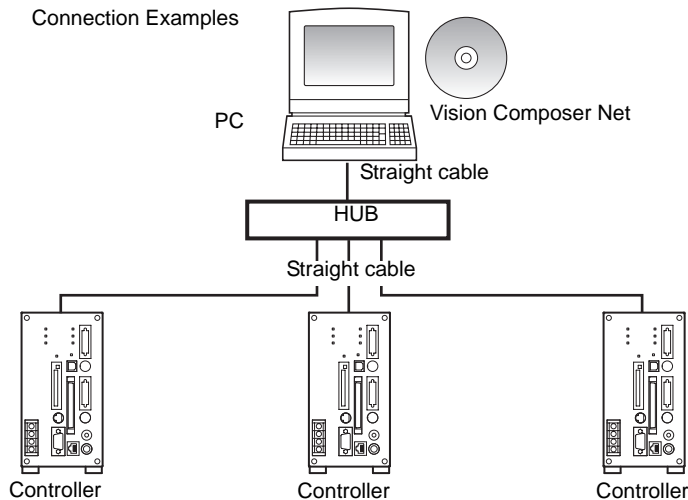



# SECTION 2

## Installation and Connections

☒ Basic System Configuration	22
☒ Component Names and Functions	24
☒ Mounting the Controller	25
☒ Connecting Peripheral Devices	28
☒ Power Supply and Ground	30

# Basic System Configuration

The following diagram shows the basic system configuration.



Some of the components shown in the configuration diagram are special OMRON products that cannot be substituted with comparable devices. The use of other products may result in damage. (These items are indicated with an asterisk.)  
**CHECK!**

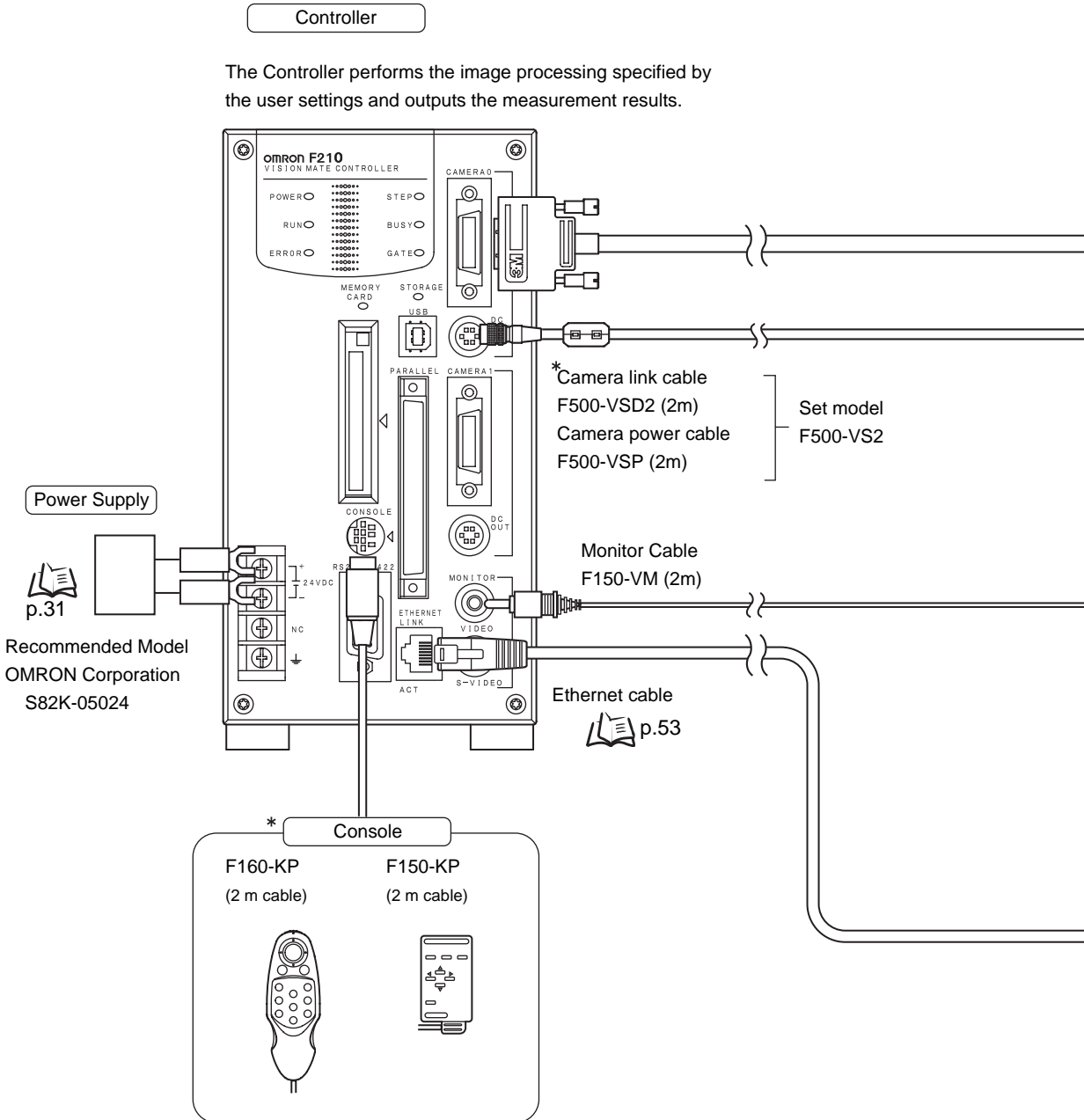



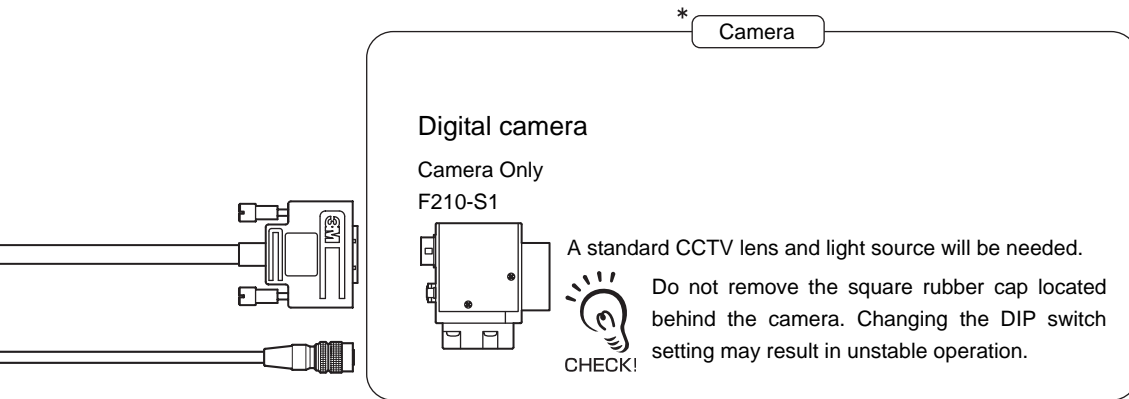

The Camera captures images of the measurement objects.  
Up to 2 Cameras can be connected to one Controller.

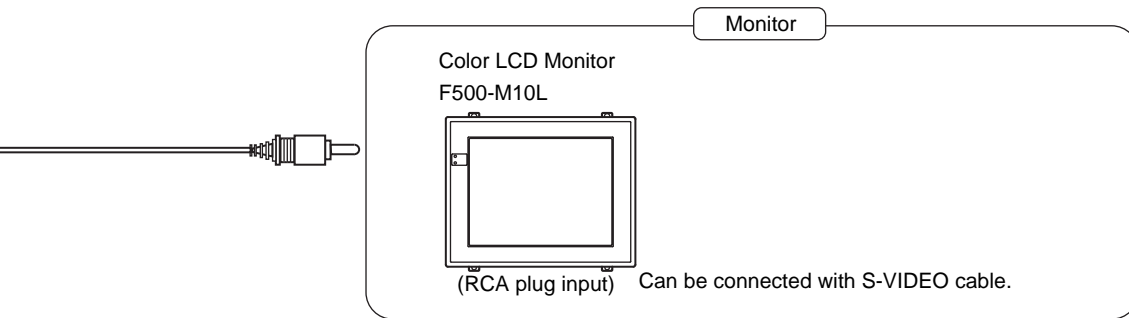

Use the Monitor to check images and display the condition-setting menus.

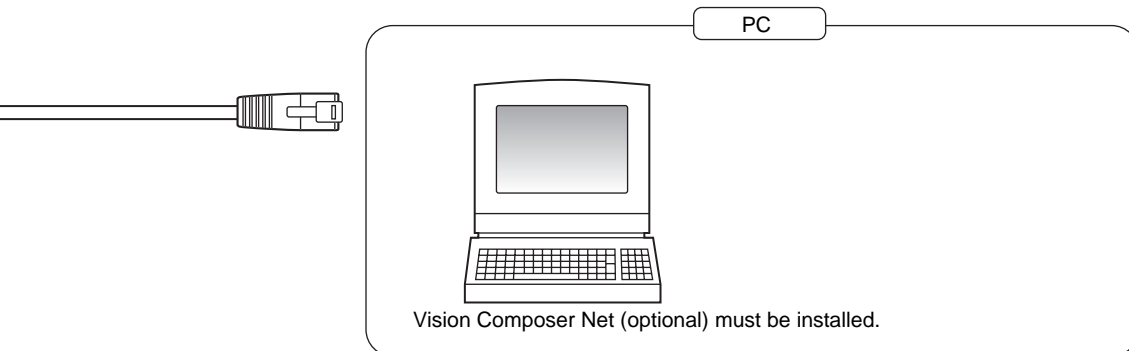

# Component Names and Functions

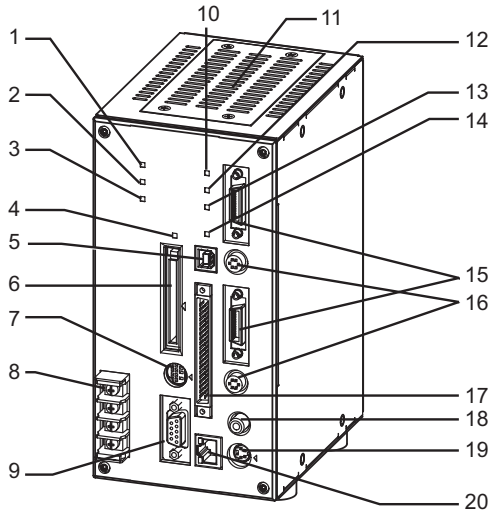

No.	Name	Function
1	POWER Indicator	Lit while the power is on.
2	RUN Indicator	Lit while the controller is in Run Mode.
3	ERROR Indicator	Lit when an error has occurred.
4	Memory card indicator	Lit when power is being supplied to the corresponding Memory Card. (The Memory Card must not be inserted or removed when this indicator is lit.)
5	USB connector	Connect a USB cable to this connector.
6	Memory Card Slots	A memory card such as the Application Software Memory Card can be inserted in this slot.
7	Console connector	Connected to a console.
8	POWER/Ground Terminal	Connect to the DC power supply and ground wire.
9	RS-232C/RS-422 Connector	Connected to an external device such as a personal computer or PLC.
10	STEP LED	Lit while the STEP signal is input.
11	Storage cover	Used to replace the storage memory card with another one.
12	BUSY LED	Lit while the BUSY signal is output.
13	GATE LED	Lit while the GATE signal is output.
14	STORAGE LED	Lit while the storage is being accessed. (The controller must not be reset or turned OFF while this indicator is lit.)
15	Camera link connector	Connected the camera link cable to this connector.
16	Camera power connector	Connect the camera power cable to this connector.  The camera power cable (F500-VSP) must be connected to this connector. Do not use this connector for any other purposes. CHECK
17	I/O connector (control lines, data lines)	Connect the Controller to external devices such as a sync sensor or PLC.
18	Monitor connector (Composite Video Output)	Connected to the monitor.
19	Monitor Connector (S-VIDEO Output)	Connects to a monitor with an S-VIDEO input.
20	Ethernet Connector	Connect an Ethernet cable (10BASE-T/100BASE-TX) to this connector.

# Mounting the Controller

There are two ways to mount the Controller: horizontal mounting, or vertical mounting.

## ■ Dimensions

(Unit: mm)

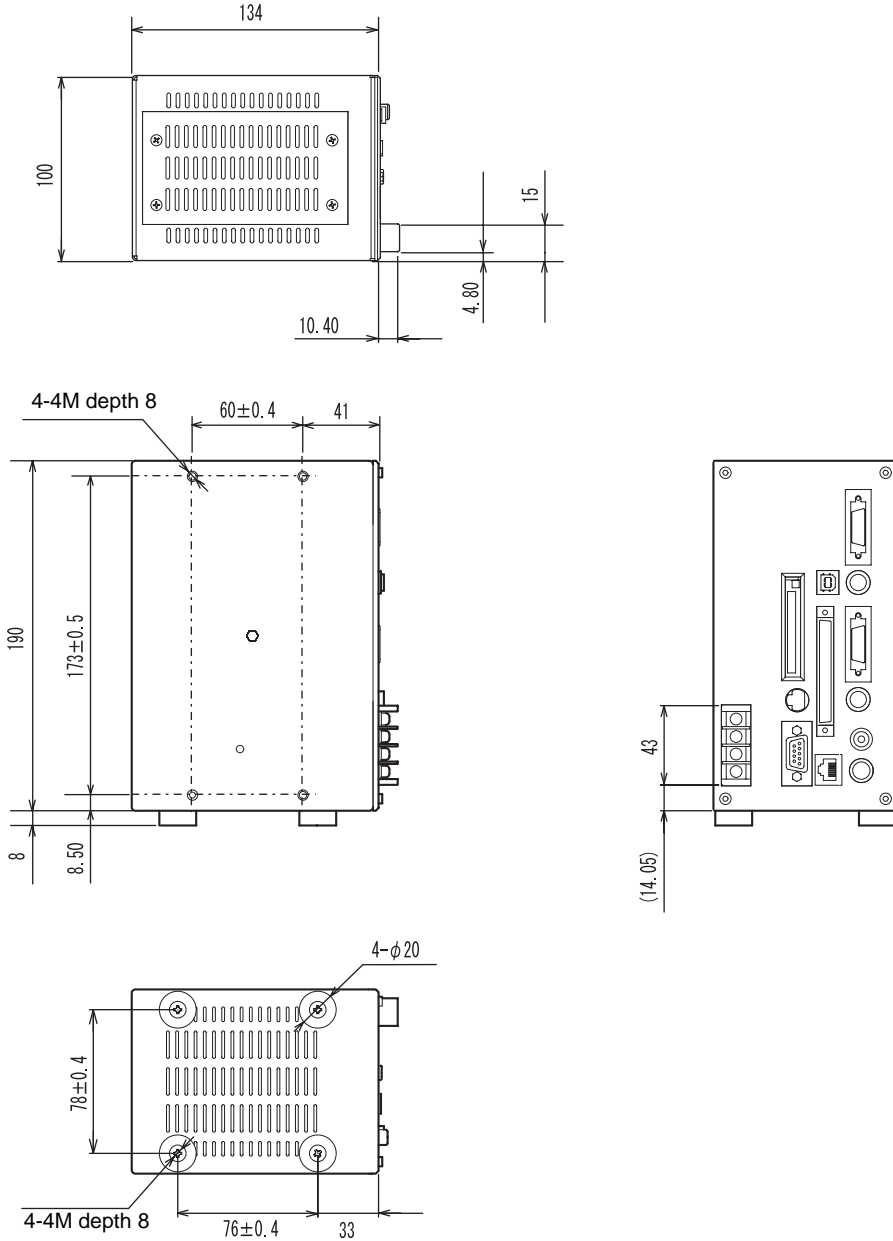

## Horizontal Mounting

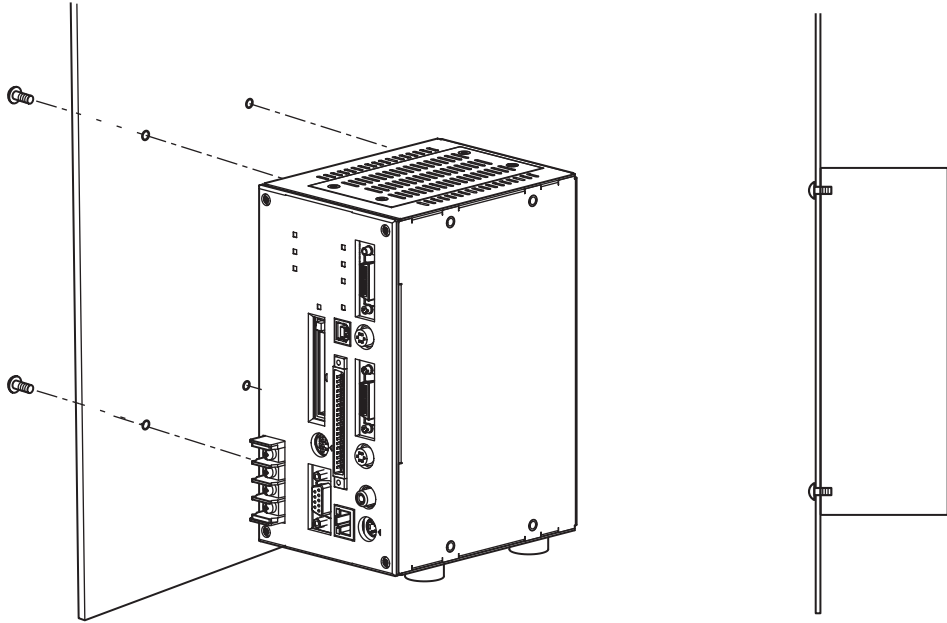

Mounting dimensions

(Unit: mm)

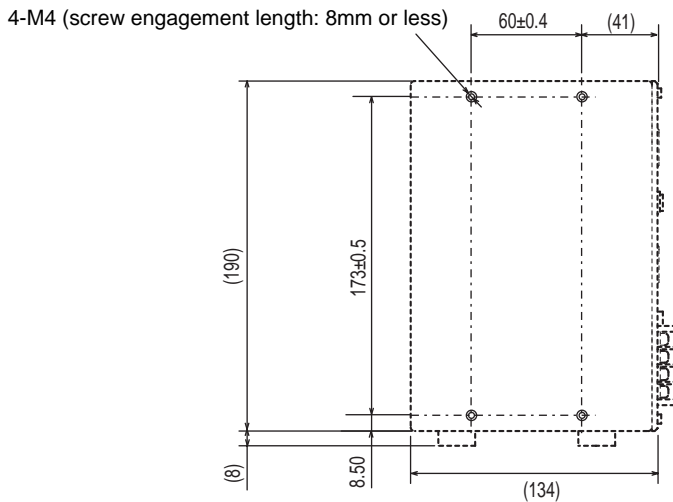

## Vertical Mounting

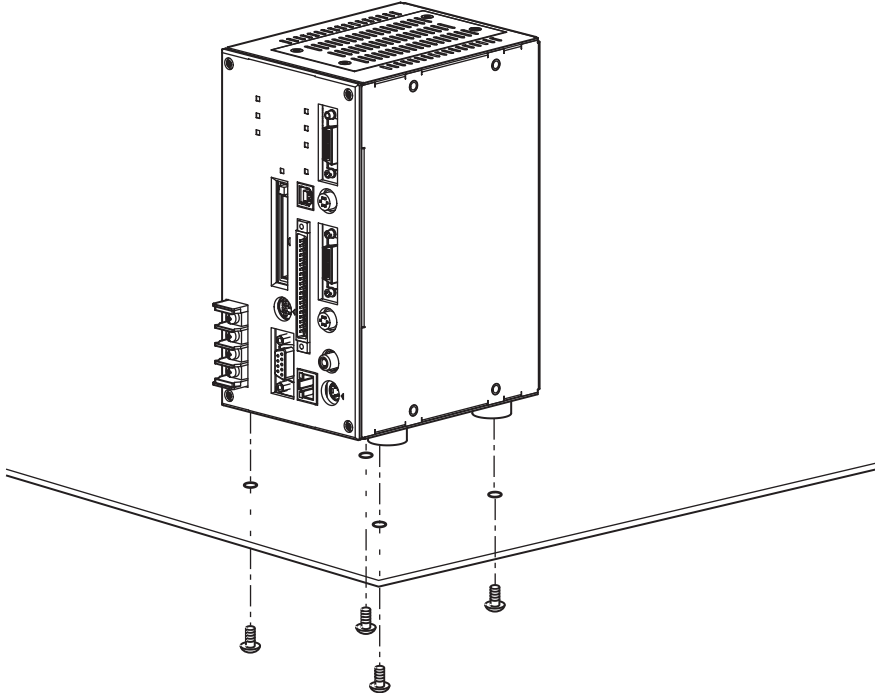

To avoid influences of heat radiation and vibration, make sure that rubber feet are attached to the controller's base when installing it.

CHECK!

### Mounting dimensions

(Unit: mm)

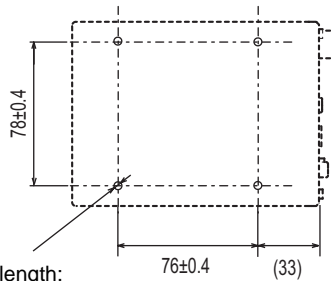

4-M4 (screw engagement length:  
8mm or less)

# Connecting Peripheral Devices

This section shows how to connect peripheral devices to the Controller.



Always turn OFF the controller's power before connecting or disconnecting a peripheral device's cable. The peripheral devices may be damaged if connected or disconnected while the power supply is turned on.



The various connectors on the Controller are capped when the Controller is shipped. When a connector is not being used, leave the cap in place or replace the cap to protect against dust, dirt, and static electricity.

## Connecting a Console

Connect the Console to the Controller's CONSOLE connector. An F160-KP or F150-KP Console can be connected. Install the provided ferrite core onto the cable, positioning the ferrite core about 10mm from the Controller-side connector.

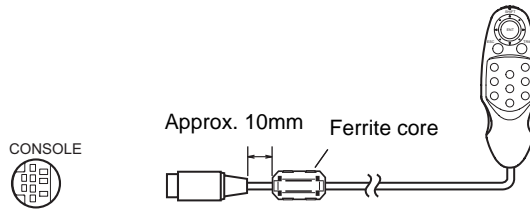

## Connecting a Monitor

Connect the monitor cable to the Controller's MONITOR connector. The S-VIDEO and VIDEO outputs can be used simultaneously.

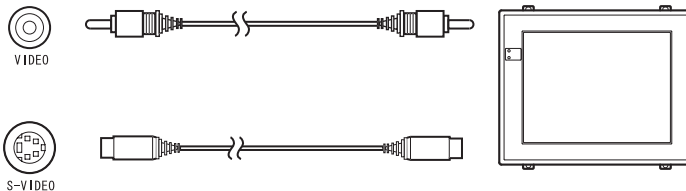

## Connecting a Camera

Connect the camera link cable to the controller's camera link connector and camera power cable to the camera power connector.

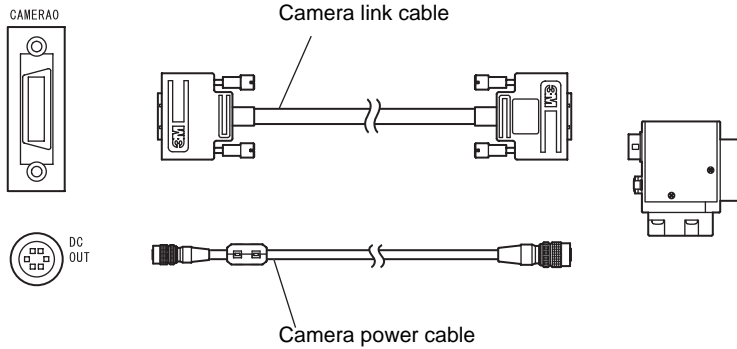

- When connecting the camera link cable, make sure that the screws on both sides of the connector are tightened to secure the connector.
- The camera link cable (F500-VSD2) is polarized, so, make sure that the end bearing a seal is connected to the camera.



# Power Supply and Ground

Wire the power supply and the ground to their respective terminals. Tighten the screws to a torque of 0.49 N-m. After wiring, confirm that the wiring is correct.

## Crimp Terminals and Cables

The terminal block uses M3 terminal screws.  
Use appropriate crimp terminals for M3 screws as shown below.

Recommended Model

	Manufacturer	Model	Recommended
Forked 	J.S.T. Mfg Co., Ltd.	V1.25-N3A	1.31 to 1.65mm
Round 	J.S.T. Mfg Co., Ltd.	V1.25-MS3	

## Ground Wiring

Always connect a ground wire to the Controller's ground terminal. To avoid grounding problems, do not share the ground wire with any other devices or wire the ground to the building's steel framing.

Use a grounding point that is as close as possible and keep the ground wiring as short as possible.

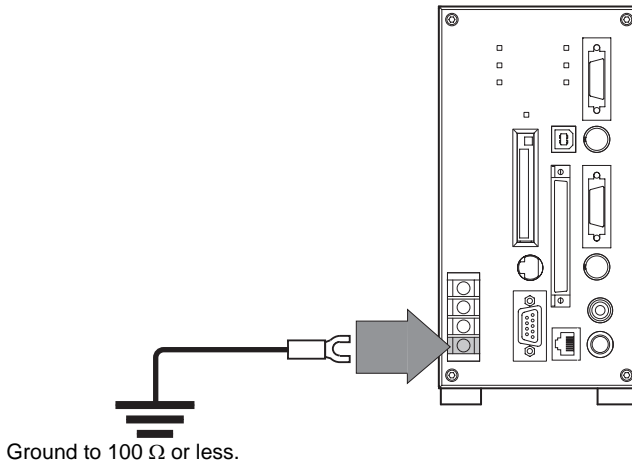



## Wiring the Power Supply

Wire the Power Supply Unit independently of other devices. In particular, keep the power supply wired separately from inductive loads.

Use a power supply that meets the following specifications.

### Condition

Output current	Power supply voltage
2.1A min.	24 VDC +10%, -15%

### Recommended Model

Manufacturer	Model
OMRON Corporation	S82K-05024



Use a DC power supply with safety measures against high-voltage spikes (safety extra low-voltage circuits on the secondary side).

If the system must meet UL standards, use a UL class II power supply.

CHECK!

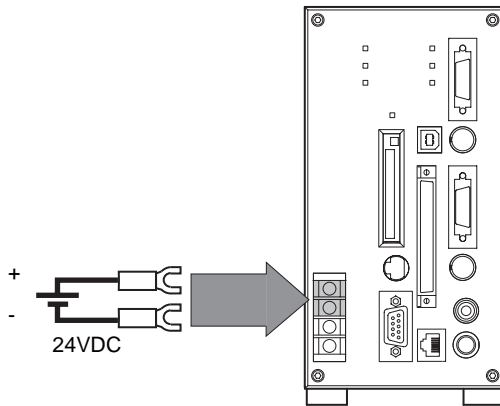



- Keep the power supply line as short as possible (less than 10 m).
- After wiring, replace the protective cover on the power supply terminals.

MEMO

# SECTION 3

## Lenses, Lighting, and Memory Cards

 CCTV Lenses	34
 Lighting	37
 Memory Cards	38

# CCTV Lenses

Refer to the following graph to select the appropriate Lens and Extension Tube. The lens will differ depending on the size of the measurement object and the distance from the Camera.

## Optical Chart

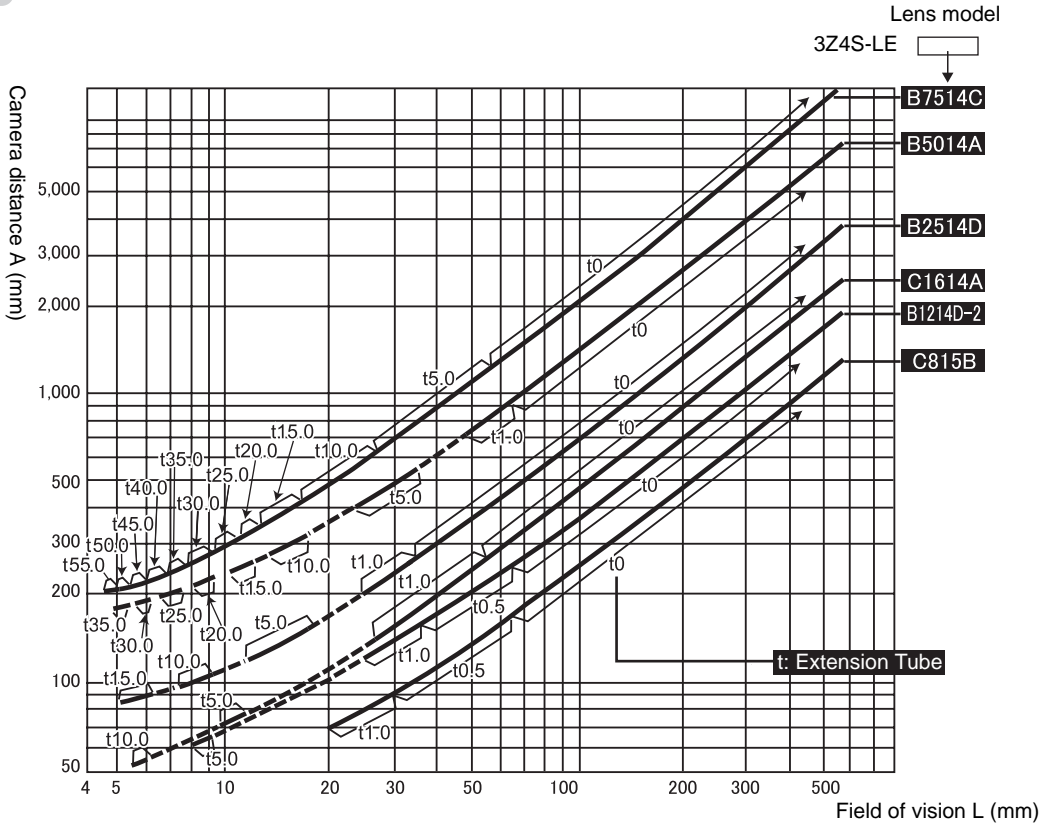

### Understanding the above chart

The X axis of the graph shows field of vision L (mm), and the Y axis shows the camera distance A (mm). The curves on the graph show the relationship between the field of vision and camera distance for each CCTV lens. The values are significantly different for each lens, so double-check the model of the lens before using the graph. The “t” values indicate the lengths of the Extension Tubes. The value “t0” shows the case where an Extension Tube is not needed and the value “t5.0” shows the case where a 5-mm Extension Tube is used.

Example:

When a field of vision of 70mm is required at the measurement point and a 3Z4S-LEB2514DCCTV lens is being used, a camera distance of 500mm and 1-mm extension tube are required.

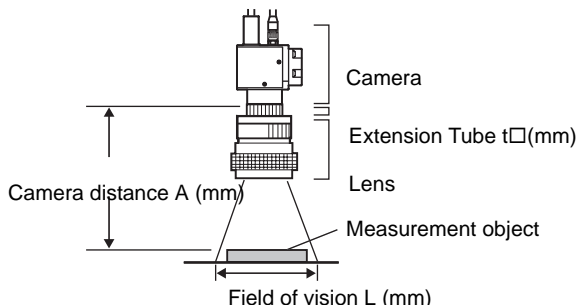

## Lenses and Lens Diameters

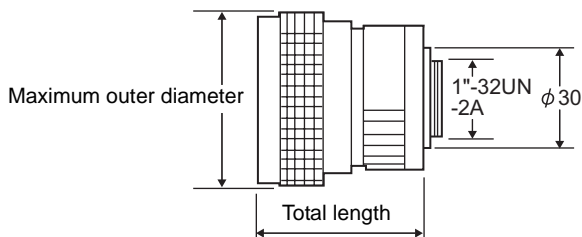

Type of lens and dimensions

Lens model	Focal length	Brightness	Maximum outer diameter	Total length	Filter size
3Z4S-LE C418DX	4.8mm	F1.8	$\phi 40.5\text{mm}$	35.5mm	—
3Z4S-LE B618CX-2	6.5mm	F1.8	$\phi 48\text{mm}$	42mm	
3Z4S-LE EX-C815B	8.5mm	F1.5	$\phi 42\text{mm}$	40mm	M40.5 × P0.5
3Z4S-LE B1214D-2	12.5mm	F1.4	$\phi 42\text{mm}$	50mm	M27 × P0.5
3Z4S-LE C1614A	16.0mm	F1.4	$\phi 30\text{mm}$	33mm	
3Z4S-LE B2514D	25.0mm	F1.4	$\phi 30\text{mm}$	37.3mm	M46 × P0.75
3Z4S-LE B5014A	50.0mm	F1.4	$\phi 48\text{mm}$	48mm	
3Z4S-LE B7514C	75.0mm	F1.4	$\phi 62\text{mm}$	79mm	M58 × P0.75

## Extension Tube

One or more Extension Tubes can be inserted between the lens and the Camera to focus the Camera image. Use a combination of one or more of the six tubes to achieve the required length.

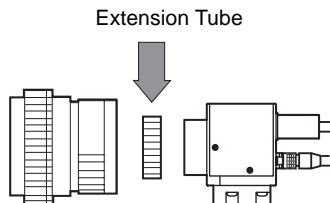

Extension Tube

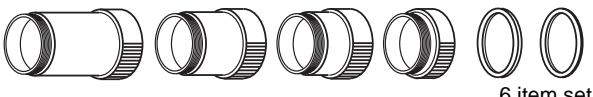
Model	Maximum outer diameter	Length
3Z4S-LE EX-C6	φ31	Length: 40 mm   20mm   10mm   5mm   1.0mm   0.5mm  6 item set



- Do not use the 0.5-mm and 1.0-mm Extension Tubes attached to each other. Since these Extension Tubes are placed over the threaded section of the Lens or other Extension Tube, the connection may loosen when more than one 0.5-mm or 1.0-mm Extension Tube are used together.
- Reinforcement may be required for combinations of Extension Tubes exceeding 30 mm if the Camera is subject to vibration.

# Lighting

A stable image must be obtained to ensure accurate inspection.  
Use appropriate lighting for the application and the measurement object.

## Lighting Methods

### Back Lighting

A stable, high-contrast image can be obtained using back lighting.

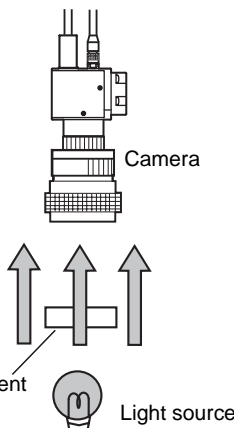

The diagram shows a camera positioned above a measurement object. A light source, represented by a lightbulb, is positioned below the measurement object, with three upward-pointing arrows indicating the direction of light. Labels include 'Camera', 'Measurement object', and 'Light source'.

Applications: Inspection of exterior shape or positioning inspection

### Reflected Lighting

#### Ring Lights

Light is shone uniformly on the measurement object.

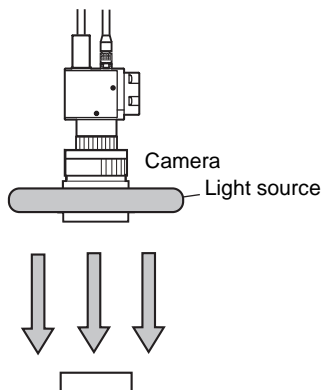

The diagram shows a camera positioned above a measurement object. A light source, represented by a ring light, is positioned between the camera and the measurement object, with three downward-pointing arrows indicating the direction of light. Labels include 'Camera', 'Light source', and 'Measurement object'.

Applications: Surface inspections

### Oblique Lighting

Detection can be made utilizing the difference in regular and diffuse reflected light.

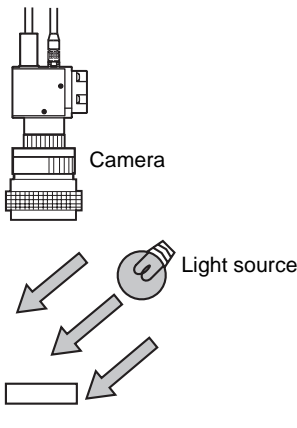

The diagram shows a camera positioned above a measurement object. A light source is positioned to the side, with arrows indicating light reflecting off the measurement object at an angle. Labels include 'Camera', 'Light source', and 'Measurement object'.

Applications: Inspections for surface gloss

### Coaxial Lighting

A stable image can be obtained with few shadows from uneven surfaces on the measurement object.

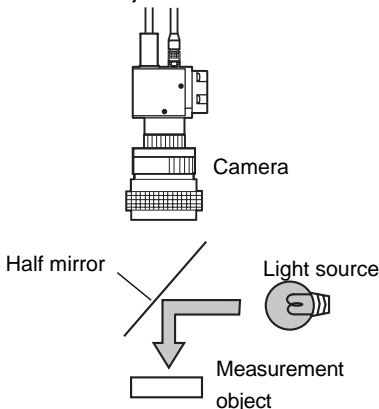

The diagram shows a camera positioned above a measurement object. A light source is positioned to the side, and a half mirror is placed between the light source and the measurement object, reflecting light down onto the object. Labels include 'Camera', 'Half mirror', 'Light source', and 'Measurement object'.

Applications: Surface inspections, positioning, and hole inspections of comparatively small objects

# Memory Cards

Use a Memory Card to back up data such as settings and image data or increase the number of scenes when you are using the Scene Group function. Data from the Controller can be backed up in the computer just by inserting the Memory Card into the computer and copying the desired data. The following procedures also apply to the Memory Card containing the Application Software.

## Recommended Model

Manufacturer	Model	Capacity
OMRON Corporation	F160-N64S(S) <sup>(*)</sup>	64 MB
OMRON Corporation	QM300-N128S	128 MB
OMRON Corporation	F160-N 256S	256 MB

<sup>(\*)</sup> The memory card used for data backup should not be used as the storage memory card. The data cannot be read by a personal computer since it is stored in certain format.



CHECK!

A filler card with no memory is inserted into the Controller's Memory Card slot before the Controller is shipped. Remove this filler card and install a Memory Card to use the Memory Card functions. If Memory Cards are not being used, leave the filler card in place to prevent dust or dirt from entering the Memory Card slot.

## Installing a Memory Card

1. Insert the Memory Card into the Memory Card slot.

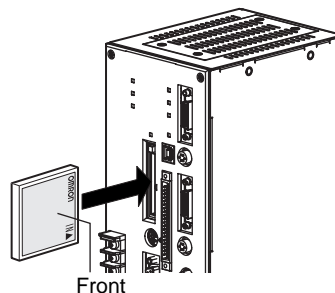

## Removing the Memory Card

1. Turn OFF the power supply to the Memory Card or turn OFF the Controller.



Chapter 4 Additional Functions in the Operation Manual



- Verify that the Memory Card indicator is not lit.



Do not remove the Memory Card if the Memory Card indicator is lit. Doing so may damage the Controller.

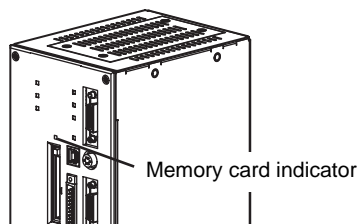

- Press the eject button to the right of the Memory Card slot.  
The Memory Card eject button will pop out slightly.

- Press the memory card eject button.  
The Memory Card will pop out slightly.



Do not remove the Memory Card without pressing the eject button. Doing so may damage the Memory Card or Controller.

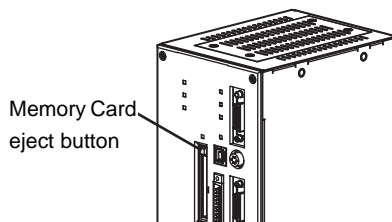

- Pull the Memory Card straight out from the slot.

## Using Memory Cards in a Personal Computer

The Memory Cards can be used in a personal computer with a PC Card drive (PCMCIA 2.0 or higher, type II compatible) or CompactFlash™ drive.

The Memory Card must be inserted into a PC Card Adapter in order to be used in a PC Card drive.

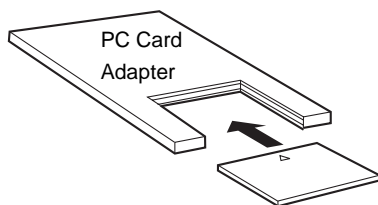



### Recommended Model

Name	Manufacturer	Model
PC Card Adapter	OMRON Corporation	HMC-AP001

MEMO

# SECTION 4

## Connecting External Devices

 Parallel Connection Methods	42
 Connecting through the Serial Interface	47
RS-232C/RS-422 Connections	47
USB Connections	51
 Connecting to Vision Composer Net (Via Ethernet)	53

# Parallel Connection Methods

The Controller's parallel interface (parallel I/O connector) can be used to input signals such as measurement triggers or output signals such as measurement results. The connection method is explained here.

When you want to use the parallel interface to input commands and output measurement results, prepare a parallel I/O cable and connect it to the parallel connector.



For details on communications settings and I/O formats:  
Operation Manual, SECTION 6 Communicating with External Devices

## Connection

Use an F160-VP Parallel I/O Cable (sold separately) to connect the Controller to external devices.

Turn OFF the power supply before connecting or disconnecting a Parallel I/O Cable. Peripheral devices may be damaged if the cable is connected or disconnected with the power ON.

Align the connector with the socket and press it straight into place, then fix it with the screws on both sides of the connector.

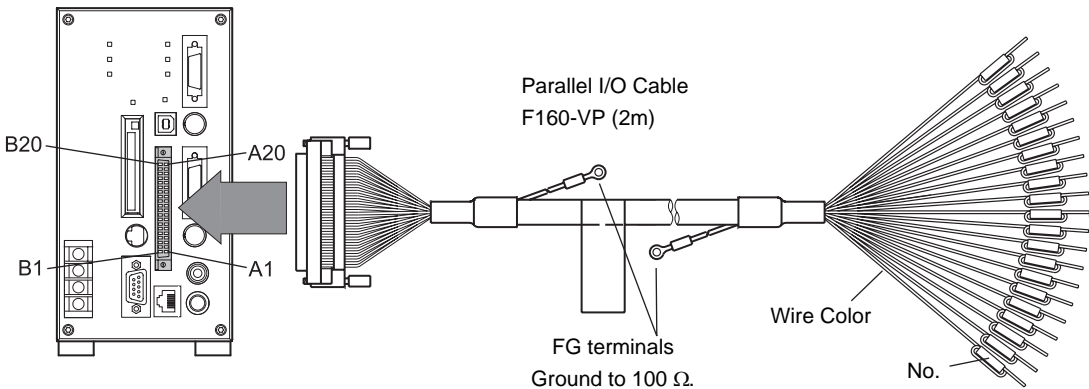

CHECK!

The parallel connectors are capped with screw-on covers when the Controller is shipped. When the connector is not being used, leave the cover in place or replace the cover to protect against dust, dirt, and static electricity.

## I/O Connectors

Each wire of the F160-VP Parallel I/O Cable has a unique wire-color/mark combination.

No.	Signal	Wire Color	Mark (Black)	Function	No.	Signal	Wire Color	Mark (Red)	Function
A1	RESET	Lt. brown	■	Restarts the Controller	B1	COMIN	Lt. brown	■	Common for input signals
A2	STEP	Yellow	■	Measurement trigger signal input	B2	DSA	Yellow	■	Inputs data send request signals
A3	DI0	Green	■	Command inputs	B3	DI1	Green	■	Command inputs
A4	DI2	Gray	■		B4	DI3	Gray	■	
A5	DI4	White	■		B5	DI5	White	■	
A6	DI6	Lt. brown	■ ■		B6	DI7	Lt. brown	■ ■	
A7	DI8	Yellow	■ ■	Command input	B7	DI9	Yellow	■ ■	Command input
A8	STGOUT0	Green	■ ■	Strobe trigger 0 output (See note 1.)	B8	STGOUT1	Green	■ ■	Strobe trigger 1 output (See note 1.)
A9	RUN	Gray	■ ■	ON while in Run mode	B9	ERROR	Gray	■ ■	ON when there is an error.
A10	BUSY	White	■ ■	ON during processing	B10	GATE	White	■ ■	ON for the set output time
A11	OR	Lt. brown	■ ■ ■	Overall judgment result	B11	COMOUT1	Lt. brown	■ ■ ■	Common for output signals (See note 2.)
A12	DO0	Yellow	■ ■ ■	Data output	B12	DO1	Yellow	■ ■ ■	Data output
A13	DO2	Green	■ ■ ■		B13	DO3	Green	■ ■ ■	
A14	DO4	Gray	■ ■ ■		B14	DO5	Gray	■ ■ ■	
A15	DO6	White	■ ■ ■		B15	DO7	White	■ ■ ■	
A16	DO8	Lt. brown	■ ■ ■ ■		B16	COMOUT2	Lt. brown	■ ■ ■ ■	Common for DO0 to DO7
A17	DO9	Yellow	■ ■ ■ ■		B17	DO10	Yellow	■ ■ ■ ■	Data output
A18	DO11	Green	■ ■ ■ ■		B18	DO12	Green	■ ■ ■ ■	
A19	DO13	Gray	■ ■ ■ ■	B19	DO14	Gray	■ ■ ■ ■		
A20	DO15	White	■ ■ ■ ■		B20	COMOUT3	White	■ ■ ■ ■	Common for DO8 to DO15

\*1: This is a signal that is used when the strobe device is connected to the Controller.  
Each Camera has its own strobe trigger output as shown in the following table.

Strobe trigger output	signal
Camera 0	STGOUT0(A8)
Camera 1	STGOUT1(B8)



Connecting a Strobe Device p.45

\*2 A8 to A11 and B8 to B10 are used for control signals.



When using the RESET input to synchronize startup timing, wait at least 1 second after the Controller's power supply is turned ON before turning ON the RESET signal.



Use a DC power supply with countermeasures against high voltages (safe extra low-voltage circuits on the secondary side) for the COMIN and COMOUT terminals. If the system must meet UL standards, use a UL class II power supply.

■ **Making a Parallel I/O Cable**

A parallel I/O cable can be assembled using the following connector and cover or equivalent components. The maximum cable length is 30m.

	Manufacturer	Model
Connector	Fujitsu	FCN-361J040-AU
Cover	Fujitsu	FCN-360C040-B



Double-check the connector wiring for mistakes before turning ON the power supply for the first time.

**Internal Specifications**

**Input Specifications**

Item	Specification	
Model	F210-C10-ETN (NPN mode)	F210-C15-ETN (PNP mode)
Input voltage	6mA typ. (DC12V)/13mA typ. (DC24V)	
ON current *1	5mA max.	
ON voltage *1	8.8V max.	
OFF current *2	2mA max.	
OFF voltage *2	4.5V max.	
ON delay	RESET input: 10ms max. Other inputs: 0.5ms max.	
OFF delay	RESET input: 15ms max. Other inputs: 0.7ms max.	
Internal circuits		

**Output Specifications**

Item	Specification	
Model	F210-C10-ETN (NPN mode)	F210-C15-ETN (PNP mode)
Output voltage	12 to 24 VDC $\pm$ 10%	
Load current	45mA max.	
ON residual voltage	2V max.	
OFF leakage current	0.1mA max.	
Internal circuits		



Do not exceed the maximum load current specified for the Controller.

\*1: ON Current/ON Voltage

This refers to the current or voltage values needed to shift from the OFF/ON state.  
The ON voltage value is the potential difference between each of the input terminals and COM IN.

\*2: OFF Current/OFF Voltage

This refers to the current or voltage values needed to shift from the ON/OFF state.  
The OFF voltage value is the potential difference between each of the input terminals and COM IN.

## ■ Connecting a Strobe Device

Use the camera's corresponding strobe trigger output signal (STGOUT0, STGOUT1) to control the strobe flash timing.

 p.43

The controller's strobe trigger output uses an open-collector circuit and is insulated with a photo-coupler. Thus, a strobe device that is insulated with a photo-coupler or that has a transistor input circuit (negative) must be used.

### • Strobe Related Settings

Set the strobe and shutter triggers according to the strobe device's specifications.

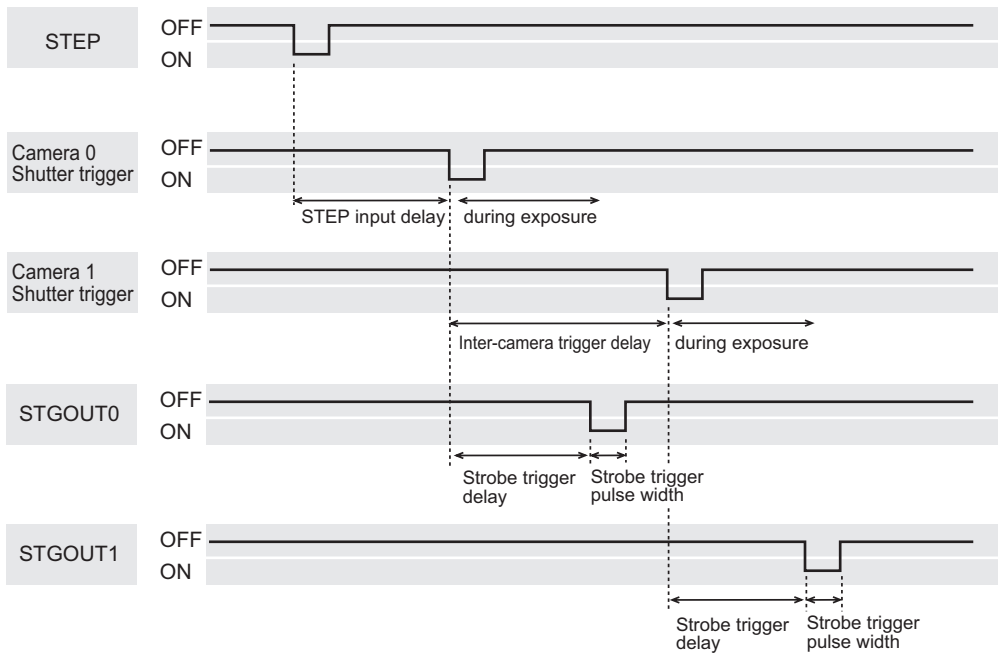

Strobe settings can be made from menus. For details of the setting method, refer to the operation manual.

The screen displayed varies with the setting items.

● Strobe Trigger Related settings

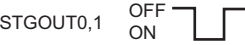
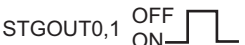

Operation Manual, SECTION 5 System Settings

Item	Setting range	Meaning
Strobe trigger delay	0 to 63 (1*) (1=30μs)	If an F210-S1 camera is used, the default strobe trigger delay (i.e. 1) must be left unchanged. The time to be elapsed before the strobe trigger pulse is output after the camera trigger pulse (shutter trigger) is output must be set. Make sure that the strobe flashes during exposure.
Strobe trigger pulse width	1 to 63 (3*) (1=30μs)	Set the width of the strobe trigger pulse (w). Set it according to the strobe device's specifications.  
Strobe trigger pulse polarity	Positive *	The flash is synchronized to the OFF-to-ON transition of the strobe trigger signal.  
	Negative	The flash is synchronized to the ON-to-OFF transition of the strobe trigger signal.  

The asterisk (\*) indicates the default setting.

● Shutter Trigger Related settings



Operation Manual, SECTION 2 Input image

Item	Setting range	Meaning
STEP input delay	0 to 511 (0*) (1=30μs)	Set this item when you want to adjust the work's image pickup position. The time to be elapsed before the camera trigger pulse (shutter trigger) is output after the STEP signal is input must be set.
Inter-camera trigger delay	0 to 63 (0*) (1=30μs)	Set this item when two cameras are connected and you want to prevent mutual interference of light emission. The interval between the trigger pulse for camera 0 and that for camera 1 must be set.

The asterisk (\*) indicates the default setting.



# Connecting through the Serial Interface

The Controller's serial interface (RS-232C/RS-422 connector) can be used to input signals such as measurement triggers or output signals such as measurement results. Additionally, data that has been set in the Controller can be backed up in a personal computer. This section explains how to connect the terminal blocks to the Controller.



For details on communications settings and I/O formats:  
Operation Manual, SECTION 6 Communicating with External Devices

## RS-232C/RS-422 Connections

### ■ Connection Examples

- 1:1 Connection (Normal, Menu Operation)

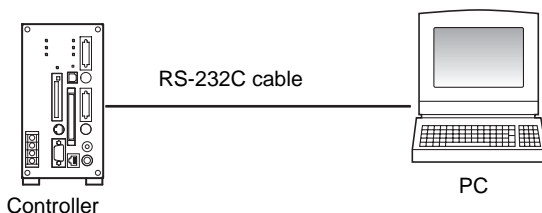

- Multi-drop Connection (Normal)

Communications between one computer and several Controllers (at most 31 Controllers) is possible using Link Adapters.

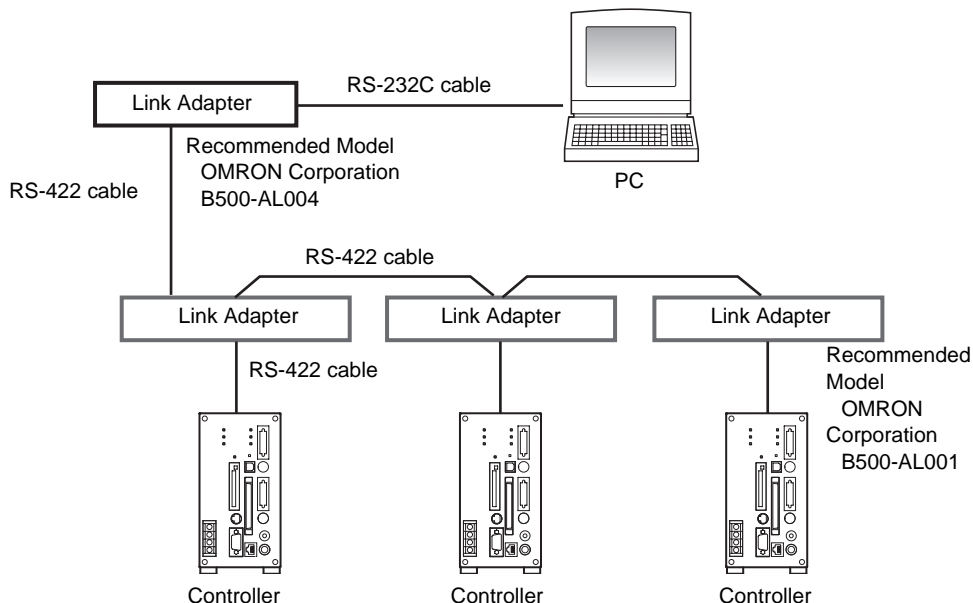

## SECTION 4 Connecting External Devices



When B500-AL004 Link Adapters are being used, termination must be set to ON in the last node in the line and the node must be terminated as follows:

- Connect  $220\Omega$  (1/2 W min.) between RDA (-) and RDB (+).
- Connect  $220\Omega$  (1/2 W min.) between SDA (-) and SDB (+).

### • 1:1 Connection (Host Link)

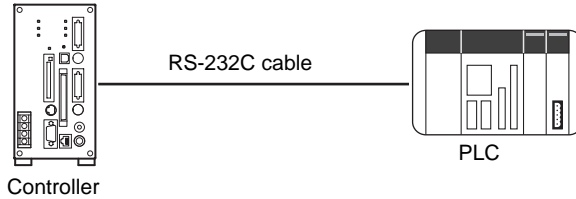

### ■ Connector

The Controller's RS-232C/RS-422 Connector is a 9-pin D-SUB female connector. The pins are arranged as follows.

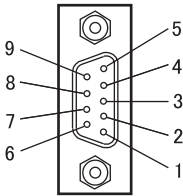

Pin No.	Signal name	Function
1	FG	Protective frame ground
2	SD	For RS-232C
3	RD	For RS-232C
4	NC	Not connected
5	RDB(+)	For RS-422
6	RDA(-)	For RS-422
7	SDB(+)	For RS-422
8	SDA(-)	For RS-422
9	GND	Signal ground

Use a compatible connector.

#### Recommended Model

	Manufacturer	Model
Plug	OMRON Corporation	XM2A-0901
Hood	OMRON Corporation	XM2S-0911

■ Wiring

The maximum cable length is 15m.

• RS-232C

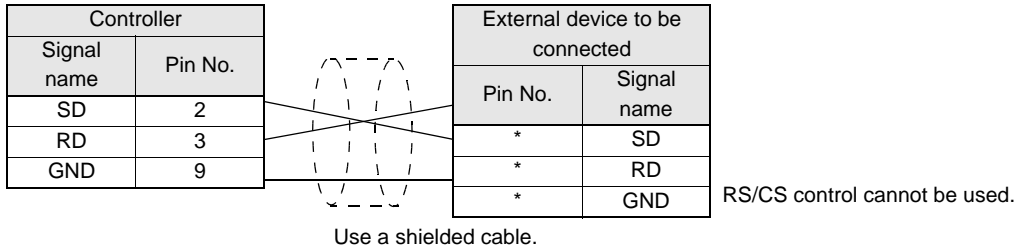

• RS-422

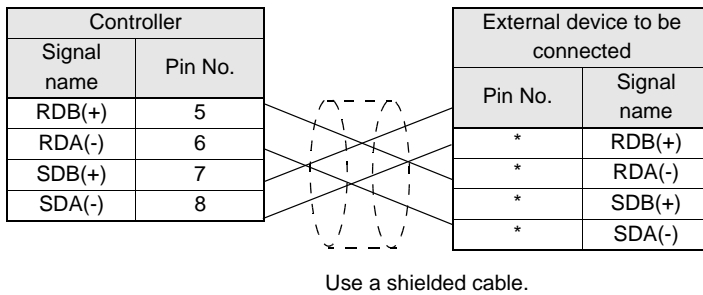

\* Pin numbers on the external device will depend on the device being connected. Refer to the manual for the personal computer or PLC being connected.

■ **Connection Methods**

Turn OFF the power supply before connecting or disconnecting an RS-232C/RS-422 cable. Peripheral devices may be damaged if the cable is connected or disconnected with the power ON.

Align the connector with the socket and press it straight into place, then fix it with the screws on both sides of the connector.

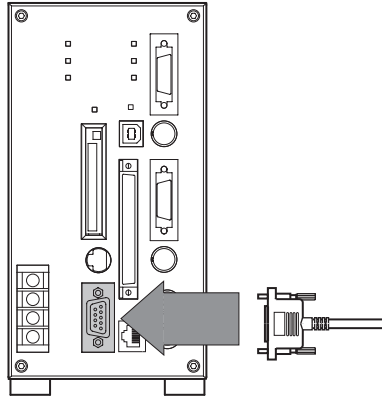

The various connectors on the Controller are capped when the Controller is shipped. When a connector is not being used, leave the cover in place or replace the cover to protect against dust, dirt, and static electricity.

## USB Connections

The personal computer must be connected to a controller(s) using a USB cable (series A, series B) that supports FS (Full Speed) mode.

When connecting the personal computer to a controller(s) for the first time, the USB driver must be installed in the personal computer first.

The USB driver is supplied with the Application Software for Vision Mate Series (CD-ROM).

Install the USB driver according to the driver installation manual provided for the OS.

### ■ Connection Examples

- 1:1 Connection

The maximum cable length is 5m.

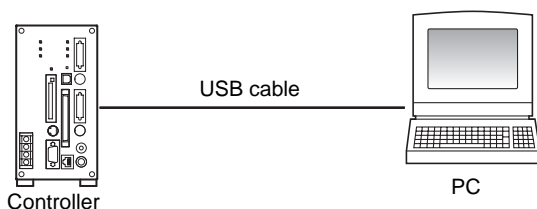

- 1:N Connection

Communications between one computer and several Controllers (at most 127 Controllers) is possible using HUB.

Up to five HUBs can be daisy-chained. Make sure that each HUB cable (connecting a HUB to another) is 5m or shorter.

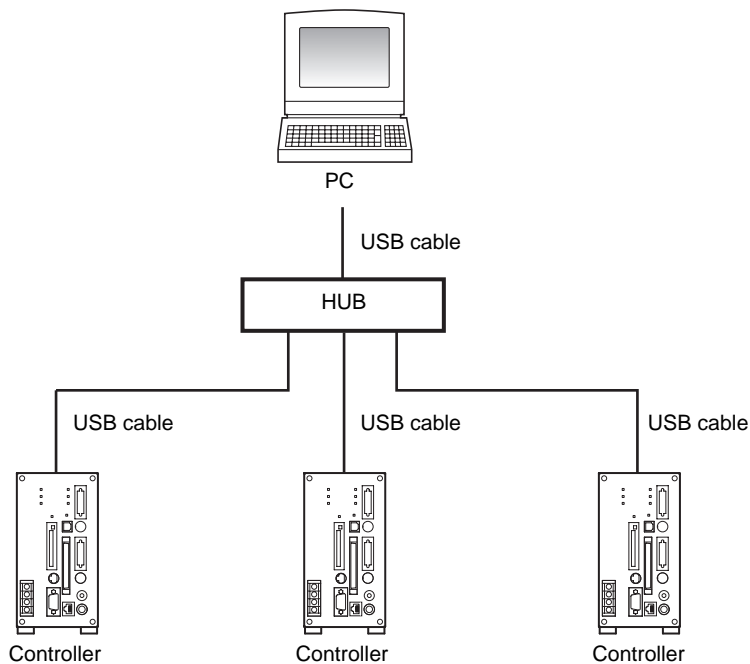

■ **Connection Methods**

Connect the series-A side of the cable to the personal computer, and the series-B side to the controller.

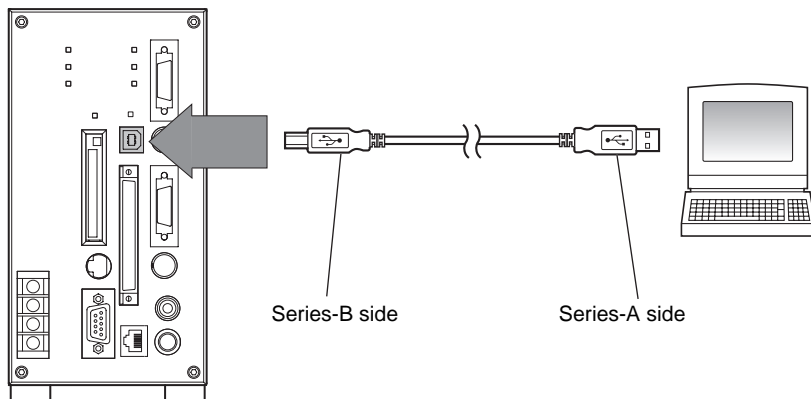

The various connectors on the Controller are capped when the Controller is shipped. When a connector is not being used, leave the cover in place or replace the cover to protect against dust, dirt, and static electricity.



For the driver installation method, refer to the "readme.txt" file provided with the application software.

# Connecting to Vision Composer Net (Via Ethernet)

Setting, operation and monitoring of the controller can be performed via network. This section explains how to connect the terminal blocks to the Controller.



Setting the Controller's IP Address and Subnet Mask.  
Operation Manual, SECTION 5 System Settings

## ■ Connection Examples

### • 1:1 Connection

Connect the personal computer and controller with a 10BASE-T/100BASE-TX cross cable (category 5 or higher). The cable length must be less than 30m.

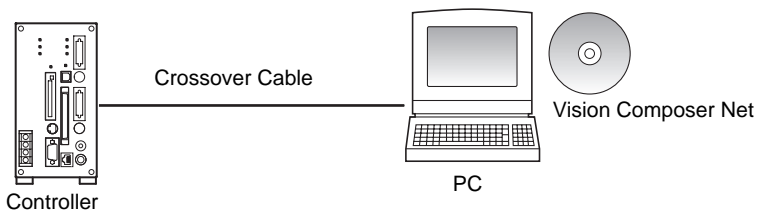

### • HUB connections

Connect the personal computer and controller with a 10BASE-T/100BASE-TX straight cable (category 5 or higher). The cable length between the Controllers and the Hub must be less than 30m.

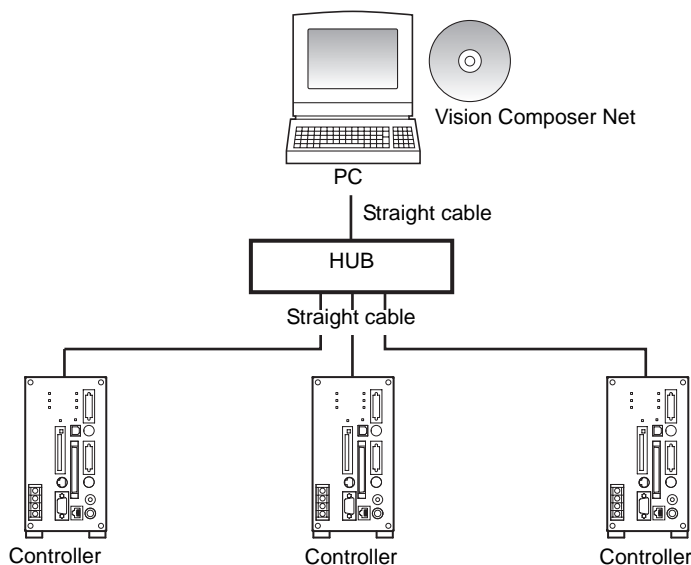

The following operating methods are also possible.

- One controller can be monitored by two or more personal computers.
- Controllers located at a distance (e.g. at factory) can be monitored/operated from a router in the office.

For details of connecting method, refer to the manual of the network devices to be used.



It is not possible to connect controllers through firewall.

CHECK!

### ■ Connection Methods

Turn OFF the power supply before connecting or disconnecting an Ethernet connection cable. Peripheral devices may be damaged if the cable is connected or disconnected with the power ON. Align the connector with the socket and press the connector straight into the place.

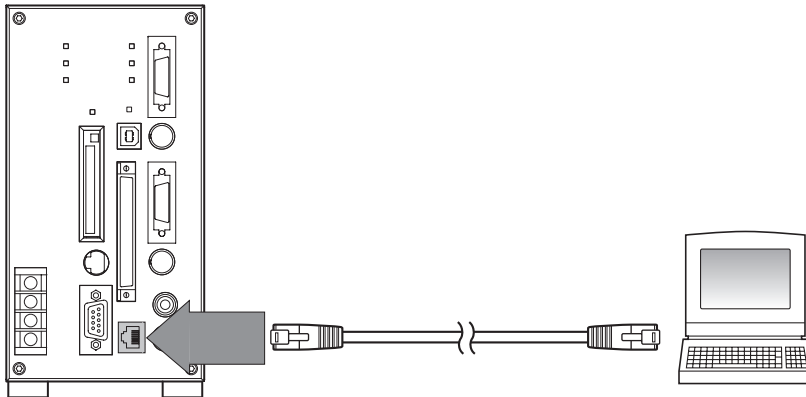





The various connectors on the Controller are capped when the Controller is shipped. When a connector is not being used, leave the cover in place or replace the cover to protect against dust, dirt, and static electricity.

CHECK!



# SECTION 5

## Troubleshooting and Maintenance

 Troubleshooting	56
 Q&A	60
 Maintenance	61
 Specifications	63

# Troubleshooting

This section lists probable corrections for common hardware problems. Please check all of the following items before requesting repairs.

For problems regarding connection with Vision Composer Net, refer to “Troubleshooting” in the Vision Composer Net manual.

## Connection Errors

Problem	Probable cause	Reference
The Power indicator does not light up.	<ul style="list-style-type: none"> <li>● The power supply is not connected properly.</li> <li>● The supply voltage is not 24 VDC +10%/-15%.</li> </ul>	p.31
The video monitor is blank.	<ul style="list-style-type: none"> <li>● The power to the Video Monitor is not ON.</li> <li>● The Monitor Cable is not connected properly.</li> <li>● The video monitor is malfunctioning.</li> <li>● (In the case of a liquid crystal display monitor) The capacity of the power supply is insufficient.</li> </ul>	p.28
The video monitor image is not clear.	<ul style="list-style-type: none"> <li>● There is electrical noise entering from the power supply or cables.</li> <li>● The Monitor Cable is not connected properly.</li> </ul>	–
Cannot make key inputs from the console.	<ul style="list-style-type: none"> <li>● The console cable is not connected correctly.</li> </ul>	p.28
Camera images do not appear on the screen	<ul style="list-style-type: none"> <li>● The lens cap has not been removed.</li> <li>● The Camera Cable is not correctly connected.</li> <li>● The lens iris is opened or closed too far.</li> <li>● The shutter speed is not suitable.</li> <li>● The lighting method is not suitable.</li> </ul>	p.29  p.37
Excessive noise is present in the camera image.	<ul style="list-style-type: none"> <li>● The camera link cable is not connected correctly.</li> </ul>	p.29

## ? Menu Operation Errors

Problem	Probable cause	Reference
The measurement results are not displayed on the Video Monitor.	<ul style="list-style-type: none"> <li>● The Controller is not in Monitor or Run mode.</li> </ul>	Operation Manual

## ? Parallel Interface Errors

Problem	Probable cause	Reference
Trigger signals (input signals) are not received.	<ul style="list-style-type: none"> <li>● The cables are not correctly wired.</li> <li>● The signal line is disconnected. The status of communications can be checked with the I/O monitor.</li> <li>● The Controller is not in Monitor or Run mode.</li> </ul>	p.42 Operation Manual
Signals cannot be output externally.	<ul style="list-style-type: none"> <li>● The trigger signal has not been input.</li> <li>● The cables are not correctly wired.</li> <li>● The signal line is disconnected. The status of communications can be checked with the I/O monitor.</li> <li>● The Controller is not in the Run mode.</li> </ul>	p.42 Operation Manual

**? Serial Interface (RS-232C/RS-422) Errors**

Problem	Probable cause	Reference
<p>No communication is possible.</p>	<ul style="list-style-type: none"> <li>● The cables are not correctly wired.</li> <li>● The Controller's communications specifications do not match those of the external device.</li> <li>● The communications mode was not selected under [System settings/Communication/Serial].                      Select [Normal], [Host link], or [Menu] in the Communications (Serial) menu.                      The status of communications can be checked with the I/O monitor.</li> <li>● Is a USB cable connected?                      If both cables are connected, priority will be given to USB communication.</li> </ul>	<p>p.47                      Operation Manual</p>
<p>The Unit operates well initially, but after a while there is no response from the Controller.</p>	<ul style="list-style-type: none"> <li>● The reception buffer on the external device (e.g., computer) is full.                      Check that settings allow the data to be properly received.</li> </ul>	<p>–</p>
<p>Cannot perform menu operations from the computer.</p>	<ul style="list-style-type: none"> <li>● The communications mode was not set to [Menu] in the [System settings/Communication/Serial].</li> </ul>	<p>Operation Manual</p>
<p>Data cannot be saved.</p>	<ul style="list-style-type: none"> <li>● The Controller's communications specifications do not match those of the external device.</li> <li>● Is flow control turned OFF under [System settings/Communication/Normal]?</li> </ul>	<p>Operation Manual</p>

## Serial Interface (USB) Errors

Problem	Probable cause	Reference
<p>No communication is possible.</p>	<ul style="list-style-type: none"> <li>● The cables are not correctly wired.</li> <li>● USB Cables are not being used for the 1:N connections. Power is not being supplied to the HUB, the settings are incorrect, or the connections are incorrect.</li>   <li>● Is the correct COM port set for the personal computer communication software?</li> <li>● The communications mode was not selected under [System settings/Communication/Serial]. Select [Normal] or [Menu] in the Communications (Serial) menu. The status of communications can be checked with the I/O monitor.</li> <li>● Communications are being affected by a noise source (such as a power line) that is too close to the Controller or communications cables.</li> <li>● Is serial communication set for the personal computer communication software?</li> </ul>	<p>p.51</p> <p>Operation Manual</p>
<p>The Unit operates well initially, but after a while there is no response from the Controller.</p>	<ul style="list-style-type: none"> <li>● The reception buffer on the external device (e.g., computer) is full. Check that settings allow the data to be properly received.</li> </ul>	<p>—</p>
<p>The response from the Controller is slow. (It takes too long to transfer data and errors occur.)</p>	<ul style="list-style-type: none"> <li>● Communications are being affected by a noise source (such as a power line) that is too close to the Controller or communications cables.</li> <li>● The communications load is too heavy.</li> <li>● The computer's processing load is too heavy. (A program that requires a lot of processing capacity is being run simultaneously.)</li> </ul>	<p>Operation Manual</p>
<p>Cannot perform menu operations from the computer.</p>	<ul style="list-style-type: none"> <li>● The communications mode was not set to [Menu] in the [System settings/Communication/Serial].</li> </ul>	<p>Operation Manual</p>

## Q&A

For items regarding Vision Composer Net, refer to the Vision Composer Net manual.

### Cameras

Questions	Answers
Are the shutter timings synchronized when two or more cameras are connected?	By default, they are synchronized. The timing can be changed from menus.
Can a camera other than F210-S1 be connected?	Only F210-S1 can be connected to F210-C10-ETN,F210-C15-ETN. No other cameras can be connected.
Can F500-S1 be used?	With F210-C10-ETN,F210-C15-ETN, it is not possible to use F500-S1. F210-S1 must be used.

### Cabling Errors

Questions	Answers
Are there any recommended OMRON RS-232C cable available?	One of the following OMRON cables is recommended. Select a cable that works with the device being connected. Connecting to a PC/AT or compatible computer (9-pin connector) <ul style="list-style-type: none"> <li>• XW2Z-200S-V (2m)</li> <li>• XW2Z-500S-V (5m)</li> </ul> Connecting to a SYSMAC device (9-pin connector) <ul style="list-style-type: none"> <li>• XW2Z-200T (2m)</li> <li>• XW2Z-500T (5m)</li> </ul>
Can a commercially available cable be used instead of the F150-VM Monitor Cable?	Yes, as long as it's a pin jack cable (with a yellow connector) for video signal connection.

# Maintenance

## Regular Inspection

To maintain the Controller in the best condition, perform the following regularly.

- Clean the Lens with a lens-cleaning wipe or blow off dust with an aerosol air sprayer.
- Lightly wipe off dirt with a soft cloth.
- Dirt on the CCD must be removed using an air brush.

Inspection point	Details	Tools required
Power supply	The voltage measured at the power supply terminals must be 24 VDC +10%/-15%.	Circuit tester
Ambient temperature	The operating ambient temperature inside the cabinet must be between 0 and 50°C.	Thermometer
Ambient humidity	The operating ambient humidity inside the cabinet must be between 35% and 85%.	Hygrometer
Installation condition	Cables and connectors connected to each device must be correctly inserted and locked. The Cameras must be firmly secured. Mount the Light on the Camera.	Screwdriver



CHECK!

- Turn OFF the power and take safety precautions before conducting inspections. Electrical shock can result from attempting safety inspections with the power turned ON.
- Do not use thinners or benzene to clean the Controller.

## Replacing the Memory Card for data storage

A memory card for storage is delivered with this controller.

The memory card has a life, and it can no longer be accessed after writing to the memory card is performed more than a certain number of times.

If a message "STORAGE ERROR" is displayed on the monitor at startup, replace the memory card with a new one.

Manufacturer	Model
OMRON Corporation	F160-N64S (S)



CHECK!

- Before removing the memory card, turn OFF the power to the controller and let it stand still until it cools down.
- The life of the memory card varies with the operating conditions. If the controller is set to save all images and is operated continuously without a break, the life will be approximately two years.
- Make sure to use the above specified memory card.
- Make sure not to apply the memory card for other purpose, which is used for data storage of F210-C10-ETN, F210-C15-ETN. Due to the difference in data format, the memory card used for data storage cannot be read by the personal computer.

1. Open the storage cover on top of the controller.

Remove the screws using a Philips screwdriver.



CHECK!

Take care not let the screws drop into the controller. If the screws have dropped into the controller, place the controller upside down to remove them. If the screws cannot be removed, contact OMRON.

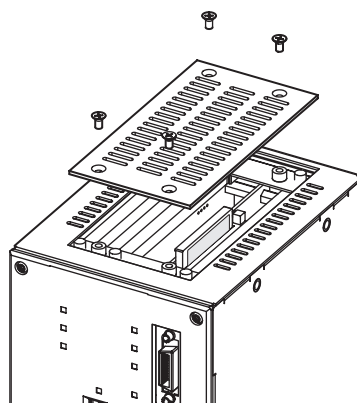

2. Press the Memory Card eject button.

The Memory Card will pop out slightly.

3. Hold the memory card and pull it out.

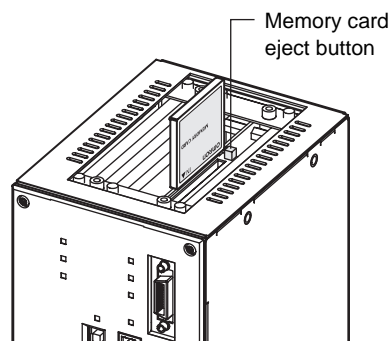

4. Insert a new memory card into the controller in the reverse order of removal.



# Specifications

Controller

F210-C10-ETN/F210-C15-ETN

(Unit: mm)

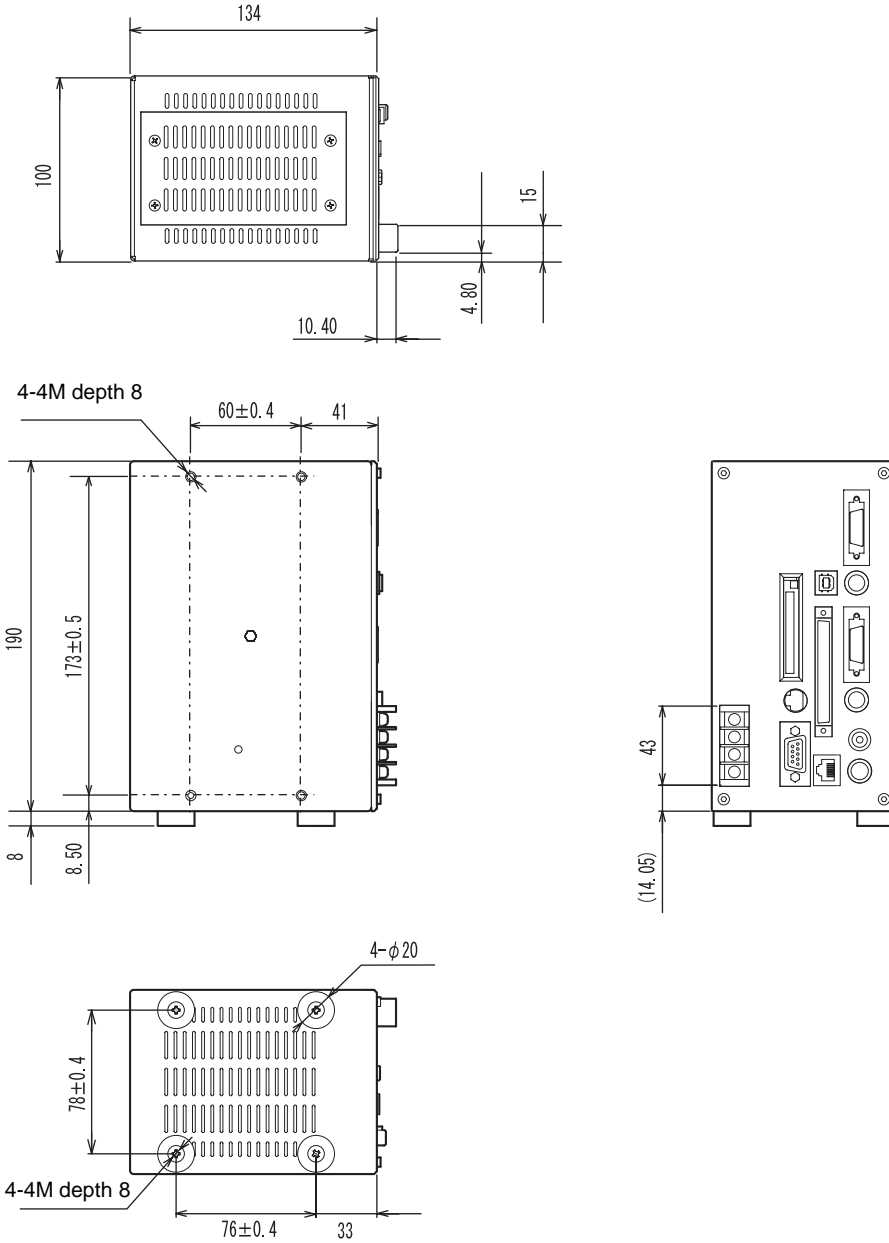

General specifications

Model	F210-C10-ETN	F210-C15-ETN
Input/Output type	NPN	PNP
Power supply voltage	20.4 to 26.4V DC	
Current consumption	Approx. 2.1A max	
Dielectric strength	Between the group of external DC terminals and the ground terminal: 840V AC at 50/60Hz (when the built-in surge absorber is removed)	
Leakage current	10mA max.	
Noise Resistance	2,000V; pulse width: 50ns; rise time: 5ns (pulse) Burst continuation time: 15ms; Period: 300ms	
Vibration resistance	10 to 150Hz at a single-amplitude of 0.1mm (maximum acceleration: 15 m/s <sup>2</sup> ), 10 times for 8 minutes each in 3 directions	
Ambient Temperature	0 to +50°C at operation, -25 to +65°C at storage with no icing nor condensation	
Ambient humidity	Operating and storage: 35% to 85% with no condensation	
Ambient environment	No corrosive gases	
Ground	D-type ground (ground resistance 100Ω or less) * conventional class 3 ground	
Degree of protection	IEC60529 IP20	
Materials	Case material: SECC-T Front panel: PC	
Battery life	Approximately 7 years	
Weight	Approx. 1.6 kg (Controller only)	

Digital camera  
F210-S1

(Unit: mm)

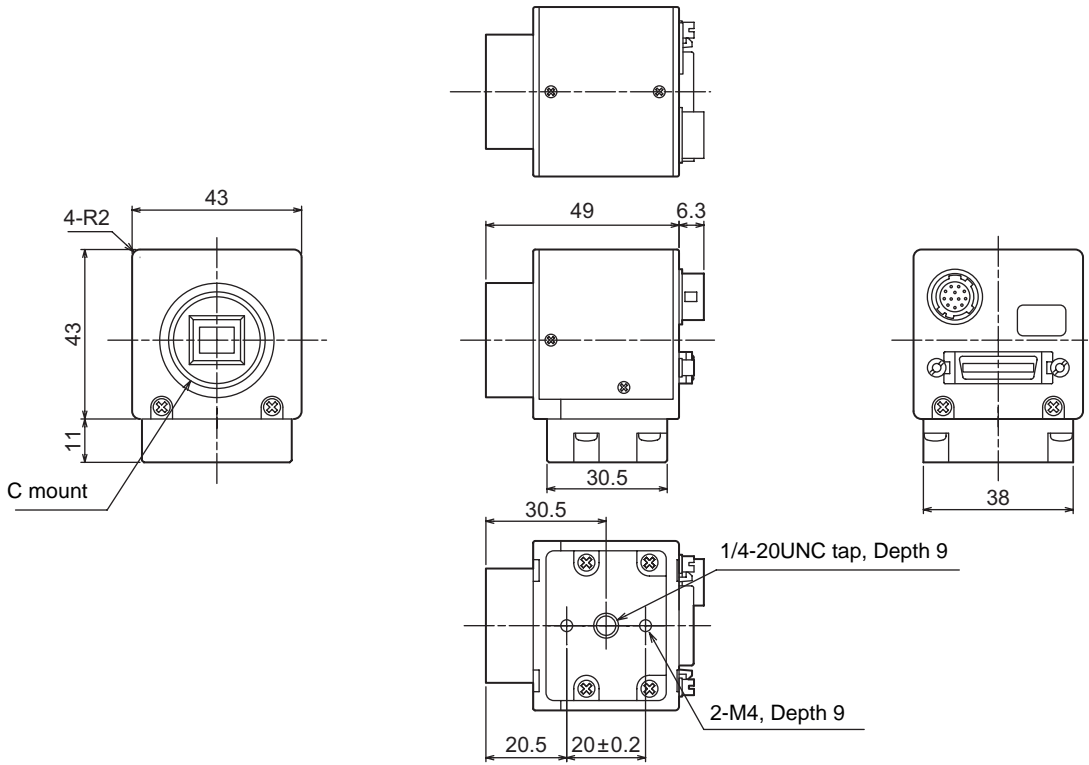

Cameras

General specifications

Power supply voltage	10 to 15VDC
Power consumption	3W max.
Vibration resistance	10 to 150 Hz; half-amplitude: 0.35 mm; maximum acceleration: 50 m/s <sup>2</sup> , 10 times for 8 minutes each in 3 directions.
Shock resistance	Shock resistance 150m/s <sup>2</sup> , 3 times each in 6 directions
Ambient Temperature	Operating: 0 to 50°C (with no icing nor condensation) Storage: -25 to 60°C (with no icing nor condensation)
Ambient humidity	Operating and storage: 35% to 85% (with no condensation)
Ambient environment	No corrosive gases
Materials	Cover: Corrosion resisting aluminum alloy (A5052P-H34) Case: Die-cast (ADC-12) Camera mounting base: Fiber-reinforced plastic (black)
Weight	Approx. 110g

Performance specifications

Picture element	1/3-inch interline monochrome CCD (reading all pixels)
Charge storage mode	Frame storage
Effective pixels	659 (H) x 494 (V)
Pixel size	7.4(μm) x 7.4(μm) (Square pixel)
Scanning method	Non-interlace mode
Vertical frequency	59.940Hz
Horizontal frequency	31.468KHz
Pixel frequency	24.545MHz
Number of lines to be read *1	484, 235, 104, 54, 38, 26, 14 lines
Synchronization	Internal Sync./External Sync.
Video output	Digital (10 bits)
Communication interface	Conforms to Camera Link.
Gain *1	-14dB to +18dB
Shutter speed *1	1/60, 1/100, 1/250, 1/500, 1/1000, 1/2000, 1/4000, 1/12000s
Lens mounting	C mount

\*1: Set/changed by Camera Link.

Console  
F150-KP

(Unit: mm)

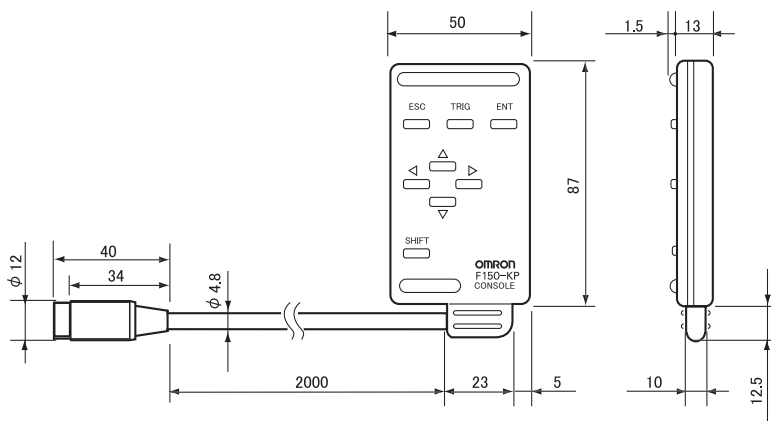

### General specifications

Vibration resistance	10 to 150Hz at a single-amplitude of 0.15mm, 4 times for 8 minutes each in 3 directions
Ambient Temperature	0 to 50°C at operation, -25 to 65°C at storage (with no icing nor condensation)
Ambient humidity	Operating and storage: 35% to 85% (with no condensation)
Ambient environment	No corrosive gases
Degree of protection	IEC60529 IP20 (in-panel)
Minimum bending radius	75mm
Materials	Console: ABS Cable sheathing: Heat-resistant chlorinated vinyl Connector: PC and PBT
Weight	Approx. 135g

## SECTION 5 Troubleshooting and Maintenance

Console  
F160-KP

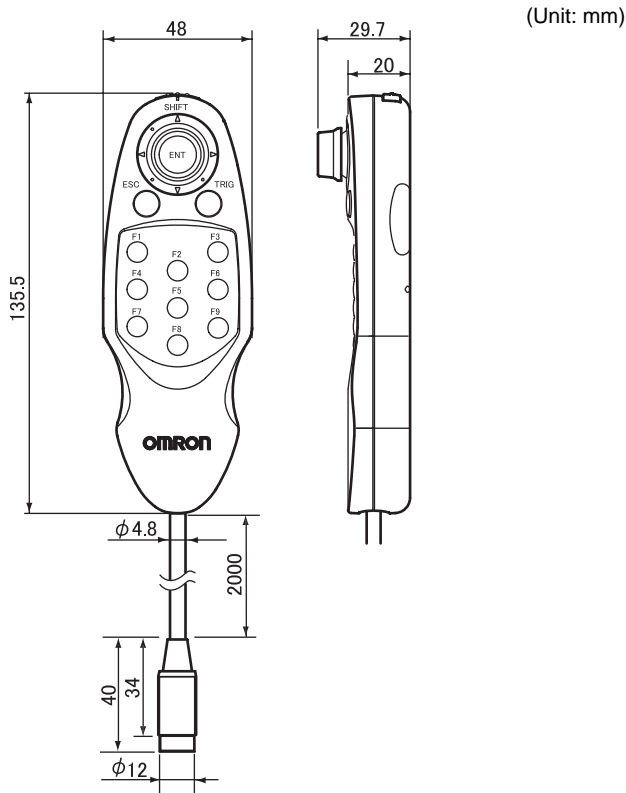

### General specifications

Current consumption	Approx. 10mA
Vibration resistance	10 to 150Hz at a single-amplitude of 0.35mm (maximum acceleration: 50m/s <sup>2</sup> ), 10 times for 8 minutes each in 3 directions
Ambient Temperature	Operating: 0 to 50°C (with no icing nor condensation) Storage: -25 to 65°C (with no icing nor condensation)
Ambient humidity	Operating and storage: 35% to 85% (with no condensation)
Ambient environment	No corrosive gases
Degree of protection	IEC60529 IP20
Minimum bending	75mm
Materials	Console: ABS Cable sheathing: Heat-resistant chlorinated vinyl Connector: PC and PBT
Weight	Approx. 160g



The switch on the back of the F160-KP must be set to "ENABLE"

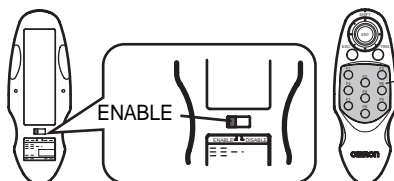

These keys will be disabled if the switch is set to "DISABLE".

Camera link cable (For F500-S□, F210-S□ Cameras)

F500-VSD2

(Unit: mm)

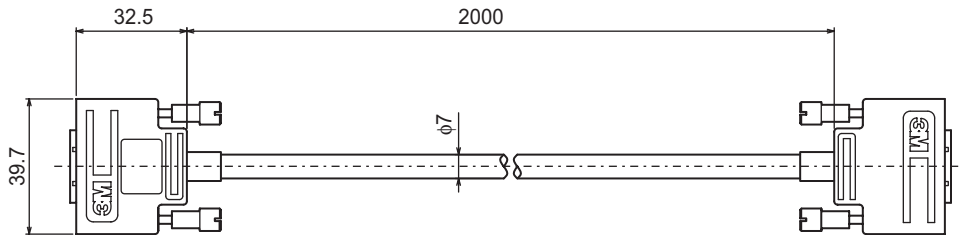

### General specifications

Vibration resistance	10 to 150Hz at a single-amplitude of 0.15mm, 4 times for 8 minutes each in 3 directions
Ambient Temperature	Operating and storage: 0 to 65°C (with no icing nor condensation)
Ambient humidity	Operating and storage: 40% to 70% (with no condensation)
Ambient environment	No corrosive gases
Materials	Cable sheathing: Heat-resistant chlorinated vinyl Connector: Fiberglass-reinforced PC and PBT
Minimum bending radius	90mm
Weight	Approx. 400g

■ Wiring

Pin No.		Signal name
Camera side Connector	Controller side Connector	
1	1	GND
14	14	GND
2	25	X0-
15	12	X0+
3	24	X1-
16	11	X1+
4	23	X2-
17	10	X2+
5	22	Xclk-
18	9	Xclk+
6	21	X3-
19	8	X3+
7	20	SerTC+
20	7	SerTC-
8	19	SerTCG-
21	6	SerTCG+
9	18	CC1-
22	5	CC1+
10	17	CC2+
23	4	CC2-
11	16	CC3-
24	3	CC3+
12	15	CC4+
25	2	CC4-
13	13	GND
26	26	GND



## Camera power cable (For F500-S□, F210-S□ Cameras)

## F500-VSP

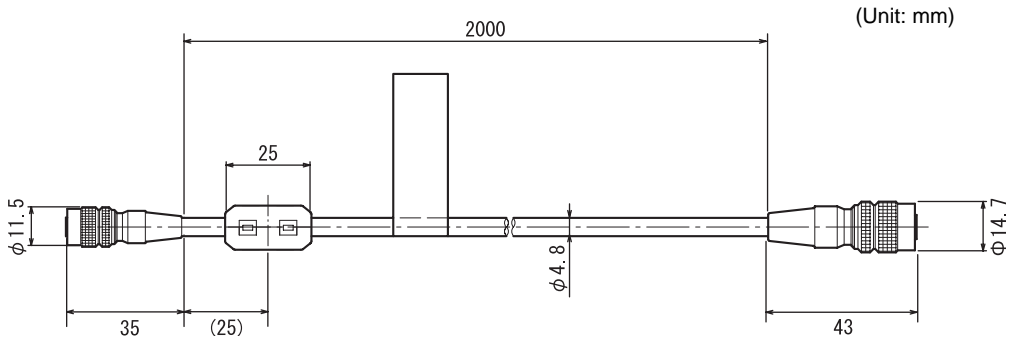

## General specifications

Vibration resistance	10 to 150Hz at a single-amplitude of 0.15mm, 4 times for 8 minutes each in 3 directions
Ambient Temperature	0 to 50°C at operation, -25 to 65°C at storage (with no icing nor condensation)
Ambient humidity	Operating and storage: 35% to 85% (with no condensation)
Ambient environment	No corrosive gases
Materials	Cable sheathing: Heat-resistant chlorinated vinyl Connector: Fiberglass-reinforced PC and PBT
Minimum bending radius	75mm
Weight	Approx. 120g

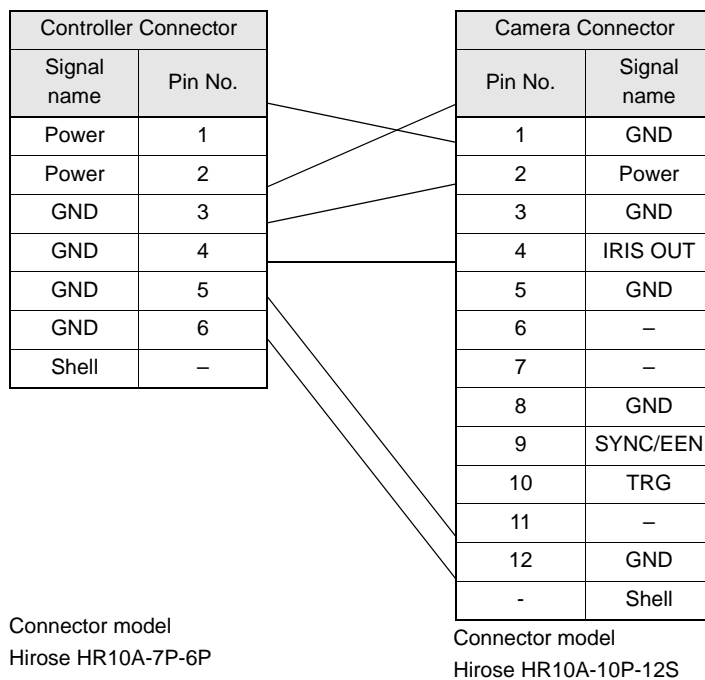

Monitor Cable  
 F150-VM

(Unit: mm)

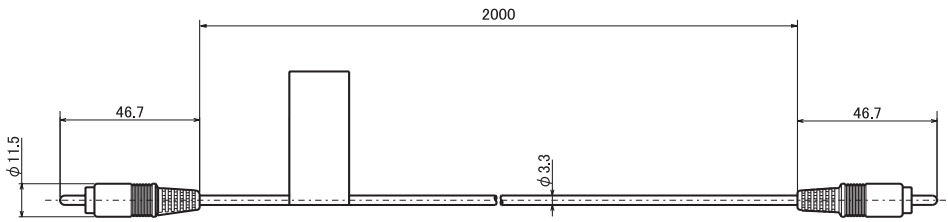

General specifications

Vibration resistance	10 to 150Hz at a single-amplitude of 0.15mm, 4 times for 8 minutes each in 3 directions
Ambient Temperature	0 to 50°C at operation, -25 to 65°C at storage (with no icing nor condensation)
Ambient humidity	Operating and storage: 35% to 85% (with no condensation)
Ambient environment	No corrosive gases
Materials	Cable sheathing: Super flame retardant PVC Connector: PVC
Minimum bending radius	50mm
Weight	Approx. 40g
Accessories	BNC jack adapter

Parallel I/O Cable  
F160-VP

(Unit: mm)

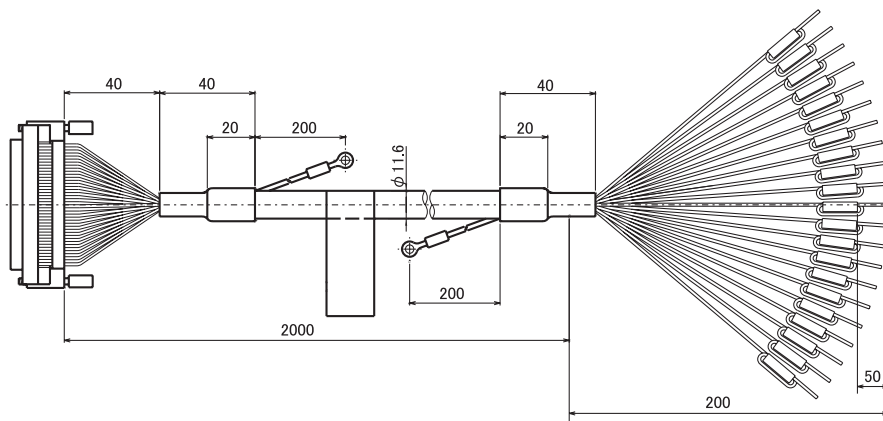

### General specifications

Vibration resistance	10 to 150Hz at a single-amplitude of 0.15mm, 4 times for 8 minutes each in 3 directions
Ambient Temperature	0 to 50°C at operation, -25 to 65°C at storage (with no icing nor condensation)
Ambient humidity	Operating and storage: 35% to 85% (with no condensation)
Ambient environment	No corrosive gases
Materials	Cable sheathing: Heat-resistant chlorinated vinyl Connector: Polyester resin
Minimum bending radius	120mm
Weight	Approx. 340g

# SECTION 5 Troubleshooting and Maintenance

## Color Liquid Crystal Display Monitor F500-M10L

(Unit: mm)

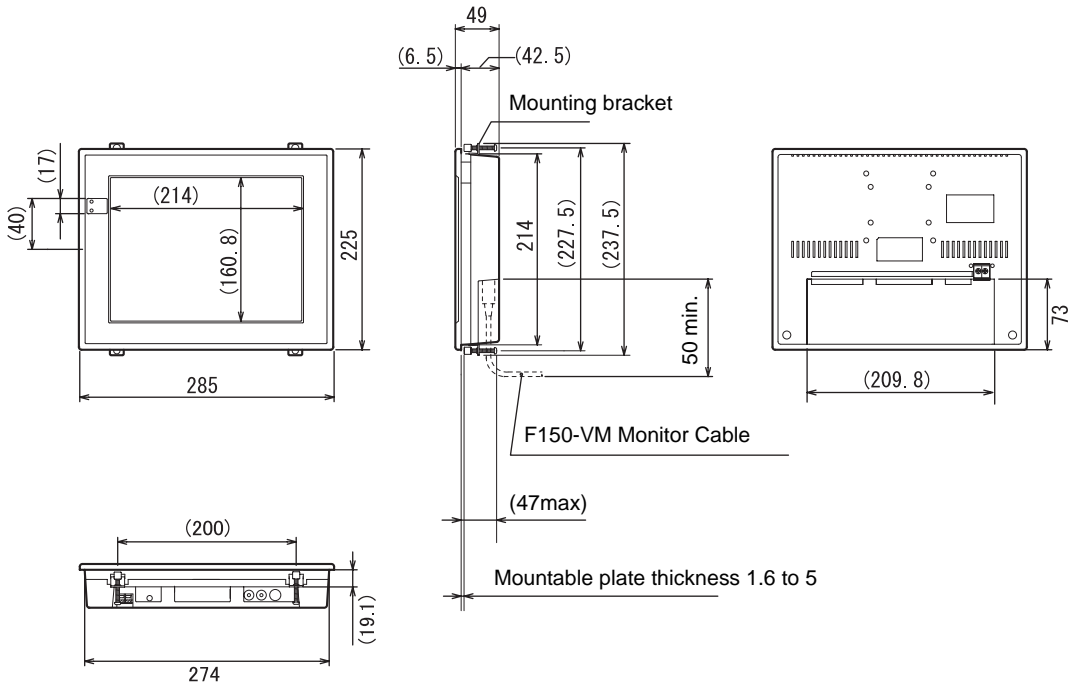

Panel cutout dimensions

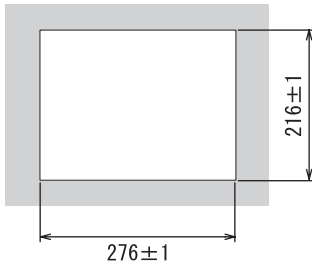

## General specifications

Power supply voltage	20.4 to 26.4V DC
Current consumption	1.0A max.
Vibration resistance	10 to 150Hz at a single-amplitude of 0.1mm (maximum acceleration: 15m/s <sup>2</sup> ), 10 times for 8 minutes each in 3 directions
Ambient Temperature	0 to 50°C at operation, -20 to 65°C at storage (with no icing nor condensation)
Ambient humidity	Operating and storage: 30% to 85% (with no condensation)
Ambient environment	No corrosive gases
Degree of protection	IEC60529 IP20
Materials	Case: ABS Display surface: PMMA (Acrylic)
Weight	Approx. 1.8kg
Accessories	Mounting bracket (x4) Ferrite core (x1)

## Performance specifications

Effective display area	10.4in. 211.2(H) × 158.4(V) mm
Panel type	TFT color liquid crystal display
Resolution	640x480 dots
Image pitch	0.33 (H) x 0.33 (V) mm
Contrast	300:1 (typical)
Viewable angle	45° up, 55° down, 70° left/right (with contrast ratio > 10)
Luminance	350cd/m <sup>2</sup> (typical)
Backlight	Cold-cathode tube edge light type
Input signal	NTSC composite video (1.0 V/75 Ω termination) S-Video Y signal (1.0V/75Ω termination), S-Video C signal (0.286V/75Ω termination)

Memory Cards  
 F160-N64S(S)  
 F160-N256S  
 QM300-N128S

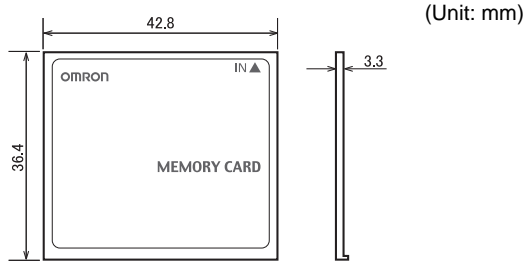

**General specifications**

Ambient Temperature	0 to 60°C at operation, -25 to 85°C at storage (with no icing nor condensation)
Ambient humidity	Operating and storage: 8% to 95% (with no condensation)
Ambient environment	No corrosive gases
Life expectancy	300,000 overwrite operations
Number of pins	50 pins
Weight	Approx. 15g

Application Software  
 F500-UM

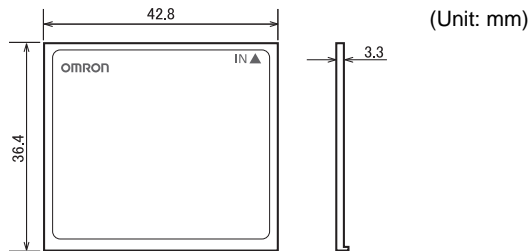

**General specifications**

Ambient Temperature	0 to 60°C at operation, -20 to 85°C at storage (with no icing nor condensation)
Ambient humidity	Operating and storage: 8% to 95% (with no condensation)
Ambient environment	No corrosive gases
Life expectancy	300,000 overwrite operations
Number of pins	50 pins
Weight	Approx. 15g

# Revision History

---

A manual revision code appears as a suffix to the catalog number on the cover of the manual.

Cat. No. SCHB-751A

↑  
revision code

Revision	Revision date	Revised content
A	January 2005	First edition





**OMRON CORPORATION**  
**Industrial Automation Company**

**Application Sensors Division**  
**Sensing Devices and Components Division H.Q.**  
Shiokoji Horikawa, Shimogyo-ku,  
Kyoto, 600-8530 Japan  
Tel: (81)75-344-7068/Fax: (81)75-344-7107

**Regional Headquarters**

**OMRON EUROPE B.V.**  
Sensor Business Unit,  
Carl-Benz-Str. 4, D-71154 Nufringen,  
Germany  
Tel: (49)7032-811-0/Fax: (49)7032-811-199

**OMRON ELECTRONICS LLC**  
1 East Commerce Drive, Schaumburg, IL 60173  
U.S.A.  
Tel: (1)847-843-7900/Fax: (1)847-843-8568

**OMRON ASIA PACIFIC PTE. LTD.**  
83 Clemenceau Avenue,  
#11-01, UE Square,  
239920 Singapore  
Tel: (65)6835-3011/Fax: (65)6835-2711

**OMRON CHINA CO., LTD. BEIJING OFFICE**  
Room 1028, Office Building,  
Beijing Capital Times Square,  
No. 88 West Chang'an Road,  
Beijing, 100031 China  
Tel: (86)10-8391-3005/Fax: (86)10-8391-3688

# OMRON

**Authorized Distributor:**