

Fixed Mount 2D Code Reader FQ-CR2 Quick Startup Guide

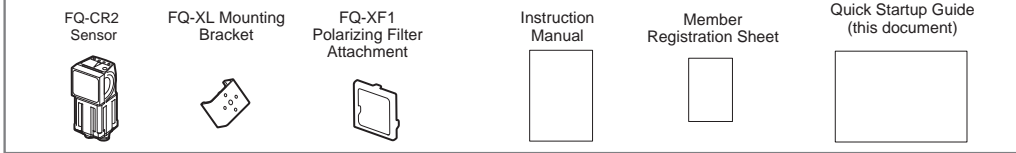

Box Contents



System Overview

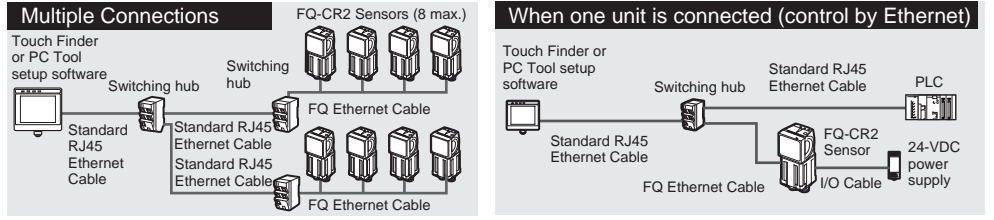
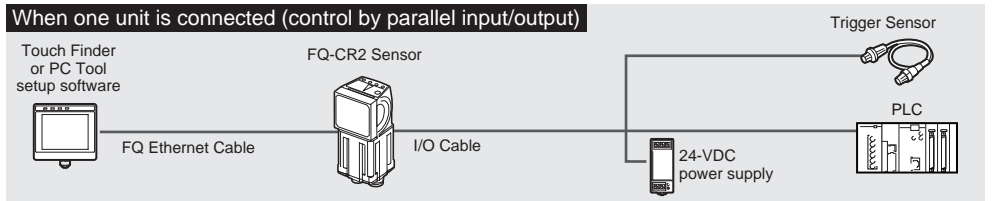

Product	Model number	Remarks
FQ-CR2 Sensor	FQ-CR2□□□□□-M	This is the Vision Sensor.
Touch Finder	FQ-D□□	This is a setup console. (Software Version 1.3 or higher)
PC Tool	---	The PC Tool can be used instead of the Touch Finder. (Software Version 1.3 or higher) If you register as a member, you can download the free PC Tool as a special service to purchasers. Refer to the Member Registration Sheet for member registration procedures and the download procedure for special member software.
FQ Ethernet Cable	FQ-WN0□□	Connects the Sensor to the Touch Finder or computer.
Standard RJ45 Ethernet Cable	---	Connects the switching hub to the Touch Finder or computer. (STP (shielded twisted-pair) cable, category 5e or 6, impedance: 100 Ω)
I/O Cable	FQ-WD0□□	Connects the Sensor to the power supply and external devices.

Flow of Operation

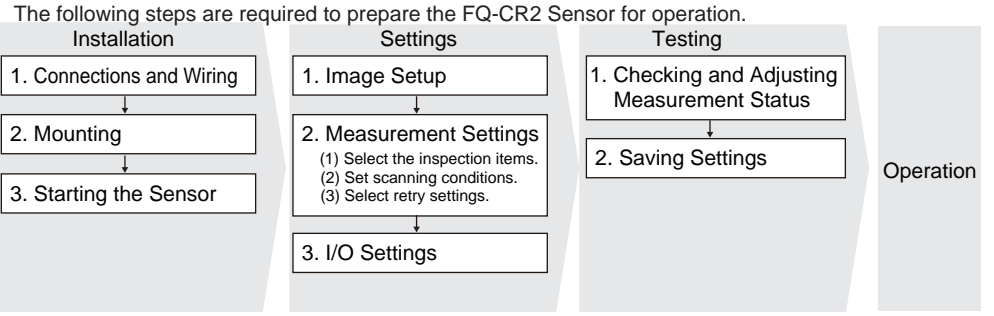

1. Installation

1-1 Connections and Wiring

1 Connect the Sensor to the Touch Finder or Computer via the FQ-WN0□□ Ethernet Cable.

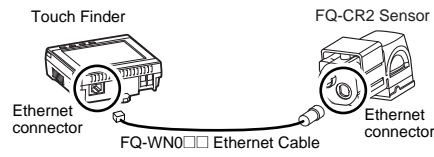

2 Connect the I/O Cable to the Sensor.

The I/O Cable includes lines for the power supply and I/O. Connect the required lines.

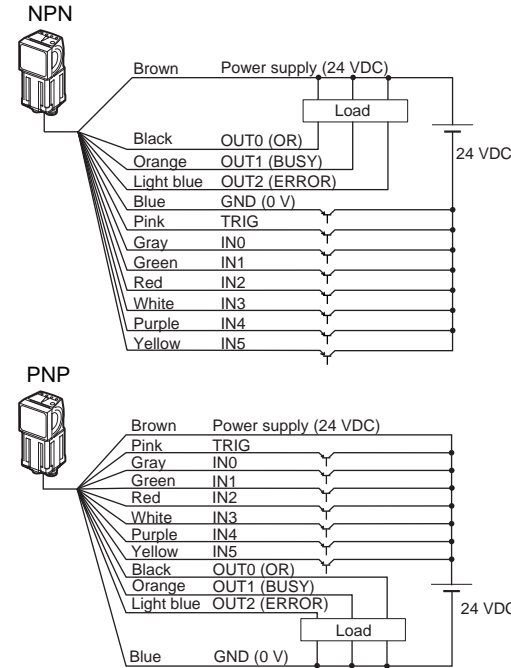

I/O	Signal	Function
Inputs	TRIG	Measurement trigger input (single)
	IN0 to IN5	Command input
Outputs	OUT0 (OR)	Overall judgement output
	OUT1 (BUSY)	Indicates that processing is in progress.
	OUT2 (ERROR)	Indicates an error has occurred.

Example 1

Here, measurements are performed when the trigger signal is input and the overall judgement is output.

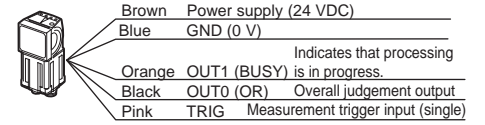

The TRIG signal is not received while the BUSY signal is ON. Turn ON the TRIG signal while the BUSY signal is OFF.

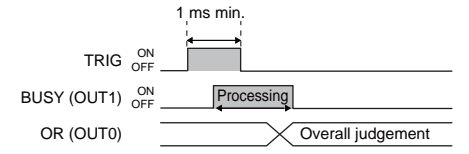

Important

- When brightness correction mode is ON, the brightness is stable but a delay of 25 ms occurs. Refer to the *User's Manual* for details.
- Use a no-contact output device (e.g., SSR or PLC transistor output) for the TRIG signal. If a contact (e.g., relay) is used, contact bound may cause the trigger to be input again during execution of a measurement.

Example 2

Here, a process switching signal is input from an external device to switch the scene.

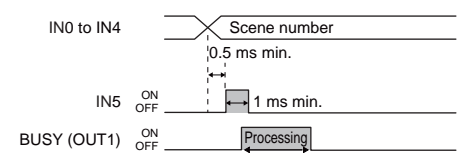
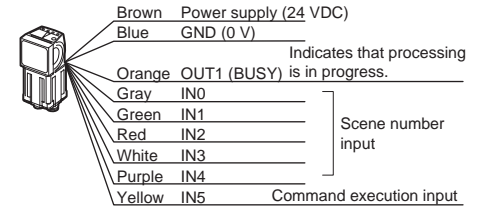

3 Connect a power supply to the Touch Finder.

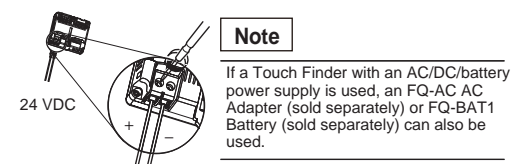

1-2 Mounting

1 Check the mounting position.

Use the optical charts in the enclosed Instruction Manual and check the installation distance to be sure it is suitable for the field of view to be measured.

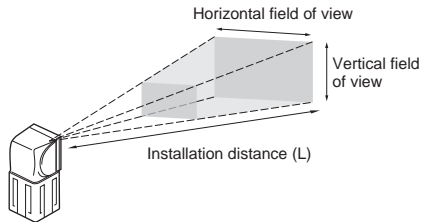

The horizontal field of view is given in the optical chart. The vertical field of view is approx. 60% of the horizontal field of view.

Example: FQ-CR20050F-M
For a 30-mm field of view, the Sensor must be installed at an installation distance of 115 mm.

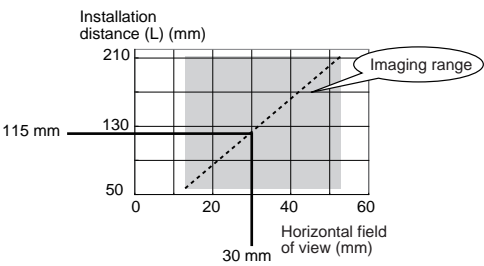

2 Attach the Mounting Bracket to the Sensor and mount the Sensor at the correct position.

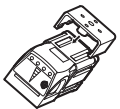

Installing the PC Tool

To use the PC Tool, register as a member, download the PC Tool, and install the PC Tool on your computer.

Use the following network settings on your computer if you connect the computer directly to the Sensor. If you connect the computer and Sensor through a hub using a DHCP server, the following IP address does not need to be set.

- IP address: 10.5.5.101
- Subnet mask: 255.255.255.0

1-3 Starting the Sensor

1 Power ON the Sensor.

2 Power ON the Touch Finder.

Turn ON the power switch on the side of the Touch Finder, too. Make sure that the version of Touch Finder or PC Tool setup software is 1.3 or higher.

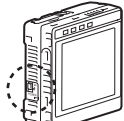

To use the PC Tool, click [Program] - [OMRON] - [FQ] - [PC tool for FQ] from the Windows Start Menu.

Select the language to display on the Touch Finder.



If more than one Sensor is connected, a display will appear to select the Sensor to be set. Select the Sensor.

The following initial display will appear when the Sensor is selected.



2. Settings

2-1 Switch to Setup Mode

Press the Button and then press [Sensor settings].

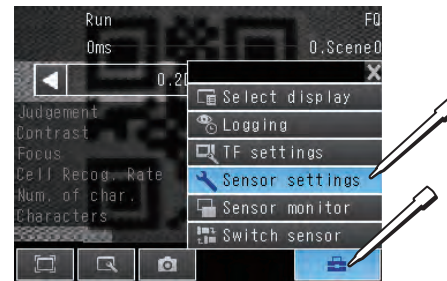

2-2 Image Setup

Make sure the image is stable and adjust the brightness and image input timing.

1 Focus the image.

Press [Camera setup].

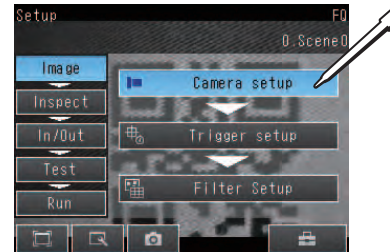

The camera image will be displayed.



The higher the value, the better the focus.

Use the focus adjustment screw on the top of the Sensor to focus the image.

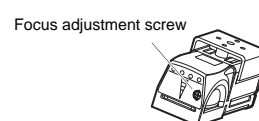

2 Adjust the brightness.

The FQ-CR2 Sensor will automatically adjust the brightness according to the measurement object. If the resulting brightness is not suitable, adjust the shutter speed manually.

Press [] and then [Shutter speed].

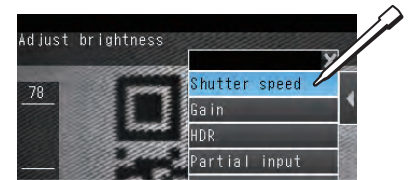

Adjust the shutter speed with the slider at the bottom of the screen.

You can also touch [AUTO] to automatically set the shutter speed and gain according to the image.



Press [OK].

Note

- Turning ON the [HDR] function improves the image quality for shiny objects. Refer to the *User's Manual* for details. When the [HDR] feature is used, the shutter speed and Gain settings are not used. Adjust the image with the Brightness setting only.
- Attach the enclosed Polarizing Filter if the image is blurred by reflections.

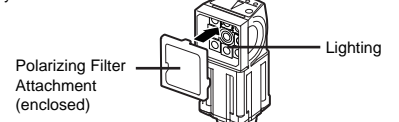

3 Adjust the image input timing.

Adjust the delay from when the trigger is input until the image is input. Press [Trigger setup].



Press [Trigger delay].



After the TRIG signal is input, images will be continuously input.



Select the image that was taken with the best timing. Press [OK].

4 Filter Setup

The filter can be set to filter the captured image so that it is suitable for scanning. Smooth, Dilate, Erosion, or Median can be specified for the filter. Normally the filter does not need to be set.

Refer to the User's Manual for details.

2-3 Measurement Settings

1 Select the inspection items.

Press [Inspect]. Next, touch [Inspection].

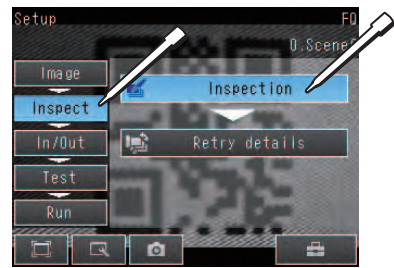

Touch [2D-code] - [Modify].

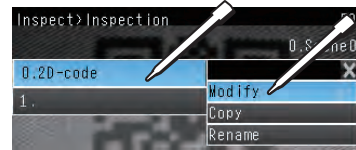

2 Set the 2D-code scanning conditions.

Press [Teach].

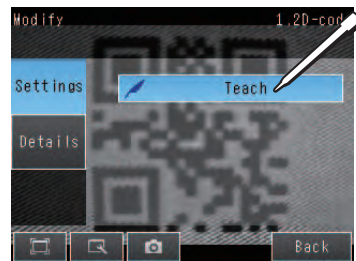

Make sure that the 2D-code is inside the green frame and touch [TEACH]. To change the inspection region, touch [◀] - [Insp. Region].



If scanning is successful, the 2D-code type and detected text string appear.



Press [Back].

If scanning failed, check the condition of the work and the lighting conditions, and repeat TEACH.

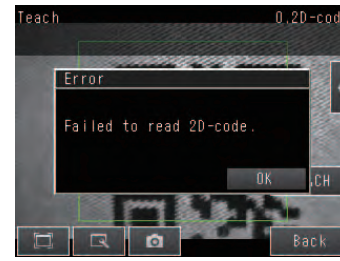

3 Select retry settings.

At one measurement trigger, this feature repeats scanning until the entire code is successfully read. Retry has four run modes: Normal retry, Exposure retry, Scene retry, and Trigger retry.

Touch (Setup Mode) - [Sensor settings] - [Retry details] - [Retry mode], and select the retry run mode.

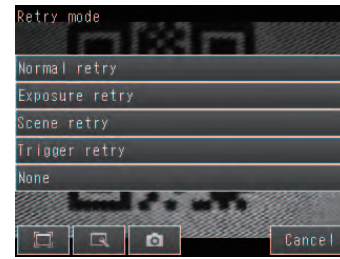

If you selected [Normal retry] or [Exposure retry], touch [Inspect] - [Retry details] and set the parameters.

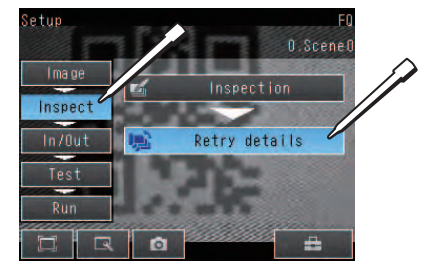

2-4 I/O Settings

Configure these settings if the 2D-code measurement data (Judgement, Num. of char., Cell Recog. Rate, Contrast, and Focus) and scanned text string are to be output by Ethernet.

Touch (Setup Mode) - [In/Out] - [I/O setting] - [Ethernet].

- Configure the output settings for the measurement data (Judgement, Num. of char., Cell Recog. Rate, Contrast, and Focus) in [Output data set].
- Configure the output settings for the scanned text string in [Output character set].

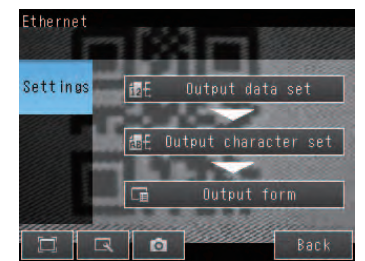

Refer to the User's Manual for details.

3. Testing

Tests are made with some samples to see if correct measurements are possible. When Test Mode is entered, images are measured continuously. A trigger input is not required. Measurement results are only displayed. They are not output to an external device.

1 Perform tests.

Press [Test]. Then press [Continuous test].

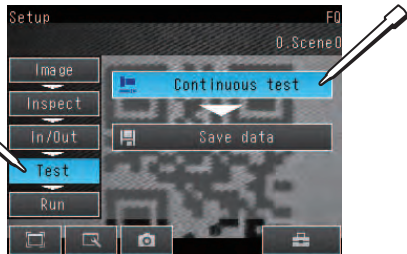

Press [Graphics+Details].

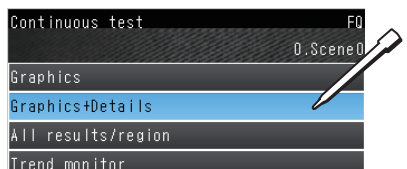

Continuous measurements will be performed. Input images of some samples to see if the judgements are correct.

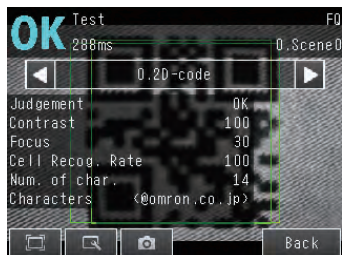

4. Operation

1 Switch to the Run Mode display.

Press [Run]. Then press [Switch to Run mode].



2 Save the settings.

Press [Yes].

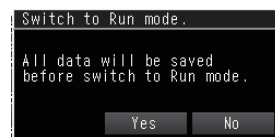

3 Execute measurements.

Measurements will be executed according to the trigger signal input. And the result of measurement will be output to an external device.



Note

There are six types of displays that can be used, as shown below. Press the (Button) and then press [Select display] to display the following selections.

Displaying the Most Recent Measurement Values



Displaying Measurement Values Over Time

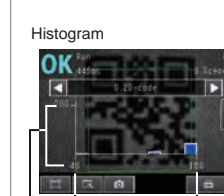

Variations in Measurement Values

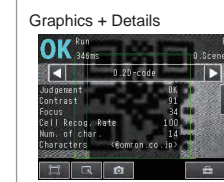

Measurement values

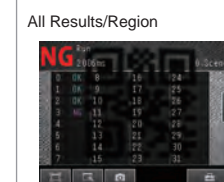

Measurement values since power was turned ON

Note

- To return to the Setup Display, press the (Button) and then press [Sensor settings].
- To switch to another Sensor, press the (Button) and then press [Switch sensor].

Menu Structure

