

CV Support Software Version 2: Offline

Operation Manual

Revised February 1993

< >

Ver. 2.00

DRV	[Functions]	DRV	[Functions]
C	P:Program	C	U:Convert UM
C	L:Program Link	C	M:Format floppy
C	H:Data Area Lists	C	G:Compare Prog.
C	S>Edit I/O names	C	X:COMMAND.COM
C	C>Edit I/O comments	O	0:End
C	W>Edit PC ID		
C	D>Edit DM		
C	I>Edit I/O table		
C	T:Data trace		
C	F:File management		
C	Q:System setup		
C	A:PC setup		
C	Z:Customize		
C	N:Network support table		
C	J:Memory card		

1 2 3 4 5 6 7 8 9 0

Notice:

OMRON products are manufactured for use according to proper procedures by a qualified operator and only for the purposes described in this manual.

The following conventions are used to indicate and classify precautions in this manual. Always heed the information provided with them. Failure to heed precautions can result in injury to people or damage to the product.

DANGER! Indicates information that, if not heeded, is likely to result in loss of life or serious injury.

WARNING Indicates information that, if not heeded, could possibly result in loss of life or serious injury.

Caution Indicates information that, if not heeded, could result in relative serious or minor injury, damage to the product, or faulty operation.

OMRON Product References

All OMRON products are capitalized in this manual. The word "Unit" is also capitalized when it refers to an OMRON product, regardless of whether or not it appears in the proper name of the product.

The abbreviation "Ch," which appears in some displays and on some OMRON products, often means "word" and is abbreviated "Wd" in documentation in this sense.

The abbreviation "PC" means Programmable Controller and is not used as an abbreviation for anything else.

Visual Aids

The following headings appear in the left column of the manual to help you locate different types of information.

Note Indicates information of particular interest for efficient and convenient operation of the product.

1, 2, 3... 1. Indicates lists of one sort or another, such as procedures, checklists, etc.

© OMRON, 1992

All rights reserved. No part of this publication may be reproduced, stored in a retrieval system, or transmitted, in any form, or by any means, mechanical, electronic, photocopying, recording, or otherwise, without the prior written permission of OMRON.

No patent liability is assumed with respect to the use of the information contained herein. Moreover, because OMRON is constantly striving to improve its high-quality products, the information contained in this manual is subject to change without notice. Every precaution has been taken in the preparation of this manual. Nevertheless, OMRON assumes no responsibility for errors or omissions. Neither is any liability assumed for damages resulting from the use of the information contained in this publication.

TABLE OF CONTENTS

SECTION 1

Introduction	1
1-1 Lists of Operations	2
1-2 Ladder Diagram Instructions	7
1-3 PC Data Areas	11
1-4 Abbreviations	13

SECTION 2

SFC Programming	15
2-1 Programming Menu	16
2-2 Clearing Memory	17
2-3 Memory Display	19
2-4 Changing SFC Settings	20
2-5 SFC Programming	24
2-6 Editing Action Blocks	32
2-7 Editing Steps and Transitions	38
2-8 Jumping and Searching	44
2-9 Checking SFC Programs	46
2-10 Reading and Writing Sheets	49
2-11 Saving and Retrieving Programs	52
2-12 Printing SFC Sheets	53
2-13 Overview Mode	59
2-14 Program View Mode	61

SECTION 3

Ladder Diagram Programming	63
3-1 Programming Menu	64
3-2 Clearing Memory	65
3-3 Memory Display	69
3-4 Switching the Display	70
3-5 Programming in Ladder Form	75
3-6 Creating Block Comments	99
3-7 Editing Instruction Blocks	101
3-8 Changing Addresses	103
3-9 Editing Interrupt Programs	111
3-10 Programming in the Mnemonic Display Mode	112
3-11 Checking the Program	119
3-12 Saving and Retrieving Programs	121
3-13 Printing	124

SECTION 4

Editing	129
4-1 Editing I/O Names	131
4-2 Editing I/O Comments	138
4-3 Linking Programs	142
4-4 Editing the Data Memory Area	151
4-5 Editing the I/O Table	157
4-6 Editing Network Support Tables	169
4-7 Editing PC IDs	186

SECTION 5

Data	193
5-1 Data Area Lists	194
5-2 Data Trace	197

SECTION 6	
Files	201
6-1 Initialization	202
6-2 File Management	203
6-3 UM Conversion	207
6-4 Comparing Programs	211
6-5 Memory Card Operations	213
SECTION 7	
Operating Parameters for the CVSS and PC	217
7-1 System Setup	218
7-2 PC Setup	221
7-3 Customization	239
Glossary	245
Index	269
Revision History	281

About this Manual:

This manual describes offline programming for the SYSMAC CV-series Programmable Controllers (PCs) using the CV500-CPU01-E, CV1000-CPU01-E, CV2000-CPU01-E, and CVM1-CPU01-E/11-E CPUs. Although the CV500, CV1000, and CV2000 support both SFC and ladder-diagram programming, the CVM1 supports only ladder-diagram programming and no information in this manual concerning SFC programming is applicable to it. This manual is designed to be used together with two other CVSS Operation Manuals. An introductory guide is also available. The entire set of CVSS manuals is listed below. Catalog number suffixes have been omitted; be sure you have the most recent version for your region.

Manual	Cat. No.
The CV Series Getting Started Guidebook	W203
CV Support Software Version 2 Operation Manual: Basics	W196
CV Support Software Version 2 Operation Manual: Offline	W201
CV Support Software Version 2 Operation Manual: Online	W200

This manual does not cover programming details and details on the operation of specific Units. The operation of the CV-series PCs is covered in the following three manuals. Catalog number suffixes have been omitted; be sure you have the most recent version for your region. Use these manuals together with the CVSS manuals. Manuals on any Link Units (e.g., SYSMAC NET Link Units, SYSMAC LINK Units, or SYSMAC BUS/2 Units) used with the PC will also be necessary.

Manual	Cat. No.
CV-series PC Operation Manual: SFC	W194
CV-series PC Operation Manual: Ladder Diagrams	W202
CV-series PC Operation Manual: Host Interface	W205

Please read this manual completely together with the other CV-series PC manuals, CVSS manuals, and Link Unit manual and be sure you understand the information provided before attempting to program or operate a CV-series PC. The basic content of each section of this manual is outlined below.

Section 1 provides basic reference material that should be useful when using the CVSS. The lists of operations include the main operations covered in the three CVSS manuals with page references to the proper manual. The tables of ladder-diagram instructions can be used to find instructions either by function code, functional group, or mnemonic. The PC data area tables outline the data areas available for use in programming, and the abbreviations are to aid reading CVSS displays.

Section 2 provides the procedures required to perform SFC programming.

Section 3 provides the procedures required to perform ladder diagram programming.

Section 4 provides the procedures required to edit programming.

Section 5 provides the procedures required to display and print data lists. Data can also be read from a data disk or hard disk by performing a data trace.

Section 6 provides the procedures required to manage files and perform UM conversion operations.

Section 7 describes the various parameters that can be set to control CVSS and PC operation and provides the procedures to change these parameters from their default settings. The System Setup contains parameters that control CVSS operations, such as the type of program being created or the PC that will be connected to for online operations. The PC Setup contains a wide range of parameters that can be used to control PC operation, including settings for controlling word allocation and error treatment. The Customize parameters enable changing function codes, data area prefixes, and data area boundaries.

SECTION 1

Introduction

This section provides basic reference material that should be useful when using the CVSS. The lists of operations include the main operations covered in the three CVSS manuals with page references to the proper manual. The tables of ladder-diagram instructions can be used to find instructions either by function code, functional group, or mnemonic. The PC data area tables outline the data areas available for use in programming, and the abbreviations are to aid reading CVSS displays. Read the CV500/CV1000 Operation Manuals and Installation Guide before using the CVSS.

1-1	Lists of Operations	2
1-1-1	System Settings and File Management (Online and Offline)	2
1-1-2	Offline Operations	2
1-1-3	Online Operations	5
1-2	Ladder Diagram Instructions	7
1-2-1	Function Codes	7
1-2-2	Alphabetic List of Mnemonics	9
1-3	PC Data Areas	11
1-4	Abbreviations	13

1-1 Lists of Operations

The following tables list the main operations available on CVSS menus.

1-1-1 System Settings and File Management (Online and Offline)

Page numbers refer to the *CV Support Software Version 2 Operation Manual: Offline*.

System Disks

The file compressing application DIET was used with CVSS. Refer to *CV Support Software Version 2: Basics* for installation of CVSS.

- Note**
1. MS-DOS is a registered trademark of the Microsoft Corporation.
 2. For the IBM PC/AT-compatible or PS/2 Model 50 computers (80286 machines), we recommend the user add a RAM disk with a memory size of 2M bytes minimum for smooth operation of the CVSS.

System Settings (CVSS Operating Environment)

Name	Description	Page
Destination Network Address	Used to specify the network address and node address of the PC with which the CVSS is to communicate.	218
Communications Specifications (offline)	Used to specify communications mode from Binary and ASCII for the PC and the connecting computer.	218
Memory Card Writer	Used to specify which communications port on the computer the Memory Card Writer is connected to.	221
Host Interface Specifications (online)	Used to specify the communications protocol for the CVSS to communicate with the PC via the host interface. The baud rate, PC unit number, parity, data length, and number of stop bits are designated.	161
Program Type	Used to specify whether the program will be written in ladder diagrams only or in SFC and ladder diagrams.	221
Printer Type	Used to specify the printer.	221
Program Check PC	Used to specify the model of PC for which program checks are to be run.	221
Message Number	Used to specify which messages are to be displayed on the CVSS from the message programmed into the PC with the MESSAGE instruction.	221

File Management

Name	Description	Page
File Directory	Used to display a list of files according to file type designations.	204
Copy File	Used to copy files either within the same disk or from one disk to another.	204
Change File Name	Used to change the name of an existing file.	205
Delete File	Used to delete an existing file.	205
Change Drive Path	Used to change the drive path name to which files are saved.	205
Create/Delete Directory	Used to create new directories or to delete existing directories.	205
Print	Used to print the specified list of files.	206

1-1-2 Offline Operations

Page numbers refer to the *CV Support Software Version 2 Operation Manual: Offline*.

Programming in SFC Detail

The operations in the following table are not supported by CVM1 PCs.

View Mode

Name	Description	Page
Clear Memory	Used to delete SFC programs, ladder diagram programs (including line comments), I/O names, and I/O comments from the work disk. Can also be used to delete only the SFC program or specified sheets of an SFC program.	17
Display Memory	Used to display the amount of PC user memory, internal memory, I/O names, I/O comments, and line comments used.	19

Name	Description	Page
Change SFC Settings	Used to specify the following parameters for creating SFC programs: If numbers and other inputs are to be made immediately upon creating SFC parts. Whether I/O names or addresses are to be used in SFC parts. The number of rows of SFC parts to display. The sheet size.	20
Writing SFC Parts	Used to create steps, actions, and other SFC parts on-screen.	26
Inputting Text for SFC Parts	Used to input addresses, I/O names, etc., for SFC parts.	27
Deleting SFC Parts	Used to delete SFC parts one at a time from the screen.	32
Edit Action	Used to create action blocks for each SFC step.	32
Edit Step/Transition	Used to modify SFC programs by inserting blank lines, inserting blank columns, deleting lines, deleting columns, and deleting/copying/moving specified regions of SFC programs.	38
Jump	Used to move the cursor to specified locations.	44
Find	Used to search for steps, transitions, or actions.	44
Check Program (SFC)	Used to check the SFC program displayed on the screen. The check is conducted according to the PC model set in the system settings and the specified check level. Three check levels are available.	46
Write/Read Sheet	Used to write SFC programs from the display buffer to the work disk or to read SFC program from the work disk to the display buffer.	49
Save Program	Used to save programs from the work disk to a data disk. All ladder-diagram programs written in program view are also saved.	52
Retrieve Program	Used to retrieve programs from data disk to the work disk. All ladder-diagram programs written in program view are also retrieved.	53
Print SFC Sheet	Used to print either all SFC sheets on the work disk or the sheet presently in the display buffer.	53
Overview	Used to display a wide range of an SFC program from memory.	59
Program View	Used to enable editing of action programs and transition programs.	61

Programming in SFC Program View or Ladder-only Mode

Name	Description	Page
Clear Memory	Used to delete ladder diagram programs from a specified address on when SFC programs are used or a specified program block when only ladder diagrams are used.	65
Display Memory	Used to display the amount of PC user memory, internal memory, I/O names, I/O comments, and line comments used. This operation is not supported in the SFC program view mode.	69
Change Display	Used to switch the display form for ladder diagrams between ladder diagrams with I/O addresses and I/O names; ladder diagrams with I/O addresses only; ladder diagrams with I/O names only; ladder diagrams with 2 lines of I/O comments; I/O addresses and I/O comments; ladder diagrams with 4 lines of I/O comments; or mnemonic ladder diagrams.	70
Writing Programs	Used to create programs in the display form designated above.	77
Store/Store Insert	Used to write programs onto the work disk. Not necessary when writing programs directly in mnemonic form.	90
Read Program	Used to read programs from the work disk in the designated display form.	93
Find	Used to search for instructions (including operands), I/O comments, or line comments.	93
Modifying Programs	Used to change existing programs.	86
Writing Line Comments	Used to create or modify line comments created in ladder diagrams.	99
Edit Section	Used to move, copy, or delete sections of ladder diagrams.	101
Change Block	Used to globally change bit or word addresses designated in programs on the work disk.	103

Name	Description	Page
Edit Interrupt Program	Used to create I/O interrupt, scheduled interrupt, power off interrupt, and power on interrupt programs. This operation is disabled if SFC programming is being used.	111
Check Program (Ladder)	Used to check the program on the work disk according to the PC model set in the system settings and the specified check level. Three check levels are available. Only ladder diagram-portions of the program are checked.	119
Save Program	Used to save programs or program sections from the work disk to a data disk. Only ladder-diagram portions of programs are saved.	121
Retrieve Program	Used to retrieve programs from a data disk to the work disk or to append programs from a data disk to the current program. Only ladder-diagram portions of the program are retrieved.	123
Print	Used to print ladder diagram portions of programs in normal ladder-diagram form or in mnemonic form.	124
Change C/CV mode	Used to change the ladder diagram input mode between C mode and CV mode.	78

Edit DM Operations

Name	Description	Page
Read DM Address	Used to display DM data from the work disk up to 160 words at a time. Displayed data can be modified.	153
Copy	Used to copy DM data on the work disk.	153
Fill	Used to write the same content to multiple DM words on the work disk.	153
Print	Used to print a specified area of DM from the work disk.	154
HEX <-> ASCII	Used to specify whether DM data is to be written in hexadecimal or ASCII.	154
Switch Bank Number	Used to specify the Expansion DM bank on the work disk (for CV1000 PCs only).	155
Save DM	Used to save DM data from the work disk to a data disk.	155
Retrieve DM	Used to retrieve DM data from a data disk to the work disk.	156
Save File	Used to save file data (with an .IOM) extension from the work disk to a data disk.	156
Retrieve File	Use to retrieve file data (with an .IOM extension) from a data disk to the work disk.	157

Edit I/O Table Operations

Name	Description	Page
Write I/O Table	Used to edit I/O table data on the work disk.	158
Check I/O Table	Used to check the contents of the I/O table on the work disk.	167
Save I/O Table	Used to save the I/O table on the work disk to a data disk.	168
Retrieve I/O Table	Used to retrieve an I/O table from a data disk to the work disk.	169
Clear I/O Table	Used to delete the I/O table from the work disk.	169
CPU Bus Units	Used to specify CPU Bus Unit classifications. This operation is presently not supported.	169
PC Setup	Used to set the addresses of the first words for local Racks and for group-1, group-2, and group-3 Slaves.	169

Other Operations

Name	Description	Page
Program Link	Used to join multiple programs on a data disk into one program on the work disk.	142
Edit I/O Name	Used to assign I/O names to bits; to edit, search for, or print existing I/O names; or to link I/O names to programs.	131
Edit I/O Comment	Used to write, edit, search for, or print I/O comments.	138
Display List	Used to create lists of various data or cross-references used in programs on the work disk and to display and/or print them.	194
Edit PC ID	Used to create, edit, search for, or print PC names.	186

Name	Description	Page
Data Tracing	Used to display the results of data traces created in online operations on the work disk.	197
PC Setup	Used to write various PC system parameters onto the work disk.	221
Customize	Used to change function codes, bit/word names, or memory area divisions.	239
Network Support Tables	Used to edit data link tables and routing tables for the SYSMAC NET and SYSMAC LINK Systems.	169
Memory Card	Used to display a list of all files on the memory card within the Memory Card Writer and permits access to these files. The Memory Card Writer is required if an EPROM-type memory card is used. A RAM-type memory card can be directly connected to the PC to enable online operation.	213
Convert UM	Used to convert the program code on the work disk to PC machine language and save it on a data disk. Also used to reverse this process.	207
Format floppy	Used to format floppy disks as data disks for CVSS data.	202
Compare prog.	Used to compare programs in a data disk with the program in the work file in the computer.	211
Command.Com (Basic)	Used to display a MS-DOS prompt. When the MS-DOS prompt is displayed, MS-DOS commands can be input.	34

1-1-3 Online Operations

Page numbers refer the *CV Support Software Version 2 Operation Manual: On-line*.

Transfer Program and Data

Name	Description	Page
Transfer Program and Data	Used to transfer programs, I/O names, DM (including Expansion DM), I/O tables, and the PC Setup between the CVSS and the PC. Data can be either converted to editable form and transferred to the work disk or transferred in machine language directly to a data disk. Also used to compare programs in the PC with those in the computer.	82

Monitoring in SFC Detail

The operations in the following table are not supported by CVM1 PCs.

View Mode

Name	Description	Page
Sheet Transfer	Used to transfer SFC sheets between the CVSS and the PC. Transferring sheets to the CVSS enables monitoring within those sheets.	16
Change SFC Settings	Used to specify the following parameters for creating SFC programs: If numbers and other inputs are to be made immediately upon creating SFC parts. Whether I/O names or addresses are to be used in SFC parts. The number of rows of SFC parts to display. The sheet size.	18
Action Display	Used to display the action block for a step and monitor action status.	20
Process Monitor	Used to monitor step and action status in list form.	21
All I/O Monitor	Used to monitor bits, words, timers, counters, steps, or transitions and to change bit status or word contents using the entire screen.	24
Part I/O Monitor	Used to monitor bits, words, timers, counters, steps, or transitions and to change bit status or word contents using the bottom third of the screen.	24
Step Status	Used to control step status (execute, pause, halt, inactive).	30
SFC Online Edit	Used to modify the SFC program in the PC.	25
Cross-reference	Used to display cross-references for any bit, word, or register.	25
Cycle Time Read	Used to read and display the cycle time of the PC.	28
Area Clear	Used to delete data from the user Program Area, CPU Bus Link Area, Auxiliary Area, Timer Area, Counter Area, DM Area, or Expansion DM Area in the PC.	29

Monitoring in SFC Program View or Ladder Mode

Name	Description	Page
Change Display	Used to switch the display form for ladder diagrams between ladder diagrams with I/O addresses and I/O names, ladder diagrams with I/O addresses only, ladder diagrams with I/O names only, ladder diagrams with 2 lines of I/O comments, or ladder diagrams with 4 lines of I/O comments.	35
Monitor Interrupt Program	Used to monitor I/O interrupt, scheduled interrupt, power off interrupt, and power on interrupt programs. This operation is disabled if SFC programming is being used.	52
All I/O Monitor	Used to monitor bits, words, timers, counters, steps, or transitions and to change bit status or word contents using the entire screen.	42
Part I/O Monitor	Used to monitor bits, words, timers, counters, steps, or transitions and to change bit status or word contents using the bottom third of the screen.	42
Online Edit	Used to modify the ladder-diagram portions of the program in the PC.	50
Cycle Time Read	Used to read and display the cycle time of the PC.	52
Display Memory	Used to display the amount of user memory used and the amount remaining.	35
Area Clear	Used to delete data from the User Program Area, CPU Bus Link Area, Auxiliary Area, Timer Area, Counter Area, DM Area, or Expansion DM Area in the PC.	54

Edit DM Operations

Name	Description	Page
Read DM Address	Used to display DM data from the PC up to 160 words at a time. Display data can be modified.	96
Copy	Used to copy DM data in the PC.	97
Fill	Used to write the same content to multiple DM words in the PC.	97
Print	Used to print a specified area of DM from the PC.	97
HEX <-> ASCII	Used to specify whether DM data is to be written in hexadecimal or ASCII.	97
Switch Bank Number	Used to specify the Expansion DM bank in the PC (for CV1000 PCs only).	98
Save DM	Used to save DM data from the PC to a data disk.	98
Retrieve DM	Used to retrieve DM data from a data disk to the PC.	99
Transfer DM	Used to transfer DM data between the PC and the CVSS and compare the contents.	99

Edit I/O Table Operations

Name	Description	Page
Transfer I/O Table	Used to transfer or compare the I/O table between the work disk in the CVSS and the PC.	92
Create I/O Table	Used to register in the PC the Units mounted to PC and allocate words to them.	93
Compare I/O Table	Used to compare the actual Units mounted to PC with the I/O table in the PC.	94
PC Setup	Used to set the addresses of the first words for local Racks and for group-1, group-2, and group-3 Slaves.	94

Other Operations

Name	Description	Page	
Debugging	Used to execute the program one step at a time or until certain conditions are met and to display step and action status. Debugging can be stopped in progress and monitoring operations used. Debugging operations are not supported by CVM1 PCs.	56	
Data Tracing	Used to trace data, display the results, and write the results to data disks.	60	
Program	Action	Used to trace actions and display the results.	68
Trace	Instruction	Used to trace instructions and display the results.	71
	Mark	Used to trace marks and display the results.	77

Name	Description	Page
PC Setup	Used to set parameters in the PC Setup.	163
Customize	Used to transfer customized settings from the CVSS to the PC.	164
CPU Bus Unit Setup	Used to set parameters for SYSMAC NET, SYSMAC LINK, and SYSMAC BUS/2 communications.	105
Network Support Tables	Used to transfer data link tables and routing tables between Link Units, the PC, and the CVSS and to compare these tables. Also used to start and start data links.	113
Network Diagnosis	Used to run tests between nodes, to read node status, and to read error logs from Units for the SYSMAC NET and SYSMAC LINK Systems. Also used for SYSMAC LINK Systems to run broadcast tests and set network parameters.	134
SYSMAC BUS/2	Used to manipulate SYSMAC BUS/2 Remote I/O Master Units.	141
Memory Cards	Used to display files lists from Memory Cards in the PC and to manipulate these files. Writing is not possible for EEPROM and EPROM cards.	152
Read Error	Used to read the current error and error logs. Also used to force release of the access right to a PC.	148
Clock	Used to set the clock in the PC.	149
Protect UM	Used to protect all or part of the user program by creating passwords. Program access will not be possible to protected sections without the proper password.	165

1-2 Ladder Diagram Instructions

This section provides tables of the ladder-diagram instructions for reference in inputting programs. The first table can be used to find instructions by function code. The second table can be used to find instruction by mnemonic.

Refer to the *CV-series PC Operation Manual: Ladder Diagrams* for programming details on ladder-diagram instructions.

1-2-1 Function Codes

The following table lists the instructions that have function codes. Each instruction is listed by mnemonic, with the variations given in parentheses afterward, and by instruction name. The function code for any instruction is derived by using the numbers in the leftmost column as the leftmost digits and the number in the column heading as the rightmost digit.

Code	Rightmost digit										Instruction group
	0	1	2	3	4	5	6	7	8	9	
00	NOP NO OPERATION	END END	IL INTER-LOCK	ILC INTER-LOCK CLEAR	JMP JUMP	JME JUMP END	FAL (j) FAILURE ALARM AND RESET	FALS SEVERE ALARM FAILURE	STEP STEP DEFINE	SNXT STEP START	Sequence Control Instructions
01	NOT NOT	KEEP (!) KEEP	CNTR REVERSIBLE COUNTER	DIFU (!) DIFFERENTIATE UP	DIFD (!) DIFFERENTIATE DOWN	TIMH HIGH-SPEED TIMER	SET (j!i) SET	RSET (j!i) RESET			
02	CMP (!) COMPARE	CMPL DOUBLE COMPARE	BCMP (j) BLOCK COMPARE	TCMP (j) TABLE COMPARE	MCMP (j) MULTIPLE COMPARE	EQU (j) EQUAL					Data Compare Instructions
03	MOV (j!) MOVE	MVN (j) MOVE NOT	MOVL (j) DOUBLE MOVE	MVNL (j) DOUBLE MOVE NOT	XCHG (j) DATA EXCHANGE	XCGL (j) DOUBLE DATA EXCHANGE	MOVR (j) MOVE TO REGISTER	MOVQ MOVE QUICK			Data Move Instructions
04	XFER (j) BLOCK TRANSFER	BSET (j) BLOCK SET	MOVB (j) MOVE BIT	MOVD (j) MOVE DIGIT	DIST (j) DATA DISTRIBUTE	COLL (j) DATA COLLECT					Data Shift Instructions
05	SFT SHIFT REGISTER	SFTR (j) REVERSIBLE SHIFT REGISTER	ASFT (j) ASYNCHRONOUS SHIFT REGISTER	WSFT (j) WORD SHIFT							Data Shift Instructions
06	ASL (j) SHIFT LEFT	ASR (j) SHIFT RIGHT	ROL (j) ROTATE LEFT	ROR (j) ROTATE RIGHT	ASLL (j) DOUBLE SHIFT LEFT	ASRL (j) DOUBLE SHIFT RIGHT	ROLL (j) DOUBLE ROTATE LEFT	RORL (j) DOUBLE ROTATE RIGHT	SLD (j) SHIFT DIGIT LEFT	SRD (j) SHIFT DIGIT RIGHT	

Code	Rightmost digit										Instruction group
	0	1	2	3	4	5	6	7	8	9	
07	ADD (j) BCD ADD	SUB (j) BCD SUBTRACT	MUL (j) BCD MULTIPLY	DIV (j) BCD DIVIDE	ADDL (j) DOUBLE BCD ADD	SUBL (j) DOUBLE BCD SUBTRACT	MULL (j) DOUBLE BCD MULTIPLY	DIVL (j) DOUBLE BCD DIVIDE	STC (j) SET CARRY	CLC (j) CLEAR CARRY	BCD Calculation Instructions
08	ADB (j) BINARY ADD	SBB (j) BINARY SUBTRACT	MLB (j) BINARY MULTIPLY	DVB (j) BINARY DIVIDE	ADBL (j) DOUBLE BINARY ADD	SBBL (j) DOUBLE BINARY SUBTRACT	MLBL (j) DOUBLE BINARY MULTIPLY	DVBL (j) DOUBLE BINARY DIVIDE			Binary Calculation Instructions
09	INC (j) INCREMENT BCD	DEC (j) DECREMENT BCD	INCB (j) INCREMENT BINARY	DECB (j) DECREMENT BINARY	INCL (j) DOUBLE INCREMENT BCD	DECL (j) DOUBLE DECREMENT BCD	INBL (j) DOUBLE INCREMENT BINARY	DCBL (j) DOUBLE DECREMENT BINARY			Increment/Decrement Instructions
10	BIN (j) BCD TO BINARY	BCD (j) BINARY TO BCD	BINL (j) DOUBLE BCD TO DOUBLE BINARY	BCDL (j) DOUBLE BINARY TO DOUBLE BCD	NEG (j) 2'S COMPLEMENT	NEGL (j) DOUBLE 2'S COMPLEMENT	SIGN (j) SIGN				Data Format Conversion Instructions
11	MLPX (j) 4-TO-16 DECODER	DMPX (j) 16-TO-4 ENCODER	SDEC (j) 7-SEGMENT DECODER	ASC (j) ASCII CONVERT	BCNT (j) BIT COUNTER	LINE (j) COLUMN TO LINE	COLM (j) LINE TO COLUMN				Data Conversion Functions
12	TTIM ACCUMULATIVE TIMER	TIML LONG TIMER	MTIM MULTI-OUTPUT TIMER	TCNT TRANSITION COUNTER	TSR (j) READ STEP TIMER	TSW (j) WRITE STEP TIMER					Special Counter and Timer Instructions
13	ANDW (j) LOGICAL AND	ORW (j) LOGICAL OR	XORW (j) EXCLUSIVE OR	XNRW (j) EXCLUSIVE NOR	ANDL (j) DOUBLE LOGICAL OR	ORWL (j) DOUBLE LOGICAL OR	XORL (j) DOUBLE EXCLUSIVE OR	XNRL (j) DOUBLE EXCLUSIVE NOR	COM (j) COMPLEMENT	COML (j) DOUBLE COMPLEMENT	Logical Instructions
14	ROOT (j) SQUARE ROOT	FDIV (j) FLOATING POINT DIVIDE	APR (j) ARITHMETIC PROCESS	SEC (j) HOURS TO SECONDS	HMS (j) SECONDS TO HOURS	CADD (j) CALENDAR ADD	CSUB (j) CALENDAR SUBTRACT				Special Instructions
15	SBN SUBROUTINE ENTRY	SBS (j) SUBROUTINE CALL	RET SUBROUTINE RETURN	MSKS (j) INTERUPT MASK	CLI (j) CLEAR INTERRUPT	MSKR (j) READ MASK					Subroutine Instructions Interrupt Instructions
16	SSET (j) SET STACK	PUSH (j) PUSH ONTO STACK	LIFO (j) LAST-IN, FIRST-OUT	FIFO (j) FIRST-IN, FIRST-OUT	SRCH (j) DATA SEARCH	MAX (j) FIND MAXIMUM	MIN (j) FIND MINIMUM	SUM (j) SUM			Table Data Processing Instructions
17	TRSM TRACE MEMORY	EMBC (j) SELECT DM BANK	CCL (j) LOAD FLAGS	CCS (j) SAVE FLAGS	MARK MARK TRACE	REGL (j) LOAD REGISTER	REGS (j) SAVE REGISTER				Trace Instructions Special Instructions
18	FILR (j) READ DATA FILE	FILW (j) WRITE DATA FILE	FILP (j) READ PROGRAM FILE	FLSP (j) CHANGE STEP PROGRAM	IORF (j) I/O REFRESH			IOSP (j) DISABLE ACCESS	IORS ENABLE ACCESS	IODP (j) I/O DISPLAY	File Processing Instructions and
19	READ READ I/O	WRIT WRITE I/O	SEND (j) NETWORK SEND	RECV (j) NETWORK RECEIVE	CMND (j) DELIVER COMMAND	MSG (j) MESSAGE					I/O Processing Instructions
20			TOUT TRANSITION OUTPUT								SFC Control Instructions
21	SA (j) ACTIVATE STEP	SP (j) PAUSE STEP	SR (j) RESTART STEP	SF (j) END STEP	SE (j) DEACTIVATE STEP	SOFF (j) RESET STEP					
22											---
23							CNR (j) RESET TIMER/COUNTER				---

1-2-2 Alphabetic List of Mnemonics

Mnemonic	Code	Name
ADB (j)	080	BINARY ADD
ADBL (j)	084	DOUBLE BINARY ADD
ADD (j)	070	BCD ADD
ADDL (j)	074	DOUBLE BCD ADD
AND (!ji)	None	AND
ANDL (j)	134	DOUBLE LOGICAL AND
AND LD	None	AND LOAD
AND NOT (!)	None	AND NOT
ANDW (j)	130	LOGICAL AND
APR (j)	142	ARITHMETIC PROCESS
ASC (j)	113	ASCII CONVERT
ASFT (j)	052	ASYNCHRONOUS SHIFT REGISTER
ASL (j)	060	ARITHMETIC SHIFT LEFT
ASLL (j)	064	DOUBLE SHIFT LEFT
ASR (j)	061	ARITHMETIC SHIFT RIGHT
ASRL (j)	065	DOUBLE SHIFT RIGHT
BCD (j)	101	BINARY-TO-BCD
BCDL (j)	103	DOUBLE BINARY-TO-DOUBLE BCD
BCMP (j)	022	BLOCK COMPARE
BCNT (j)	114	BIT COUNTER
BIN (j)	100	BCD-TO-BINARY
BINL (j)	102	DOUBLE BCD-TO-DOUBLE BINARY
BSET (j)	041	BLOCK SET
CADD (j)	145	CALENDAR ADD
CCL (j)	172	LOAD FLAGS
CCS (j)	173	SAVE FLAGS
CLC (j)	079	CLEAR CARRY
CLI (j)	154	CLEAR INTERRUPT
CMND (j)	194	DELIVER COMMAND
CMP (!)	020	COMPARE
CMPL	021	DOUBLE COMPARE
CNR (j)	236	RESET TIMER/COUNTER
CNT	None	COUNTER
CNTR	012	REVERSIBLE COUNTER
COLL (j)	045	DATA COLLECT
COLM (j)	116	LINE TO COLUMN
COM (j)	138	COMPLEMENT
COML (j)	139	DOUBLE COMPLEMENT
CSUB (j)	146	CALENDAR SUBTRACT

Mnemonic	Code	Name
DCBL (j)	097	DOUBLE DECREMENT BINARY
DEC (j)	091	DECREMENT BCD
DECB (j)	093	DECREMENT BINARY
DECL (j)	095	DOUBLE DECREMENT BCD
DIFD (!)	014	DIFFERENTIATE DOWN
DIFU (!)	013	DIFFERENTIATE UP
DIST (j)	044	SINGLE WORD DISTRIBUTE
DIV (j)	073	BCD DIVIDE
DIVL (j)	077	DOUBLE BCD DIVIDE
DMPX (j)	111	16-TO-4 ENCODER
DVB (j)	083	BINARY DIVIDE
DVBL (j)	087	DOUBLE BINARY DIVIDE
EMBC (j)	171	SELECT EM BANK
END	001	END
EQU (j)	025	EQUAL
FAL (j)	006	FAILURE ALARM
FALS (j)	007	FAILURE ALARM
FDIV (j)	141	FLOATING POINT DIVIDE
FIFO (j)	163	FIRST IN FIRST OUT
FILP (j)	182	READ PROGRAM FILE
FILR (j)	180	READ DATA FILE
FILW (j)	181	WRITE DATA FILE
FLSP (j)	183	CHANGE STEP PROGRAM
HMS (j)	144	SECONDS TO HOURS
IL	002	INTERLOCK
ILC	003	INTERLOCK CLEAR
INBL (j)	096	DOUBLE INCREMENT BINARY
INC (j)	090	INCREMENT BCD
INCB (j)	092	INCREMENT BINARY
INCL (j)	094	DOUBLE INCREMENT BCD
IODP (j)	189	I/O DISPLAY
IORF (j)	184	I/O REFRESH
IORS	188	ENABLE ACCESS
IOSP (j)	187	DISABLE ACCESS
JME	005	JUMP END
JMP	004	JUMP
KEEP (!)	011	KEEP
LD (!ji)	None	LOAD
LD NOT (!)	None	LOAD NOT

Mnemonic	Code	Name
LIFO (j)	162	LAST IN FIRST OUT
LINE (j)	115	COLUMN TO LINE
MARK	174	MARK TRACE
MAX (j)	165	FIND MAXIMUM
MCMP (j)	024	MULTIPLE COMPARE
MIN (j)	166	FIND MINIMUM
MLB (j)	082	BINARY MULTIPLY
MLBL (j)	086	DOUBLE BINARY MULTIPLY
MLPX (j)	110	4-TO-16 DECODER
MOV (!j)	030	MOVE
MOVB (j)	042	MOVE BIT
MOVD (j)	043	MOVE DIGIT
MOVL (j)	032	DOUBLE MOVE
MOVQ	037	MOVE QUICK
MOVR (j)	036	MOVE TO REGISTER
MSG (j)	195	MESSAGE
MSKR (j)	155	READ MASK
MSKS (j)	153	INTERRUPT MASK
MTIM	122	MULTI-OUTPUT TIMER
MUL (j)	072	BCD MULTIPLY
MULL (j)	076	DOUBLE BCD MULTIPLY
MVN (j)	031	MOVE NOT
MVNL (j)	033	DOUBLE MOVE NOT
NEG (j)	104	2'S COMPLEMENT
NEGL (j)	105	DOUBLE 2'S COMPLEMENT
NOP	000	NO OPERATION
NOT	010	NOT
OR (!ji)	None	OR
OR NOT (!)	None	OR NOT
OR LOAD	None	OR LOAD
ORW (j)	131	LOGICAL OR
ORWL (j)	135	DOUBLE LOGICAL OR
OUT (!)	None	OUTPUT
OUT NOT (!)	None	OUTPUT NOT
PUSH (j)	161	PUSH ONTO STACK
READ	190	I/O READ
RCV (j)	193	NETWORK RECEIVE
REGL (j)	175	LOAD REGISTER
REGS (j)	176	SAVE REGISTER
RET	152	SUBROUTINE RETURN
ROL (j)	062	ROTATE LEFT

Mnemonic	Code	Name
ROLL (j)	066	DOUBLE ROTATE LEFT
ROOT (j)	140	SQUARE ROOT
ROR (j)	063	ROTATE RIGHT
RORL (j)	067	DOUBLE ROTATE RIGHT
RSET (!ji)	017	RSET
SA (j)	210	ACTIVATE STEP
SBB (j)	081	BINARY SUBTRACT
SBBL (j)	085	DOUBLE BINARY SUBTRACT
SBN	150	SUBROUTINE ENTER
SBS (j)	151	SUBROUTINE CALL
SDEC (j)	112	7-SEGMENT DECODER
SE (j)	214	DEACTIVATE STEP
SEC (j)	143	HOURS TO SECONDS
SEND (j)	192	NETWORK SEND
SET (!ji)	016	SET
SF (j)	213	END STEP
SFT	050	SHIFT REGISTER
SFTR (j)	051	REVERSIBLE SHIFT REGISTER
SIGN (j)	106	SIGN
SLD (j)	068	SHIFT DIGIT LEFT
SNXT	009	STEP START
SOFF (j)	215	RESET STEP
SP (j)	211	PAUSE STEP
SR (j)	212	RESTART STEP
SRCH (j)	164	DATA SEARCH
SRD (j)	069	SHIFT DIGIT RIGHT
SSET (j)	160	SET STACK
STC (j)	078	SET CARRY
STEP	008	STEP DEFINE
SUB (j)	071	BCD SUBTRACT
SUBL (j)	075	DOUBLE BCD SUBTRACT
SUM (j)	167	SUM
TCMP (j)	023	TABLE COMPARE
TCNT	123	TRANSITION COUNTER
TIM	None	TIMER
TIMH	015	HIGH-SPEED TIMER
TIML	121	LONG TIMER
TOUT	202	TRANSITION OUTPUT
TRSM	170	TRACE MEMORY
TSR (j)	124	READ STEP TIMER
TSW (j)	125	WRITE STEP TIMER

Mnemonic	Code	Name
TTIM	120	ACCUMULATIVE TIMER
WRIT	191	I/O WRITE
WSFT (j)	053	WORD SHIFT
XGGL (j)	035	DOUBLE DATA EXCHANGE
XCHG (j)	034	DATA EXCHANGE

Mnemonic	Code	Name
XFER (j)	040	BLOCK TRANSFER
XNRL (j)	137	DOUBLE EXCLUSIVE NOR
XNRW (j)	133	EXCLUSIVE NOR
XORL (j)	136	DOUBLE EXCLUSIVE OR
XORW (j)	132	EXCLUSIVE OR

1-3 PC Data Areas

The following table outlines the data areas provided in the PC. Refer to the *CV-series PC Operation Manual: Ladder Diagrams* for programming details on ladder-diagram instructions.

Area	PC	Range	Function
I/O Area	CV500-CPU01-E CVM1-CPU01-E	Words: CIO 0000 to CIO 0031 Bits: CIO 000000 to CIO 003115 (\$0000 to \$001F)	Allocated to I/O in the System and used to control I/O points. Bits not used to control I/O points can be used as work bits. The PC Setup can be used to control allocations. Once I/O table has been registered, input bits are displayed on CVSS with an I; output bits, with a Q.
	CV1000-CPU01-E CVM1-CPU11-E	Words: CIO 0000 to CIO 0063 Bits: CIO 000000 to CIO 006315 (\$0000 to \$003F)	
	CV2000-CPU01-E	Words: CIO 0000 to CIO 0127 Bits: CIO 000000 to CIO 012715 (\$0000 to \$007F)	
Work Area	CV500-CPU01-E CVM1-CPU01-E	Words: CIO 0032 to CIO 0199 Bits: CIO 003200 to CIO 019915 (\$0020 to \$00C7)	These bits are used in the program to manipulate or to temporarily store data.
	CV1000-CPU01-E CVM1-CPU11-E	Words: CIO 0064 to CIO 0199 Bits: CIO 006400 to CIO 019915 (\$0040 to \$00C7)	
	CV2000-CPU01-E	Words: CIO 0128 to CIO 0199 Bits: CIO 012800 to CIO 019915 (\$0080 to \$00C7)	
SYSMAC BUS/2 Area	CV500-CPU01-E CVM1-CPU01-E	Words: CIO 0200 to CIO 0599 Bits: CIO 020000 to CIO 059915 (\$00C8 to \$0257)	These bits are used for remote I/O points in the SYSMAC BUS/2 Remote I/O System unless the default allocations are changed in the PC Setup. Bits not used to control I/O points can be used as work bits.
	CV1000-CPU01-E CV2000-CPU01-E CVM1-CPU11-E	Words: CIO 0200 to CIO 0999 Bits: CIO 020000 to CIO 099915 (\$00C8 to \$03E7)	
Link Area	All	Words: CIO 1000 to CIO 1199 Bits: CIO 100000 to CIO 119915 (\$03E8 to \$04AF)	These bits are used for SYSMAC NET Link and SYSMAC LINK Systems. Bits not used for data links can be used as work bits. These bits can be set as holding bits via PC Setup.
Holding Area	All	Words: CIO 1200 to CIO 1499 Bits: CIO 120000 to CIO 149915 (\$04B0 to \$05DB)	Used to store data and to retain the data values when the power is turned off.
CPU Bus Unit Area	All	Words: CIO 1500 to CIO 1899 Bits: CIO 150000 to CIO 189915 (\$05DC to \$076B)	Used to store the operating status of CPU Bus Units. Bits not used by CPU Bus Units can be used as work bits. These bits can be set as holding bits via the PC Setup.
Work Area	All	Words: CIO 1900 to CIO 2299 Bits: CIO 190000 to CIO 229915 (\$076C to \$08FB)	These bits are used in the program to manipulate or to temporarily store data. These bits can be set as holding bits via the PC Setup.

Area	PC	Range	Function
SYSMAC BUS Area	CV500-CPU01-E CVM1-CPU01-E	Words: CIO 2300 to CIO 2427 Bits: CIO 230000 to CIO 242715 (\$08FC to \$097B)	These bits are used for remote I/O points in the SYSMAC BUS Remote I/O System unless the default allocations are changed in the PC Setup. Bits not used to control I/O points can be used as work bits. Up to word 2399 can be set as holding bits via the PC Setup.
	CV1000-CPU01-E CV2000-CPU01-E CVM1-CPU11-E	Words: CIO 2300 to CIO 2555 Bits: CIO 230000 to CIO 255515 (\$08FC to \$09FB)	
Temporary Relay Area	All	TR0 to TR7 (bits only) (\$09FF)	Used to temporarily store execution conditions. TR bits are not input when programming directly in ladder diagrams.
CPU Bus Link Area	All	Words: G000 to G255 Bits: G00000 to G25515 (\$0A00 to \$0AFF)	G000 is the PC Status Area; G001 to G004, the Clock Area. G008 to G127 contain PC output bits; G128 to G255, CPU Bus Unit output bits.
Auxiliary Area	All	Words: A000 to A511 Bits: A00000 to A51115 (\$0B00 to \$0CFF)	Contains flags and bits with special functions.
Transition Area	CV500-CPU01-E	TN0000 to TN0511 (\$0D00 to \$0D1F)	Transition Flags for the transitions in the SFC program.
	CV1000-CPU01-E CV2000-CPU01-E	TN0000 to TN1023 (\$0D00 to \$0D3F)	
Step Area	CV500-CPU01-E	ST0000 to ST0511 (\$0E00 to \$0E1F)	Step Flags for the steps in the SFC program. A step is active when its flag is ON.
	CV1000-CPU01-E CV2000-CPU01-E	ST0000 to ST1023 (\$0E00 to \$0E3F)	
Timer Area	CV500-CPU01-E CVM1-CPU01-E	T0000 to T0511 (Completion Flags: \$0F00 to \$0F1F Present Values: \$1000 to \$11FF)	Used to define timers (normal, high-speed, and totalizing) and to access Completion Flags, PV, and SV.
	CV1000-CPU01-E CV2000-CPU01-E CVM1-CPU11-E	T0000 to T1023 (Completion Flags: \$0F00 to \$0F3F Present Values: \$1000 to \$13FF)	
Counter Area	CV500-CPU01-E CVM1-CPU01-E	C0000 to C0511 (Completion Flags: \$0F80 to \$0F9F Present Values: \$1800 to \$19FF)	Used to define counters (normal, reversible, and transition) and to access Completion Flags, PV, and SV.
	CV1000-CPU01-E CV2000-CPU01-E CVM1-CPU11-E	C0000 to C1023 (Completion Flags: \$0F80 to \$0FBF Present Values: \$1800 to \$1BFF)	
DM Area	CV500-CPU01-E CVM1-CPU01-E	D00000 to D08191 (\$2000 to \$3FFF)	Used for internal data storage and manipulation.
	CV1000-CPU01-E CV2000-CPU01-E CVM1-CPU11-E	D00000 to D24575 (\$2000 to \$7FFF)	
EM Area	CV1000-CPU01-E CV2000-CPU01-E	E00000 to E32765 for each bank; 2, 4, or 8 banks (\$8000 to \$8FFD)	EM functions just like DM. An Extended Data Memory Unit must be installed.
Index registers	All	IR0 to IR2	Used for indirect addressing.
Data registers	All	DR0 to DR2	Generally used for indirect addressing.

1-4 Abbreviations

The following abbreviations are used in the messages that appear on the CV Support Software Version 2.

A area	Auxiliary Area	INT	interrupt
AC	action	intr	interrupt
ACN	action	IOIF	I/O Interface Unit
addr	address	ladd	ladder
AQ	action qualifier	lnk	link
bkloop	backloop	MON	monitor
Blk	block	net	network
BIN	binary	offl	offline
BUS	SYSMAC BUS Remote I/O System	onl	online
BUS2	SYSMAC BUS/2 Remote I/O System	onln	online
cht	chart	op	operation
cnd	condition	opt	optical
com	comment	OUT	output
comm	communications	pwr	power
comp	compare	rak	Rack
conf	configuration	rec	reception
conn	connection	RET	return
cont err	non-fatal error (continue error)	reg	register/registration
CPU SIO	CPU Bus Unit	RM	Master
C-ser	C-series	RT	Slave
cum	cumulative	stat	status
disp	display	schl	scheduled
dat	data	sel	select
del	delete	ser	series
dest	destination	spec	specified/special
Dup	duplicated	stop error	stop error (fatal error)
E_UM	Expansion DM and User Program Areas	sht	sheet
edt	edit	SIO	Special I/O Unit
EM	Expansion DM Area	ST	step
EOF	end of file	stan	standard
err	error	SV	set value
ExpRck	Expansion CPU/Expansion I/O Rack	sys	system
FD	floppy disk	swit	switch
FAT	file allocation table	tbl	table
FUN	function code	TN	transition
FV	feedback variable	trans	transition
G area	CPU Bus Link Area	trigg	trigger
HD	hard disk	TRN	transition
IN	input	UM	User Program Memory
ind	indirect	undef	undefined
		WDT	watchdog timer

SECTION 2

SFC Programming

This section provides the procedures required to perform SFC programming. SFC programming is performed using menus and examples of their use are provided. Read the CV-series Operation Manuals and Installation Guide before performing SFC programming.

2-1	Programming Menu	16
2-2	Clearing Memory	17
2-3	Memory Display	19
2-4	Changing SFC Settings	20
2-4-1	Changing Text Input for SFC Parts	20
2-4-2	Changing Display Mode	20
2-4-3	Changing the Number of Displayed Steps	22
2-4-4	Changing the Sheet Size	23
2-5	SFC Programming	24
2-5-1	Entering SFC Parts	26
2-5-2	Inputting SFC Text	27
2-5-3	Inputting Initial Steps	30
2-5-4	Writing a Subchart Dummy Step	31
2-5-5	Deleting SFC Parts	32
2-6	Editing Action Blocks	32
2-6-1	Writing Actions	34
2-6-2	Text Inputs in Action Blocks	36
2-6-3	Inserting and Deleting Actions	38
2-7	Editing Steps and Transitions	38
2-8	Jumping and Searching	44
2-8-1	Jumping the Cursor	44
2-8-2	Finding SFC Parts	44
2-9	Checking SFC Programs	46
2-10	Reading and Writing Sheets	49
2-10-1	Writing Sheets	49
2-10-2	Reading Sheets	51
2-11	Saving and Retrieving Programs	52
2-11-1	Saving Programs	52
2-11-2	Retrieving Programs	53
2-12	Printing SFC Sheets	53
2-12-1	Printing All Sheets	53
2-12-2	Printing the Current Sheet	59
2-13	Overview Mode	59
2-14	Program View Mode	61

2-1 Programming Menu

Select "P:Program" from the main offline menu. The initial (detail view mode) programming screen will be displayed.

Press the End Key or Ctrl+M Keys to display the main programming menu.

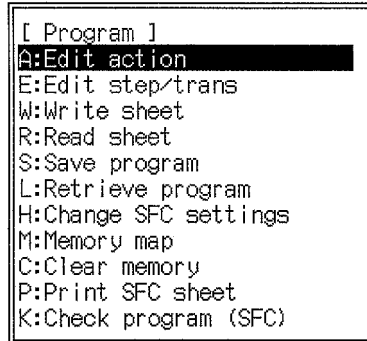

To cancel the programming operation and return to the main offline menu, press the Esc Key or Shift+Esc Keys on the detail view programming screen.

Display Modes

Select the display mode by pressing the F3 or F4 function keys displayed at the bottom of the screen.

It is not possible to switch directly between program view mode and overview mode. First switch to the detail view mode, then to the desired mode.

Screen display mode	Description
Detail view	Basic programming operations. SFC programs can be created and edited in this screen mode.
Overview (F3)	Displays a large-scale view of a large range of the SFC program created or edited in the detail view mode. SFC programs cannot be created or edited in this screen mode.
Program view (F4)	Used for creating and editing action and transition programs. This display mode also permits ladder-diagram program to be written in either ladder form and mnemonic form.

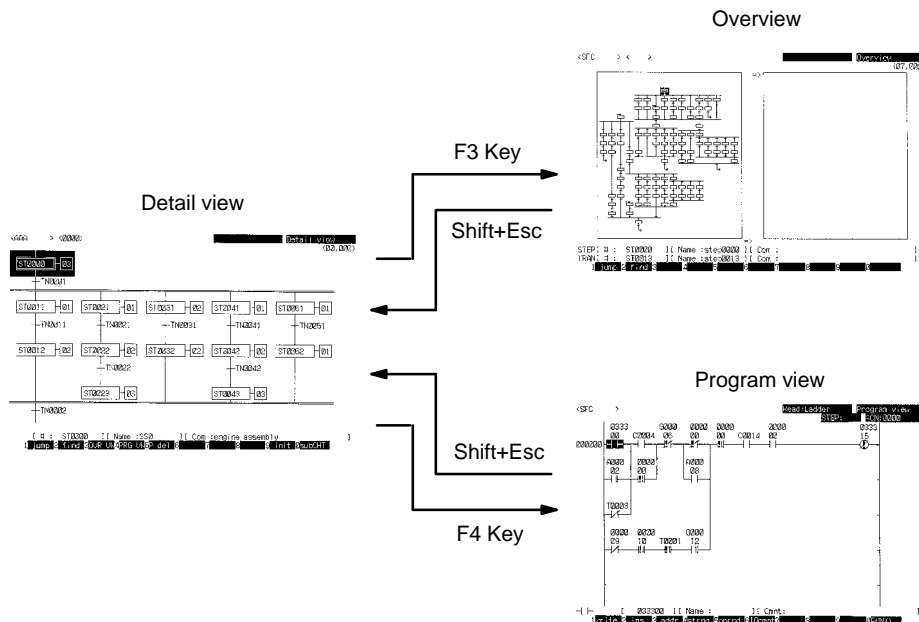

2-2 Clearing Memory

The following operations are used to delete SFC programs, ladder programs (including block comments), I/O names, and I/O comments from the work disk. You can delete only the SFC program or specified sheets.

To start, select "C:Clear memory" from the main programming menu to display the next menu.

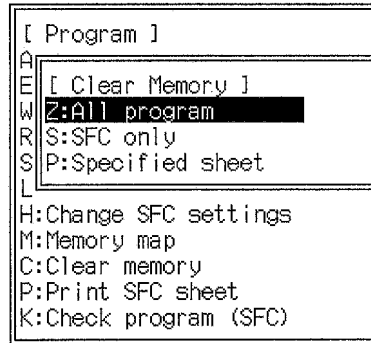

From this menu, select the type of memory clear required.

Memory Clear Menu Operations

Menu Item	Function
All program	Deletes the SFC program, ladder programs (including block comments), I/O names, and I/O comments from the work disk.
SFC only	Deletes the entire SFC program from the work disk. The SFC program is also cleared from the display.
Specified sheet	Deletes the specified sheets of the SFC program from the work disk.

- Use "Z:All program" to clear memory before creating a new program.
- To delete ladder programs only, use the Clear Memory operations in the program view mode.
- To delete I/O names only, use "Edit I/O names" from the main offline menu.
- To delete I/O comments only, use "Edit I/O comments" from the main offline menu.
- Make sure that any required data is saved on a data disk before deleting it from the work disk.

Clearing All Programs

The screen shown below is displayed when "Z:All program" has been selected.

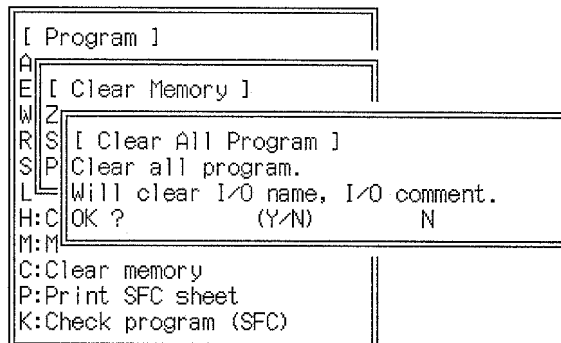

Press the Y and Enter Keys to continue with the memory clear operation. The initial (detail view mode) programming screen will displayed after the memory has been cleared.

or Press the Enter or Esc Key to cancel the memory clear operation.

Clearing SFC Programs

The screen shown below is displayed when “S:SFC only” has been selected.

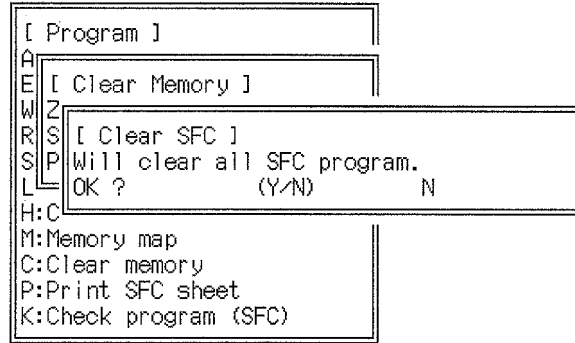

Press the Y and Enter Keys to execute the memory clear operation. The initial (detail view mode) programming screen will be displayed after the memory has been cleared.

or Press the Enter or Esc Key to cancel the memory clear operation.

Clearing a Specified Sheet

The screen shown below is displayed when “P:Specified sheet” has been selected.

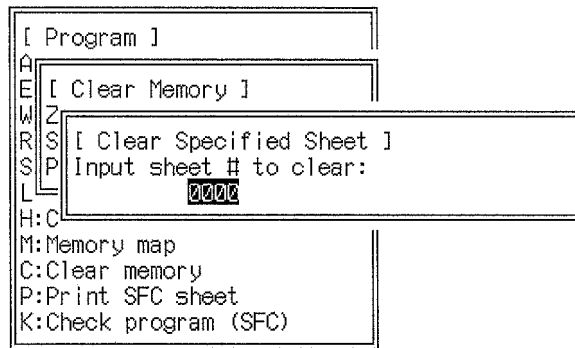

- 1, 2, 3... 1. Enter the number of the sheet to be deleted and press the Enter Key. A confirmation message will appear.
2. Press the Y and Enter Keys to execute the memory clear operation. The initial (detail view mode) programming screen will be displayed after the memory has been cleared.

or Press the Enter or Esc Key to cancel the memory clear operation.

2-3 Memory Display

The following operation displays the status of the user program memory area on the work disk.

Select "M:Memory map" from the main programming menu.

```

[ Program ]
A
E [ Memory Map ]
W PC memory required      Setup :    7,690 wd
R                          SFC  :    476 wd
S                          Ladder :     0 wd
L PC memory left         :    57,370 wd ( 88%)
H
M CUSS memory used      SFC   :    2,071 wd ( 6%)
C                          Ladder :     0 wd ( 0%)
P
K I/O names used         :     0
  I/O comments used     :     0 (    0byte)
  Block comments used   :     0 (    0byte)

```

PC Memory Required

The capacity of PC user memory required to hold the extended PC Setup and all programs if the data currently held in the CVSS work area is transferred to the PC.

PC Memory Left

The amount of PC memory remaining after subtracting the value displayed for "PC memory required."

CVSS Memory Used, SFC

Displays the size of all SFC program sheets on the work disk. I/O names and I/O comments are not included.

The size of all program sheets is also displayed as a percentage of the maximum number of steps, transitions, and actions for the specified model of PC.

The maximum numbers of steps, transitions, and actions for each PC are shown in the following table.

Model	Steps	Transitions	Actions
CV500-CPU01-E	512	512	1024
CV1000-CPU01-E	1024	1024	2048
CV2000-CPU01-E			

CVSS Memory Used, Ladder

Displays the size of all ladder-diagram programs on the work disk both in words and as a percentage of the maximum capacity.

I/O Names Used

Displays the number of I/O names used.

The displayed number is the total of the number used for both ladder-diagram programming and SFC programming. A maximum of 10,000 I/O names is available.

I/O Comment Used

Displays the number of I/O comments used.

The displayed number of used I/O comments is the total of the number used for both ladder-diagram programming and SFC programming. A maximum of 10,000 I/O comments is available.

Block Comment Used

Displays the number of block comments used.

A maximum of 512 block comments is available.

2-4 Changing SFC Settings

2-4-1 Changing Text Input for SFC Parts

This setting specifies whether text is input after each SFC part is created.

- 1, 2, 3... 1. Select "H:Change SFC settings" from the main programming menu. The current settings will be displayed.

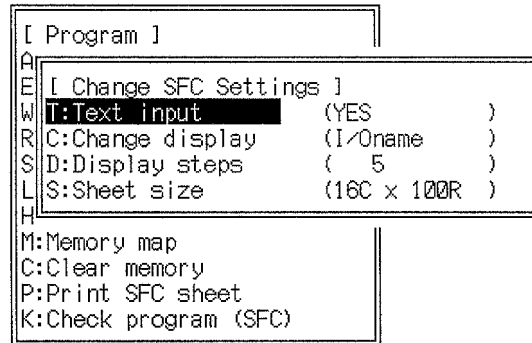

2. Select "T:Text input" from the menu. A message will ask whether text for SFC parts is to be input when the SFC part is written. The following two settings are available:

Y: Input SFC part text (step numbers, etc.) after each SFC part is input.

N: Provisionally display "***" after each SFC part is input, then input the text for SFC parts after all SFC parts have been written.

3. If text is not to be input immediately after each SFC part is written, press the N and Enter Keys. If the text is to be input immediately after each SFC part is written, press the Enter Key, or press the Y and Enter Keys.

The settings will be displayed again.

4. Press the Shift+Esc Keys to return to the main programming menu. The selected text input method will be in effect.

or Press the Esc Key to return to the main programming menu.

2-4-2 Changing Display Mode

This operation is used to control the display of text for SFC parts.

SFC parts can be set to be displayed with I/O names or addresses (bit addresses, step numbers, or transition numbers). This operation sets whether I/O names or addresses are displayed for SFC parts. If an SFC part has only an I/O name or only an address, the name or address will be displayed regardless of this setting.

- 1, 2, 3... 1. Select "H:Change SFC settings" from the main programming menu.

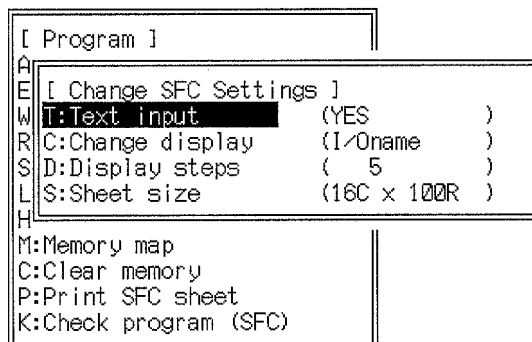

2. Select "C:Change display" from the menu. The current settings will be displayed.



3. Select the desired setting and press the Enter Key. The settings will be displayed again.
 4. Press the Shift+Esc Keys to return to the main programming menu. The selected display mode will be enabled.
- or Press the Esc Key to return to the main programming menu.

Text Display Modes

I/O Names

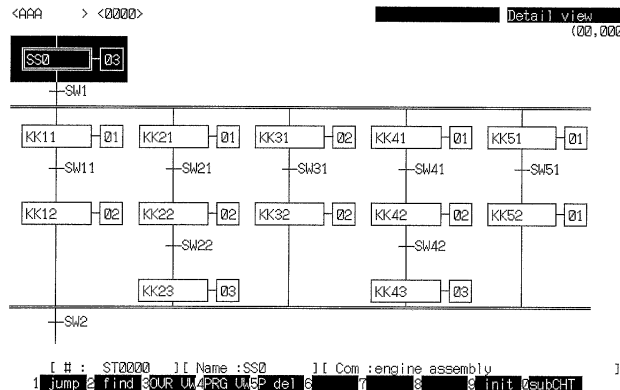

Addresses

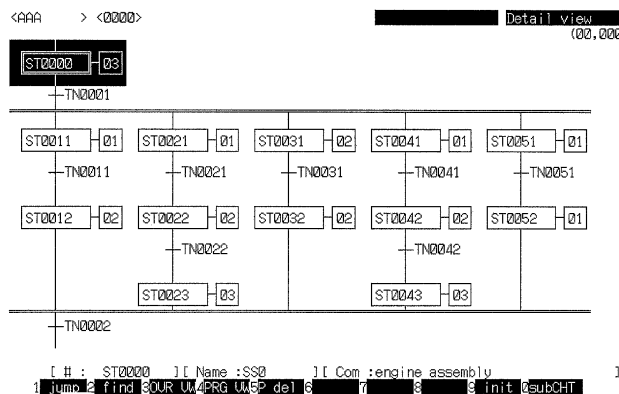

Transition numbers will be displayed in parentheses if the transition is defined using an input bit. The address, I/O name, and I/O comment for the SFC part at the current cursor position are displayed in the SFC text line at the bottom of the display.

2-4-3 Changing the Number of Displayed Steps

This operation is used to set the number of columns of SFC parts displayed. The initial setting of the displayed steps is 5. As the number of displayed steps increases, the number of text characters displayed decreases.

- 1, 2, 3... 1. Select "H:Change SFC settings" from the main programming menu.

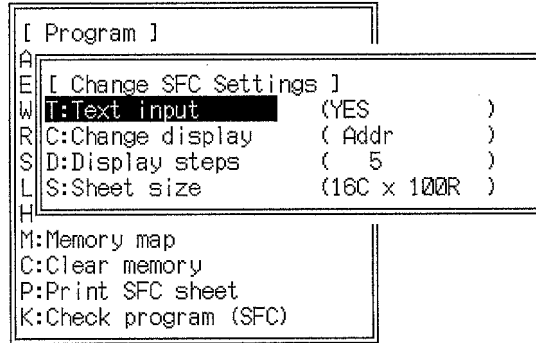

2. Select "D:Display steps" from the menu. The possible settings of the number of SFC steps will be displayed.

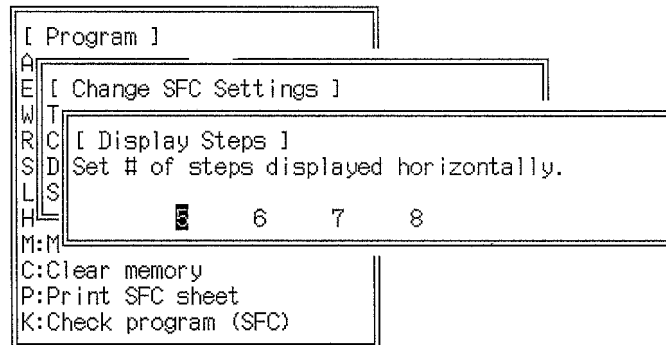

3. Press the Left and Right Keys to select the required number of SFC columns and press the Enter Key. The settings will be displayed again.
 4. Press the Shift+Esc Keys to return to the main programming menu. The selected number of columns will be displayed.
 or Press the Esc Key to return to the main programming menu.

Displayed Step Settings

Displayed Steps = 5

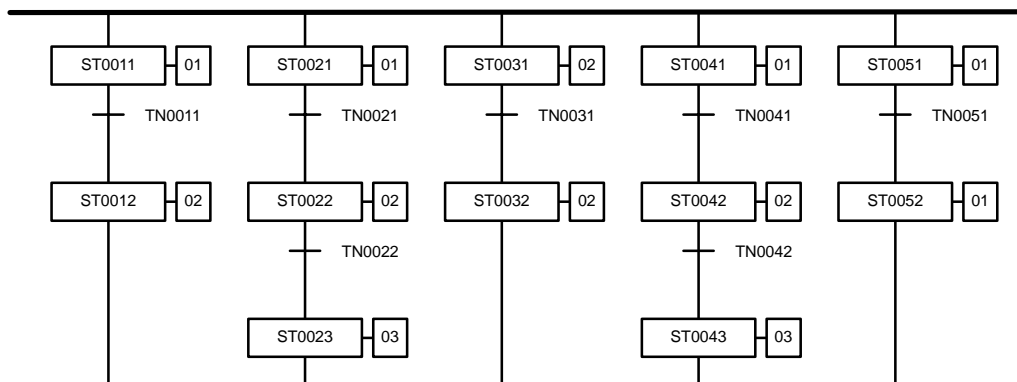

Displayed Steps = 8

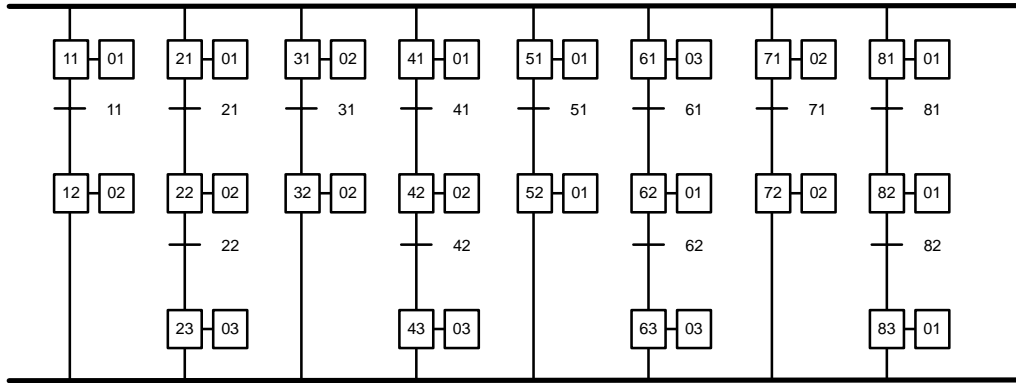

2-4-4 Changing the Sheet Size

This operation is used to set the sheet size for creating SFC programs. The sheet size can be changed as long as the number of SFC parts does not already exceed 8 columns or 100 rows (lines). A warning message will be displayed in the top-left corner of the screen if an attempt is made to change the sheet size when the number of SFC parts exceeds 9 columns or 101 rows.

- 1, 2, 3... 1. Select "H:Change SFC settings" from the main programming menu. The current settings will be displayed.

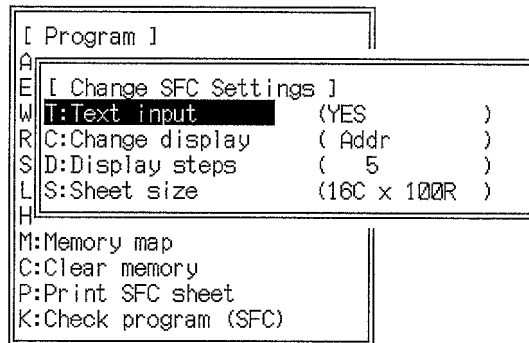

2. Select "S:Sheet size" from the menu. The possible sheet size settings will be displayed.

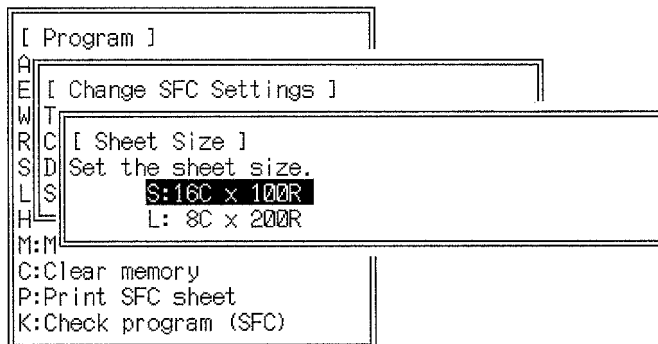

3. Select the required sheet size. The new settings will be displayed.
 4. Press the Shift+Esc Keys to return to the main programming menu. The selected sheet size will be enabled but the screen display does not change.
- or Press the Esc Key to return to the main programming menu.

2-5 SFC Programming

This section describes how to create an SFC program.

Preparations

The default settings for the screen are shown in the table below. Follow the procedures described in the previous section to change the default settings, if required.

Item	Setting
Text input	Yes
Text display	I/O name
Number of columns of steps	5
Sheet size	16 columns * 100 rows (lines)

Delete all existing SFC programs before creating a new program (see 2-2 *Clearing Memory*). The existing program will be overwritten if the sheet currently being edited is not cleared.

SFC Programming Screen

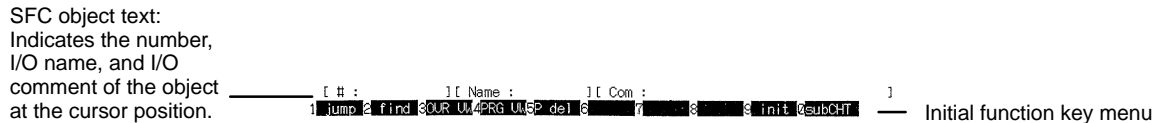
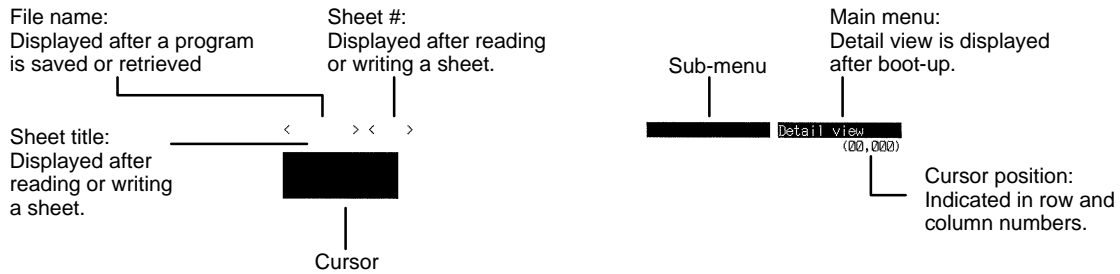

The main menu and sub-menus are displayed in the top-right corner of the screen. The function key menu is displayed at the bottom of the screen. The displayed menu items correspond to the function keys F1 to F10. There are three sets of function key operations available: those normally shown, those shown when the Shift Key is held down, and those shown after the F10 Key is pressed with the Shift Key held down.

Moving the Cursor

The Arrow Keys

The cursor can be moved within the currently specified sheet size.

Press the Up and Down Keys to move the cursor up and down between the top and bottom of the sheet. Press the Left and Right Keys to move the cursor left and right between the left and right edges of the sheet.

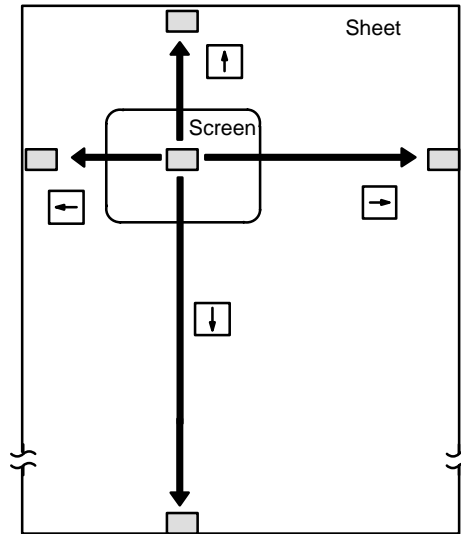

The PgDn and PgUp Keys

Press the PgDn Key to move the display down the sheet to display the lines previously below the screen. The cursor position on the screen does not normally change. However, when the end of the sheet is reached, the cursor will move to the bottom of the screen.

Press the PgUp Key to move the display up the sheet, to display the lines previously above the screen. The cursor position on the screen does not normally change. However, when the top of the sheet is reached, the cursor will move to the top of the screen.

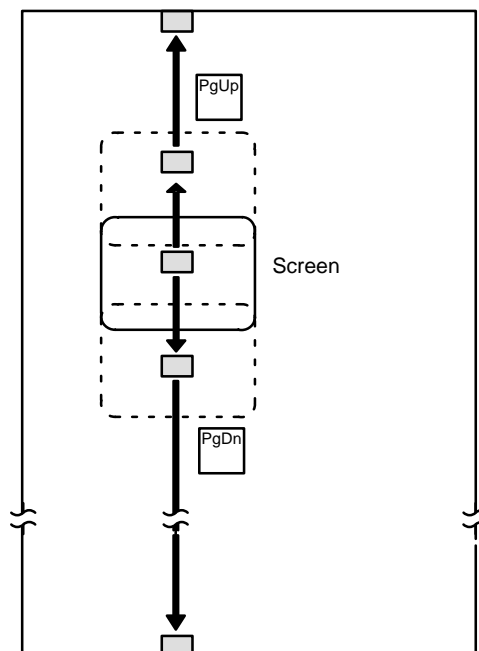

2-5-1 Entering SFC Parts

Do not exceed 100 steps or transitions on any single sheet.

- 1, 2, 3... 1. Move the cursor to the position where the SFC part is to be input. The position where a part can be input depends on the type of SFC part. Refer to the table below.
2. Input the SFC part with the function keys. The input part will be displayed at the cursor position.



```
[ # : ] [ Name : ] [ Com : ]
1: jump 2 find SOUR UM4PRG UM5P del 8 7 8 9 init 0subCHT 1
```

3. Press the Enter Key to enter the displayed SFC part.
4. When immediate text input is turned ON, a message will be displayed prompting for text input after each SFC part is entered. Enter the SFC part text.

SFC Part Locations

Conditional branching and joining, parallel branching and joining, and SFC jumps and jump entries can be written in combination with other SFC parts as shown in the following table.

SFC part		Allowed position	Function keys		
Name	Symbol				
Step		Odd-numbered line	SHIFT+F1		
SFC jump SFC jump entry			SHIFT+F6		
Power OFF interrupt entry terminal			Holding down the Shift Key, press the F10 Key followed by the key shown at the right.	F1	
Power OFF interrupt return terminal				F2	
Power ON interrupt entry terminal				F3	
Power ON interrupt return terminal				F4	
Scheduled interrupt entry terminal				F5	
Scheduled interrupt return terminal				F6	
I/O interrupt entry terminal				F7	

Name	Symbol		
I/O interrupt return terminal		Odd-numbered line	Holding down the Shift Key, press the F10 Key followed by the key shown at the right. F8
Transition		Even-numbered line	SHIFT+F2
Subchart entry terminal			SHIFT+F7
Subchart return terminal			SHIFT+F8
Conditional branch/join		No restriction	SHIFT+F3
Parallel branch/join			SHIFT+F4
Vertical connection			SHIFT+F5

2-5-2 Inputting SFC Text

SFC text provides the I/O name or address assigned to an SFC part during SFC programming.

To input or change the text for an existing SFC part, move the cursor to the part and press the Enter Key.

The function key menu at the bottom of the screen will change and the input area will appear above the function key menu. (The screen automatically switches to this status after each SFC part is written if immediate text input is turned ON.)

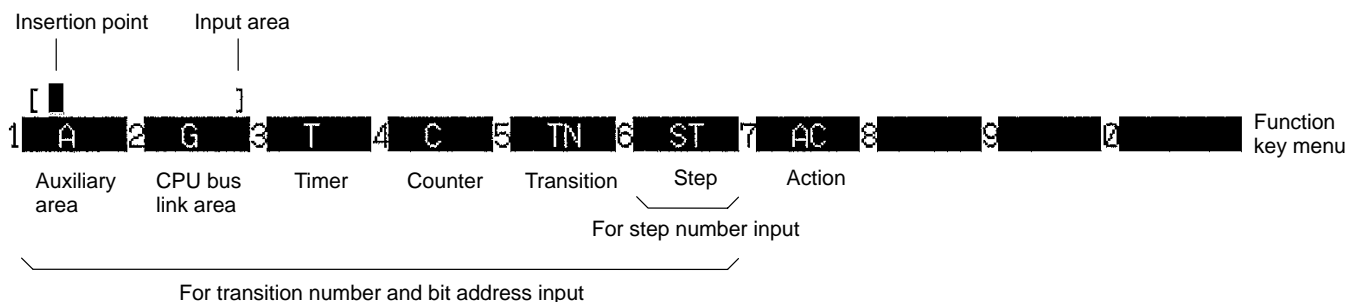

If text already exists at the cursor position, it will be displayed in the input area.



Inputting Text for SFC Parts

CR indicates the Enter Key.

SFC part		Key sequence	Comments
Name	Symbol		
Step		F6 step number CR or I/O name CR	Step numbers CV500: 0 to 511 CV1000: 0 to 1023 The I/O name may be input instead of the step number. Do not press the F6 Key if the I/O name is input.
Transition		To use a transition number: F5 transition no. CR or I/O name CR	Transition numbers CV500: 0 to 511 CV1000: 0 to 1023 The I/O name may be input instead of the transition number. Do not press the F5 Key if the I/O name is input.

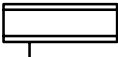
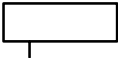
SFC part		Key sequence	Comments																		
Name	Symbol																				
Transition		To use a bit address: F5 <i>transition no.</i> Shift+Right Arrow <i>bit address (or I/O name)</i> CR	When inputting a bit address for a transition, specify the data or memory area of the bit using capital prefix, or using the function keys as shown below. <table border="1"> <thead> <tr> <th>Prefix</th> <th>Function key</th> <th>Area</th> </tr> </thead> <tbody> <tr> <td>A</td> <td>F1</td> <td>Auxiliary Area</td> </tr> <tr> <td>G</td> <td>F2</td> <td>CPU Bus Link Area</td> </tr> <tr> <td>T</td> <td>F3</td> <td>Timer Area</td> </tr> <tr> <td>C</td> <td>F4</td> <td>Counter Area</td> </tr> <tr> <td>ST</td> <td>F6</td> <td>Step Area</td> </tr> </tbody> </table>	Prefix	Function key	Area	A	F1	Auxiliary Area	G	F2	CPU Bus Link Area	T	F3	Timer Area	C	F4	Counter Area	ST	F6	Step Area
Prefix	Function key	Area																			
A	F1	Auxiliary Area																			
G	F2	CPU Bus Link Area																			
T	F3	Timer Area																			
C	F4	Counter Area																			
ST	F6	Step Area																			
SFC jump		F6 <i>step number</i> CR	Input the step number of the SFC jump destination.																		
Scheduled interrupt entry terminal		<i>interrupt number</i> CR	Interrupt numbers: 0, 1																		
I/O interrupt entry terminal		<i>interrupt number</i> CR	Interrupt numbers: 00 through 31																		

- Note**
1. It is not necessary to input leading zeros for step numbers, transition numbers, timer numbers, or counter numbers. However, leading zeros are required for bit addresses and interrupt numbers.
 2. Press the Backspace Key to delete erroneous entries, then re-enter the number.

Inputting Step Numbers

Press the F6 Key to display ST on the screen, input the required step number, and press the Enter Key. To input a different step number or I/O name from that currently displayed in the input area, press the Backspace Key to delete the current entry, and input the required step number or I/O name before press the Enter Key.

An I/O name can be input instead of the step number, provided the I/O name has been allocated using the Edit I/O name operation. Do not press the F6 Key when entering I/O names.

Press the Esc Key or Shift+Esc Keys to cancel the input. The previously entered text will be cleared and asterisks (****) will be displayed.

Inputting Transition Numbers A transition number or bit address must be set for each transition. If a bit address is to be set, the transition number must be set before the bit address can be input. If a transition number is set without a bit address, a transition program containing a TOUT (202) or TCNT (123) instruction must be written in the program view mode after the SFC has been input.

An I/O name can be input instead of the bit address or transition number, provided the I/O name has been allocated using the Edit I/O name operation. Do not press the F1 to F6 Keys when using an I/O name.

- 1, 2, 3...**
1. Move the cursor to the required transition and press the Enter Key. The function key menu at the bottom of the screen will change, and the transition and bit address input areas will appear above the function key menu. (The

screen will automatically switch to this status after each transition is written if the immediate text input is turned ON in the SFC settings.

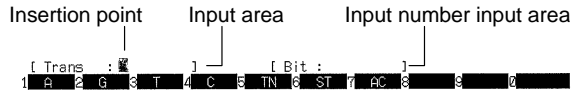

2. Press the Enter Key to input the transition number or bit address currently displayed in the input area.
- or To input a different transition number or bit address from that currently displayed in the input area, press the Backspace Key to delete the current entry, input the required text, and press the Enter Key.
- or Press the Esc Key or Shift+Esc Keys to cancel the input of the text for SFC parts. The previously entered text will be cleared and asterisks (****) will be displayed for the transition.

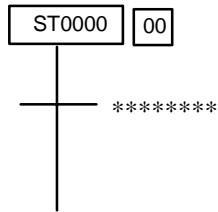

After the cursor has been moved to the bit address input area by pressing the Shift and Right Keys, it can be returned to the transition number by pressing the Shift and Left Keys.

Inputting Interrupt Numbers

1, 2, 3...

1. Move the cursor to the required scheduled interrupt entry terminal or I/O interrupt entry terminal and press the Enter Key. The interrupt number input area will appear above the function key menu at the bottom of the screen.



An initial value of 0 or 00 will be displayed before a new interrupt number is input. If a scheduled interrupt entry terminal or I/O interrupt entry terminal exists at the cursor position, this interrupt number will be displayed in the interrupt number input area.

2. Press the Enter Key to input the interrupt number currently displayed in the input area. To input a different interrupt number from that currently displayed in the input area, press the Backspace or Home Key to delete the current entry, input the required interrupt number, and press the Enter Key.

The interrupt number for a scheduled interrupt entry terminal must be input as 0 or 1.

The interrupt number for an I/O interrupt entry terminal must be input in the range 0 to 31.

A message will be displayed in the top-left corner of the screen to inform the operator if the input interrupt number exceeds the ranges listed above.

- or Press the Esc Key or Shift+Esc Keys to cancel the interrupt number input. The previously entered number will be cleared and asterisks (**) will be displayed for the scheduled interrupt entry terminal or I/O interrupt entry terminal.

Inputting SFC Jumps

- 1, 2, 3...
 1. Move the cursor to the jump source position. The jump source must be just after a transition.
 2. Press the Shift+F6 and Enter Keys to insert a jump at the cursor position.
 3. Press the F6 key, enter the step number of the jump destination, and press the Enter Key. An I/O name can be input instead of the step number. In this case, do not press the F6 function key. The jump destination is written to the right of the jump.
 4. Move the cursor to the jump destination step and press the Shift+F6 and Enter Keys to insert the jump entry.

2-5-3 Inputting Initial Steps

Input an initial step by first inputting a normal step and then changing it to an initial step. It is not possible to input an initial step directly.

- 1, 2, 3...
 1. Move the cursor to the required step.



2. Press the F9 Key to change the selected step to an initial step. Each time the F9 Key is pressed, the designated step will toggle between a normal step and an initial step.



2-5-4 Writing a Subchart Dummy Step

- 1, 2, 3... 1. Press the F10 Key to display a subchart dummy step at the cursor position.



```
[ # :      ] [ Name :      ] [ Com :      ]
1 jump 2 find 3 OUR UM4PRG UM3P del 6 7 8 9 init 0 subCHT ]
```

2. Press the Enter Key to insert the displayed subchart dummy step. A subchart dummy step can be inserted only at even-numbered line.

Inputting the Subchart Dummy Step Text

After the subchart dummy step has been written, the subchart dummy step text input area and the subchart entry step input area will appear above the function key menu at the bottom of the screen.

The text input for a subchart dummy step comprises of two parts:

- The step number or I/O name of the subchart dummy step itself and
- The step number or I/O name of the subchart entry step called by the subchart dummy step.



```
Step number          Sub-chart entry
input number         step input area
Insertion point
Step [ 1 ]          Subchart entry [ 2 ]
1 A 2 G 3 T 4 C 5 TN 6 ST 7 AC 8 9 0
```

- 1, 2, 3... 1. If a subchart dummy step already exists at the cursor position, press the Enter Key to display the subchart dummy step text in the input area.
2. Enter a step number or I/O name for the subchart dummy step and press the Enter Key.
- The cursor will move to the subchart input area.
3. Enter a step number or I/O name for the subchart entry step and press the Enter Key.
- or Press the Esc Key or Shift+Esc Keys to cancel the input of the subchart dummy step text or the subchart entry step text. Text entries cancelled during input will not be written. However, if the Esc Key or Shift+Esc Keys is pressed during input of the subchart entry step number or I/O name, the previously entered subchart dummy step text will be written.

2-5-5 Deleting SFC Parts

This operation is used to delete individual SFC parts displayed on the screen. Use the delete operation under “Edit step/trans” on the main programming menu to clear blocks of SFC parts (see 2-7 *Editing Steps and Transitions*).

- 1, 2, 3... 1. Move the cursor to the SFC part to be deleted.
2. Press the F5 Key. A message at the bottom of the screen instructs the operator to select the SFC part to be deleted.
3. Depending on the type of SFC part to be deleted, press the following keys: Shift+F1 to F8, Shift+F10, F9, or F10.
4. Press the Enter Key to delete the selected SFC part.

Examples

Deleting a Step

In the following example, only the step is deleted when a step and conditional connection are selected by the cursor.



Press F5, the Shift+F1, and then the Enter Key.



Deleting a Conditional Branch

In the example, only the conditional branch is deleted when a step and conditional connection are selected by the cursor.



Press F5, the Shift+F3, and then the Enter Key.



2-6 Editing Action Blocks

- 1, 2, 3... 1. Select “A:Edit action” from the main programming menu.
2. Move the cursor to the step whose action block is to be edited and press the Enter Key. The function key menu will change and the action block will be displayed at the right of the screen. The AQ (action qualifier), SV (set value), action, and FV (feedback variable) can be entered in the spaces marked by asterisks (***).

The Shift+Right Keys may be pressed instead of the Enter Key to display the action block. When the action block is displayed, the Shift+Left Keys may be pressed to return to the step display.

Action Blocks

Up to 15 actions can be contained in a single step. Up to eight of these actions can be displayed at once. The number of actions in each step is displayed in the box to the right of the step. Each sheet can contain up to 1,500 actions.

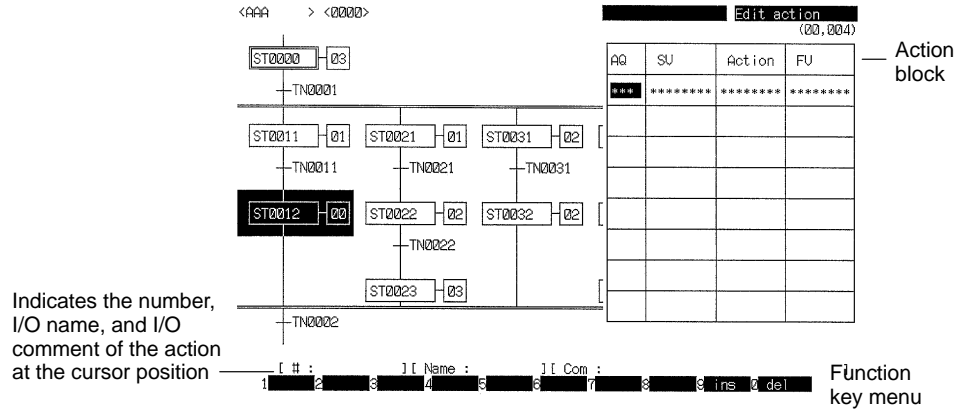

- Press the Shift+Esc Key to return to the programming screen.
- or Press the Esc Key to return to the step display.

Moving the Cursor

The way the cursor is moved depends on the number of actions. The cursor can be moved to the line immediately below the lowest action.

- Press the Up and Down Keys to move the cursor up and down between the highest action and the line immediately below the lowest action.
- Press the Left and Right Keys to move the cursor left and right between the AQ and FV columns.

AQ	SV	Action	FV
***	*****	*****	*****
***	*****	*****	*****
***	*****	*****	*****
***	*****	*****	*****
***	*****	*****	*****
***	*****	*****	*****
***	*****	*****	*****

- Press the PgUp or PgDn Key to scroll between the two pages of the action block.

The top line of the second page of the action block displays the same action as the bottom line of the first page. Press the Up and Down Keys to move the cursor up and down between the highest action and the line immediately below the lowest action.

2-6-1 Writing Actions

The AQ, SV, action, and FV can only be entered in the spaces marked by asterisks (****). It is not possible to enter data in blank spaces. Move the cursor to a blank line and press the F9 key to display asterisks in the spaces to permit data to be written. The cursor can only be moved to the top blank line.

Writing AQ

- 1, 2, 3... 1. Move the cursor to the AQ column where the asterisks (****) are displayed and press the Enter Key. The AQ table will be displayed at the left of the screen.

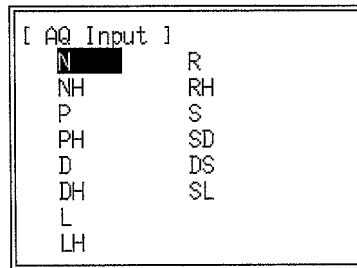

2. Select the required AQ with the cursor and press the Enter Key. The AQ table will disappear and the selected AQ will be displayed at the cursor position. The cursor will move to the SV column.
- or Press the Esc Key or Shift+Esc Keys to cancel the AQ input. This hides the AQ table and locks the cursor in the action block.

Writing SV

An SV must be input when one of the following AQ is written: D, DH, L, LH, SD, DS, SL The SV can be specified as a constant or a word. The setting ranges are defined below.

Constant: 0000 to 9999 (default unit: 0.1 s)

Word: Contents of word must be between 0000 and 7FFD (0 to 32765)

The using for setting the SV can be changed to 1 s using the Step Timer setting in the PC Setup. The relationships between the AQ operations and the SVs are shown following the display below.

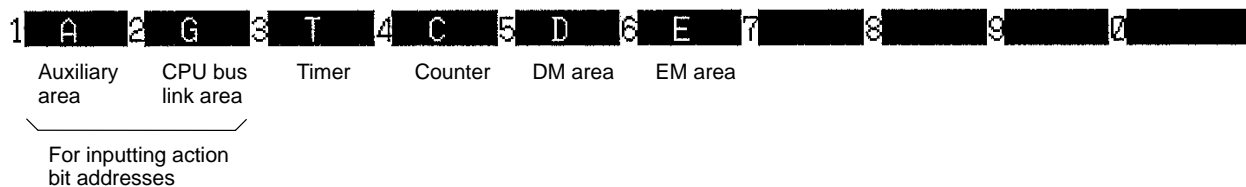
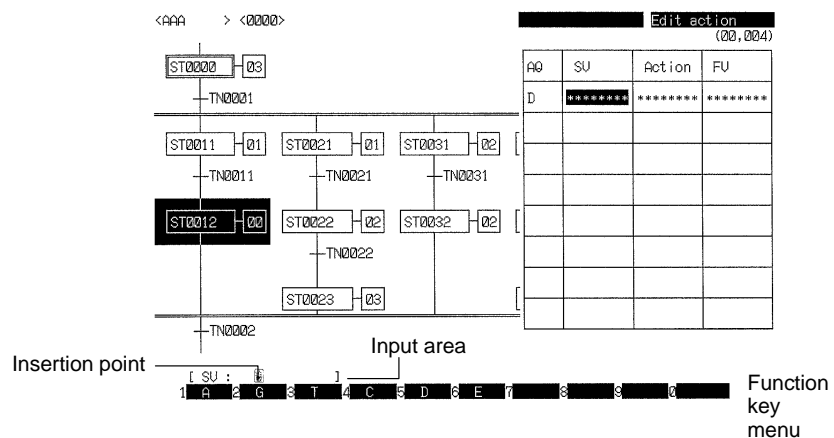

Execution Time

Action qualifiers with the hold option (NH, PH, DH, LH, or RH) are not reset after the action changes from active to non-active status and thus remain ON. Use RH if a hold is required with the S, SL, SD, and DS action qualifiers.

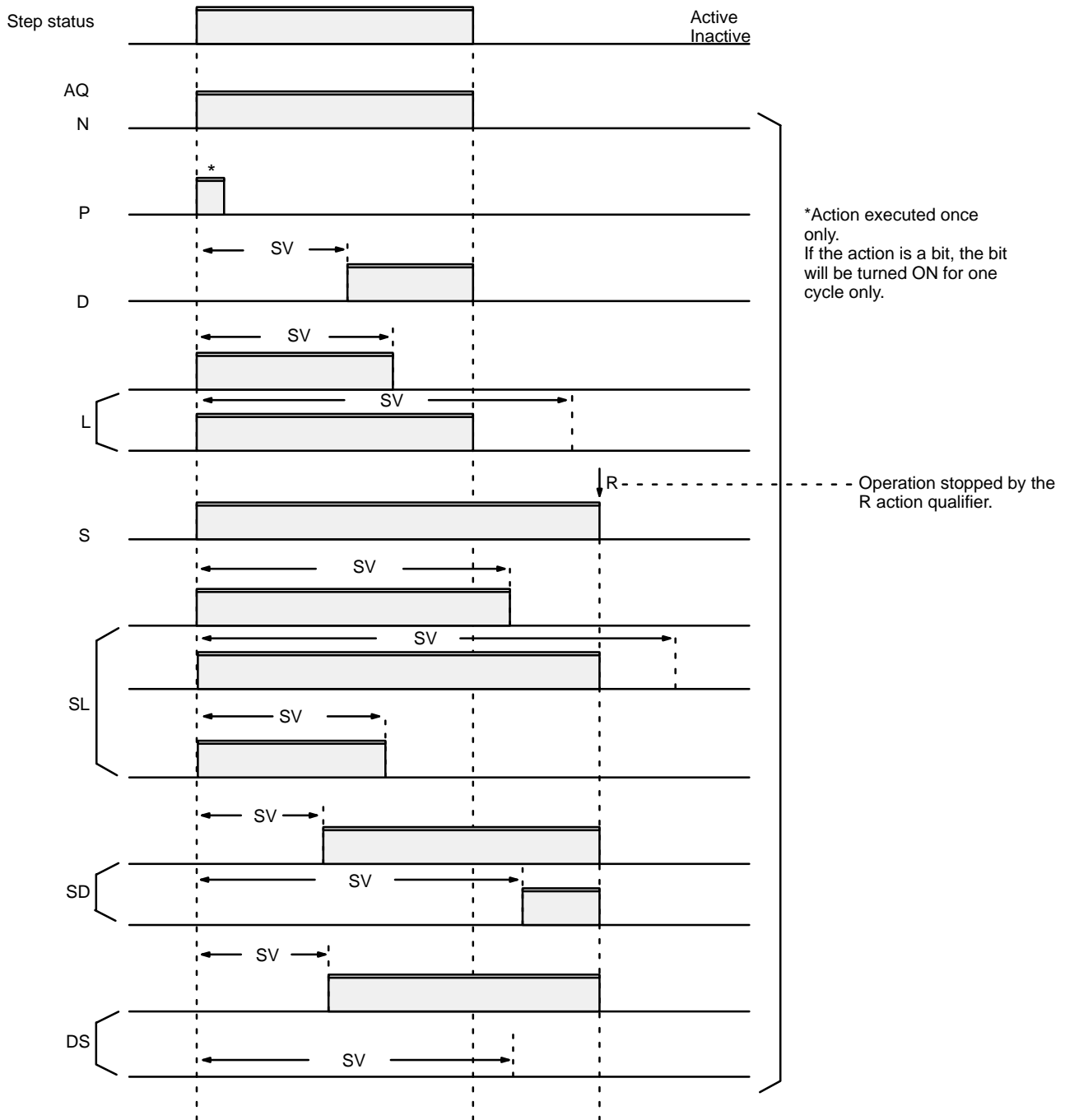

Writing Actions and FV

- 1, 2, 3... 1. Move the cursor to the position where the action or FV is to be written and press the Enter Key. The function key menu will change and the input area will appear above it. If an action number, bit address, word address, or I/O

name already exists at the cursor location, it will be displayed in the input area. The screen will appear as shown below.

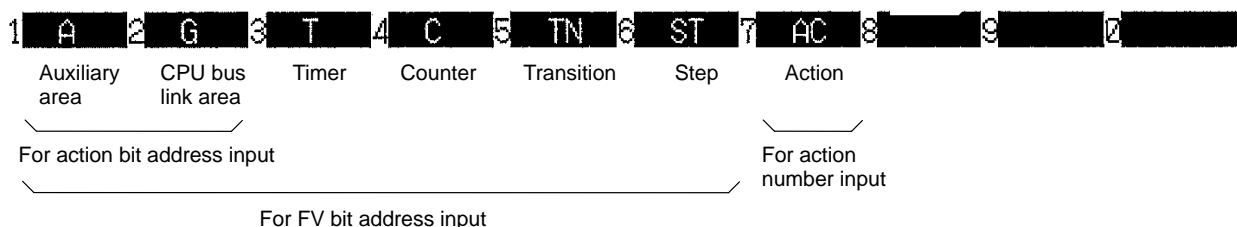
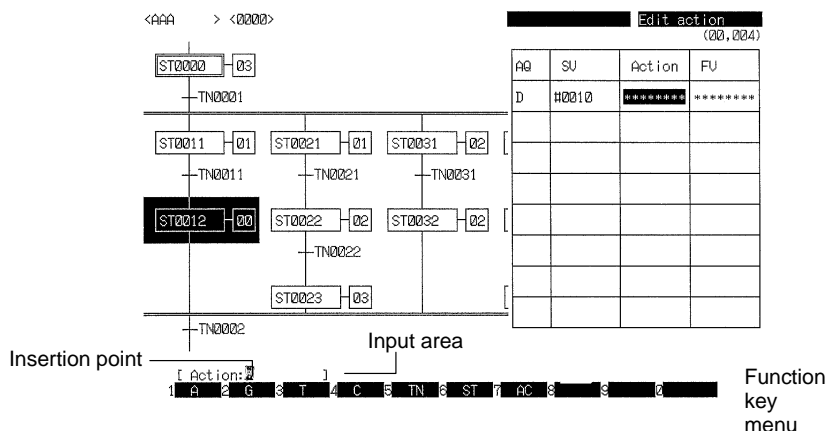

2. Input the action number, bit address, word address, or I/O name according to the key able which follows this procedure.
3. Press the Enter Key. The input action number, bit address, word address, or I/O name will be written to the cursor position in the action block and the cursor will move one space to the right, or if the Enter Key is pressed when the cursor is in the FV column, asterisks (****) will be displayed in the line below and the cursor will move to the AQ column.
A message will appear in the top-left corner of the screen to warn the operator if an action number, bit address, or word address is input out of range.
- or Press the End or Esc Key to cancel writing the action and FV. The entered action number, bit address, word address, or I/O name will not be written.
4. Press the PgDn Key to display the second pages of the action block if 8 or more action numbers are displayed.

2-6-2 Text Inputs in Action Blocks

The following table provides the key sequences for inputting text into the SV, action, and FV columns of action blocks. Capital letters may be input instead of pressing the corresponding function key to designate prefixes. Example: **F7** may be input as **Shift+A**, **Shift+C** for the Action Area. **CR** indicates the Enter Key.

Data area	SV key combination	Action key combination	FV key combination	Display
Action Area	—	F7 <i>action number</i> CR	—	AC
Auxiliary Area	F1 <i>word address</i> CR	F1 <i>bit address</i>	F1 <i>bit address</i> CR	A
CIO Area	<i>word address</i> CR	<i>bit address</i> CR	<i>bit address</i> CR	—
Constant	SHIFT+3 <i>set value</i> CR	—	—	#
Counter Area	F4 <i>counter number</i> CR	—	F4 <i>counter number</i> CR	C
CPU Bus Link Area	F2 <i>word address</i> CR	F2 <i>bit address</i>	F2 <i>bit address</i> CR	G

Data area	SV key combination	Action key combination	FV key combination	Display
DM Area	F5 DM address CR	—	—	D
EM Area	F6 EM address CR	—	—	E
I/O name	<i>I/O name CR</i>	<i>I/O name CR</i>	<i>I/O name CR</i>	—
Step Area	—	—	F6 step number CR	ST
Timer Area	F3 timer number CR	—	F3 timer number CR	T
Transition Area	—	—	F5 transition number CR	TN

- Note**
1. SFC text requiring leading zeros are marked “Yes” in the following table.
 2. Press the Backspace Key to delete mistakes, then re-enter the number.

Text Requiring Leading Zeros

Yes: Leading zeros required
No: Leading zeros not required

Number/Address	SV	Action	FV
Action Area	Not applicable	No	Not applicable
Auxiliary Area	No	Yes	Yes
CIO Area	No	Yes	Yes
Constants	No	Not applicable	Not applicable
Counter Area	No	Not applicable	No
CPU Bus Link Area	No	Yes	Yes
DM Area	No	Not applicable	Not applicable
EM Area	No	Not applicable	Not applicable
Step Area	Not applicable	Not applicable	No
Timer Area	No	Not applicable	No
Transition Area	Not applicable	Not applicable	No

2-6-3 Inserting and Deleting Actions

The following table shows how to insert or delete actions in an action block.

Method

Operation	Key sequence	Description
Insert	<i>cursor setting</i> F9	Inserts an action at the cursor position if the cursor is at a blank position. No more than 16 actions can be inserted in an action block. A message will warn the operator if an attempt is made to insert more than 16 actions.
Delete	<i>cursor setting</i> F10 CR	Deletes the action at the cursor position. No action can be deleted if the cursor is at a blank position. When the F10 Key is pressed, a confirmation message will appear at the bottom of the screen. Press the Enter Key, or Y and Enter Keys to delete the selected action. Press the N and Enter Keys to cancel the delete operation and leave the action unchanged.

Insert

Action block

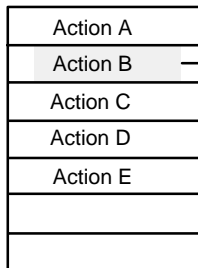

Action block

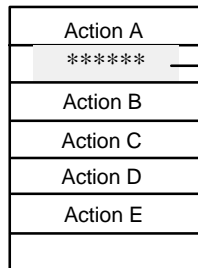

Delete

Action block

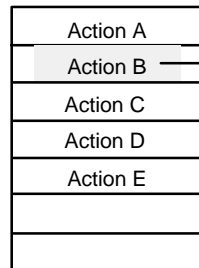

Action block

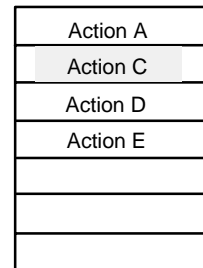

2-7 Editing Steps and Transitions

This section describes the operations required to insert, copy, delete, and move SFC parts in an SFC program.

Steps and transitions can be edited for all SFC parts. The copy, delete, and move operations are effective for all SFC parts selected with the cursor. Follow the procedure in 2-5-5 *Deleting SFC Parts* to delete specified parts inside the cursor.

Actions and transitions are inserted or deleted in pairs, so that the number of inserts or deletes must always be specified as an even number of lines.

- 1, 2, 3... 1. Press the End Key or Ctrl+M Keys to display the main programming menu.
2. Select "E:Edit step/trans from the menu.

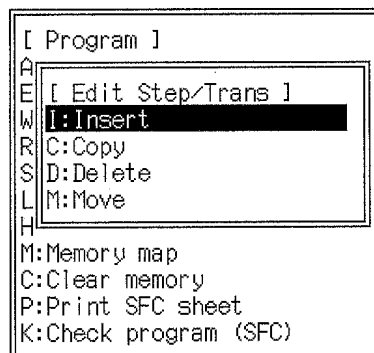

3. Select the required operation, as outlined in the following table.

- When the operation has been completed, press the Shift+Esc Keys to return to the main offline menu, or press the Esc Key to return to the main programming menu.

Step and Transition Editing Operations

Name	Description	Function
Insert line		<p>Inserts the specified number of blank lines at the cursor</p>
Insert column		<p>Inserts the specified number of blank columns at the cursor.</p>
Copy		<p>Copies multiple SFC parts specified by the cursor.</p>
Delete line		<p>Deletes the specified number of lines from the specified position. Take care when specifying the lines, as lines off the screen can also be deleted.</p>
Delete column		<p>Deletes the specified number of columns from the designated position. Take care when specifying the columns, as columns off the screen can also be deleted.</p>
Delete selection		<p>Deletes multiple SFC parts specified with the cursor.</p>
Move		<p>Moves multiple SFC parts specified with the cursor.</p>

Inserting Line

- 1, 2, 3... 1. Select "I:Insert" from the menu.

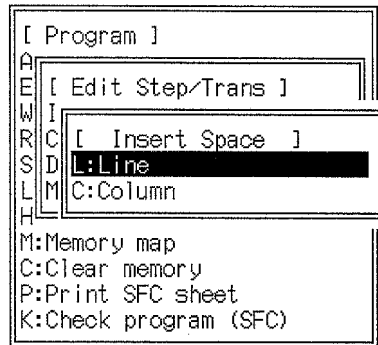

2. Select "L:Line" from the menu. The following display will appear and an initial value of 002 will be displayed for the number of lines to insert.

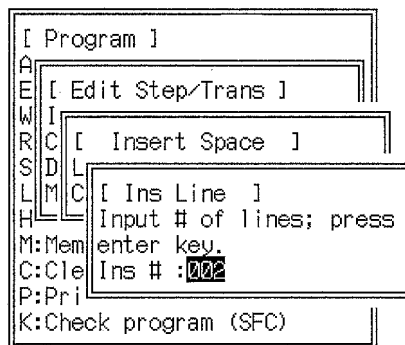

3. Enter the required number of lines and press the Enter Key. Always set the number of lines to an even number no less than 2.
4. Move the cursor to the insertion point and press the Enter Key. A message at the top-left of the screen will warn the operator if the inserted lines exceed the current sheet size. In this case, re-position the cursor to the correct insertion position and press the Enter Key.

Any SFC parts connected horizontally before the lines are inserted will remain connected after the insertion.

Inserting Columns

- 1, 2, 3... 1. Select "I:Insert" from the menu.
2. Select "C:Column" from the menu. The following display will appear and an initial value of 01 will be displayed for the number of columns to insert.

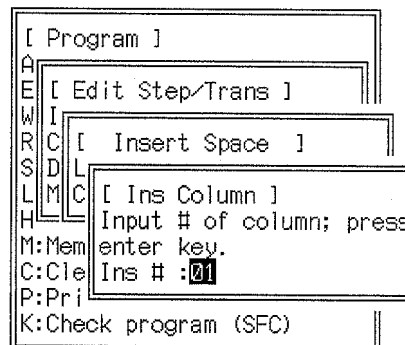

3. Enter the required number of columns and press the Enter Key. Set the number of columns to any number no less than 1.

4. Move the cursor to the insertion point and press the Enter Key. A message at the top-left of the screen will warn the operator if the inserted columns exceed the current sheet size. In this case, re-position the cursor to the correct insertion position and press the Enter Key.

Any SFC parts connected horizontally before the columns are inserted will remain connected after the insertion.

The jump operation (F1 Key) or search operation (F2 Key) can also be used to position the cursor for an insert, copy, delete, or move operation (see 2-8 *Jumping and Searching*). After moving the cursor with the jump or search operation, press the Enter Key to specify the position for the insert, copy, delete, or move operation.

Copying

- 1, 2, 3...
 1. Select "E:Edit step/trans" from the main programming menu.
 2. Select "C:Copy" from the Edit step/trans menu.
 3. Move the cursor to the start point of the range to be copied and press the Enter Key.
 4. Move the cursor to the end point of the range to be copied and press the Enter Key. Specify the end point to the right of or below the start point. The range specified between the start and end points will be display in reverse video on the screen.

Press the Esc Key or Shift+Esc Keys to deselect the range to be copied and revert to the programming screen.

5. Move the cursor to the copy destination and press the Enter Key. Specify a copy destination outside the selected copy range.

If the start point of the copy range is an even line number, specify an even-numbered line as the copy destination. If the start point of the copy range is an odd line number, specify an odd-numbered line as the copy destination.

The specified range will be copied to the destination and the display will revert to the programming screen.

Note Parts at the copy destination are overwritten.

The line and column numbers are displayed in the top-right corner of the screen. Both lines and columns are numbered from zero.

Deleting Lines

Note Take care when specifying lines to delete as it is possible to delete lines not displayed on the screen.

- 1, 2, 3...
 1. Select "E:Edit step/trans" from the main programming menu.
 2. Select "D:Delete" from the Edit step/trans menu.

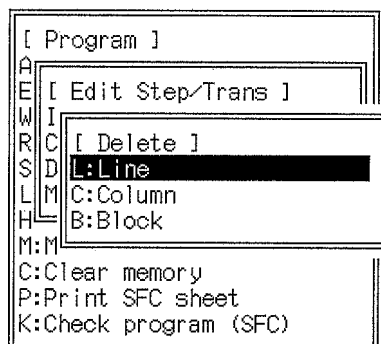

3. Select "L:Line" from the Delete menu.

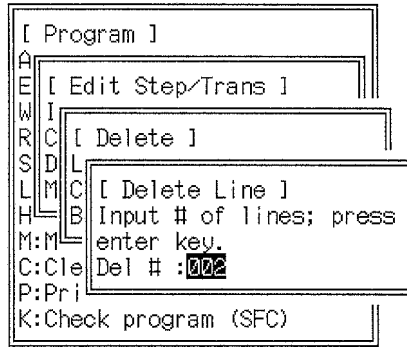

From this point, follow the procedure described for inserting lines given above.

Deleting Columns

Note Take care when specifying columns to delete as it is possible to delete columns not displayed on the screen.

- 1, 2, 3...
1. Select "E:Edit step/trans" from the main programming menu.
 2. Select "D:Delete" from the Edit step/trans menu.
 3. Select "C:Column" from the Delete menu.

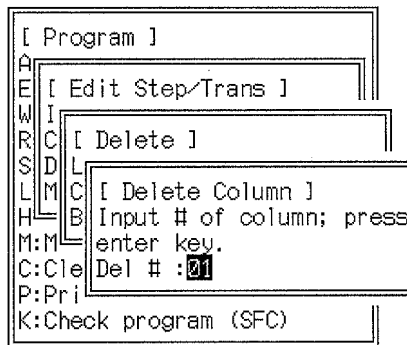

From this point, follow the procedure described for inserting columns toward the beginning of this section.

Deleting a Selection

- 1, 2, 3...
1. Select "E:Edit step/trans" from the main programming menu.
 2. Select "D:Delete" from the Edit step/trans menu.
 3. Select "B:Block" from the Delete menu.

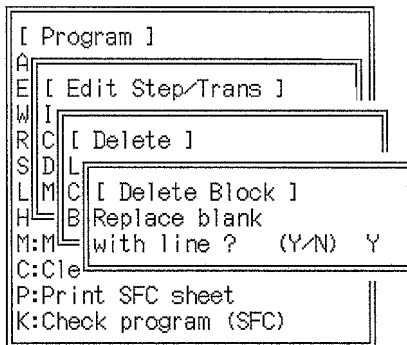

4. A message will ask if the deleted selection should be converted to vertical connections. Press the Enter Key or Y and Enter Keys to convert the deleted

selection to vertical connections. Press the N and Enter Keys to convert the deleted selection to a blank space.

5. Move the cursor to the start point of the range to be deleted and press the Enter Key.
6. Move the cursor to the end point of the range to be deleted and press the Enter Key. Specify the end point to the right of or below the start point. The specified range will be deleted and the display will revert to the programming screen.

Moving

- 1, 2, 3... 1. Select "E:Edit step/trans" from the main programming menu.
2. Select "M:Move" from the Edit step/trans menu.

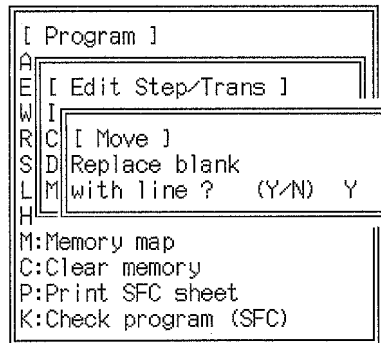

3. A message will ask if the moved selection should be converted to vertical connections. Press the Enter Key or Y and Enter Keys to convert the moved selection to vertical connections. Press the N and Enter Keys to convert the moved selection to a blank space.
4. Move the cursor to the start point of the range to be moved and press the Enter Key.
5. Move the cursor to the end point of the range to be moved and press the Enter Key. Specify the end point to the right of or below the start point. The range specified between the start and end points will be display in reverse video on the screen.

Press the Esc Key or Shift+Esc Keys to deselect the range to be moved and revert to the programming screen.

6. Move the cursor to the move destination and press the Enter Key. Specify a move destination outside the selected move range.

If the start point of the move range is an even line number, specify an even-numbered line as the destination. If the start point of the move range is an odd line number, specify an odd-numbered line as the destination.

The specified range will be moved to the destination and the display will revert to the programming screen.

Note Existing SFC parts at the move destination will be overwritten.

2-8 Jumping and Searching

2-8-1 Jumping the Cursor

The cursor can be moved to the top or bottom of the current sheet, or it can be moved to a specified column and row (line).

To jump the cursor, press the F1 Key from the base screen. The Jump menu will appear.

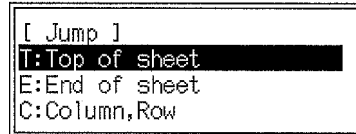

Top of Sheet

Select "T:Top of sheet" from the Jump menu. The menu will disappear and the cursor will move to the top-left SFC part of the program currently being created or edited. If no program has been created or edited, the cursor will move to the top-left of the sheet.

End of Sheet

Select "E:End of sheet" from the Jump menu. The menu will disappear and the cursor will move to the bottom-right SFC part of the program currently being created or edited. If no program has been created or edited, the cursor will move to the bottom-right of the sheet.

Col, Row

Select "C:Column, Row" from the Jump menu.

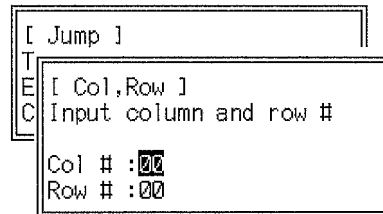

Enter the required column and press the Enter Key; then enter the required row (line) and press the Enter Key. The cursor will move to the specified column and row and the programming screen will be displayed.

When entering the row number, press the Up Key to return to the column number input position. A message in the top-left of the screen will warn you if the input column or row number exceeds the current sheet size.

2-8-2 Finding SFC Parts

SFC parts can be found and displayed by specifying the text for the desired SFC part.

- 1, 2, 3... 1. Press the F2 Key from the base screen. The Find menu will appear.

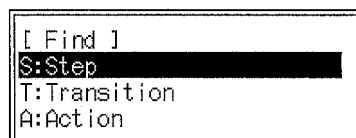

2. Select “S:Step,” “T:Transition,” or “A:Action” from the Find menu. The Find menu will disappear, the function menu at the bottom of the screen will change, and an input area will appear above the function key menu.

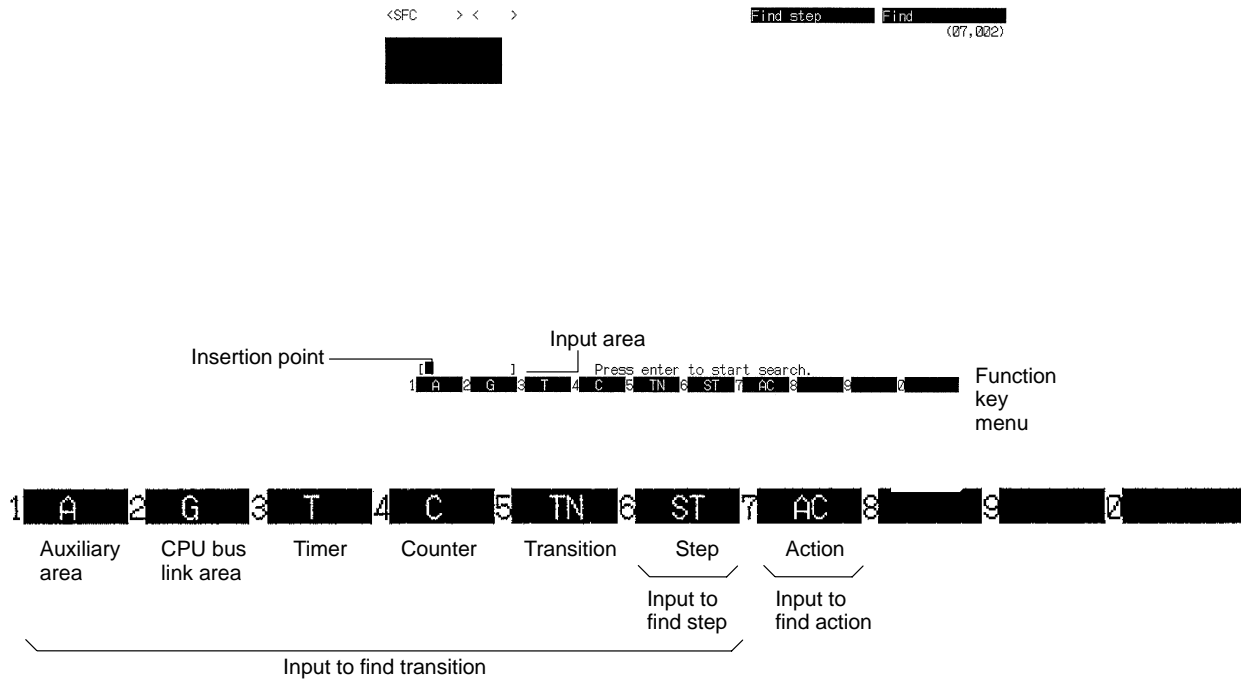

3. Input at least 2 characters of the search text according to the key table following this procedure and press the Enter Key.
The cursor will move to the SFC part if the input SFC part text is found. If the find operation is used for an action number or action I/O name, the cursor will move to the step containing the specified action number or action I/O name.
4. Press the Enter Key to repeat the find procedure for the same SFC part.
or Press the Esc Key or the Shift+Esc Keys to return to the programming screen.

Inputting the SFC Part Text

Text to Find	Key combination	Comments	Prefix
Action numbers	F7 <i>action number</i> CR	—	AC
Auxiliary Area addresses	F1 <i>bit address</i> CR	—	A
CIO Area addresses	<i>bit address</i> CR	—	—
Counter numbers	F4 <i>counter number</i> CR	—	C
CPU Bus Link Area addresses	F2 <i>bit address</i> CR	—	G
I/O names	<i>I/O name</i> CR	All I/O names starting with the input letters are found. For example, if “ab” is input, “abbb” and “abc” will be found, however, “aab” and “ccab” will not be found.	—
Step numbers	F6 <i>step number</i> CR	Subchart numbers cannot be found in subchart dummy steps.	ST
Timer numbers	F3 <i>timer number</i> CR	—	T
Transition numbers	F5 <i>transition number</i> CR	Transition bit addresses can also be found.	TN

Note 1. Leading zeros are required for CIO Area, Auxiliary Area, and CPU Bus Link Area addresses.

2. Press the Backspace Key to delete mistakes, then re-enter the number.
3. Prefixes can be designated by inputting capital letters instead of function keys. For example, **F5** may be input as **Shift+T**, **Shift+N** for an transition number.

2-9 Checking SFC Programs

The syntax of the SFC program currently being created or edited on the screen to see if it is correct. Always check a new program or an edited program. Program checking is carried out for the PC model designated in the PC Setup.

Procedure

- 1, 2, 3... 1. Select "K:Check program (SFC)" from the main programming menu.

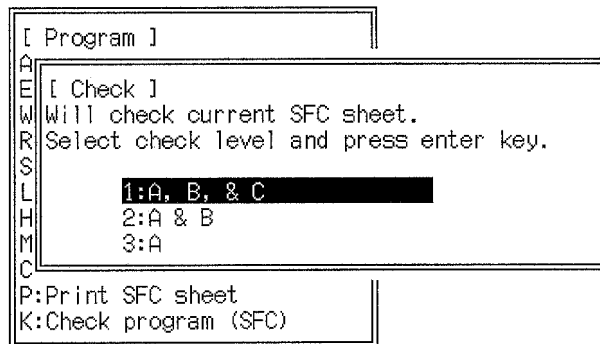

2. Select the check level from the menu. The three error check levels are described below.

Check level	Type of check
A	The program is checked to see if it is executable.
B	The program is checked to see if there are any potential problems in the combination of SFC parts used.
C	The program is checked to see if there are any potential problems in program completeness, output timing, etc.

3. Press the Enter Key to start the program check. A message will flash on the screen, and an error table will be displayed when the program check is complete.

If the error table is longer than one page, use the PgDn and PgUp Keys to switch between the pages. A message at the bottom of the screen will indicate when the last page is displayed. A maximum of 400 errors (25 pages) can be displayed. Errors exceeding this number will not be displayed.

4. Press the Esc Key to return to the previous menu.
 or Press the Shift+Esc Keys to return to the programming screen.

The time required for the program check depends on the length of the program. It may exceed 30 seconds, in some cases. The check may take more time if the program contains I/O names and/or I/O comments.

Error Messages

The errors listed in alphabetical order by check level.

Level	Error Message	Description	Remedy
A	Action # range err	The action number is too large.	Check the PC model and correct the program.
	Action bit # range err	The action bit address is too large.	

Level	Error Message	Description	Remedy
A	AQ error	The SV is out of range or not set for one of the following AQs: D, DH, L, LH, SD, DS, SL.	Check and correct the program.
	AQ hold option err	The H (hold) qualifier was used with an AQ other than N, P, R, D, or L.	
	Branch-join	Two branch lines have been connected vertically.	
	Connect err	The connecting lines are not positioned correctly.	
	Dup output bit	The same bit address has been used more than once in a single step.	
	Dup step #	The same step number has been used more than once in a single sheet.	
	Dup transition #	The same transition number has been used more than once in a single sheet.	
	Duplicate action program (1 step)	The same action number has been used more than once in a single step.	
	FV bit range err	The FV value is out of range.	
	Initial step loc. err	An initial step has been used as the entry step or return step for a subchart or interrupt.	
	Intrpt entry posi error	The interrupt entry terminal and interrupt entry step are not used as a pair or are not in the correct positions.	
	Intrpt prog err	Only a single step or transition has been created in an interrupt program.	
	Intrpt program # err	The interrupt program number is out of range (for scheduled or I/O interrupts).	
	Intrpt return posi err	The interrupt return terminal and interrupt return transition are not used as a pair or are not in the correct positions.	
	No subchart entry	No subchart entry terminal exists.	
	No subchart return	No subchart return terminal exists.	Enter a subchart return terminal.
	No intrpt return term	The interrupt return terminal does not exist.	Enter an interrupt return terminal.
	No intrpt entry term	Interrupt entry terminal does not exist.	Enter an interrupt entry terminal.
	No SFC jmp dest	No jump destination step number.	Enter a jump entry step number.
	No SFC jmp entry	No jump destination.	Check and correct the program.
	Sel branch error	Conditional branch used from multiple steps.	
	Sel join error	Conditional join used to multiple steps.	
	SFC jump posi err	The jump is connected to a branch.	
	Simul branch err	Multiple transitions have been used for a parallel branch.	
	Simul join err	Multiple transitions have been used for a parallel join.	
	Step connect err	Steps not connected correctly.	
	Step # range err	The step number is too large.	Check the PC model and correct the program.
Subchart dummy step error	A subchart dummy step has been used as a subchart/interrupt entry step or return step.	Check and correct the program.	

Level	Error Message	Description	Remedy	
A	Subchart entry posi err	The subchart entry terminal and subchart entry step are not used as a pair or are not in the correct positions.	Check and correct the program.	
	Subchart err	Only a single step has been created in a subchart program.		
	Subchart return posi err	The subchart return terminal and subchart return step are not used as a pair or are not in the correct positions.		
	Term different	Subchart or interrupt return terminal does not exist, or a different type of return terminal has been used.		
	Too many actions	More than 1,500 actions have been used in a single sheet.		
	Too many branches, joins	There is a branch to or a join from more than 15 steps.		
	Too many initial steps	More than 31 initial steps have been used in a single sheet.		
	Too many steps	More than 100 steps have been used in a single sheet.		
	Too many transitions	More than 100 transitions have been used in a single sheet.		
	Transition connect err	The transition is not connected correctly.		
	Transition # range err	The transition number is too large.		Check the PC model and correct the program.
	Transition bit # range err	The transition bit address is too large.		
	Undef. action	No action number.		Enter an action number.
	Undef. AQ	No AQ.	Enter an AQ.	
	Undef. FV bit	No bit address for the FV I/O name.	Enter a FV bit address.	
	Undef. intrpt prog #	No interrupt program number (for scheduled or I/O interrupts).	Enter an interrupt program number.	
	Undef. step	No step number.	Enter a step number.	
	Undef. subchart entry step	No subchart entry step number.	Enter a subchart entry step number.	
	Undef. transition	No transition number.	Enter a transition number.	
	Undef. transition bit	No transition bit address.	Enter a transition bit address.	
B	Branch-join	Conditional or parallel branches and joins were not used in pairs or one of the SFC parts was omitted.	Check and correct the program.	
	Connect err	The connection lines are connected incorrectly.		
	Initial step loc. error	An initial step was used in a subchart or interrupt program.		
	Intrpt entry posi err	The interrupt entry terminal and interrupt entry step are not used as a pair.		
	Multi intrpt entry terms	More than one interrupt entry terminal was used.		
	Multi subchart entries	More than one subchart entry terminal was used.		
	No initial step	An initial step does not exist.		
	SFC jump posi err	Previous SFC part was omitted.		

Level	Error Message	Description	Remedy
B	Step connect err	A branch/join line is connected to a single SFC part.	Check and correct the program.
	Subchart entry posi err	The subchart entry terminal and subchart entry step are not used as a pair.	
	Transition connect err	A branch/join line is connected to a single SFC part or the SFC parts were omitted.	
C	Dup action program	An action program number was used twice in the same sheet.	Check and correct the program.
	Dup output bit (1 sheet)	The same bit address was used more than once in a single sheet.	This problem can cause racing. Check the bit addresses once more.
	Multi loops on 1 sheet	More than one SFC program loop exists in a single sheet.	Check and correct the program.

Permitted Numeric Ranges

The permitted ranges for step numbers, transition numbers, action numbers, and bit addresses are shown in the following table.

Number/Address	Prefix	CV500-CPU01-E	CV1000-CPU01-E CV2000-CPU01-E
Action numbers	AC	0 to 1023	0 to 2047
Auxiliary Area addresses	A	0 to 51115	0 to 51115
CIO Area addresses	—	0 to 255515	0 to 255515
Counter numbers	C	0 to 511	0 to 1023
CPU Bus Link Area addresses	G	0 to 25515	0 to 25515
DM Area addresses	D	0 to 8191	0 to 24575
EM Area addresses	E	—	0 to 32765
Step numbers	ST	0 to 511	0 to 1023
Timer numbers	T	0 to 511	0 to 1023
Transition numbers	TN	0 to 511	0 to 1023

2-10 Reading and Writing Sheets

Sheets are read and written between the display buffer (main memory) and the work disk. To transfer programs between a data disk and the work disk, use the save program and retrieve program operations in the next section.

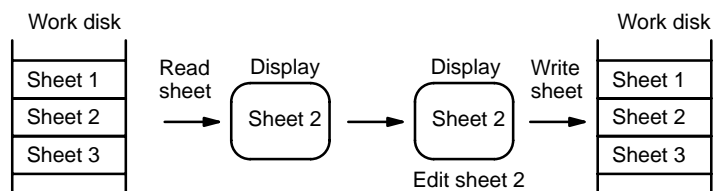

2-10-1 Writing Sheets

SFC programs created on the screen are written to the work disk. Each sheet displayed on the screen corresponds to one written sheet. When all available memory on the work disk has been used, you will not be able to continue writing the sheet and must save it. Press the End Key or Ctrl+M Keys to display the amount of memory remaining at the bottom-right corner of the screen.

To save a sheet, use "S:Save program" to write the program from work disk to the data disk, then clear the work disk before using "W:Write sheet." The procedure for doing this is given below.

Programs exceeding the work disk capacity are handled as separate programs.

- 1, 2, 3... 1. Press the End Key or Ctrl+M Keys to access the main programming menu.
2. Select "W:Write sheet" from the menu. The sheet number input area will appear.

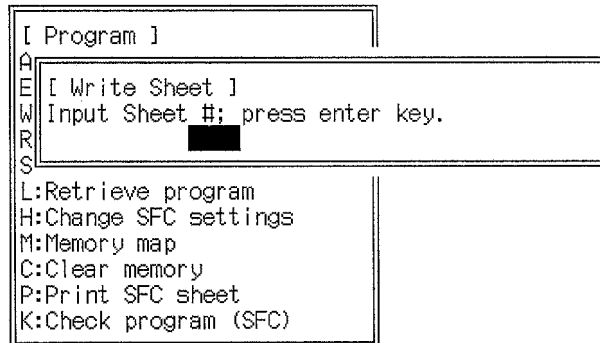

If a sheet number is displayed at the top-left of the screen, the same sheet number will be displayed in the sheet number input area.

3. Input the sheet number and press the Enter Key.

PC	Sheet no. range
CV500-CPU01-E	0 to 255
CV1000-CPU01-E CV2000-CPU01-E	0 to 511

If the input sheet number is the same as the current sheet number a message will ask if the sheet should be updated.

Press the Y and Enter Keys to update the sheet. Press the Enter Key or N and Enter Keys to cancel and input a new sheet number.

or If an existing sheet is to be updated, use the following procedure to input the sheet number:

- a) Press the End Key or Ctrl+M Keys to display the sheet table.
- b) Select the required sheet number with the cursor and press the Enter Key to input the number. The title input area appears.

4. Input the title and press the Enter Key. If an existing sheet number is selected, the title for that sheet will be displayed. The title can be up to 30 characters in length. A message will flash to indicate that the sheet is being written, and the programming screen will be displayed after the sheet has been written. The sheet number and title will be displayed in the top-left of the screen.

Note When all program sheets are cleared from the work disk, only the sheet that is currently being edited in the screen buffer will remain and nothing will be on the

work disk. In the example below, if all the programs are cleared only sheet 2, which is in the screen buffer, will remain in the computer.

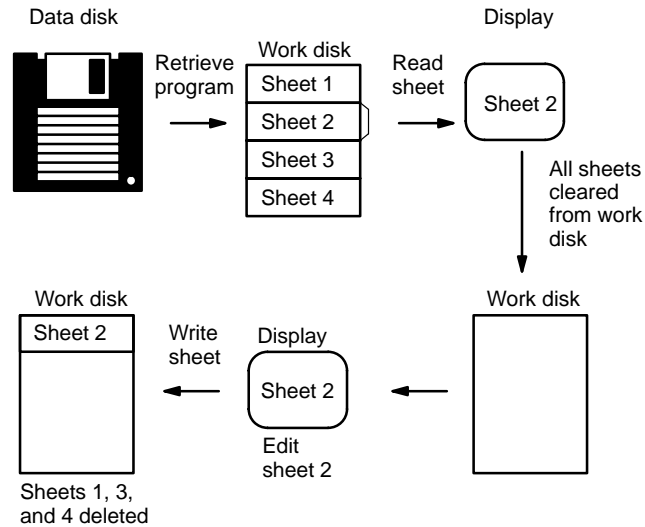

2-10-2 Reading Sheets

One sheet of the program on the work disk can be read and displayed on the screen. I/O comments and I/O names are read simultaneously with the sheet. Reading is not possible if no program exists on the work disk.

When a sheet is read, the sheet currently displayed on the screen is cleared before the specified sheet is displayed. To save the sheet being edited, use "W:Write sheet" to write the sheet to the work disk before reading a new sheet.

- 1, 2, 3...
1. Press the End Key or Ctrl+M Keys to access the main programming menu.
 2. Select "R:Read sheet" from the menu. The sheet number input area will appear.

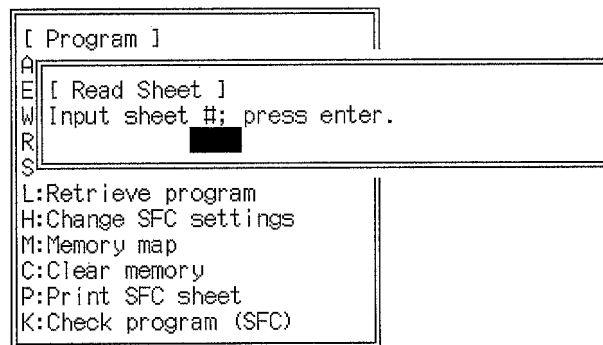

3. Press the End Key or Ctrl+M Keys to display the sheet table.
4. Select the sheet number to be read from the table and press the Enter Key.
5. Press the Enter Key to start reading the sheet. A message will flash telling you that the sheet is being read, and the programming screen will be displayed after the sheet has been read. I/O names and I/O comments will not be read if none are used in the program on the sheet. The number and title of the read sheet will be displayed in the top-left of the screen.

2-11 Saving and Retrieving Programs

Programs are saved and retrieved between the work disk and the storage devices (data disk or hard disk).

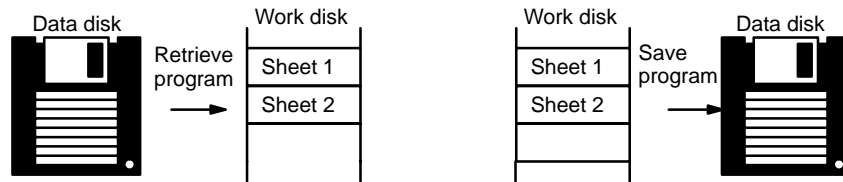

2-11-1 Saving Programs

When a program is saved, the entire program on the work disk is written to the data disk or hard disk. Ladder-diagram programs created in the program view mode are also saved, as are I/O names, I/O comments, and block comments. Before saving a program, make sure that the data disk or hard disk has been initialized. See 6-1 *Initialization* for the initialization procedure.

Programs cannot be saved if they exceed the free space available on the data disk or hard disk or if the disk is write-protected. Press the End Key or Ctrl+M Keys when the file name input area is displayed to display the amount of free space on the storage device at the bottom-right of the screen. The free memory will be displayed for the memory data disk or hard disk currently displayed in the file name input area.

- 1, 2, 3...
1. Press the End Key or Ctrl+M Keys to access the main programming menu.
 2. Select "S:Save program" from the menu. The file name input area will be displayed.

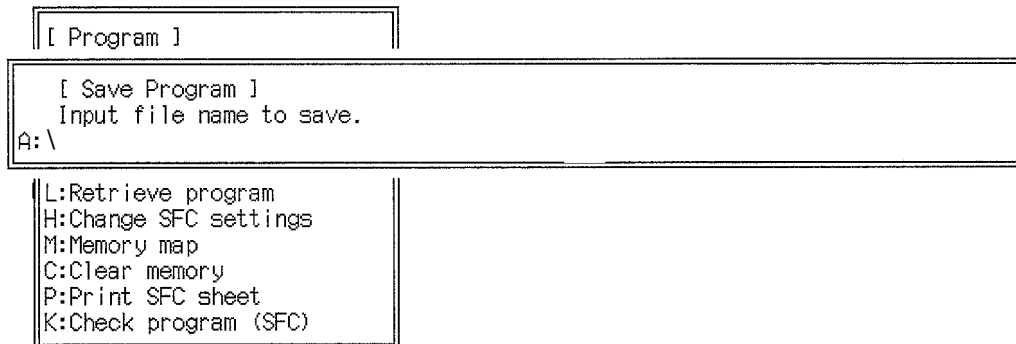

3. If writing to a data disk, insert the disk.
4. Input the file name with up to 8 characters and press the Enter Key. Drive A is set default. To change the default setting, refer to 6-2-5 *Changing the Drive and Path Name*.

When specifying directories, a single directory name can have up to 8 characters with a total of 66 characters for the entire path name. See 6-2 *File Management* for more information about the directories. Lower-case letters are automatically converted to upper-case letters.

If the input file name already exists, a message will ask if the file should be updated. Press the Y and Enter Keys to update the file. Press the Enter Key or N and Enter Keys to cancel and input a new file name.

If an existing file is to be overwritten, use the following procedure to input the file name:

- a) Press the End Key or Ctrl+M Keys to display the file names.
- b) Select the required file name with the cursor and press the Enter Key.

5. Input the title and press the Enter Key. If an existing file name is selected, the title for that file is displayed. The title can be up to 30 characters in length.
6. Press the Enter Key to save the program. After the sheet has been saved, the programming screen will be displayed, and the name of the saved file will be displayed in the top-left of the screen.

2-11-2 Retrieving Programs

This following procedure can be used to retrieve a program from the data disk or hard disk to the work disk. When a program is retrieved, all SFC, ladder, and mnemonic programs, as well as I/O names, I/O comments, and block comments are retrieved at the same time.

- 1, 2, 3... 1. Press the End Key or Ctrl+M Keys to access the main programming menu.
2. Select "L:Retrieve program" from the menu. The file name input area will be displayed.

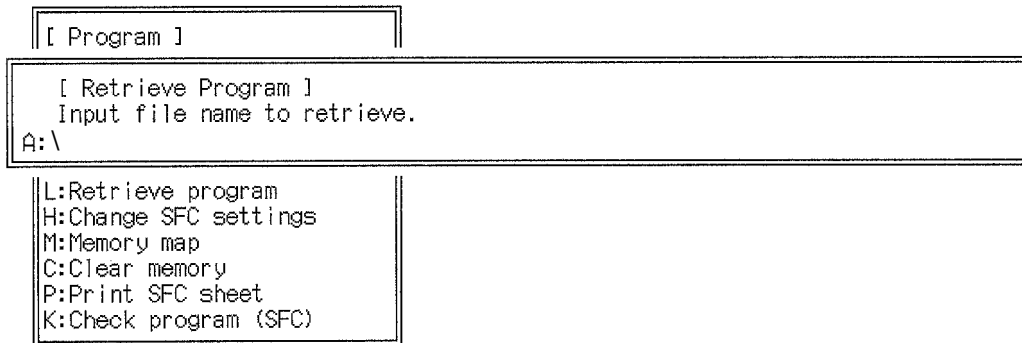

3. If using a data disk, insert the disk.
4. Press the End Key or Ctrl+M Keys to display the file names. The file names in the drive displayed in the file name input area will be displayed.
5. Select the file name to be retrieved with the cursor and press the Enter Key.
6. Press the Enter Key to retrieve the program. After the program has been retrieved, the programming screen will be displayed.
7. To display the retrieved program, read a sheet using "R:Read sheet."

2-12 Printing SFC Sheets

Before printing SFC sheets, connect and turn on the printer and load the printer paper.

2-12-1 Printing All Sheets

The following procedure is used to print out all the sheets in the work disk.

All the SFC programs in the work disk are output to the printer. If a sheet has been created or edited on the screen, it will not be printed in the current form unless it is first written to the work disk.

- 1, 2, 3... 1. Select "P:Print SFC sheet" from the main programming menu.

```
[ Program ]
A
E [ Print SFC Sheet ]
W A:All sheets
R S:Current sheet
S
L:Retrieve program
H:Change SFC settings
M:Memory map
C:Clear memory
P:Print SFC sheet
K:Check program (SFC)
```

2. Select "A:All sheets" from the menu. The default settings or the settings from the previous print operation will be displayed. Titles may be up to 60 characters long. The specifications for printing shown below are described in the following table.

```
[ Program ]
A
E [ Print SFC Sheet ]
W A
R S [ Print All Sheets ]
S
L:R Start row 000
H:C End row ( a: all ) ALL
M:M Start page ( 0-9999 ) 0000
C:C Change display [ M:I/Oname, N:addr ] N
P:P Print comments [ Y:yes, N:no ] Y
K:C Print actions [ Y:yes, N:no ] Y
Title (up to 60 chars)
Change pages within sheets? [ Y:yes,N:no ] Y
Change pages each sheet? [Y:yes,N:no] Y
OK ? (Y/N) Y
```

Item	Input	Description
Start row (line)	Line number	Print-out from input line number.
End row (line)	Line number	Print-out up to input line number.
Start page	0 to 9999	Set the page number to start printing.
Change display	M	Print program with I/O names.
	N	Print program with numbers/addresses.
Print comments	Y	Print I/O comments.
	N	Do not print I/O comments.
Print actions	Y	Print actions.
	N	Do not print actions.
Title	Character input	Printed as the title on the print-out.
Change pages within sheets?	Y	Printing will begin at the top of a new page for each SFC program, action block, and comment block.
	N	SFC programs, action blocks, and comment blocks will be printed continuously.
Change pages each sheet?	Y	Printing will begin at the top of a new page for each SFC sheet.
	N	SFC sheets will be printed continuously.

Item	Input	Description
OK?	Y	Start printing.
	N	Change settings.

3. Press the Enter Key to print using the displayed settings.
- or To change the settings, press the N and Enter Keys, select the required items with the cursor, and change the settings. The Start Line and End Line cannot be set when All sheets is selected.
 Printing will start and a message will flash during printing.
4. Press the Shift+Esc Keys or the Esc Key to cancel printing. All characters in the printer buffer will be printed before printing stops.
5. The programming screen will be displayed when printing is complete. Press the Shift+Esc Keys to return to the programming screen.
- or Press the Esc Key to return to the SFC Sheet Printing menu.

Printing Examples

The print format depends on whether the I/O comments and actions are printed.

I/O Comments, but No Actions

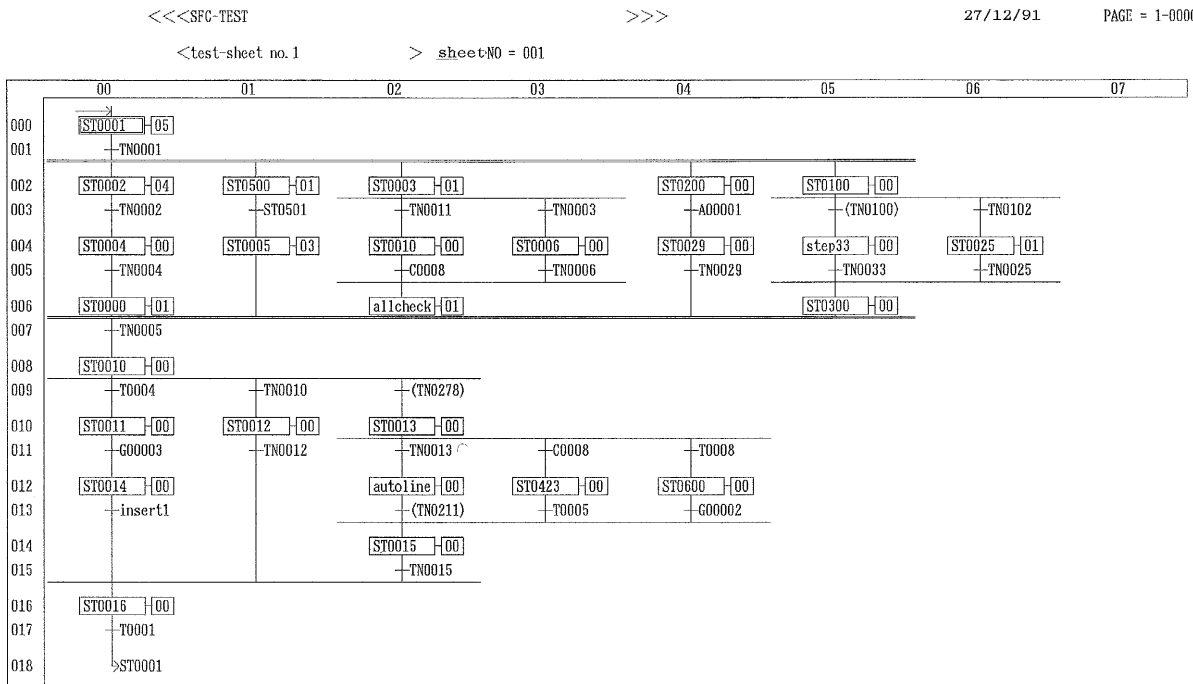

<<<<SFC-TEST <test-sheet no.1 > sheetNO = 001 >>>>

co	low	addr	I/Oname	I/O coments
00	000	ST0001		punch
00	001	TN0001		pull the die
00	002	ST0002		cylinder processing
01	002	ST0500	test20	
02	002	ST0003		upper vase plate forming
04	002	ST0200		
05	002	ST0100		
00	003	TN0002		pull the cylinder
01	003	TN0002	tran21	
02	003	TN0011		check ok?
03	003	TN0003		making pull the die
04	003	TN0010		sealing process
04	003	A00001		wait three seconds
05	003	TN0100		
05	003	TN0100		
06	003	TN0102		
00	004	ST0004		punch the front panel
01	004	ST0005		copper and vase junction
02	004	ST0010		material service
03	004	ST0006		perforating
04	004	ST0029		control conveyer
05	004	*****	step33	
06	004	ST0025		mixture of raw material D
00	005	TN0004		pull the punched panel
02	005	TN0010	check8	sealing process
02	005	C0008		judje the active condition 26
03	005	TN0006		check the perforating
04	005	TN0029		time of ejection
05	005	TN0033		
06	005	TN0025		mixture of raw material D
00	006	ST0000	test4	

<<<<SFC-TEST <test-sheet no.1 > sheetNO = 001 >>>>

27/12/91 PAGE = 001

co	low	addr	I/Oname	I/O coments
02	006	*****	allcheck	
05	006	ST0300		
00	007	TN0005		completion signal
00	008	ST0010		material service
00	009	TN0004		
01	009	TN0010		sealing process
02	009	TN0278		
02	009	TN0278		
00	010	ST0011		accept CPU
01	010	ST0012		insert axial parts
02	010	ST0013		insert radial parts
00	011	TN0003		move the cursor to the left
01	011	TN0012		parts check 1
02	011	TN0013		parts check 2
03	011	TN0500	check8	judje the active condition 26
04	011	TN0457		
04	011	TN0008		judje the active condition 25
00	012	ST0014		manual insert process
02	012	*****	autoline	
03	012	ST0423		
04	012	ST0600		
00	013	*****	insert1	
02	013	TN0211		
02	013	TN0211		
03	013	TN0444		judje the active condition 15
04	013	TN0600		judje the active condition 7
02	014	ST0015		automatic soldering
02	015	TN0015		check the soldering
00	016	ST0016		modification process

I/O Comments and Actions The actions are printed after the print-outs shown in the previous examples.

<<<<SFC-TEST

>>>>

27/12/91

PAGE = 001

<test-sheet no.1

> sheet NO = 001

(00,000) [ST0001] []

No	Action	AQ	SV	FV
01	A00009	L	A002	TN0222
02	AC0024	P	G034	T0009
03	AC0019 liquid cry stal instr uction set	PH	#0055	*****
04	AC0011 autosensor sw-on	S	D00111	A00005
05	AC0010 step flag	SD	E00220	G00004

(01,002) [ST0500] [test20]

No	Action	AQ	SV	FV
01	AC0037	RH	G052	T0004

(02,002) [ST0003] []

No	Action	AQ	SV	FV
01	AC0020 output	L	D00046	G0007

(01,004) [ST0005] []

No	Action	AQ	SV	FV
01	AC0035	LH	0110	ST0019 function t est
02	AC0014	P	A115	TN0026
03	AC0020 output	SD	#0079	*****

(00,002) [ST0002] []

No	Action	AQ	SV	FV
01	G00801	***	C0052	ST0200
02	AC0020 output	SD	T0232	TN0004 pull the p unched pan el
03	AC0013 liquid cry stal	PH	A100	*****
04	AC0005	R	D00209	ST0011 accept CPU

(06,004) [ST0025] []

No	Action	AQ	SV	FV
01	AC0022 reset outp ut	R	A007	*****

<<<<SFC-TEST

>>>>

27/12/91

PAGE = 002

<test-sheet no.1

> sheet NO = 001

(00,006) [ST0000] [test4]

No	Action	AQ	SV	FV
01	AC0030 chara disp of liquid crystal	***	C0144	*****

(02,006) [*****] [allcheck]

No	Action	AQ	SV	FV
01	AC0015 chara disp of liquid crystal	SL	E00244	A00512

Actions, but No I/O Comments

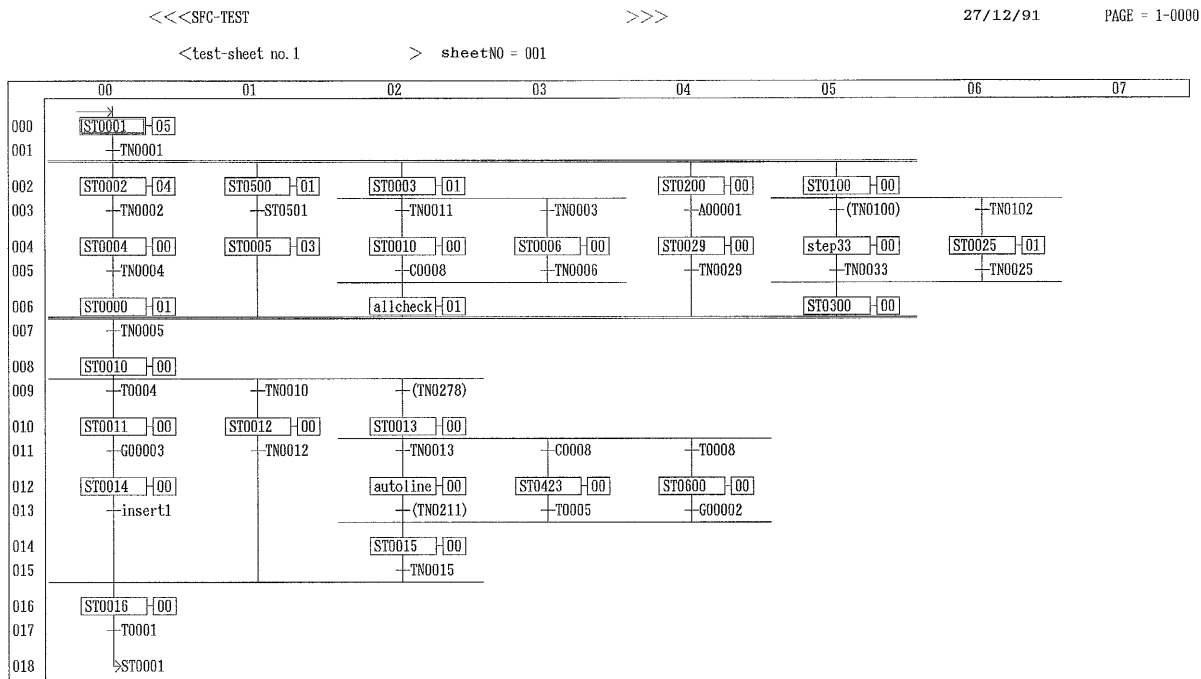

```

    <<<SFC-TEST <<<
    <test-sheet no.1 > sheetNO = 001 >>>
    27/12/91 PAGE = 001
  
```

(00,000) [ST0001] [] []

No	Action	AQ	SV	FV
01	A0009	L	A002	TN0222
02	AC0024	P	G034	T0009
03	AC0019	PH	#0055	*****
04	AC0011	S	D00111	A00005
05	AC0010	SD	E00220	G00004

(00,006) [ST0000] [test4] []

No	Action	AQ	SV	FV
01	AC0030	***	C0144	*****

(02,006) [*****] [allcheck]

No	Action	AQ	SV	FV
01	AC0015	SL	E00244	A00512

(00,002) [ST0002] [] []

No	Action	AQ	SV	FV
01	G00801	***	C0052	ST0200
02	AC0020	SD	T0232	TN0004
03	AC0013	PH	A100	*****
04	AC0005	R	D00209	ST0011

(01,002) [ST0500] [test20] []

No	Action	AQ	SV	FV
01	AC0037	RH	G052	T0004

(02,002) [ST0003] [] []

No	Action	AQ	SV	FV
01	AC0020	L	D00046	C0007

(01,004) [ST0005] [] []

No	Action	AQ	SV	FV
01	AC0035	LH	0110	ST0019
02	AC0014	P	A115	TN0026
03	AC0020	SD	#0079	*****

(06,004) [ST0025] [] []

No	Action	AQ	SV	FV
01	AC0022	R	A007	*****

2-12-2 Printing the Current Sheet

The following procedure can be used to print out the sheet currently displayed on the screen.

- 1, 2, 3... 1. Select "P:Print SFC sheet" from the menu.



2. Select "S:Current sheet" from the menu. The default settings or the settings from the previous print operation will be displayed.
3. Set the start line and end line.

The rest of the procedure is identical to that for printing all the sheets given in the previous section.

2-13 Overview Mode

The overview mode displays a large-scale view of a large range of the SFC program created in the detail view mode. The overview mode does not allow a program to be created or edited, and action blocks cannot be displayed. Parallel connections displayed as double lines in the detail view mode are displayed as a single horizontal line in the overview mode. The overview mode display format depends on the current screen size setting. See 2-4 *Changing SFC Settings* for information on the screen size setting.

To change to the overview mode, press the F3 Key from the detail view screen. The overview screen will be displayed. Press the Esc Key or Shift+Esc Keys from the overview screen to return to the detail view screen.

Overview Screen

The main menu and sub-menus are displayed in the top-right corner of the screen. The function key menu is displayed at the bottom of the screen for the F1 and F2 Keys.

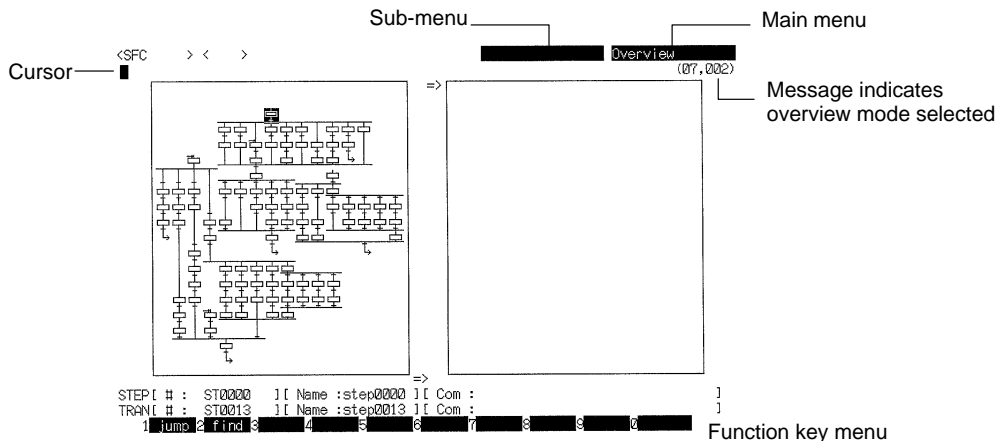

Moving the Cursor

The cursor can be moved in units of steps or transitions.

Using the Arrow Keys

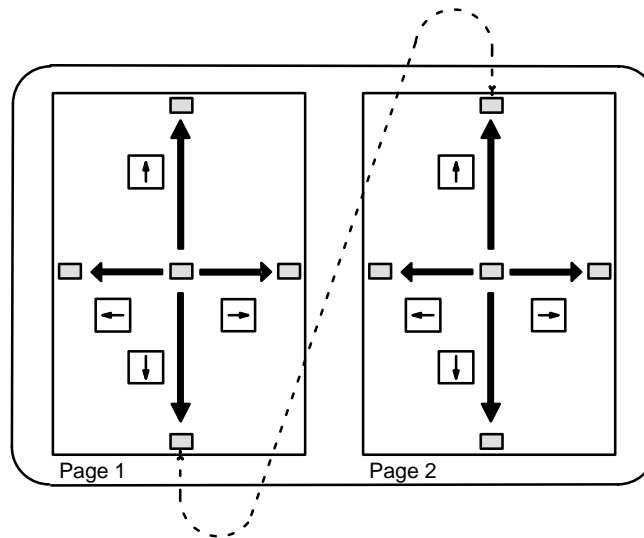

- 1, 2, 3...**
1. Press the Up and Down Keys to move the cursor vertically.
 - If the Down Key is pressed when the cursor is at the bottom of the first page, the cursor will move to the top of the second page.
 - If the Up Key is pressed when the cursor is at the top of the second page, the cursor will move to the bottom of the first page.
 - If the Up key is pressed when the cursor is at the top of the first page, the SFC part on the previous line will appear on the first page of the overview screen.
 - If the Down Key is pressed when the cursor is at the bottom of the second page, the SFC part on the next line will appear on the second page of the overview screen.
 2. Press the Left and Right Keys to move the cursor horizontally.

Note The cursor itself will not move if the Up Key is pressed when the cursor is at the top of the first page or if the Down Key is pressed when the cursor is at the bottom of the second page.

Using the PgDn and PgUp Keys

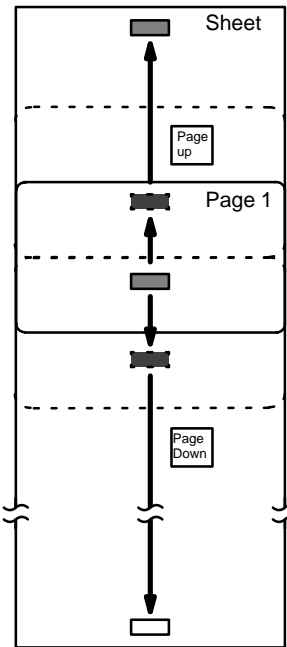

When the PgDn Key is pressed, the displayed lines move up half a page, so that the previous bottom half of the display appears at the top of the screen and lines previously below the screen are displayed in the bottom half of the screen. The cursor position on the screen remains unchanged. However, if the display is scrolled to the end of the sheet, the cursor will move to the bottom of page 2 (or page 4, depending on the sheet size setting).

When the PgUp Key is pressed, the displayed lines move down half a page, so that lines previously above the screen are displayed in the top half of the screen. The cursor position on the screen remains unchanged. However, if the display is scrolled to the start of the sheet, the cursor will move to the top of page 1.

The size of each page depends on the current sheet size setting, as follows:

- 16C * 100R 32 rows (lines) * 16 columns displayed
- 8C * 200R 32 rows * 8 columns displayed

Jumping

The cursor position can be jumped as described for the detail view mode. See *2-8 Jumping and Searching* for details.

Searching

SFC parts can be found as described for the detail view mode. See *2-8 Jumping and Searching* for details.

2-14 Program View Mode

The program view mode allows ladder-diagram programs to be created and edited for specified action and transition programs. This section describes the procedure for selecting the program view mode. See *Section 3 Ladder Diagram Programming* for information on programming ladder diagrams.

Preparations

Writing the Sheet

The sheet has to be written before changing to program view mode. If the program view mode is selected without first writing the sheet to the disk, any changes made to the sheet since it was last written to disk will be lost.

Positioning the Cursor

In the program view mode, only steps, transitions, and blanks are displayed. Before entering program view, move the cursor to a step containing at least one action or a transition with a transition number.

Procedure

Specifying Steps

- 1, 2, 3...
1. Select the step with the cursor in detail view. Be sure to move the cursor to a step containing at least one action.
 2. Press the F4 Key. The action block will be displayed for the step selected by the cursor. A message will warn the operator if the selected step contains no actions.
 3. Use the PgUp and PgDn Keys and the Up and Down Keys to select the action from the action block the press the Enter Key. Only select an action assigned with an action number. A message will warn the operator if the selected action is assigned a data memory address.
 4. Press the Enter Key to select the program view. A message will warn the operator that the current sheet will be lost if it has not been written.
 5. Press the N and Enter Keys to cancel the operation and return to the current program display. In this case, write the required sheet and repeat the steps above.

Specifying Transitions

- 1, 2, 3...
1. Select the transition with the cursor in detail view. Be sure to move the cursor to a transition with a transition number.
 2. Press the F4 Key to select program view. A message will warn the operator if the selected transition has no transition number. Another message will warn the operator that the current sheet will be lost if it has not been written
 3. Press the N and Enter Keys to cancel the operation and return to the current program display. In this case, write the required sheet and repeat the steps above.

Specifying Blanks

- 1, 2, 3...
1. A blank is specified in order to directly input a transition number or action number and move to the program view screen.
 2. Select a blank area with the cursor in detail view.
 3. Press the F4 Key. A message at the bottom of the screen will prompt for input of a transition or action number.
 4. Enter the transition or action number and press the Enter Key.

Program View Screen

Press the Esc Key or Shift+Esc Keys to return from program view to detail view.

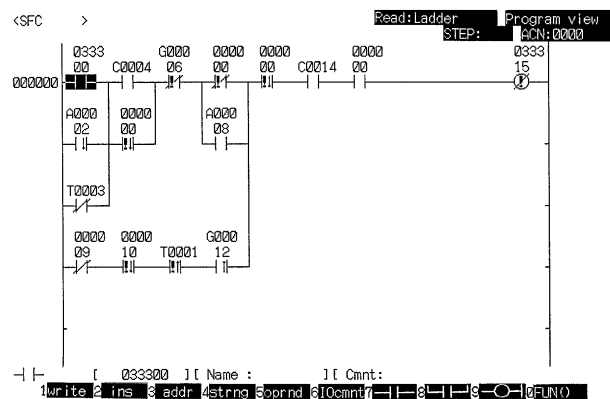

SECTION 3

Ladder Diagram Programming

This section provides the procedures required to perform ladder diagram programming. Ladder diagram programming is performed using menus and examples of their use are provided. Read the CV500/CV1000 Operation Manuals and Installation Guide before performing ladder diagram programming.

3-1	Programming Menu	64
3-2	Clearing Memory	65
3-2-1	Programming in Ladder Diagrams Only	66
3-2-2	SFC and Ladder Diagrams	69
3-3	Memory Display	69
3-4	Switching the Display	70
3-5	Programming in Ladder Form	75
3-5-1	Entering Ladder Diagrams	77
3-5-2	Store/Store Insert	90
3-5-3	Reading and Searching Ladder Diagrams	93
3-5-4	Including I/O Comments in Ladder Diagrams	99
3-6	Creating Block Comments	99
3-7	Editing Instruction Blocks	101
3-8	Changing Addresses	103
3-8-1	Changing Bit Addresses and TIM/CNT Numbers	103
3-8-2	Changing Words Addresses	108
3-8-3	Changing Words and Bit Address Together	109
3-9	Editing Interrupt Programs	111
3-10	Programming in the Mnemonic Display Mode	112
3-10-1	Entering Programs	113
3-11	Checking the Program	119
3-12	Saving and Retrieving Programs	121
3-12-1	Saving Programs	121
3-12-2	Retrieving Programs	123
3-13	Printing	124

3-1 Programming Menu

The the ladder programming screen will be displayed at the following times:

- When the program type is set to ladder in the System Setup or
- When the program type is set to SFC+ladder in the System Setup and program view entered from detail view to create an action or transition program.

Ladder Programming Screen



Press the End Key or Ctrl+M Keys from the main ladder programming screen to display the main programming menu or press the Esc Key or Shift+Esc Keys to return to the ladder programming screen.

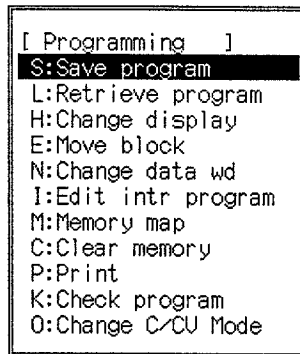

Note "I>Edit intr program" and "M:Memory map" are not displayed when the program type is set to SFC+ladder.

Editing Modes

The following editing mode can be selected with the function keys displayed at the bottom-left of the screen. All of the operations on the main ladder programming menu are possible in both read or write mode and in both ladder and mnemonic display modes except that "E:Move block" and "M:Memory map" are not possible when displaying programs in mnemonic form.

Editing mode		Function
Read	Read	Set to display the program from the work disk on the screen.
	Find	Set to find an address, character string (mnemonic instruction, I/O name, etc.), instruction, operand, I/O comment, or block comment.
Write	Write	Set to create or edit a program on the screen.
	Store Store insert	Set to write a ladder program created on the screen to the work disk. Always ladder programs created on the screen in ladder form; they are not saved automatically. This mode is not available when creating mnemonic programs on the screen as these programs are automatically written to the work disk.
Insert		Set to insert data into a program displayed on the screen.

3-2 Clearing Memory

This operation is used to clear ladder-diagram programs (including I/O names, I/O comments, and block comments) from the work disk. The clear memory operation is available in all display modes and all editing modes.

Always clear the memory before creating a program. I/O names, I/O comments, and block comments are cleared at the same time as the user programs.

When using SFC programming, only the memory areas containing ladder and mnemonic programs created in the program view mode are cleared.

If the program type is set for only ladder diagrams, the following memory areas can be specified when using the clear memory operations:

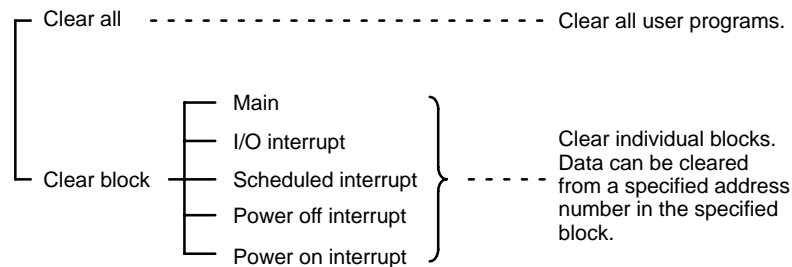

The blocks specified for the clear block operation refer to the ladder programs and subroutine programs for interrupt processing.

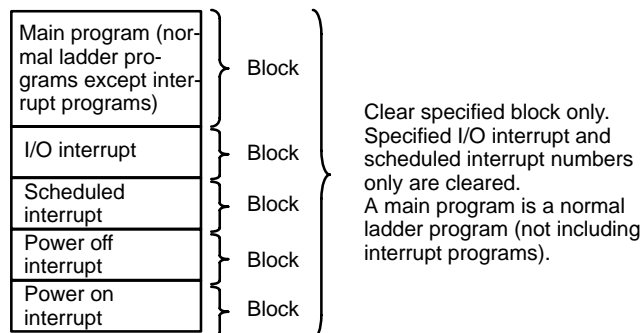

Related Operations

Use "E:Move block" to clear parts of a ladder program.

3-2-1 Programming in Ladder Diagrams Only

The Clear Memory menu is displayed when "C:Clear memory" is selected from the main menu.

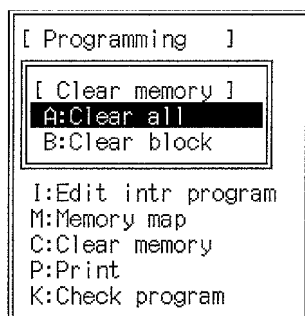

Select the appropriate item to clear all or part of the user program.

Clearing the Entire Program

- 1, 2, 3... 1. Select "A:Clear all" from the menu. A message will ask for confirmation.

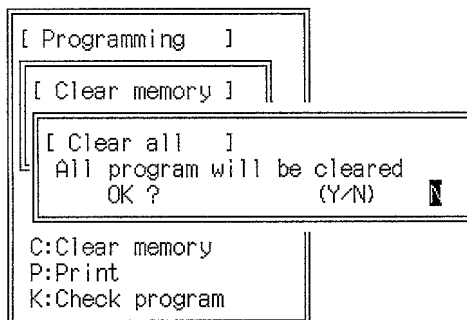

2. Press the Y and Enter Keys to clear the memory. After the memory is cleared, the Ladder Programming Screen will be displayed.

Clearing Part of the Program

Select "B:Clear block" from the menu. A message will ask whether to clear the entire specified block or steps of the specified block from a designated address.

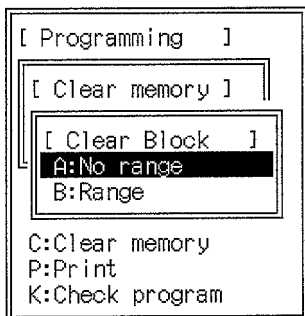

No Specified Ranges

- 1, 2, 3... 1. Select "A:No range" from the menu.

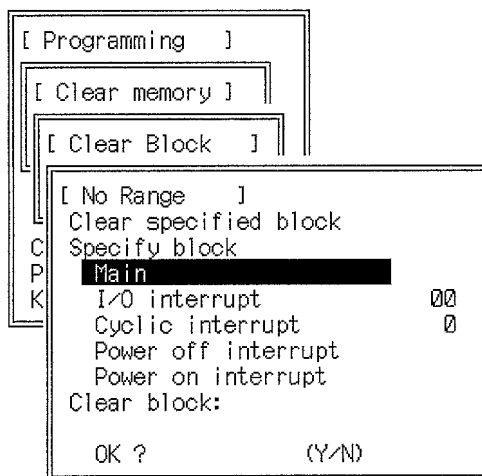

2. Press the Up and Down Keys to select the block to be cleared and press the Enter Key. After selecting an I/O interrupt or scheduled interrupt, input the interrupt number to be cleared (in the ranges shown below) and press the Enter Key.

- I/O interrupts: 0 to 31
- Cyclic (scheduled) interrupts: 0 or 1

3. Press the Enter Key after selecting the block. A message will ask for confirmation.

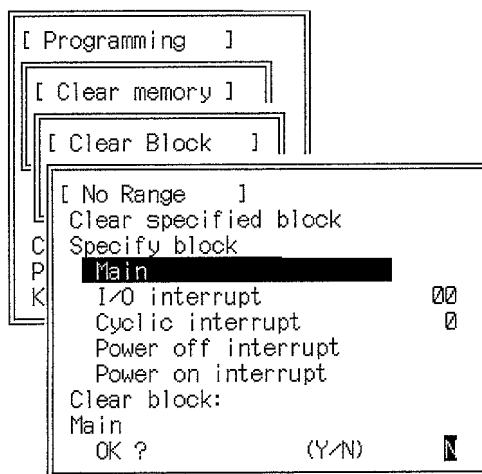

4. Press the Y and Enter Keys to delete the block. After the block have been cleared, the Ladder Programming Screen will be displayed.

Specified Ranges

- 1, 2, 3... 1. Select "B:Range" from the menu.

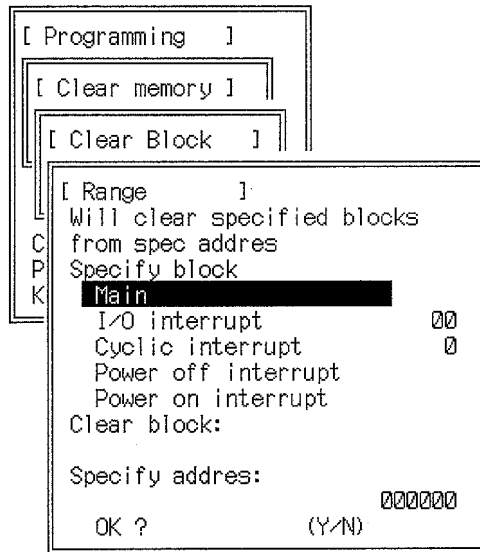

2. Press the Up and Down Keys to select the block to be cleared and press the Enter Key. After selecting an I/O interrupt or scheduled interrupt, input the interrupt number to be cleared (in the ranges shown below) and press the Enter Key.
- I/O interrupts: 0 to 31
 - Cyclic (scheduled) interrupts: 0, 1
3. Press the Enter Key after selecting the block.
4. An input area will displayed for the input of the start address from which the block is cleared.
5. Input the address and press the Enter Key. A message will ask for confirmation.

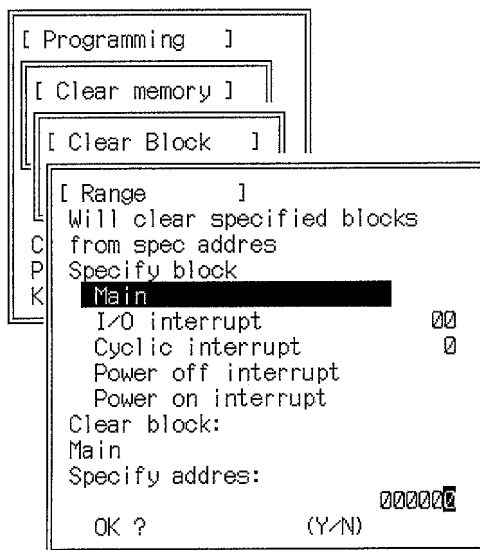

6. Press the Y and Enter Keys to delete the block from the specified start address. After the block is cleared, the Ladder Programming Screen will be displayed.

3-2-2 SFC and Ladder Diagrams

- 1, 2, 3... 1. Select "C:Clear memory" from the main menu. The Clear Memory menu will be displayed.

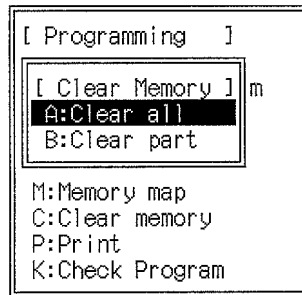

2. Select the appropriate item to clear all action and transition programs or only action and transition programs after a specified address. The clear memory operation operates on the action and transition programs currently in memory.

Clearing All Programs

- 1, 2, 3... 1. Select "A:Clear all" from the menu. A message will ask for confirmation.

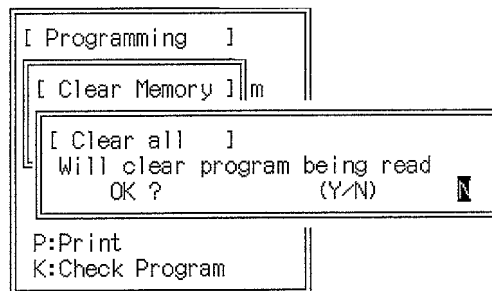

2. Press the Y and Enter Keys to clear the programs.

Clearing Part of the Programs

- 1, 2, 3... 1. Select "B:Clear block" from the menu. An input area will be displayed for the input of the start address from which the program will be cleared.

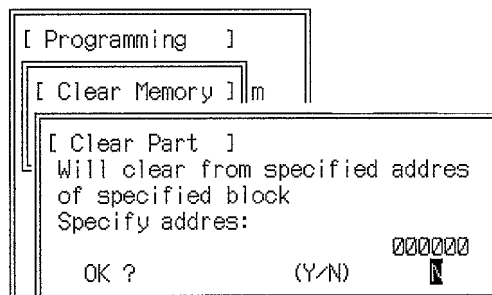

2. Input the address and press the Enter Key. A message will ask for confirmation.
3. Press the Y and Enter Keys to delete the programs from the specified start address. After the block has been cleared, the Ladder Programming Screen will be displayed.

3-3 Memory Display

This operation is used to display the status of the programs on the work disk memory area and the capacity required to hold the program when it's transferred

to the PC. The memory map operation is available in all display modes and all editing modes.

Note The memory display operation is not possible in program view for SFC programming. Switch to detailed view to display memory.

Select "M:Memory map" from the main memory. The following display will appear.

When finished, press the Shift+Esc Keys to return to the programming screen or press the Esc Key to return to the main menu.

```

[ Programming ]
S
L [ Memory Map ]
H PC memory required      Setup :    7,690 wd
N                               Reserved :    476 wd
I                               Ladder  :    435 wd
M PC memory left          :    56,935 wd ( 87%)
C
P CVSS memory used       Reserved :    2,071 wd ( 6%)
R                               Ladder  :     618 wd ( 1%)
K
O I/O names used          :         74
  I/O comments used      :         106 (   3,498byte)
  Block comments used    :          12 (     269byte)
    
```

PC Memory Required

The capacity of PC user memory required to hold the extended PC Setup and all programs if the data currently held in the CVSS work area is transferred to the PC.

PC Memory Left

The amount of PC memory remaining after subtracting the value displayed for "PC memory required."

CVSS Memory Used

Displays the number of words used by the user programs on the work disk. The number in parentheses () indicates the percentage of the total memory used.

I/O Names, I/O Comments, and Block Comments Used

The total number of each item is displayed.

Memory Capacities

Item	Capacity
User program	64 KW
I/O names	10,000
I/O comments	10,000
Block comments	512

Note The values in the table are valid when the program type is set to SFC+Ladder.

3-4 Switching the Display

This operation is used to change the display mode. The Change Display operation is available in all display modes and all editing modes.

The current ladder program will be lost if the display mode is changed to mnemonic without first saving the ladder program using the store or store insert operations. The following message will warn the operator if an attempt is made to

switch the display mode without first saving the current ladder program. Press the Enter Key and save the program before switching the display mode.

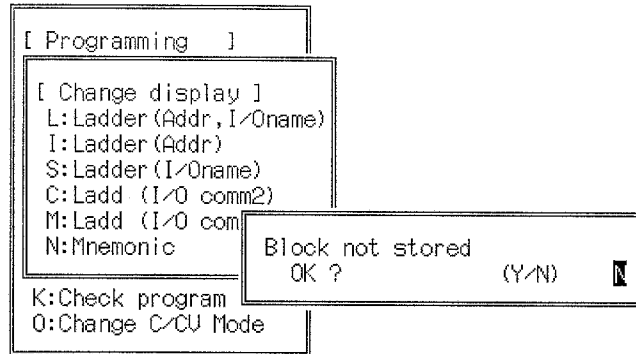

Programs written in mnemonic form are automatically written to the disk, so there is no danger of accidentally deleting them.

Program Display Modes

Display mode	Function
Ladder (Addr, I/O names)	Used to display and create ladder diagrams with I/O addresses and I/O names.
Ladder (Addr)	Used to display and create ladder diagrams with I/O addresses only.
Ladder (I/O names)	Used to display and create ladder diagrams with I/O names only.
Ladder (I/O comment 2)	Used to display and create ladder diagrams with I/O addresses and 2 lines of I/O comments.
Ladder (I/O comment 4)	Used to display and create ladder diagrams with I/O addresses and 4 lines of I/O comments.
Mnemonics	Used to display and create ladder-diagram programs in mnemonic form.

Instruction Blocks

An instruction line and all the instruction lines with which it interconnects are called an instruction block. Instruction blocks requiring more than 22 program lines cannot be written in ladder form and must be written in mnemonic form instead.

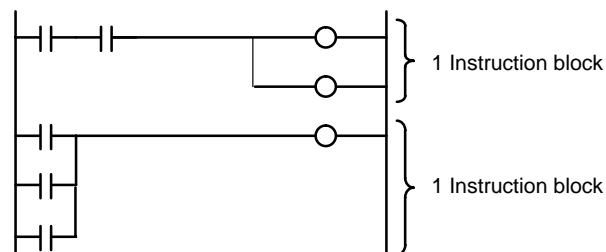

Procedure

- 1, 2, 3... 1. Select "H:Change display" from the main menu.

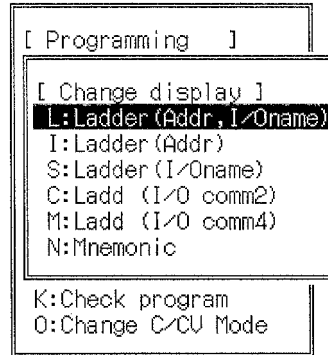

2. Select the desired display mode from the menu. The selected display mode will appear on the screen and is indicated at the top-right of the screen.

You can switch from addresses and I/O names, to addresses only, to I/O names only and then back to I/O names by pressing the Ctrl+G Keys.

Display Modes

Ladder Diagrams with Addresses and I/O Names

Up to 22 instruction lines can be input at one time in this display mode. The program must be stored after each 22 instruction lines are input. Multiple lines are required for OR conditions, SFT instructions, and other multiple-input instructions. Each page can display up to 5 instruction lines.

I/O names can normally be between 2 and 8 letters long, but only 5 letters are displayed on ladder diagrams. I/O comments for I/O bits are not displayed on the ladder diagram.

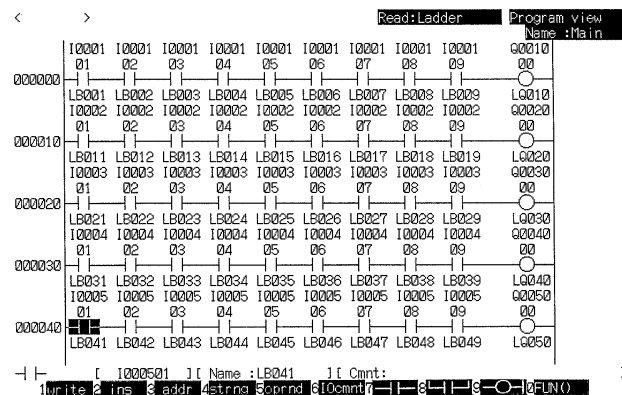

Ladder Diagrams with I/O Addresses Only

Up to 22 instruction lines can be input at one time in this display mode. The program must be stored after each 22 instruction lines are input. Multiple lines are required for OR conditions, SFT instructions, and other multiple-input instructions. Each page can display up to 7 instruction lines.

I/O comments for I/O bits are not displayed on the ladder diagram.

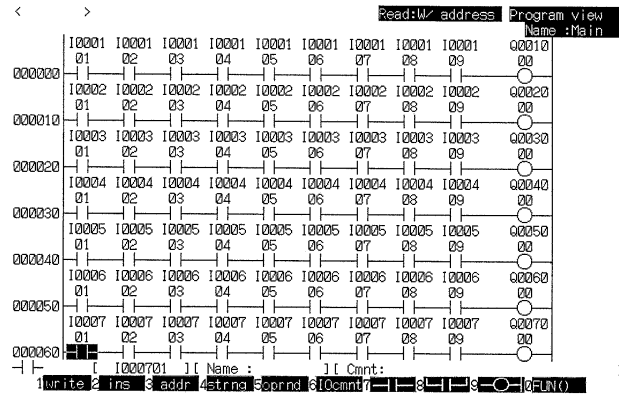

Ladder Diagrams with I/O Names Only

Up to 22 instruction lines can be input at one time in this display mode. The program must be stored after each 22 instruction lines are input. Multiple lines are required for OR conditions, SFT instructions, and other multiple-input instructions. Each page can display up to 10 instruction lines.

I/O names can normally be between 2 and 8 letters long, but only 5 letters are displayed on ladder diagrams. I/O comments for I/O bits are not displayed on the ladder diagram.

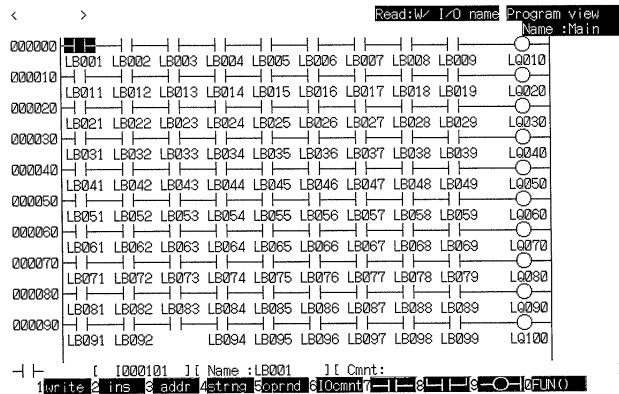

Ladder Diagrams with I/O Addresses and Two Lines of I/O Comments

Up to 22 instruction lines can be input at one time in this display mode. The program must be stored after each 22 instruction lines are input. Multiple lines are required for OR conditions, SFT instructions, and other multiple-input instruc-

tions. Each page can display up to 4 instruction lines. Two lines of I/O comments are displayed

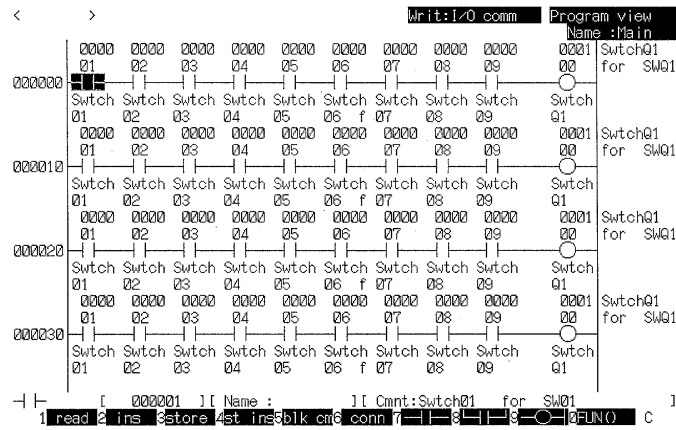

Ladder Diagrams with I/O Addresses and Four Lines of I/O Comments

Up to 22 instruction lines can be input at one time in this display mode. The program must be stored after each 22 instruction lines are input. Multiple lines are required for OR conditions, SFT instructions, and other multiple-input instructions. Each page can display up to 3 instruction lines. Four lines of I/O comments are displayed

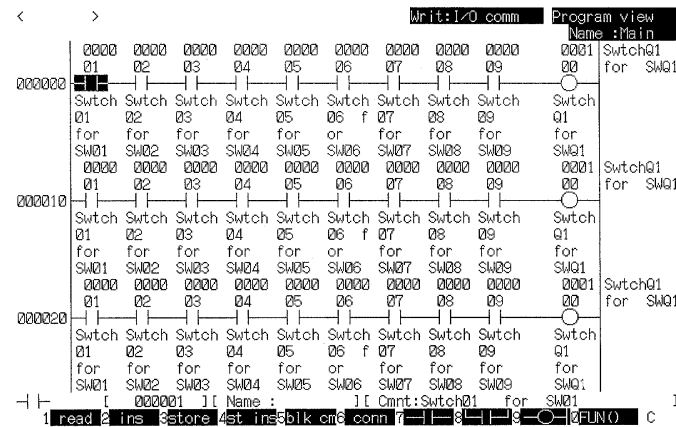

Mnemonic Ladder Programming

When a program is created in mnemonic form, it is automatically written to the work disk. I/O names can normally be between 2 and 8 letters in length, but only 5 letters are displayed in the mnemonic program. I/O comments can be up to 30 characters long. All I/O comments created in the mnemonic display mode can be

displayed. Block comments cannot be created in the mnemonic display mode. Create block comments in a ladder program display mode if they are required.

```

<      >      Read      Mnemonic
Addr  Instruction  I/O      I/O com  Name :Main
000000 LD          000101  OMRON omron OMRON omron
000001 AND          000102
000002 AND          000103  25/12/1991
000003 AND          000104
000004 AND          000105  control
000005 AND          000106
000006 AND          000107  CU1000
000007 AND          000108  CU500
000008 AND          000109
000009 OUT         001000
000010 LD          002001
000011 AND          002002
000012 AND          002003
000013 AND          002004
000014 AND          002005
000015 AND          002006
000016 AND          002007
000017 AND          002008
000018 AND          002009
000019 OUT         002000
LD      [ 000101 ] [ Name : ] [ Cmt:OMRON omron OMRON omron ]
write 2 ins 3 addr 4 string 5 brand 6 LD 7 AND 8 OR 9 OUT 0 RUN()
    
```

Switching Between the Display Modes

It is important to realize that only one user program exists on the work disk, although it can be displayed in various display modes. As shown in following diagram, there is no way to enter the mnemonic display mode without reading from the work disk. The current ladder program will thus be lost if the display mode is changed to mnemonic form without first saving the ladder program using the store or store insert operations. If a program that contains a block with more than 22 instruction lines is read, the display mode will automatically switch to mnemonic form.

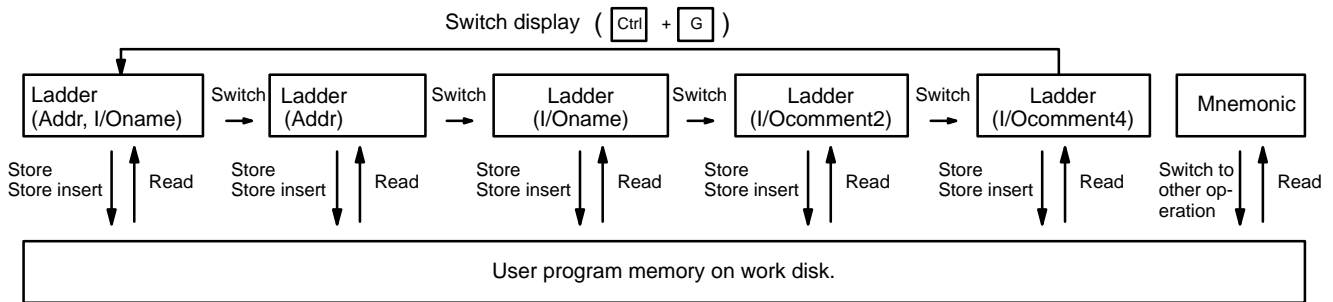

3-5 Programming in Ladder Form

The method of creating programs in the ladder form is described in this section using the Ladder (Addr, I/Oname) display mode as an example. Programming in the Ladder (Addr) or Ladder (I/Oname) mode is identical. Refer *3-5-4 Including I/O Comments in Ladder Diagrams* for details on inputting I/O comments. Do not forget to store a completed ladder program.

Preparations

Clearing Memory

Delete the contents of the memory before creating a new program. Existing programs will be overwritten if not deleted before a new program is written.

Setting the Display Mode

The default display mode is the Ladder (Addr, I/Oname). If necessary, switch the display mode to Ladder(Addr) or Ladder(I/Oname). Block comments can only be created in the Ladder(Addr, I/Oname), Ladder(I/O comment 2), or Ladder(I/O comment 4) display mode.

Setting the Editing Mode

Press the F1 Key to select the write mode for ladder diagrams.

Ladder Program Input Screen

The editing mode and display mode are displayed at the top-right of the screen. The default editing mode is the read mode.

Press the F1 to F10 Keys to select items from the function key menu displayed at the bottom of the screen. Press the Shift Key to change the function key menu.

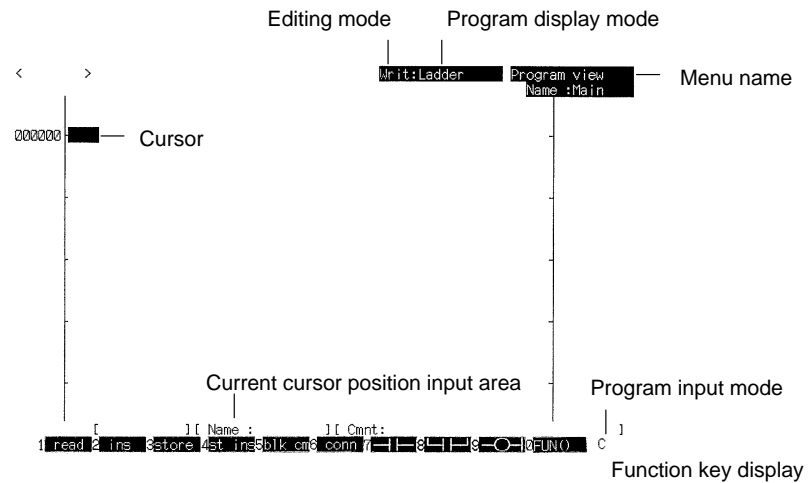

Function Keys in the Write Mode

Function key	Display	Function	Page
F1	read	Selects the read mode.	93
F2	ins	Selects the insert mode.	89
F3	store	Writes the ladder program created on the screen to the work disk. After creating or editing a program, always store it with this function key. Existing programs are overwritten during editing.	90
F4	st ins	Allows all or part of a program existing on the work disk to be edited and inserted in front of the original program on the work disk.	90
F5	blk cm	Creates block comments or inserts a block comment between other block comments.	99
F6	conn	Creates and deletes ladder connections.	83
F7	— —	Inserts an AND instruction at the cursor position.	80
F8	└─┴─┘	Inserts an OR instruction at the cursor position.	78
F9	—○—	Inserts an OUT instruction.	78
F10	FUN()	Inserts an instruction using a function code.	80
Shift+F1	—	Inserts a horizontal connection at the cursor position.	82
Shift+F2		Inserts a vertical connection at the top-left of the cursor position.	82
Shift+F3	DIFU	Inserts a DIFFERENTIATE UP instruction.	78
Shift+F4	DIFD	Inserts a DIFFERENTIATE DOWN instruction.	78
Shift+F5	TIM	Inserts a TIMER instruction.	80
Shift+F6	CNT	Inserts a COUNTER instruction.	78
Shift+F7	— /—	Inserts an AND NOT instruction at the cursor position.	78
Shift+F8	└─┴─┘/	Inserts an OR NOT instruction at the cursor position.	78
Shift+F9	—○— /	Inserts an OUT NOT instruction.	78
Shift+F10	!	Sets the immediate refresh version of an instruction (updated when the instruction is executed).	78

Moving the Cursor

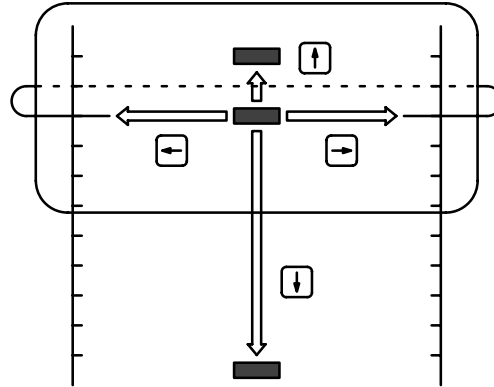

- 1, 2, 3...**
1. Press the Up and Down Keys to move the cursor up and down.
 2. Press the Left key to move the cursor left. From the left edge of the sheet, the cursor will move to the right edge.
 3. Press the Right key to move the cursor right. From the right edge of the sheet, the cursor will move to the left edge.

The ladder diagram contains a maximum of 22 instruction lines, but some of these may not be visible on the screen. The maximum number of lines on the screen in each display mode are as follows:

Ladder (Addr, I/Oname):	5 lines
Ladder (I/Oname):	7 lines
Ladder (Addr):	10 lines
Ladder (I/O comment 2):	4 lines
Ladder (I/O comment 4):	3 lines

3-5-1 Entering Ladder Diagrams

To enable entering ladder diagrams, press the F1 Key to select the write editing mode. The write mode will be displayed at the top-right of the screen.

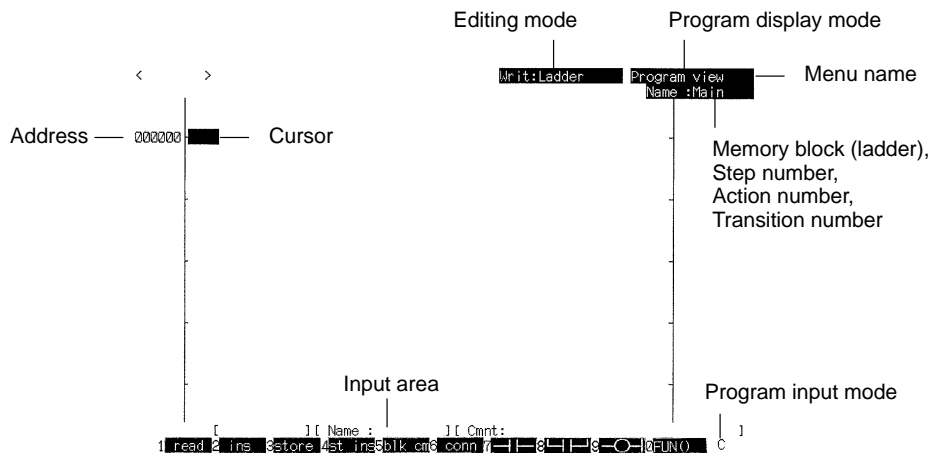

Entering Conditions

The cursor will be displayed at the first line, address 000000. If a program already exists at the cursor position, the symbol and bit address will appear in the input area at the bottom of the screen. Enter conditions on the ladder diagram using the following procedure:

- 1, 2, 3...**
1. Move the cursor to the required position.
 2. Press a function key to enter the required condition. The selected symbol will appear in the input area.

3. Enter the bit address for the condition and press the Enter Key.
 Instructions can be entered using the function keys or using the mnemonics for the instructions. When inputting mnemonics, set the program input mode to CV mode. Mnemonics cannot be input in C mode.
 I/O names can be input instead of bit addresses, provided the bit address has already been allocated an I/O name using the Edit I/O name operation (see 4-1 Editing I/O Names).

Entering Conditions on the Ladder Diagram

In the following table, items in parentheses are not required when inputting the program in C mode, but are required when inputting in CV mode.

Instruction	Symbol	Function key inputs	Mnemonic inputs	Remarks
LD AND		(F7) Bit_address CR	LD _ Bit_address CR AND _ Bit_address CR	—
LD NOT AND NOT		Shift+F7 Bit_address CR	LD _ NOT _ Bit_address CR AND _ NOT _ Bit_address CR	LD NOT and AND NOT can also be input using the Slash (/) Key: (F7) / Bit_address CR.
OR		F8 Bit_address CR	OR _ Bit_address CR	—
OR NOT		Shift+F8 Bit_address CR	OR _ NOT _ Bit_address CR	OR NOT can also be input using the Slash (/) Key: F8 / Bit_address CR.
Immediate update instruction	!	Instruction Bit_address Shift+F10 CR	Instruction _ Bit_address Shift+F10 CR	To set both the immediate update (!) and differentiate instructions, enter them consecutively.
Differentiate up instruction	j	Instruction Bit_address Shift+F3 CR	Instruction _ Bit_address Shift+F3 CR	However, only the immediate update (!) is available with the NOT instructions. The differentiate instructions cannot be used.
Differential down instruction	i	Instruction Bit_address Shift+F4 CR	Instruction _ Bit_address Shift+F4 CR	

Note I/O names can be used instead of the bit addresses. Mnemonics can be input in either upper-case or lower-case letters. Refer to page 113 for information on inputting OR, LD, AND, and LD. The F7 Key need not be input in C mode.

Entering Other Instructions

To enter basic righthand instructions, move the cursor to the right of the rightmost input. A break will appear in the connecting line if an output is entered when the cursor is not to the right of the rightmost input. Use the line connect operations (see page 82) to rejoin the connection if this problem occurs.

The number of condition permitted on any line depends on the number of operands for the righthand instruction. If it is not possible to enter all conditions on a single line, use the continue operation to join the line to the next line. Refer to page 85 for information on the continue operation.

Instructions can be entered with the function keys or as mnemonics. When inputting mnemonics, set the program input mode to CV mode. Mnemonics cannot be input in C mode.

I/O names can be input instead of bit addresses, word addresses, or timer/counter numbers, provided the I/O names have been allocated using the Edit I/O name operations (see 4-1 Editing I/O Names).

Refer to the table of advanced instructions for details about function codes. Refer to *CV500/CV1000 Operation Manual: Ladder Diagrams* for information on the operands for each instruction.

In the following table, items in parentheses are not required when inputting the program in C mode, but are required when inputting in CV mode.

Instruction	Symbol	Function key inputs	Mnemonic inputs	Remarks
OUT		F9 <i>Bit_address</i> CR	O U T _ <i>Bit_address</i> CR	—
OUT NOT		Shift+F9 <i>Bit_address</i> CR	O U T _ N O T _ <i>Bit_address</i> CR	OR NOT can also be input using the Slash (/) Key: F9 / <i>Bit_address</i> CR .
TIMER	TIM	Shift+F5 <i>Timer_number</i> CR (CR) # SV CR or Shift+F5 <i>Timer_number</i> CR (CR) Word_address CR	T I M _ <i>Timer_number</i> _ # SV CR or T I M _ <i>Timer_number</i> _ Word_address CR	To enter a constant as the SV, input #SV. To set the SV from a word, enter the word address only.
COUNTER	CNT	Shift+F6 <i>Counter_number</i> CR (CR) # SV CR or Shift+F6 <i>Counter_number</i> CR (CR) Word_address CR	C N T _ <i>Counter_number</i> _ # SV CR or C N T _ <i>Counter_number</i> _ Word_address CR	—
Advanced instruction	—	F10 <i>Function_code</i> CR (CR) Operand CR (CR) Operand CR (CR) Operand CR	<i>Instruction</i> _ <i>Operand</i> _ <i>Operand</i> _ <i>Operand</i> CR	Input leading zeros for the function code. The number of operands varies according to the instruction.
Immediate update instructions	!	OUT/OUT NOT: <i>Instruction</i> <i>Bit_address</i> Shift+F10 CR Advanced instruction: <i>Instruction</i> Shift+F10 CR (CR) (Operand CR (CR)) Operand CR	<i>Instruction</i> _ (<i>Operand</i> _) <i>Operand</i> Shift+F10 CR	Applicable only to OUT, OUT NOT, KEEP(011), DIFU(013), DIFD(014), SET(016), RSET(017), CMP(020), and MOV(030).
Differentiate up instructions	j	<i>Instruction</i> Shift+F3 CR (CR) (Operand CR (CR)) Operand CR	<i>Instruction</i> _ (<i>Operand</i> _) <i>Operand</i> Shift+F3 CR	—
Differentiate down instructions	i	<i>Instruction</i> Shift+F4 CR (CR) (Operand CR (CR)) Operand CR	<i>Instruction</i> _ <i>Operand</i> Shift+F4 CR	Applicable only to SET(016) and RSET(017) only

Note The second of each pair of carriage returns is not required when inputting the program in C mode, but is required when inputting in CV mode.

Bit/Word Addresses and Data

Data area prefixes may be input as either upper- or lower-case characters. If an incorrect number is entered, press the Home Key and re-enter the value. It is not necessary to input leading zeros for addresses or SVs.

I and Q are displayed only after an I/O table is registered.

Refer to the CV500/CV1000 Operation Manual: Ladder Diagrams for information on using data registers and index registers (DR and IR).

Item	Bit address	Word address	Display on ladder diagram
Auxiliary Area	A <i>Bit_address</i>	A <i>Word_address</i>	A
CIO Area	<i>Bit_address</i>	<i>Word_address</i>	I: Input Q: Output
Counter Area	C <i>Counter_number</i>	C <i>Counter_number</i>	C
Constant	—	# <i>Value</i>	#
CPU Bus Link Area	G <i>Bit_address</i>	G <i>Word_address</i>	G
Data register	—	D R <i>Number</i>	DR
DM Area	—	D <i>DM_address</i>	D
EM Area	—	E <i>EM_address</i>	E
Index register	—	I R <i>Number</i>	IR
Indirect DM address	—	* D <i>DM_address</i>	*D
Indirect EM address	—	* E <i>EM_address</i>	*E
Step Area	S T <i>Step_number</i>	—	ST
Timer Area	T <i>Timer_number</i>	T <i>Timer_number</i>	T
Transition Area	T N <i>Transition_number</i>	—	TN

Examples

Basic Instructions

An example for inputting basic instructions is given below starting with a cleared ladder programming screen.

- 1, 2, 3...** 1. Press (F7,) 1, and Enter.

It is not necessary to input leading zeros for bit addresses.



2. Press Shift+F5, 10, Enter, (Enter,) #100, Enter.

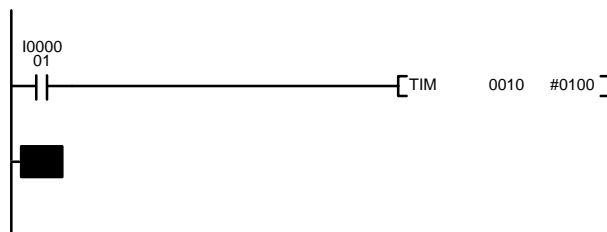

3. Press (F7,) T10, and Enter.

To designate timer or counter Completion Flags, input T or C followed by the timer or counter number.

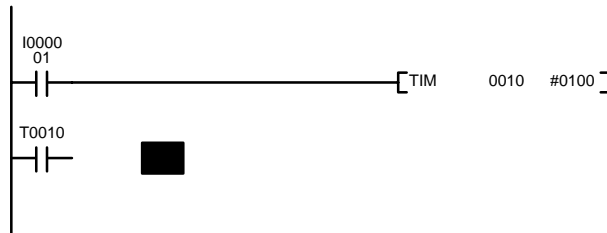

4. Press F9, 12800, and Enter.

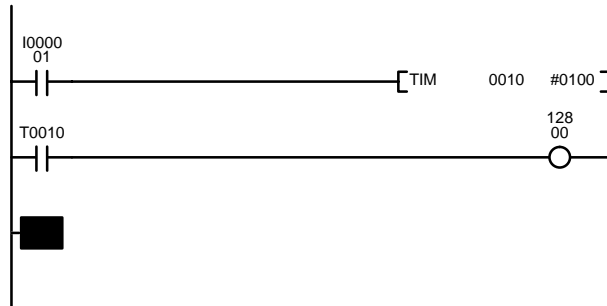

5. Press F3 and Enter to store the program.

Using Function Codes

An example for inputting a ladder program using a function code is given below starting with a cleared ladder programming screen.

1, 2, 3... 1. Press F7, 1, and Enter.

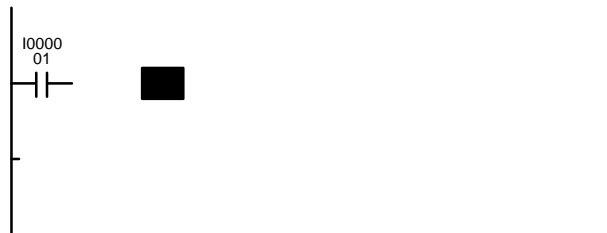

2. Press F10, 030, Enter, (Enter,) 200, Enter, (Enter,) G50, and Enter. Input leading zeros for function codes.

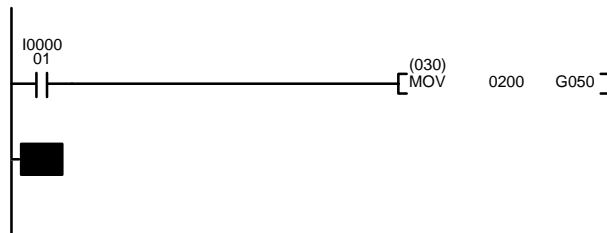

3. Press (F7,) G5, and Enter.

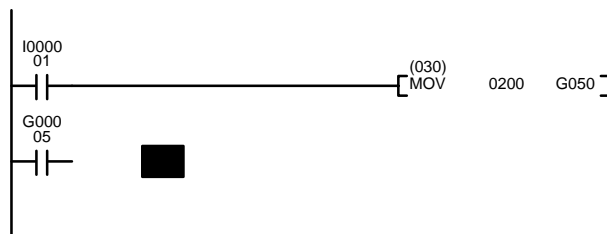

- To input the MOVE instruction via its mnemonic, press MOV, G200, 300, and Enter.

When inputting a mnemonic, press the Space Key to separate the mnemonic from operands and operands from operands.

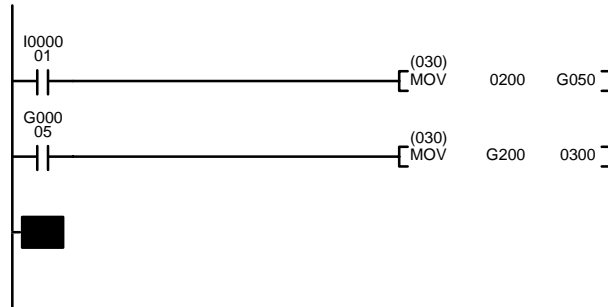

- Press F3 and Enter to store the program.

Writing and Deleting Connections

The operations shown in the following table can be used to write/delete vertical connections and connections between symbols.

Connection	Key sequence	Function
Horizontal line	Shift+F1 CR	Creates a horizontal line the size of one condition.
Vertical line	Shift+F2 CR	Creates a vertical line the size of one instruction line.
Line connect	F6 (or Ctrl+L) (move cursor to start point) CR (move cursor to end point) CR	Makes long horizontal lines to connect one instruction line or to connect an instruction line to a vertical line from another instruction line. After completing the line connections, press the Esc Key or Shift+Esc Keys to cancel the line connection mode.
Line delete	F6 (or Ctrl+L) (move cursor to start point) CR (move cursor to end point) Del	Deletes long horizontal lines and vertical connections over more than one line. After completing the line deletion, press the Esc Key or Shift+Esc Keys to cancel the line connection mode.

Note Connections cannot be made for more than 22 instruction lines (the maximum number permitted in an instruction block).

Example of Line Connections

Using the Shift+F1 Keys

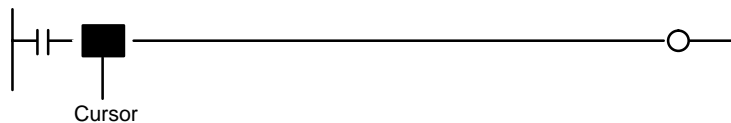

To connect horizontal spaces, move the cursor to the space and press the Shift+F1 and Enter Keys. One space is connected each time the Shift+F1 Keys are pressed.

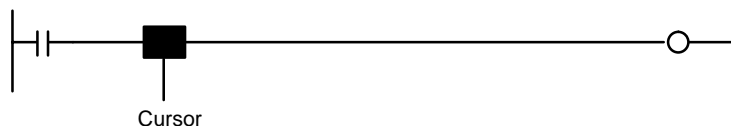

Using the Shift+F2 (|) Keys

OR LD Instructions

To connect lines vertically to create an OR LD instruction, move the cursor to the

bottom-right of the desired connection point and press the Shift+F2 and Enter Keys.

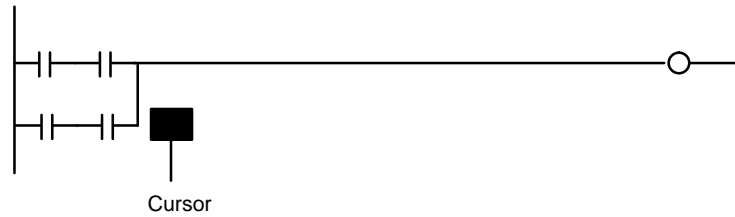
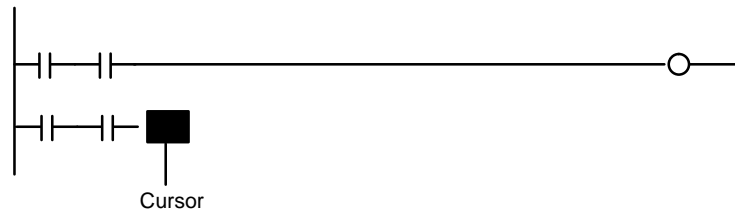

Connecting Instructions in Parallel

Press Shift+F2 and Enter.

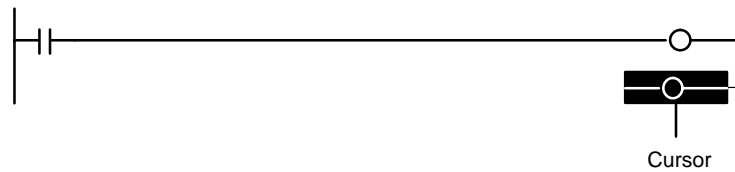

Using Line Connection Operations

After completing the line connection operations, press the Esc Key or Shift+Esc Keys to cancel the line connection mode.

Horizontal Connection

The Line Connect operation is convenient for making long horizontal connections.

- 1, 2, 3... 1. Press the F6 or Ctrl+L Keys.



- 2. Move the cursor to the start of the connection and press the Enter Key.



3. Move the cursor to the end of the connection and press the Enter Key.



Connecting Instructions Line

The Line Connection operations can also be used to connect a vertical line from another instruction line.

1, 2, 3... 1. Press F6 or Ctrl+L.



2. Move the cursor to the start of the connection and press the Enter Key.

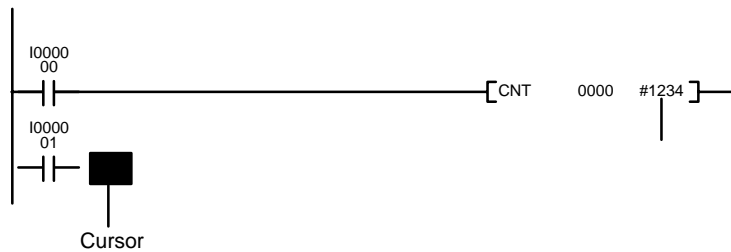

3. Move the cursor to the end of the connection and press the Enter Key.

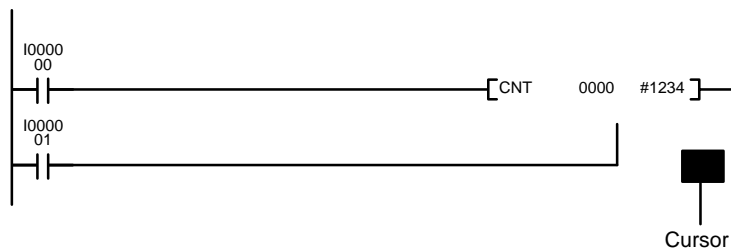

Connecting Multiple Inputs

1, 2, 3... 1. Press F6 (or Ctrl+L).



2. Move the cursor to the start of the connection and press the Enter Key.



3. Move the cursor to the end of the connection and press the Enter Key.

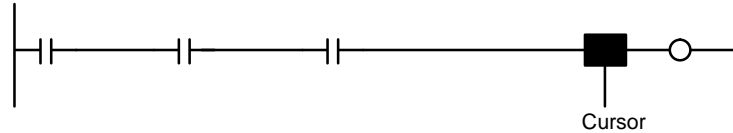

Continue Operation

The continue operation is used to continue an instruction line when the maximum number of conditions already exists on an instruction line.

Up to 9 conditions and 1 OUT instruction can be connected in a single line. Fewer instructions can be written if operands are required, such as for TIM and advanced instructions. If all required instructions cannot be written in a single line, use the continue operation to link it to the next line.

The number of inputs permitted on any line depends on the number of operands in the instructions. The limits are summarized in the following table. Here, only operand placed directly on the instruction line are counted; the operand bits for conditions are not counted.

Number of operands	Conditions per line	Comments
0	9	Plus OUT
1	7	—
2	5	—
3	4	—

Example

The following procedure shows how to add a condition (000010) as the 10th condition in the instruction line.

- 1, 2, 3... 1. Move the cursor to the 10th column (extreme right). The continue operation can only be used when the cursor is in the 10th column.

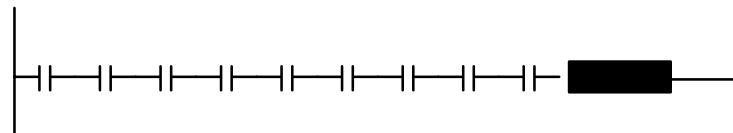

2. Press (F7,) 10, and Enter to enter the condition. The continue operation symbols will be displayed and the conditions in columns 9 and 10 will be displayed on the next line.

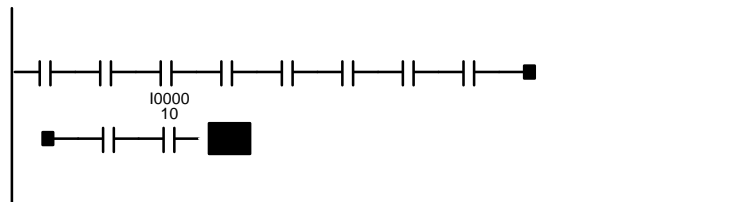

Note A program error will occur if lines are connected with the Line Connect operation, as shown in the following diagram. Use the continue operation instead.

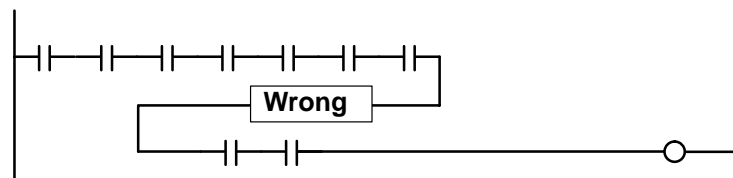

Example

The following procedure shows how to enter six conditions for a MOVE instruction.

- 1, 2, 3... 1. Enter the six conditions. Move the cursor to the 10th column (extreme right). The continue operation can only be used when the cursor is in the 10th column.

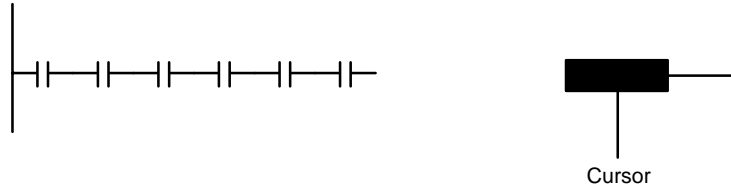

2. Press the Shift+F1 Keys to make a horizontal connection. The continue operation symbols will be displayed and the cursor will move to the next line.

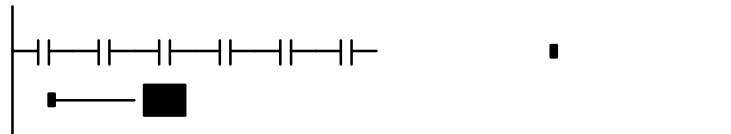

3. Press F10, 030, Enter, (Enter,) 0, Enter, (Enter,) 1, and Enter to enter a MOVE instruction.

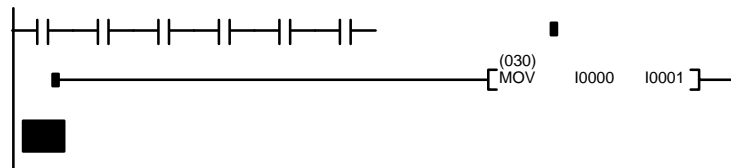

4. Move the cursor to the space in the top line and use the F6 Key to join the line.

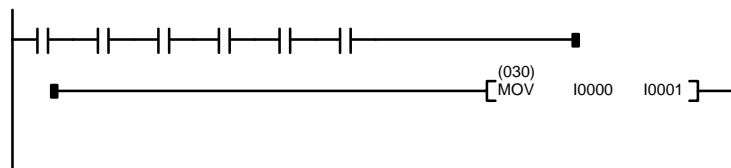

Editing Ladder Programs

The procedure for editing a ladder program is described below. Ladder programs can be edited either in the Write or Insert modes. Do not forget to store the edited program.

See 3-7 *Editing Instruction Blocks* for details on moving, copying, and deleting instruction blocks.

See 3-8 *Changing Addresses* for changing bit or word addresses in the entire program in a single operation.

Editing in Write Mode

Operation	Key sequence	Comments
Clearing data from input area	Home (or re-input the symbol)	—
Creating a Blank Column	Move cursor Ins	A blank column is created at the cursor position. If an instruction block contains more than one line, a blank column is created at the cursor position in every line of the instruction block.
Creating a Blank Line	Move cursor PgUp	A blank line is created at the cursor position. No blank line can be created if the program already contains 22 instruction lines.
Deleting a Blank Column	Move cursor Del	The blank column at the cursor position is deleted. If an instruction block contains more than one line, the blank column is deleted at the cursor position in every line of the instruction block at the cursor position. The delete operation will be cancelled unless a blank column exists at the cursor position in every line of the instruction block.
Deleting a Blank Line	Move cursor PgDn	The blank line at the cursor position is deleted. The deleted operation will be cancelled if the line at the cursor position contains ladder elements, including any instructions.
Deleting all 22 program lines of the ladder diagram	Shift+Home	—
Deleting the symbol at cursor position	Deleting a condition, instruction, or horizontal connection: Move cursor Space Key	The cursor position becomes blank. Edit as required to complete the program. Vertical connections cannot be deleted by this method.
Deleting the symbol to left of cursor	Deleting a condition, instruction, or horizontal connection: Move cursor Backspace Deleting a vertical connection: Shift+F2 Backspace	The symbol to the left of the cursor will be deleted. Edit as required to complete the program. To delete a righthand instruction, place the cursor on the far left of the same instruction line and press the Backspace Key.
Inserting a symbol	Move cursor Ins Insert symbol <i>Bit_address</i> CR	The cursor position goes blank and a symbol is entered.
Reversing normally open and normally closed conditions	Move cursor / CR	The condition at the cursor will change from normally open to normally closed or from normally closed to normally open.

Editing Examples

Changing a Bit Address

In this example, the bit address is changed from 000100 to 000300 in the following program.

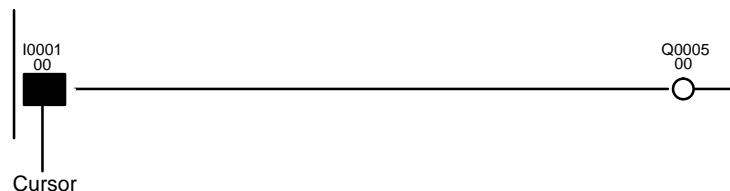

Press Enter, 300, and Enter.

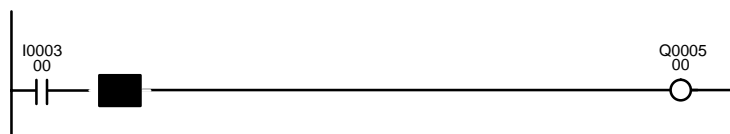

Inserting a Symbol

In this example, another condition (bit address: 000001) is inserted in the following program.

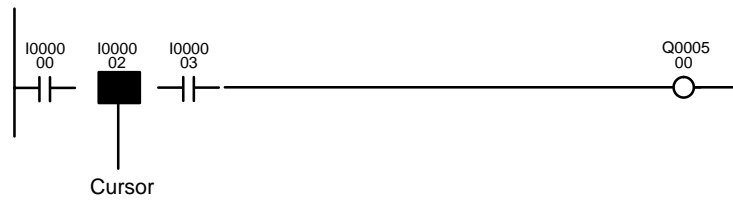

1, 2, 3... 1. Press Ins.

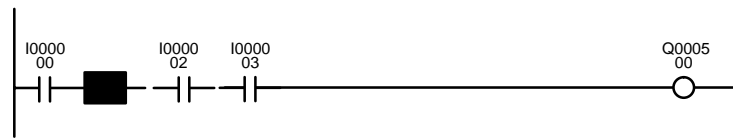
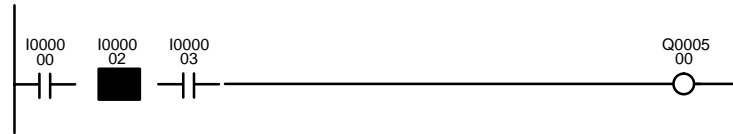

2. Press F7, 1, and Enter.

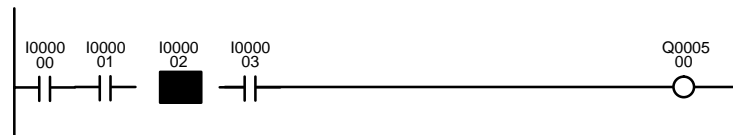

Deleting a Vertical Connection

In this example, the vertical connection in the OR LD instruction is deleted from the following program.



Press Shift+F2 and Backspace.

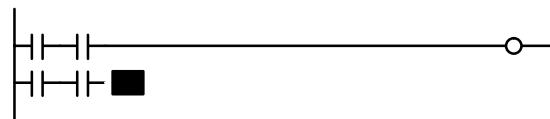

Deleting the Symbol at the Cursor Position

In this example, the symbol at the cursor position is deleted from the following program.

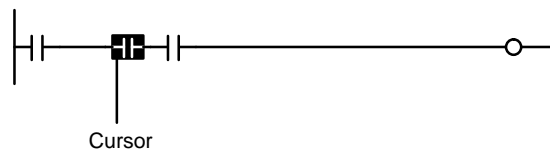

Press the Space Key.

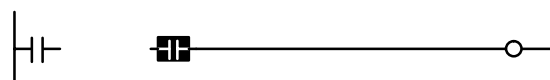

Creating and Deleting a Blank Column

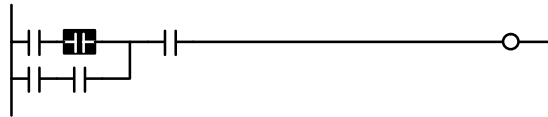

Press Ins. A blank column will be created.

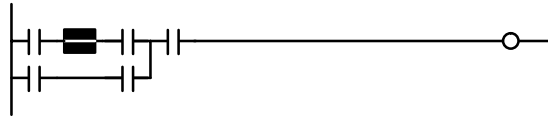

Press Del. The blank column will be deleted.

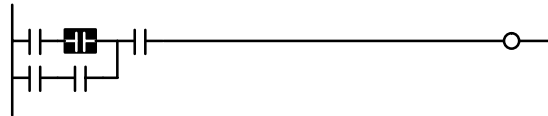

Creating and Deleting a Blank Line

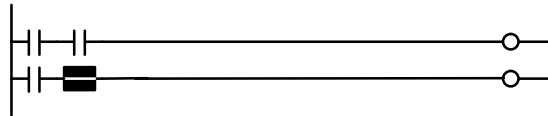

Press PgUp. A blank line will be created.

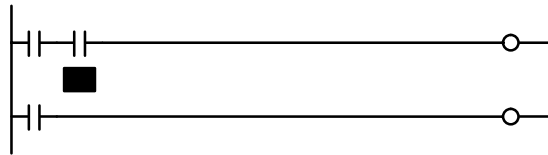

Press PgDn. The blank line will be deleted.

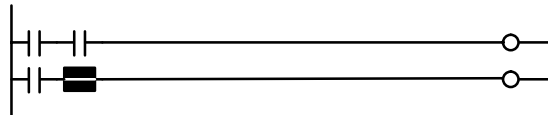

Reversing Normally Open and Normally Closed Conditions

Move the cursor to the condition to be changed

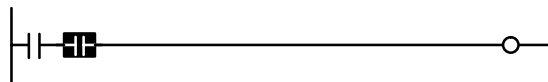

Press the / Key and Enter.

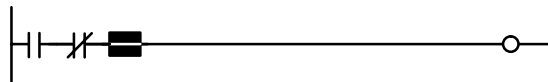

Editing in Insert Mode

Editing operations are identical to the Write Mode, however, to save pressing the F2 Key to switch modes, it is more convenient to edit in the Write Mode. The methods to create and delete lines and columns are identical to the Write Mode. The procedure to insert symbols is described below.

Item	Key sequence
Inserting a symbol	F2 (Insert Mode) Move cursor <i>Symbol</i> <i>Bit_address</i> CR

Advantages of the Insert Mode

As the editing operations in the Insert mode simply duplicate those in the Write mode, they are seldom used. However, as it is not necessary to press the Insert Key once for each symbol, the Insert mode may be more convenient when consecutively inserting a large number of symbols.

3-5-2 Store/Store Insert

These operations are used to write a ladder program created on the screen to the work disk. Use the Store or Store insert operations before the ladder program exceeds 22 lines (the maximum number permitted in a program section).

Ladder programs created on the screen but not saved with the Store or Store insert operations may be lost when menus are switched, the reset switch is pressed, or the POWER switch is turned off.

Item	Key sequence	Comments
Store	F3 CR	Writes the ladder program section created on the screen (with a maximum of 22 instruction lines) to the work disk. A message will flash to indicate that the program is being stored. After the program is stored, the screen will return to the Write mode and the next address will be displayed. The addresses of each instruction is fixed when the program is stored. The addresses will be displayed again the next time the program is read. After a program section is read, edited and stored, only the edited version of the program section is stored on the work disk.
Store insert	F4 CR	Writes the ladder program section created on the screen (with a maximum of 22 instruction lines) to the work disk in front of the previously read program section. The previous program section remains unchanged on the work disk, behind the new, inserted program section. A message will flash to indicate that the program is being stored. After the program is stored, the screen will return to the Write mode and the next address will be displayed.

Store vs Store Insert

The store operation is used to write a new ladder program section to disk when editing program sections stored on the work disk. The store insert operation is

also used to insert an unchanged or partially edited program section on the work disk in front of its original position.

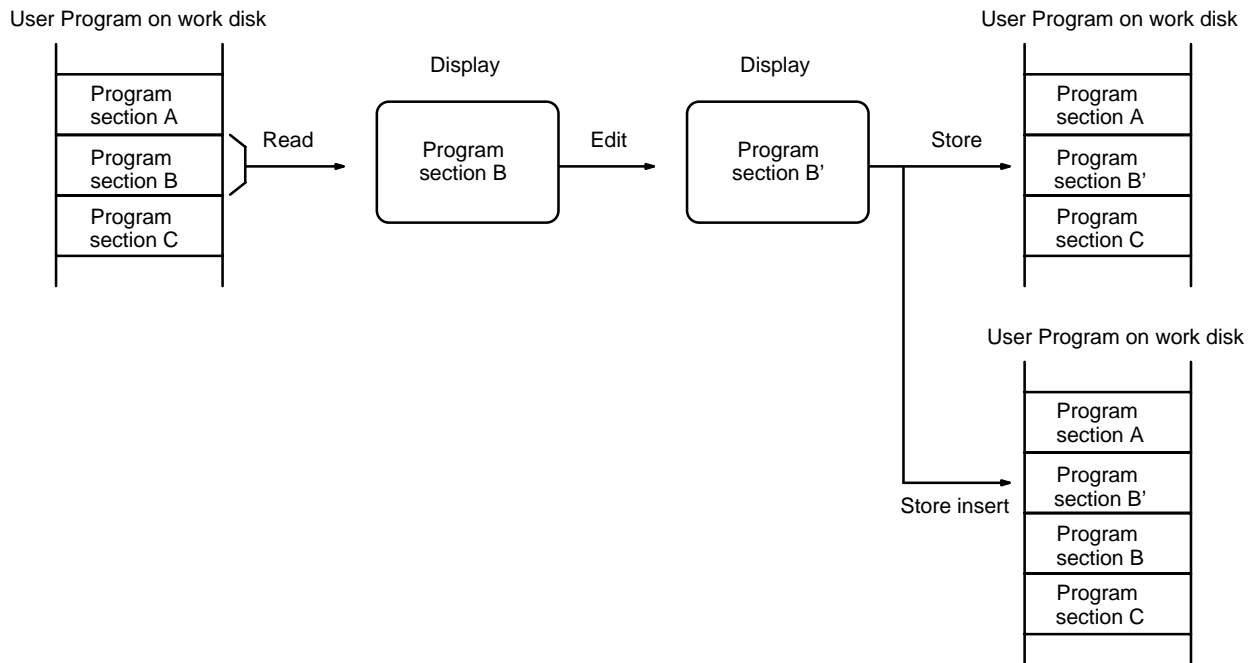

A program section read from disk then deleted on the screen will be permanently lost if the store operation is used to write it back to the work disk. Take particular care in cases like the example below, where several program sections are read and deleted on screen and another program section is created. When the new program section is stored to the work disk, the program sections read originally will all be permanently lost. They would not be lost if the store insert operation was used.

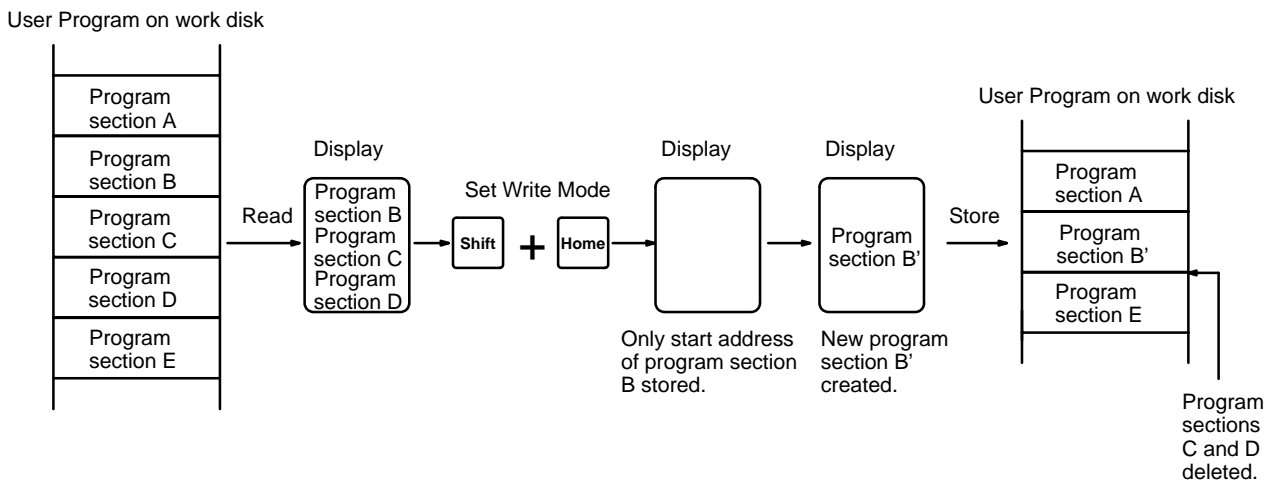

Program Sections Not Applicable to Store/Store Insert

An error message will be displayed and the store/store insert operation cancelled if an attempt is made to use the store/store insert operations with an incorrect program section or one which cannot be processed by the CVSS. Correct and edit the program section if this problem occurs.

Incomplete Instruction Lines

a) No righthand instruction

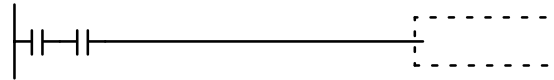

b) Broken connection

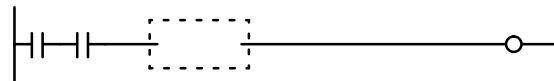

c) Instruction line not entered for an execution condition

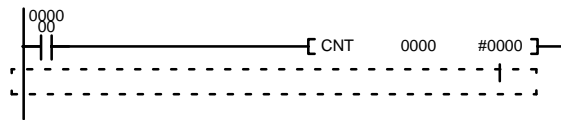

d) Surplus line

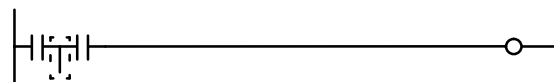

e) No conditions on an instruction line

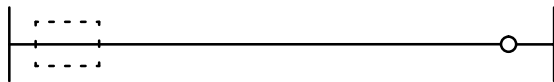

f) Short-circuited conditions

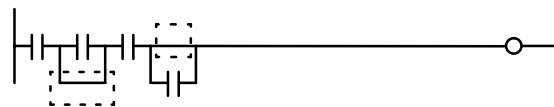

g) Instruction line doubles back

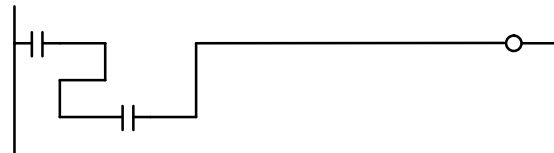

Program Sections CVSS Cannot Process

Correct the program sections on the left as shown on the right for each of the following pairs.

a) Horizontal line in front of OR instruction with no condition on the line. Conditions must be aligned on the left.

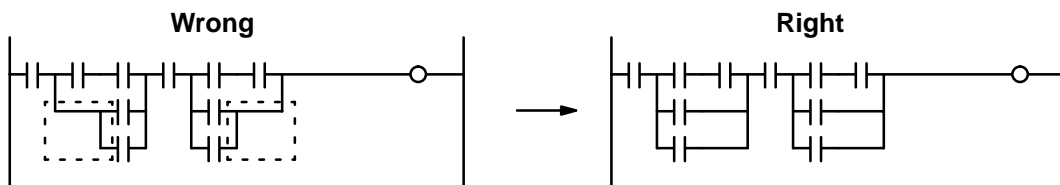

b) AND and OR instructions inside OR instruction. Move AND and OR to the bottom of the OR.

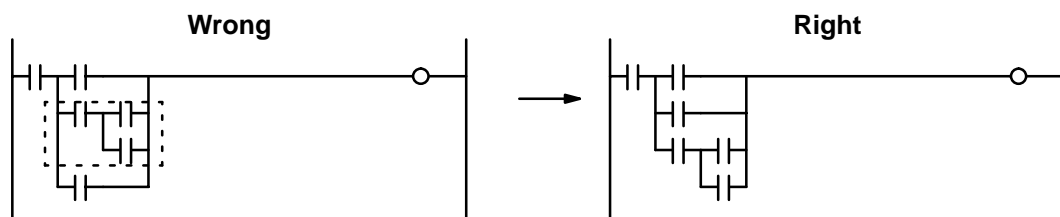

c) More than 8 LD instructions used.

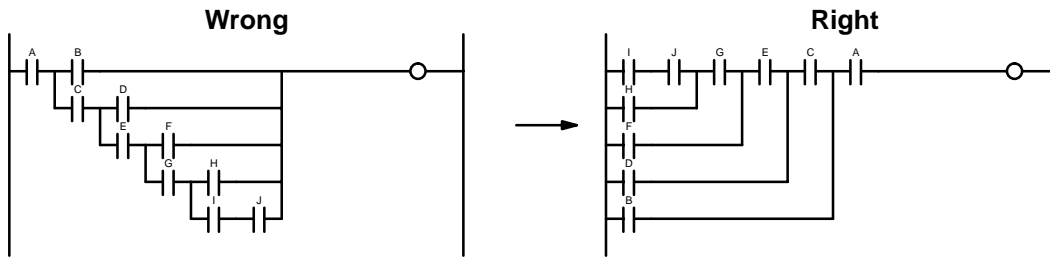

d) Multiple continue operations. Do not use continue operations in parallel.

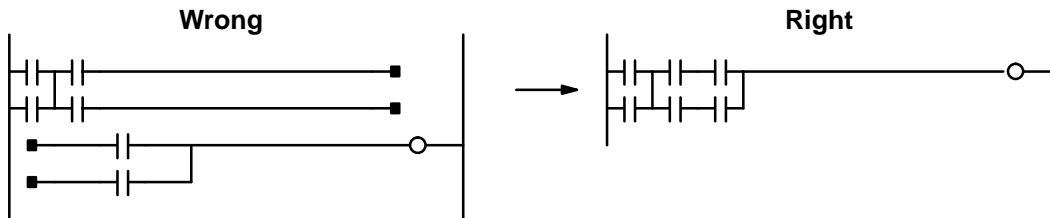

e) Continue operation in second, or lower, line of an OR program section. Move the continue operation to the top line.

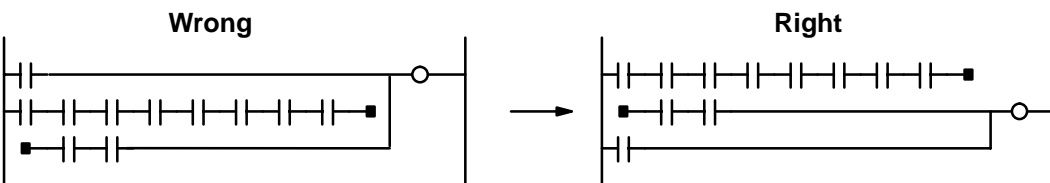

f) Branching continue operation or OR program section. Eliminate branching from circuit.

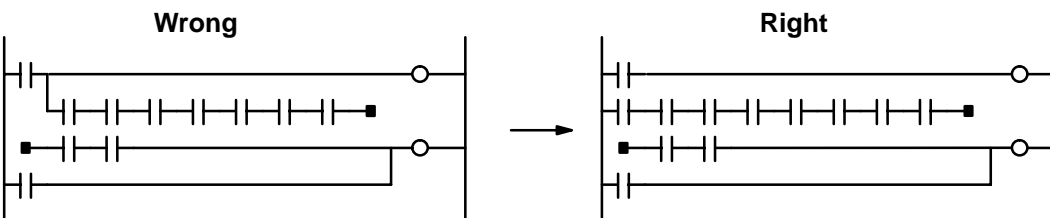

3-5-3 Reading and Searching Ladder Diagrams

The following operation is used to read the program from the work disk and display it on the screen as a ladder diagram.

Press the F1 Key to switch to Read mode from the Write or Insert mode.

Ladder Read Screen

The read mode will be displayed at the top-right of the screen.

Press the F1 to F10 Keys to select items from the function key menu displayed at the bottom of the screen.

Press the Shift Key to change the function key menu.

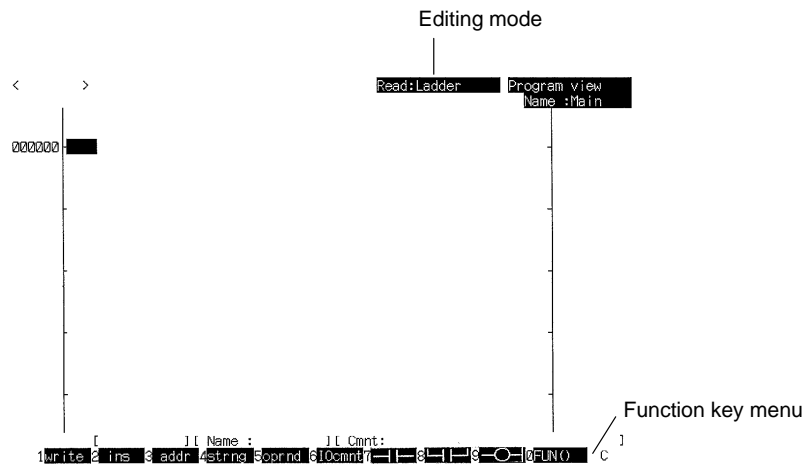

Function Keys in the Read Mode

Function Key	Display	Function	Page
F1	write	Selects the write mode.	77
F2	ins	Selects the insert mode.	89
F3	addr	Reads from a specified program address.	96
F4	strng	Finds a specified mnemonic (written instruction). Operands can also be found.	98
F5	oprnd	Finds a specified operand or I/O name.	98
F6	IOcmnt	Finds a specified operand or I/O comment.	99
F7		Finds a condition from a specified bit address. Finds the following: LD, AND, OR.	97
F8		The functions of F7 and F8 are identical.	
F9		Finds an OUTPUT instruction from a specified bit address. Finds the following: OUT.	95
F10	FUN ()	Finds an instruction from a specified function code.	98
Shift+F2	blk cm	Finds a specified block comment.	99
Shift+F3	DIFU	Finds only the differentiate up variation of the specified instruction.	—
Shift+F4	DIFD	Finds only the differentiate down variation of the specified instruction.	—
Shift+F5	TIM	Finds a specified timer instruction.	95
Shift+F6	CNT	Finds a specified counter instruction.	95
Shift+F7		Finds a condition from a specified bit address. Finds the following: LD NOT, AND NOT, OR NOT.	—
Shift+F8			
Shift+F9		Finds an OUTPUT instruction from a specified bit address. Finds the following: OUT NOT.	—
Shift+F10	!	Finds only the immediate refresh variation of the specified instruction.	—

Reading Ladder Programs

Follow the procedures on the following page to display the specified instruction blocks.

Operation	Key sequence	Description
Reading a specified program address	F3 Address CR	It is not necessary to input leading zeros, e.g., input address 00000 as 0. The instruction block containing the specified address will be displayed on the screen.
Finding a specified condition or output	Specifying an input: F7 Bit_address CR Specifying an output: F9 Bit_address CR	It is not necessary to input leading zeros. Finds and reads the following conditions: LD, LD NOT, AND, AND NOT, OR, OR NOT. Finds and reads the following output: OUT, OUT NOT. F8, SHIFT+F7, or SHIFT+F8 can be used in stead of F7. SHIFT+F9 can be used in stead of F9.
Finding a reciprocal condition/output	Move cursor to desired condition/output CR	Select a condition or output with the cursor to find the corresponding output or condition. If LD, LD NOT, AND, AND NOT, OR, or OR NOT is specified, the OUT or OUT NOT with the same bit address will be found. If OUT or OUT NOT is specified, the LD, LD NOT, AND, AND NOT, OR, OR NOT with the same bit address will be found.
Finding timer instructions	Shift+F5 Timer_number CR	It is not necessary to input leading zeros of the timer or counter number.
Finding counter instructions	Shift+F6 Counter_number CR	
Finding an instruction from its function code	Instructions executed every cycle: F10 Function_code CR Differentiate up/down instructions or immediate update instructions: F10 Function_code CR Shift+F3 (or Shift+F4 or Shift+F10) CR	Input leading zeros of the function code. While the prompt FUN(???) is displayed, press the Enter Key or the Ctrl+F Keys to display a table of instructions. Select the required instruction with the cursor and press the Enter Key. The selected instruction will be displayed at the bottom of the screen. Press the Enter Key to start the search.
Finding instructions containing operands	F4 Mnemonic _ Operand _ Operand _ Operand CR	Enter the mnemonic in upper-case or lower-case letters. Press the Space Key to separate mnemonics from operands and operands from operands. Input leading zeros of the function code. Press the ? Key as a wildcard to omit operands, for example: MOV ? 0.
Finding instructions from an operand	F5 Operand CR	Specify operands as a bit address or word address. Input leading zeros of the bit address. Only one operand can be specified.
Finding an I/O name	F5 I/O_name CR	Finds the I/O name starting with the specified string.
Finding an I/O comment	F6 I/O_comment CR	Finds the I/O comment of a bit or word address. Finds the I/O comment starting with the specified string.
Finding a block comment	Shift+F2 Block_comment CR	Finds the block comments starting with the specified block string.

Finding Instructions

After specifying the read or find operation as described in the previous table, follow the procedure below.

- 1, 2, 3... 1. Press the Enter Key to start searching from address 00000.
During the operation, a message will flash at the top-right of the screen.
When the specified condition or instruction is found, the instruction block it is contained in will be displayed. If an instruction line consisting of more than

22 lines is read, the display mode will automatically switch to mnemonic. Switch the display mode back to a ladder mode before displaying the next instruction block.

2. Press the Enter Key to repeat the search.

When the search of the final area is complete, one of the messages shown in the table will be displayed at the top-left of the screen.

Message	Repeating the search
Not found	Press the Enter Key to repeat the search from address 000000.
Last page	Repeat the entire procedure to find a different instruction block.

- or Press the Esc Key followed by the Tab Key to display the previously found instruction block.
- or Press the PgDn or PgUp Keys to read the instruction blocks before or after the currently displayed instruction block.
- or Press the Esc Key to cancel a read (find) operation.

Reading the Previous or Next Instruction Block

Press the PgDn or PgUp Keys to display the instruction block before or after the currently displayed instruction block.

Key	Description
PgDn	Read the next instruction block.
PgUp	Read the previous instruction block.

Scrolling Large Instruction Blocks

If the instruction block is larger than the maximum display size, press the cursor Arrow Keys to scroll through the displayed instruction block. The number of instruction lines displayed on each display is from 3 to 10, depending on the display mode.

Key	Description
Down	Press the Down Key when the cursor is on the bottom line of the screen to display the next instruction line.
Up	Press the Up Key when the cursor is on the top line of the screen to display the previous instruction line.

Note The Arrow Keys can be used only to view the current instruction block.

Example of Reading a Ladder Program

Reading a Specified Program Address

In this example, the instruction block containing address 100 is read from a program.

- 1, 2, 3... 1. Press F3, 100, and Enter. The instruction line containing program address 100 will appear.

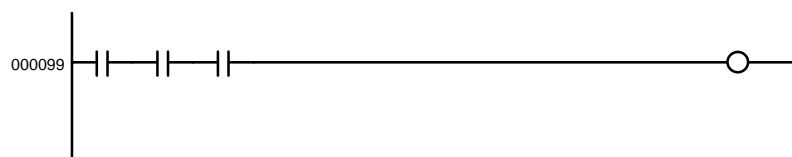

2. Press the Esc Key to end the search.

- Press the PgDn Key to display the next instruction block.
The original instruction block will remain on the screen, if space allows.

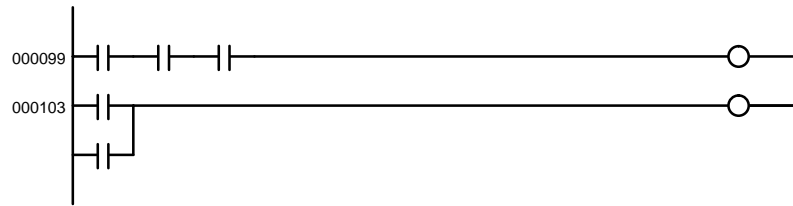

- Press the PgUp Key to display the previous instruction block.
The original instruction block will remain on the screen, if space allows.

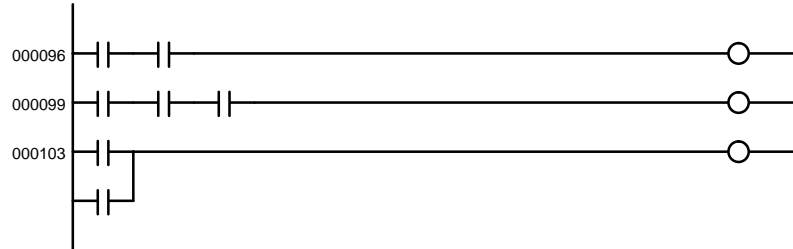

- Press the Down Key to display subsequent lines if the instruction block exceeds the maximum display size.

Finding a Specified Condition or Instruction

We'll assume the following user program is on the work disk.

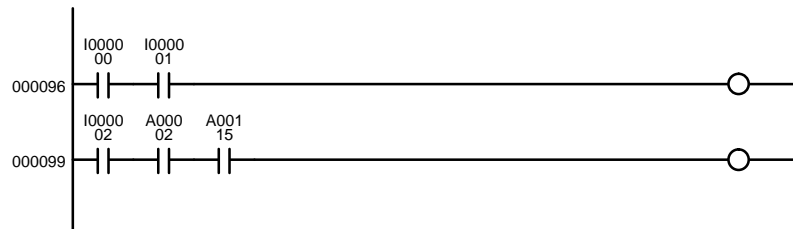

Finding LD/AND A00115

1, 2, 3...

- Press F7.
LD/AND system and an input area for the bit address or I/O name will be displayed at the bottom of the screen.

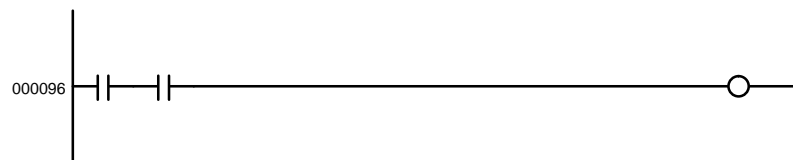

- Press A115, and Enter.
After the Enter Key is pressed, the instruction block containing the specified input will be displayed on the screen. Data area prefixes must be in capital letters.

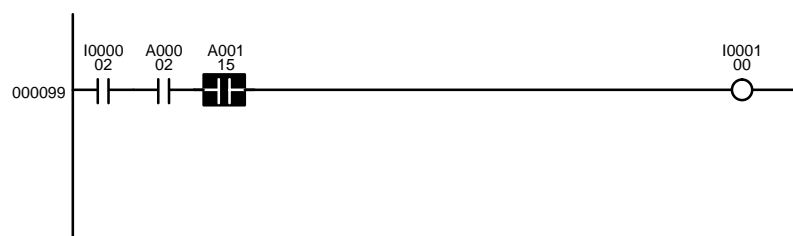

Finding MOV(030) with the Function Code

Press F10, 030, and Enter. Input all digits of the function code.

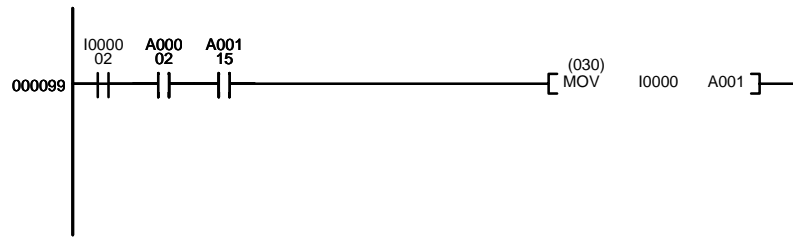

Finding the MOVE Instruction with A015 as the Second Operand

To find a specific instruction with one or more specific operands, use mnemonic searches.

Press F4, MOV, Space, ?, Space, A15. Press the Space Key to separate mnemonics from operands and operands from operands.

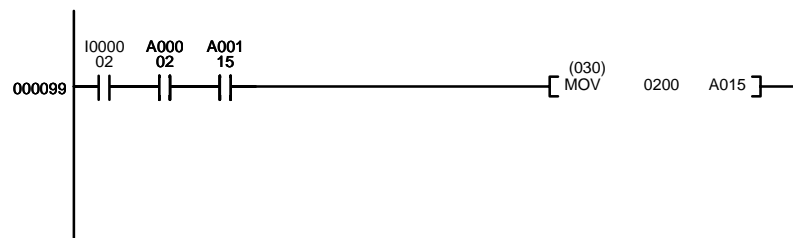

Finding a Specified Operand

When reading an instruction block with a specified operand, the input number is treated as a word address if the number of digit input is within the maximum number for a word address. If the number is beyond the maximum for a word address, the input number is treated as a bit address. Therefore, it is necessary to input all or nearly all digits of a bit address, but it is not necessary to input leading zeros for a word address, as shown in the following examples.

Address	Minimum input
Bit 000001	00001
Word 0001	1

Finding Bit G00800

Press F5, G00800, and Enter. Input all digits of the bit address.

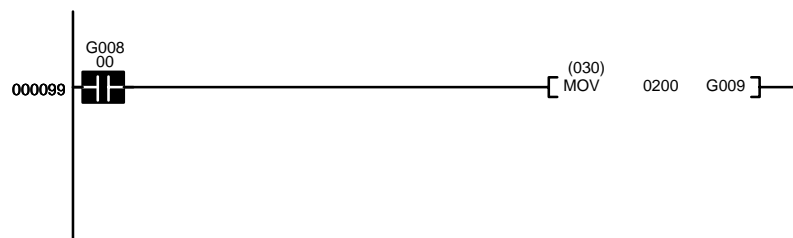

Finding Word G008

Press F5, G8, and Enter.

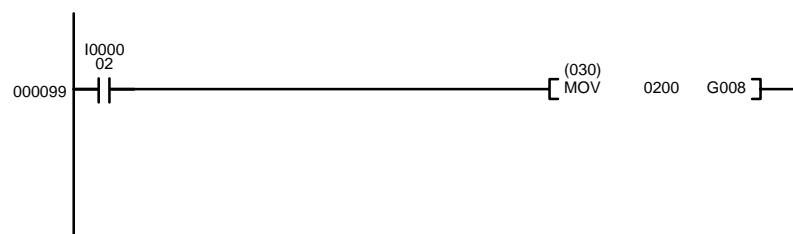

Finding Comments

Finding the I/O Comment “SW1”

Press F6, Caps_Lock, SW1, and Enter.



Finding the Block Comment “Manufacturing process control block”

Press Shift+F2, Menu, and Enter.

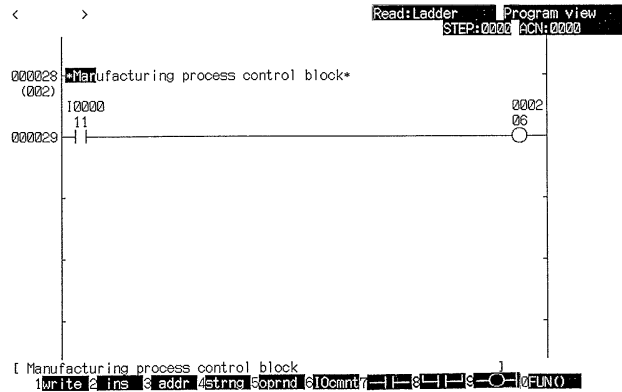

3-5-4 Including I/O Comments in Ladder Diagrams

I/O comments can be input or changed during ladder diagram input or debugging. Although I/O comments can also be input or changed using the I/O comment operation, this section described inputting them directly while inputting the ladder diagram. It makes no difference whether I/O comments are entered here or in the I/O comment operation, and all comments input while programming are automatically entered into the I/O comment table.

I/O comments will be displayed when input in the “Ladder (I/O comment 2)” (2 lines of comments) or “Ladder (I/O comment 4)” (4 lines of comments) display mode, but not in any other mode.

I/O comments can be up to 30 characters long, but only 10 characters are displayed on 2 lines of comments and only 20 characters are displayed on 4 lines of comments.

The basic procedure is as follows:

- 1, 2, 3... 1. Input “H:Change Display” from the programming menu.
2. Specify either “C:Ladder (I/O comment 2)” or “M:Ladder (I/O comment 4).”
3. If not already in the write mode, press the F1 Key.
4. Input the instructions and the I/O bit address. Example: F7, 0, CR. The I/O comment input area will appear at the lower right of the screen.
5. Input the I/O comments and press the Enter Key. Example: START, CR.

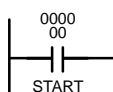

3-6 Creating Block Comments

Block comments can be created in the Ladder (Addr, I/Oname), Ladder (I/O comment 2), and Ladder (I/O comment 4) display modes. Block comments

created in the Ladder (Addr, I/Oname) display mode can be read in any display mode. Block comments are inserted between adjacent instruction blocks. Up to 44 lines can be written in one block comment.

Each block comment is denoted with an asterisk (*) before and after it and up to 512 of these block comments can be created in a program, making a maximum total of 65,536 characters. All letters and numbers are permitted in block comments.

Always store created block comments.

Block comments can be created either in a blank line or directly after the current instruction block. Block comments are automatically inserted between the current instruction block and the next instruction block, so it is not necessary to insert a blank line before entering a block comment unless you want to insert a block comment before the current instruction block.

Procedure

- 1, 2, 3... 1. Select the Write Mode
2. Move the cursor to a blank line and press the F5 Key. Press the arrow keys to move the cursor.

An asterisk will be displayed at the start of the line.

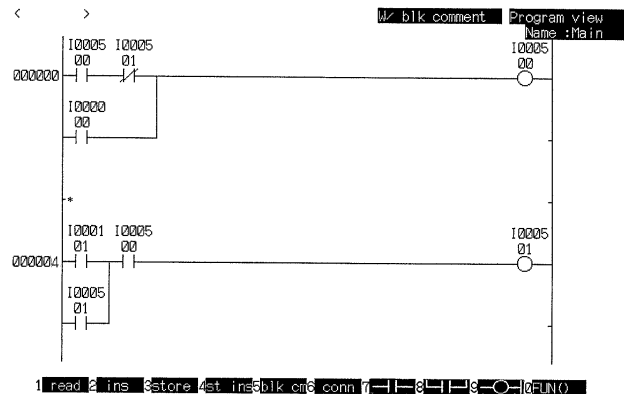

3. Write the block comment.

Refer to the *CV Support Software Version 2: Basics* for the method of entering characters.

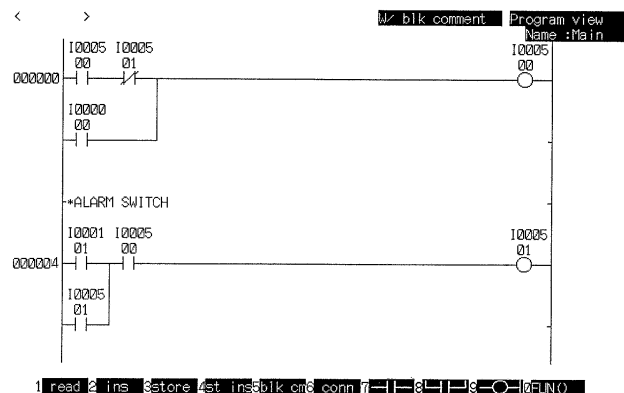

4. Press the Enter Key after the block comment is input.
An asterisk will be displayed at the end of the block comment.

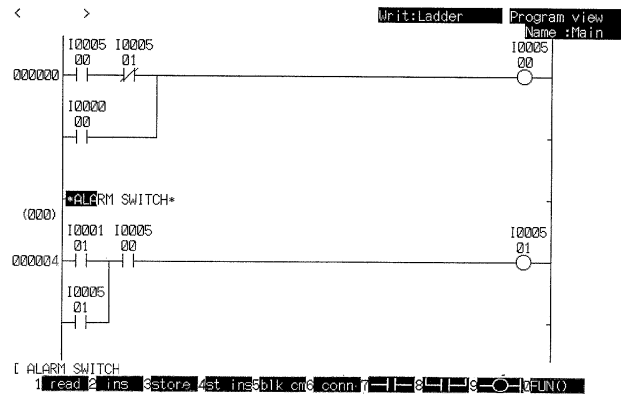

5. Press the F3 Key to store the block comment.

3-7 Editing Instruction Blocks

The following operations can be used to move, copy, or deleted instruction blocks on the work disk. The instruction block editing operations are available for programs written in ladder form only. Mnemonic programs cannot be edited with these operations.

Programs are edited directly on disk, so that it is not necessary to store edited programs.

Block comments can be moved, copied, or deleted along with the instruction lines. The editing operations treat the block comment from the first asterisk (*) displayed in the address position to the next line starting with an asterisk as a single instruction block. If no subsequent line starts with an asterisk, the entire block comment covering multiple lines is treated as the instruction block.

I/O comments and I/O names are automatically moved, copied, or deleted along with the instruction block, but they are not removed from the work disk.

Instruction Block Editing Operations

Name	Description	Function
Move		<p>Moves one or more instruction blocks.</p>
Copy		<p>Copies one or more instruction blocks.</p>
Delete block		<p>Deletes one or more Instruction blocks.</p>

Procedure

- 1, 2, 3... 1. Press the End Key or Ctrl+M Keys to access the menu.
2. Select "E:Move block" from the menu.

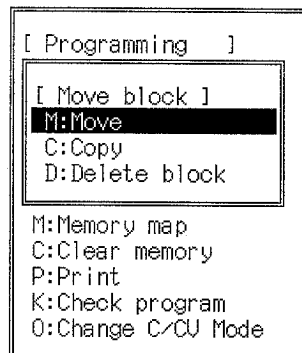

3. Select the required operation.

Input areas will be displayed at the bottom of the screen for the start, end, and destination addresses.

4. Move the cursor to each address on the screen and press the Enter Key.

Press the PgDn Key and PgUp Key to display the required instruction block and the Up and Down Keys to select the required address. The required instruction blocks can also be displayed with the find operations.

The end address must be equal to or greater than the start address. A single instruction block is selected if the start address and end address are the same. The destination address cannot lie between the specified start and end addresses.

To specify the destination address at the end of the program, display the last instruction block, press the PgDn Key so that a message at the top-left of the screen indicates that the final page is displayed, and then press the Enter Key.

3-8 Changing Addresses

The following operations are used to globally change the bit or word addresses used in a program on the work disk. The operator can also specify whether the I/O names and I/O comments are changed. The I/O comments are changed on the work disk. An operand which cannot be changed is displayed as "?????"

The following three change operations are available, each with different change capabilities. "Bit adr, T/C no." can be used to change individual CIO, Auxiliary, and CPU Bus Link Area bits or individual step and transition numbers.

(Yes: Can be changed, No: Cannot be changed)

Operation	Areas to be changed						Setting range
	I/O, A, G		TIM, CNT		ST, TN (numbers)	DM, EM (words, including indirect addr.)	
	Bits	Words	In basic instructions	In advanced instructions			
Bit adr, T/C no.	Yes	No	Yes	No	Yes	No	TIM, CNT
Wd adr, DM/EM adr	No	Yes	No	Yes	No	Yes	All
Wd adr (with bit adr)	Yes	Yes	No	No	No	No	All

Note Error messages occurring during the block change operations are displayed after the block change is complete. If more than two errors occur, only the number of errors is displayed, without the messages.

3-8-1 Changing Bit Addresses and TIM/CNT Numbers

With this operation, individual bits in the CIO, Auxiliary, and CPU Bus Link Areas or individual step or transition numbers can be changed or ranges of timer or counter numbers can be changed.

In the following example, bit 000003 is changed to timer T0010.

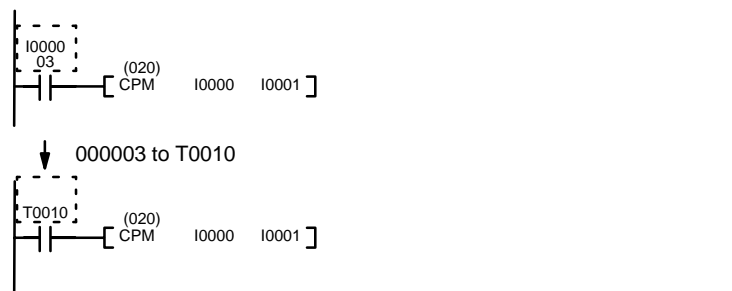

When one TIM or CNT number is changed to another, the timer/counter instruction will be changed at the same time as operands. In the following example, T0010 and all operands designated as T0010 are changed to T0030.

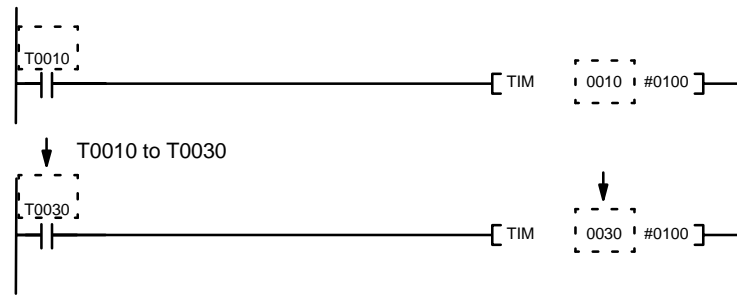

When a timer/counter number is changed to a bit address, only operands are changed. In the following example, timer T0010 is changed to C0030 and the TIM instruction remains unchanged.

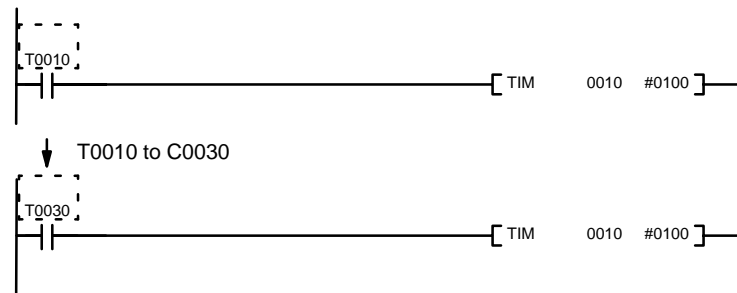

When bits or timer/counter numbers are changed, word operands (including timer/counter numbers accessing PV) are not changed.

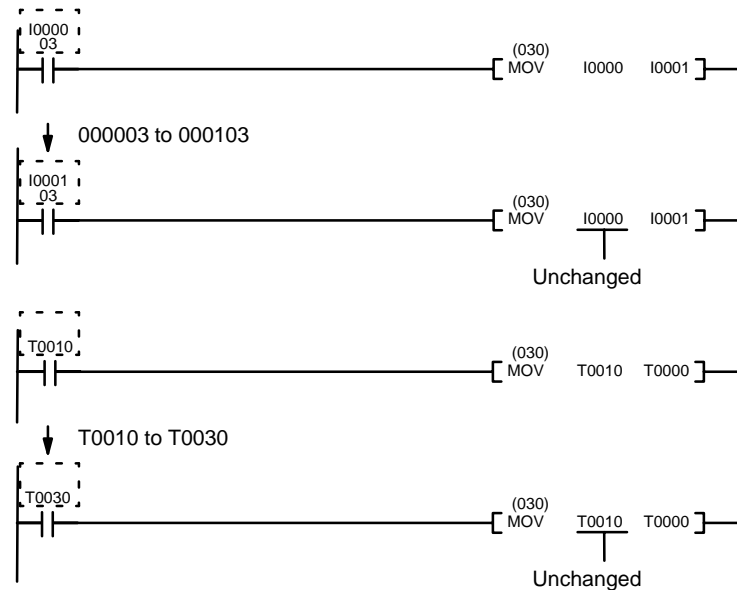

A message in the top-left of the screen will indicate if the specified address/number does not exist in the program.

Changing I/O Names

Replacements can be made based on whether an I/O name is displayed for a condition. If “Change bit addr using (with) I/O name” on the replacement subme-

nu is set to No, bit addresses will be changed only when an I/O name has not been input.

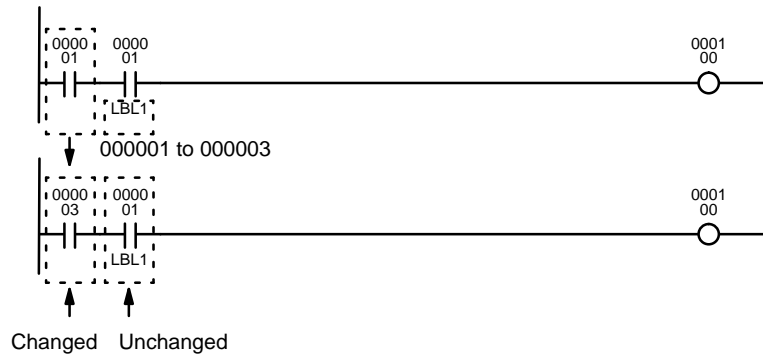

If "Change bit addr using (with) I/O name" on the replacement submenu is set to Yes, all matching bit addresses will be changed. However, if the I/O name for the bit address after the change differs from the I/O name for the bit address before the change, the I/O name will not be changed and ??? will be displayed for the bit address.

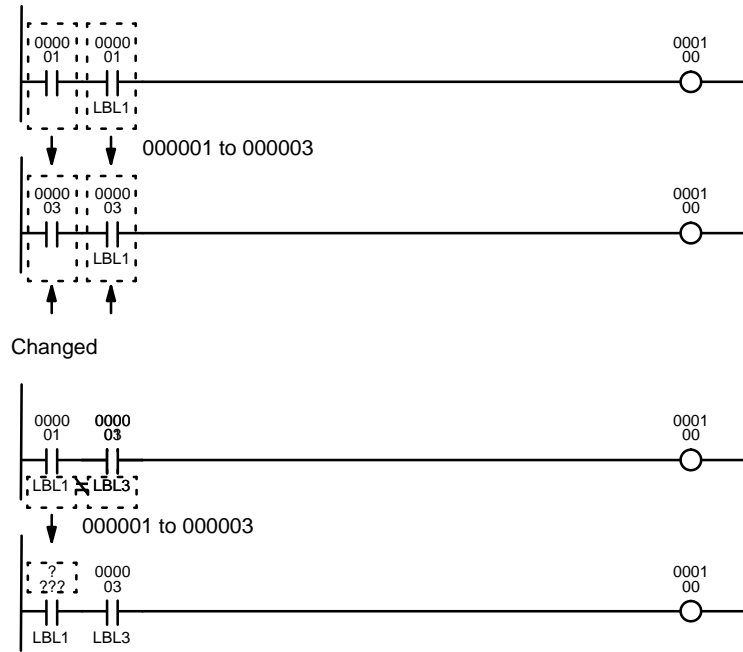

In the example, ??? is displayed as LBL1 differs from the I/O name for bit address 000003 after the change.

Changing I/O Comments

You can specify whether or not I/O comments are to be changed for replacements. If “Change I/O comment” on the replacement submenu is set to No, the I/O comment for the new bit address will be used. If the changed bit address has no I/O comment, no I/O comment will be displayed.

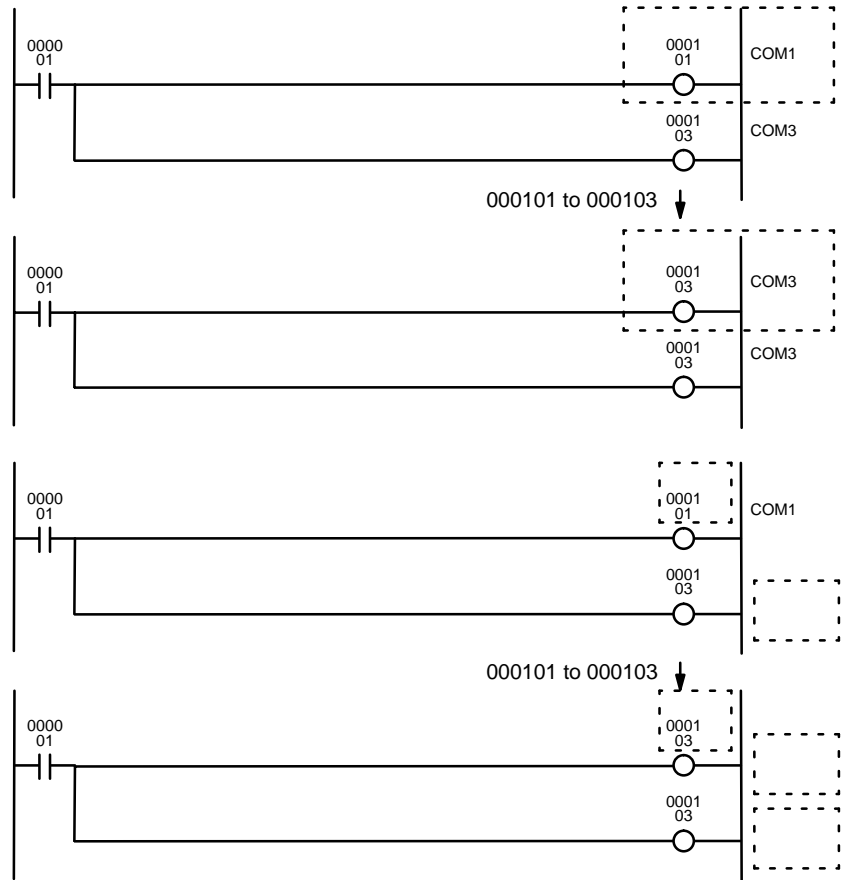

If "Change I/O comment" on the replacement submenu is set to Yes, the I/O comment for the bit address before the change will remain if the new bit address has no I/O comment. If the I/O comments differ for the bit addresses before and after the change, the I/O comment for the old bit address will be used.

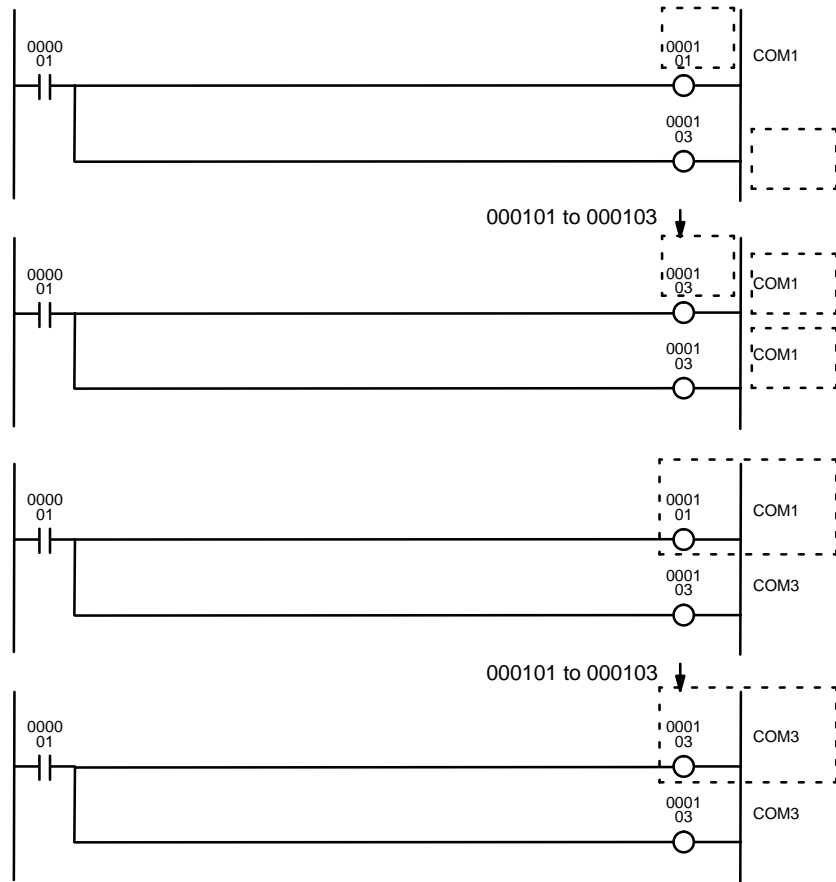

Procedure

- 1, 2, 3... 1. Select "N:Change data wd" from the menu.

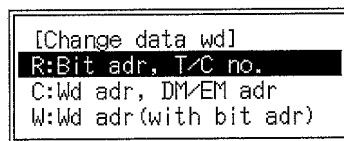

2. Select "R:Bit adr, T/C no." from the sub-menu.

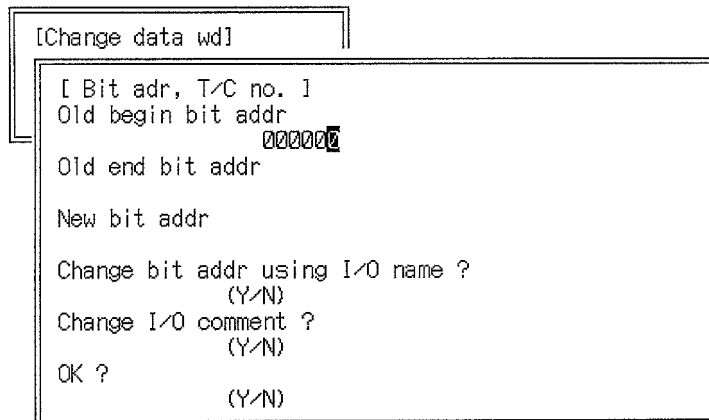

3. Enter the first address to be changed and press the Enter Key.
4. To change only one bit/number, press the Enter Key.
- or To make multiple changes, enter the last address to be changed. Multiple changes can be made for timer/counter numbers only. The first and last address must be both timer numbers or both counter numbers.
5. Enter the new bit address/number.
 - When changing multiple TIM or CNT, enter the new number for the first address.
6. Set whether or not bit addresses with I/O names are to be changed.
7. Set whether the I/O comments are to be changed.
8. Select Y at "OK?" and then to execute the change press the Enter Key in response to the confirmation message.

A message will flash to indicate that the changes are being made and the program name will be displayed. The message and program name will be cleared from the screen when the changes are complete.

3-8-2 Changing Words Addresses

Word addresses can be change in the CIO, Auxiliary, CPU Bus Link, Timer, Counter, DM, and EM Area. Multiple, consecutive words can also be changed. Individual bits cannot be changed.

For timers and counters, only timer/counter numbers accessing the PV are changed (i.e., number used as word operands. Timer/counter numbers used as bit operands and timer/counter instructions are not changed. In the following example, the only change is T0002 to T0012.

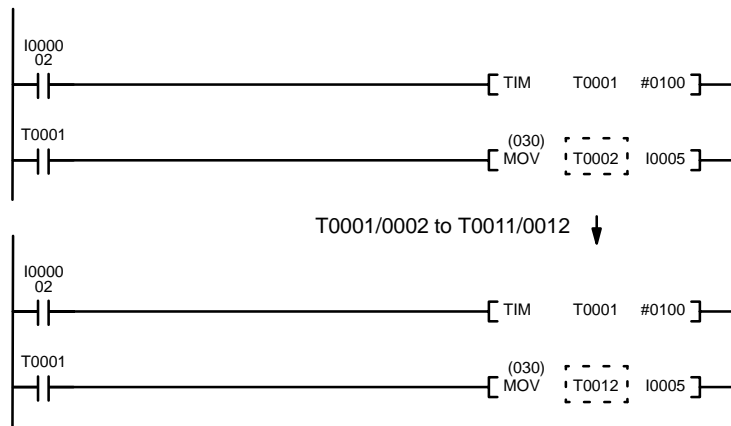

The word address can be change between data areas. In the following example, CIO 0001 is changed to D00003.

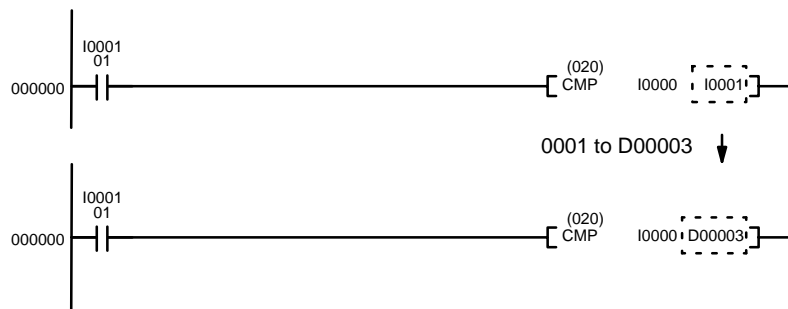

Changing I/O Names and Comments

I/O names and comments are handled the same as for when changing bit addresses. Refer to the previous section for details.

Procedure

- 1, 2, 3... 1. Select "N:Change data" from the menu.

```
[Change data wd]
R:Bit adr, T/C no.
C:Wd adr, DM/EM adr
W:Wd adr(with bit adr)
```

2. Select "C:Wd adr, DM/EM adr" from the sub-menu.

```
[Change data wd]
[ Word adr, DM/EM adr]
Old begin wd addr
Old end Wd addr
New wd addr
Change Wd addr using I/O name ?
(Y/N)
Change I/O comment ?
(Y/N)
OK ?
(Y/N)
```

3. Enter the first address to be changed and press the Enter Key.

4. To change only one word, press the Enter Key.

- or To make multiple changes, enter the last address to be changed.

The start and end word address must be in the same data area, and the end address must be greater than the start address.

5. Enter the new word address.

When changing multiple words, enter the new address for the first address.

6. Set whether or not bit addresses with I/O names are to be changed.

7. Set whether the I/O comments are to be changed.

8. Select Y at "OK?" and then to execute the change press the Enter Key in response to the confirmation message.

A message will flash to indicate that the changes are being made and the program name will be displayed. The message and program name will be cleared from the screen when the changes are complete.

3-8-3 Changing Words and Bit Address Together

This operation can be used to change all word and bit addresses for specified words. Changes can be made in the CIO, Auxiliary, and CPU Bus Link Areas only. Words can be changed to addresses in different data areas.

Multiple, consecutive words can also be changed.

In the following example, CIO 0001 is changed to G008, and as a result, CIO 000101 is also changed to G00801.

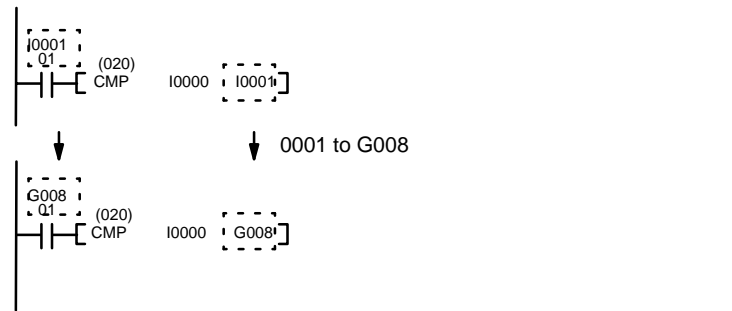

Changing I/O Names and Comments

I/O names and comments are handled the same as for when changing bit addresses, except that both bit and word addresses are affected. Refer to the previous section for details.

Procedure

- 1, 2, 3... 1. Select "N:Change data word" from the menu.



2. Select "W:Wd adr(with bit adr)" from the sub-menu.

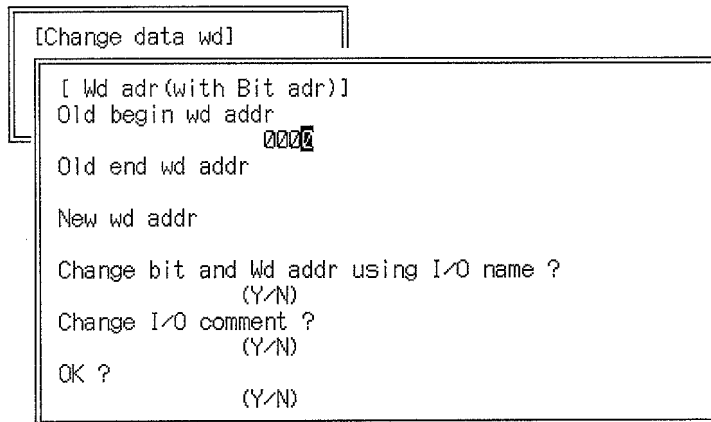

3. Enter the first address to be changed and press the Enter Key.
4. To change only one word, press the Enter Key.
- or To make multiple changes, enter the last address to be changed.
The start and end word address must be in the same data area, and the end address must be greater than the start address.
5. Enter the new word address.
When changing multiple words, enter the new address for the first address.
6. Set whether or not bit addresses with I/O names are to be changed.
7. Set whether the I/O comments are to be changed.
8. Select Y at "OK?" and then to execute the change press the Enter Key in response to the confirmation message.

A message will flash to indicate that the changes are being made and the program name will be displayed. The message and program name will be cleared from the screen when the changes are complete.

3-9 Editing Interrupt Programs

The following operations can be used to edit interrupt programs such as those for I/O interrupts and scheduled interrupts. Interrupt programs can be used only when the program type is set to Ladder. Interrupt programs are written and edited just like any other ladder diagram. Refer to previous parts of this section for details.

Procedure

- 1, 2, 3... 1. Press the End Key or Ctrl+M Keys to access the main programming menu.
2. Select "I>Edit intr program" from the menu.

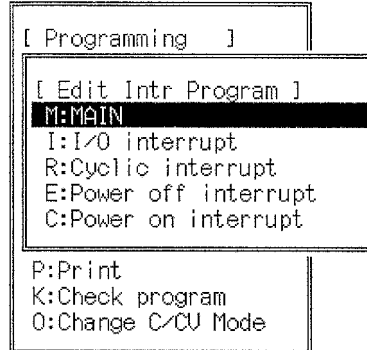

3. Select the type of program to edit.
If a I/O interrupt or cyclic (scheduled) interrupt program is selected, a screen will prompt for input of the I/O or scheduled interrupt number.

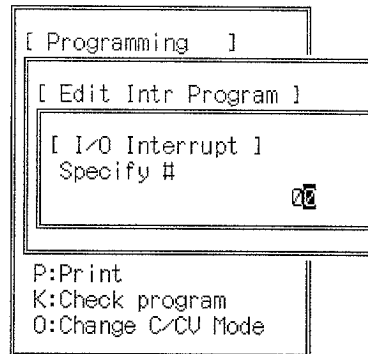

4. Enter the I/O number in the range: 0 to 31.

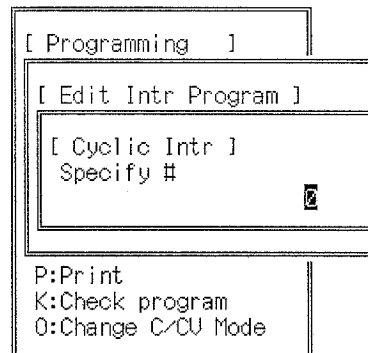

- or Enter the scheduled interrupt in the range: 0, 1.
5. Create or edit the ladder program for the selected interrupt.

3-10 Programming in the Mnemonic Display Mode

Ladder programs can be created in the mnemonic programming mode. Ladder programs created with ladder instructions in the mnemonic display mode and ladder programs created in the ladder programming modes are identical on the work disk, allowing programs to be created and read in either display mode.

Programs created in the mnemonic display mode are automatically written to the work disk, so that it is not necessary to use the Store operations.

Use the Edit I/O comments operation to create I/O comments.

Switch to a ladder display mode to create any required block comments, as they cannot be created in the mnemonic display mode.

Preparations

Clearing Memory

Delete the contents of the memory before creating a new program. Existing programs will be overwritten if not deleted before a new program is written.

Mnemonic Programming Screen

The editing mode and display mode will be indicated at the top-right of the screen.

Press the F1 to F10 Keys to select items from the function key menu displayed at the bottom of the screen. Press the Shift Key to change the function key menu.

After the editing mode is changed with the function keys, the mode displayed in the top-right of the screen will also change. The default mode is the read mode. Up to 20 lines of mnemonic program can be displayed in the read/write area of the screen.

```

<      >      Read      Mnemonic
Addr  Instruction  I/O      I/O com      Name :Main

```

```

1write 2 ins 3 addr 4strng 5oprnd 6 LD 7 AND 8 OR 9 OUT 0FUNO

```

```

1write 2 ins 3 addr 4strng 5oprnd 6 LD 7 AND 8 OR 9 OUT 0FUNO

```

Switch editing modes

Moving the Cursor

Press the Up and Down Keys to move the cursor up and down the display.
Press the PgUp and PgDn Keys to display the previous and next page.

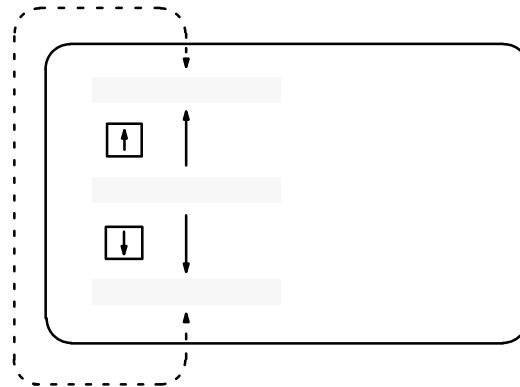
**Main Programming Menu**

Press the End Key or Ctrl+M Keys to access the main programming menu, which is shown below

```
[ Programming ]
S:Save program
L:Retrieve program
H:Change display
N:Change data wd
I>Edit intrrupt prog
C:Clear memory
P:Print
K:Check program
```

The “I>Edit intr program” is not displayed when the program type is set to SFC+ladder.

3-10-1 Entering Programs

- 1, 2, 3...**
1. Select “H:Change display” from the main menu.
 2. Select the mnemonic display mode from the menu.
The mnemonic display mode will be indicated along with the display mode at the top-right of the screen.
 3. Press the F1 Key to select the write editing mode. The write mode will be indicated at the top-right of the screen.

Entering Mnemonics with the Function Keys

- 1, 2, 3...**
1. Move the cursor to the address where the mnemonic is to be entered.
 2. Input the instruction using the function key (see following table), then press the Enter Key. The instruction will be displayed at the cursor position and the cursor will move to the next address.
 3. When an entire page of instructions has been input, press the PgDn Key to display the next addresses and allow more instructions to be input.
 4. Always use the check program operation as no program errors will occur if the mnemonic program is incorrect. The program is stored as it is input.

Entering Instructions

I/O names can be input instead of bit addresses, word addresses, or timer/counter numbers, provided the I/O names have been allocated using the Edit I/O name operations (see 4-1 *Editing I/O Names*).

While the prompt FUN(???) is displayed (F10), press the Enter Key or the Ctrl+F Keys to display a table of instructions.

Refer to CV500/CV1000 Operation Manual: Ladder Diagrams for information on the operands for each instruction.

Instruction	Key sequence	Comments
LD	F6 Bit_address CR	—
AND	F7 Bit_address CR	
OR	F8 Bit_address CR	
LD NOT	F6 Shift+F7 Bit_address CR	
AND NOT	F7 Shift+F7 Bit_address CR	
OR NOT	F8 Shift+F7 Bit_address CR	
AND LD	F7 F6 CR	
OR LD	F8 F6 CR	
ILD	F6 Shift+F10 Bit_address CR	—
!AND	F7 Shift+F10 Bit_address CR	
!OR	F8 Shift+F10 Bit_address CR	
ILD NOT	F6 Shift+F7 Shift+F10 Bit_address CR	
!AND NOT	F7 Shift+F7 Shift+F10 Bit_address CR	
!OR NOT	F8 Shift+F7 Shift+F10 Bit_address CR	
LDj	F6 Shift+F3 Bit_address CR	—
ANDj	F7 Shift+F3 Bit_address CR	
ORj	F8 Shift+F3 Bit_address CR	
LDi	F6 Shift+F4 Bit_address CR	
ANDi	F7 Shift+F4 Bit_address CR	
ORi	F8 Shift+F4 Bit_address CR	
ILDj	F6 Shift+F10 Shift+F3 Bit_address CR	—
!ANDj	F7 Shift+F10 Shift+F3 Bit_address CR	
!ORj	F8 Shift+F10 Shift+F3 Bit_address CR	
ILDi	F6 Shift+F10 Shift+F4 Bit_address CR	—
!ANDi	F7 Shift+F10 Shift+F4 Bit_address CR	
!ORi	F8 Shift+F10 Shift+F4 Bit_address CR	
OUT	F9 Bit_address CR	—
OUT NOT	F9 Shift+F7 Bit_address CR	
!OUT	F9 Shift+F10 Bit_address CR	
!OUT NOT	F9 Shift+F7 Shift+F10 Bit_address CR	
TIMER (TIM)	Shift+F5 Timer_number CR # SV CR	To set a word address for the SV, enter the word address instead of # SV.
COUNTER (CNT)	Shift+F6 Counter_number CR # SV CR	
Normal variation of instructions with function codes	F10 Function_code (Operand) CR	Input leading zeros for the function code.
Differentiate up variation of instructions with function codes	F10 Function_code Shift+F3 (Operand) CR	After entering the advanced instruction, enter operands and press the Enter Key if required.

Instruction	Key sequence	Comments
Differentiate down variation of instructions with function codes	F10 <i>Function_code</i> Shift+F4 (<i>Operand</i>) CR	
Immediate refresh variation of instructions with function codes	F10 <i>Function_code</i> Shift+F10 (<i>Operand</i>) CR	

Bit/Word Addresses and Data If an incorrect number is entered, press the Home Key and re-enter the value. It is not necessary to input leading zeros for addresses or SVs.
 I and Q are displayed only after an I/O table is registered.
 Refer to the *CV500/CV1000 Operation Manual: Ladder Diagrams* for information on using data registers and index registers (DR and IR).

Item	Bit address	Word address	Display on ladder diagram
Auxiliary Area	A <i>Bit_address</i>	A <i>Word_address</i>	A
CIO Area	<i>Bit_address</i>	<i>Word_address</i>	I: Input Q: Output
Constant	—	# <i>Value</i>	#
Counter Area	C <i>Counter_number</i>	C <i>Counter_number</i>	C
CPU Bus Link Area	G <i>Bit_address</i>	G <i>Word_address</i>	G
Data register	—	D <i>R Number</i>	DR
DM Area	—	D <i>DM_address</i>	D
EM Area	—	E <i>EM_address</i>	E
Index register	—	I <i>R Number</i>	IR
Indirect DM address	—	* D <i>DM_address</i>	*D
Indirect EM address	—	* E <i>EM_address</i>	*E
Step Area	S T <i>Step_number</i>	—	ST
Timer Area	T <i>Timer_number</i>	T <i>Timer_number</i>	T
Transition Area	T N <i>Transition_number</i>	—	TN

Editing Numbers

Use the following keys to edit previously input numbers.

Key	Function
Cursor	Move the cursor left and right along the input area.
Backspace	Deletes the character to the left of the cursor.
Del	Deletes the character at the cursor position.
Ins	Inserts a space at the cursor position.

Inputting with the Alphanumeric Keys

- 1, 2, 3... 1. Move the cursor to the address where the address or data is to be entered.
2. Enter the instruction with the alphanumeric keys, then press the Enter Key. The input instruction will be displayed at the cursor position and the cursor will move to the next address.
3. When an entire page of instructions has been input, press the PgDn Key to display the next addresses and allow more instructions to be input.

Inputting Instructions

Input instructions with the alphabet keys (A to Z) and numerical keys (0 to 9). Input instructions in a single line, including all operands. When inputting an instruction, press the Space Key to separate the mnemonic from operands and operands from operands.

It is not necessary to input leading zeros for bit or word addresses. Input address 00000 may be input as 0.

Press the Space Key to separate the prefix from the bit address.

Area	Key(s)
Auxiliary Area	A
CIO Area	None
CPU Bus Link Area	G
Constants	#
Counter Area	C
Data registers	DR
DM Area	D
EM Area	E
Index registers	IR
Indirectly addressed DM Area	*D
Indirectly addressed EM Area	*E
Step Area	ST
Timer Area	T
Transition Area	TN

To input the differentiate up variation of an instruction, enter the instruction and then press the Shift+F3 Keys.

To input the differentiate down variation of an instruction, enter the instruction and then press the Shift+F4 Keys.

To input the immediate refresh variation of an instruction, enter the instruction and then press the Shift+F10 Keys.

To input the differentiate up/down and immediate variation of an instruction, enter the instruction and then press Shift+F3 Keys or Shift+F4 Keys followed by the Shift+F10 Keys

Examples of Entering Instructions

Input	Operation
L D _ 2 0 1 CR	LD 000201
O R _ N O T _ T 2 4 CR	OR NOT T0024
T I M _ 1 _ # 1 0 0 CR	TIM 0001 #0100
M O V _ A 1 _ 5 CR	MOV(030) A001 0005
M O V Shift+F3 _ 1 0 _ 6 CR	jMOV(030) 0010 0006
S E T Shift+F4 Shift+F10 _ 1 CR	!iSET(016) 000001

Correcting Input

Use the following keys to edit previously input characters.

Key	Function
Cursor	Move the cursor left and right along the input area.
Backspace	Deletes the character to the left of the cursor.
Del	Deletes the character at the cursor position.
Ins	Inserts a space at the cursor position.
Shift+Home	Deletes all displayed instructions.

Note Always use the check program operation; no program errors will be detected if the mnemonic program is incorrect.

Editing Programs

Move the cursor to the instruction column to insert or delete an instruction. Instructions cannot be inserted or deleted when the cursor is at an operand.

It is not necessary to store a program after it is edited in the mnemonic display mode. The edited program will be automatically stored on the work disk. Always use the check program operation to avoid storing incorrect programs.

Changing an Instruction

- 1, 2, 3...**
1. Press the F1 or F2 Key in the Read or Insert mode to select the Write mode.
 2. Move the cursor to the instruction to be changed, enter the new instruction and press the Enter Key.

Inserting an Instruction

- 1, 2, 3...**
1. Press the F2 Key in the Read or Write mode to select the Insert mode.
 2. Move the cursor to the position where the instruction is to be inserted, enter the instruction and press the Enter Key.

The instruction will be inserted at the cursor position and subsequent lines of the original program will move down. The cursor will move to the position of the original instruction.

If function codes or any other input method that requires pressing the Enter Key is used while inserting an instruction, you will leave the Insert mode and will have to enter the Write mode to complete the instruction.

Instructions can be inserted down to the last line of the display. At the bottom of the display, press the PgDn Key to display the next page before inserting further instructions.

Deleting an Instruction

- 1, 2, 3... 1. Press the F1 or F2 Key in the Read or Insert mode to select the Write mode.
 2. Move the cursor to the instruction to be deleted and press the SPACE Key. The instruction at the cursor position will be deleted.
 or Press the BACKSPACE Key to delete the instruction above the cursor position.

Reading Programs

The following operations can be used to read a program from the work disk and display it in mnemonic form.

First press the F1 Key in the Write or Insert mode to select the Read mode and then proceed as shown in the following table to display 20 lines of the program from the designated instruction.

Method	Key sequence	Description
Reading a specified program address	F3 Address CR	It is not necessary to input leading zeros. Input address 000000 as 0.
Finding basic instructions	Press any key from F6 to F9 Operand CR or Shift+F5 (or F6, F8) Operand CR	Specify operands on the screen with the Up, Down, PgDn, and PgUp Keys or input them numerically. Leading zeros are not required on bit addresses.
Finding instructions from a specified function code.	Instruction executed every cycle: F10 Function_code CR Differentiate up/down instruction or immediate refresh instruction: F10 Function_code Shift+F3 (or F4, F10) CR	Input leading zeros of the function code. While the FUN(???) prompt is displayed, press the Enter Key or the Ctrl+F Keys to display a table of instructions. Select the required instruction with the cursor and press the Enter Key. The selected instruction will be displayed at the bottom of the screen. Press the Enter Key to start the search.
Finding instructions with specific operands	F4 Mnemonic _ Operand CR	Enter the instruction and operands with the alphanumeric keys. Press the Space Key to separate instructions from operands and operands from operands. Input leading zeros of the function code. Use the ? Key as a wildcard character to omit operands.
Finding operands	F5 Operand CR	Specify operands as a bit addresses, word addresses, or I/O names. Input leading zeros of the bit address. Only one operand can be specified.
Finding an I/O name	F5 I/O name CR	Finds the I/O name starting with the specified string.
Finding an I/O comment	Shift+F1 I/O comment CR	Finds the I/O comment starting with the specified string. The I/O comment will not be displayed.

Procedure

After specifying the read or find operation as described in the previous table, follow the procedure below.

- Press the Enter Key to start searching from program address 00000. During the operation, a message will flash at the top-right of the screen.
- When the specified input, instruction, or operand is found, 20 lines of the mnemonic program will be displayed beginning with the instruction that was found.
- Press the Enter Key to repeat the search.
- Press the Esc Key followed by the Tab Key to display the previously found instruction.
- Press the PgDn or PgUp Keys to display the page before or after the currently displayed page.
- Press the Esc Key to cancel the operation.

Scrolling

Press the PgDn or PgUp Keys to display the page after or before the current page.

Key	Description
PgDn	Read the next page.
PgUp	Read the previous page.

3-11 Checking the Program

The following operations are used to check to see if the ladder program on the work disk is correct. These operations can be used regardless of whether the program was written in ladder or mnemonic form.

Always use the check operation to check a newly created or edited ladder program after storing the program on the work disk.

- 1, 2, 3...**
1. Select "K:Check program" from the main programming menu and then specify the programs to be checked on the following display.
 A: All actions and transitions
 Check all ladder and mnemonic programs on the work disk.
 B: Current actions and transitions
 Check only the ladder or mnemonic program displayed on the screen.
- or If the program type is set to Ladder, the following display will not appear and the menu to set the check levels will appear.

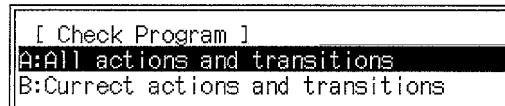

2. Select the check level.
 When the check level is selected, the program check will start and a message will flash on the display.

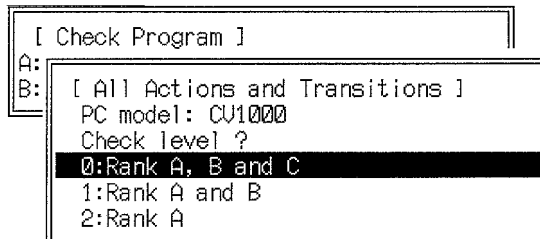

Error level	Description
A	Error that prevent execution or result in NOPs
B	Warnings, i.e, non-fatal errors
C	Parts left out of the program or output timing errors

The errors will be displayed when the program check is complete. If the errors cannot be displayed on a single page, use the PgDn and PgUp Keys to switch between the pages. If no errors were found, a message will be displayed to inform you. If error messages are displayed, correct the program and run the program check again. Press the Esc Key or Shift+Esc Keys to return to the main menu.

The time required for the program check depends on the size of the program. It may take over 2 minutes.

< > Check Level 0 Check prog

* * * Check program * * * Main

addr	Inst	Error
000007	OUT 1000200	Dup output err

Error Messages

Rank	Message	Description	Remedy
A	????	Program contents destroyed. Invalid instruction code.	Enter correct instructions at the ????
	Block err	Syntax error in instruction block. Number of LD instructions disagrees with number of logic block instructions (OR LD, AND LD).	Check the program.
	Dup # error	SBN or JME number used twice.	Check and correct program
	JME missing	No JME corresponding to JMP.	
	Loc. error	Instruction used in incorrect memory area	Check use of instruction and correct program
	No END instr	No END instruction in the program	Enter an END instruction at the end of the program.
	Operand err	Incorrect operand set for an instruction.	Enter correct operand.
	SBN missing	No SBN corresponding to SBS.	Check and correct program
	Step error	STEP, SNXT used incorrectly.	
	Undef. Step #	Step number used incorrectly.	
B	IL-ILC error	IL, ILC not used in pairs.	Check and correct program
	SBN-RET error	RET instruction or SBN-RET used incorrectly.	
C	Dup output err	Same output bit specified for more than one instruction controlling its status.	Correct the bit addresses. This problem can cause racing.
	JMP missing	No JMP address corresponding to JME address.	Check and correct program
	SBS missing	No SNS address corresponding to SBN address.	
	SFC error	Incorrect SFC program.	

3-12 Saving and Retrieving Programs

3-12-1 Saving Programs

Once a program has been completed in the work disk, it can be saved to a data disk or the hard disk using the following operations.

When the program is saved, I/O names, I/O comments, and block comments are saved simultaneously. When a program is partially saved, only I/O names or I/O comments used in the saved portion of program are saved.

Make sure that the data disk has been initialized and is not write-protected. Programs cannot be saved if they exceed the free space available on the data disk or hard disk.

The save operation cannot be selected if there is no program in the work disk.

Only Save all is available in the mnemonic display mode.

Menu item	Function
Save all	Saves the entire program on the work disk to the data disk or hard disk.
Save part	Saves the specified range of the program to the data disk or hard disk.
Save part (action,trans)	Saves the action or transition program currently displayed on the screen to the data disk or hard disk.
Save part (block)	Save the specified address range of the program to the data disk or hard disk.

- 1, 2, 3...
1. Press the End Key or Ctrl+M Keys to access the main programming menu.
 2. Select "S:Save program" from the menu. The menu that will appear depends on the type of program that has been specified.

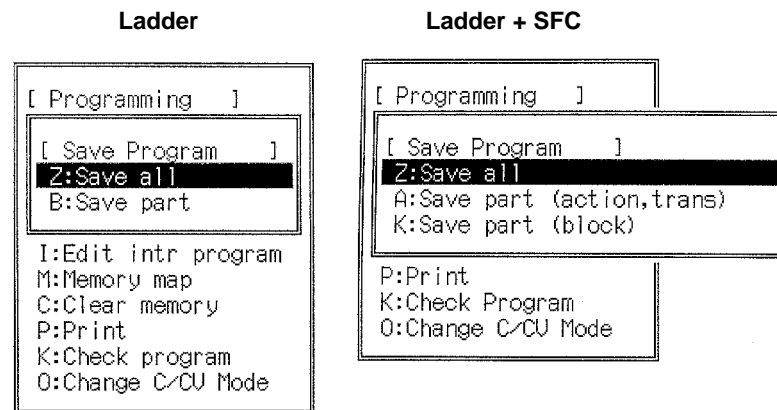

3. Select the desired save operation and proceed as described below.

Save All

A file name input area will be displayed when "Z:Save all" is selected.

- 1, 2, 3...
1. Enter the file name and press the Enter Key.
Enter the file name as up to 8 upper-case or lower-case characters. When specifying directories, a single directory name can have up to 8 characters with a total of 66 characters for the entire path name. Drive A is set default. To change the default setting, refer to 6-2-5 *Changing the Drive and Path Name*. See 6-2 *File Management* for more information about the directories. If the input file name already exists, a message will ask if the file should be overwritten.
 2. Press the Y and Enter Keys to overwrite the file. Press the Enter or N and Enter Keys to cancel and input a new file name.

- or If an existing file is to be overwritten, use the following procedure to input the file name:
 - a) Press the End Key or Ctrl+M Keys to display the file names.
 - b) Select the required file name with the cursor and press the Enter Key. The title input area will be displayed after the file name is input.
- 3. Enter the title as up to 30 characters and press the Enter Key. The title is optional, it is not necessary to enter one.
- 4. Press the Enter Key to save the program. The message Save All will flash on the screen. The programming screen will be displayed after the program has been saved.

Save Part

An address range input area will be displayed when "B:Save part" is selected.

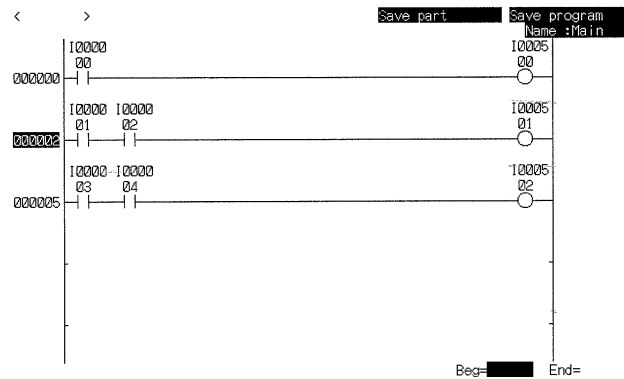

- 1, 2, 3... 1. Select the start address with the cursor and press the Enter Key, then select the end address and press the Enter Key. Press the PgDn and PgUp Keys to display the required instruction block, then press the Up and Down keys to move the cursor to the required address. The search operations can be used to find the instruction block or the address. After the range is set, the file name input area is displayed.
- 2. Enter the file name and press the Enter Key. Enter the file name as up to 8 upper-case or lower-case characters. When specifying directories, a single directory name can have up to 8 characters with a total of 66 characters for the entire path name. Drive A is set default. To change the default setting, refer to 6-2-5 Changing the Drive and Path Name. See 6-2 File Management for more information about the directories. If the input file name already exists, a message will ask if the file should be overwritten.
- 3. Press the Y and Enter Keys to overwrite the file. Press the Enter or N and Enter Keys to cancel and input a new file name.
- or If an existing file is to be overwritten, use the following procedure to input the file name:
 - a) Press the End Key or Ctrl+M Keys to display the file names.
 - b) Select the required file name with the cursor and press the Enter Key. The title input area will be displayed after the file name is input.
- 4. Enter the title as up to 30 characters and press the Enter Key. The title is optional, it is not necessary to enter one.
- 5. Press the Enter Key to save the program. The message Save Part will flash on the screen. The programming screen will be displayed after the program is saved. A file saved with the Save part operation can be retrieved only with the Retrieve

part operation. The time required to save part of the program depends on the size of the program. It may take over 2 minutes.

Save Part (Action,Trans) A file name input area will be displayed when "A:Save part (action,trans)" is selected. The procedure is the same as that for "Z:Save all" for ladder programs.

Save Part (Block) An address range input area will be displayed when the "K:Save part (block)" is selected. The procedure is the same as that for "B:Save part" for ladder programs.

3-12-2 Retrieving Programs

A program on a data disk or the hard disk can be retrieved to the work disk using the following operations. When the program is retrieved, I/O names, I/O comments, and block comments are retrieved simultaneously.

Procedure

- 1, 2, 3... 1. Press the End Key or Ctrl+M Keys to access the main programming menu.
2. Select "L:Retrieve program" from the menu.



3. Select "Z:Retrieve all" or "T:Retrieve part" from the menu, as required. Only the Retrieve all operation is available in the mnemonic display mode.

Menu item	Function
Retrieve all	Retrieve the program with the specified file name in the data disk or hard disk to the work disk. The program on the work disk is lost when a new program is retrieved.
Retrieve part	Retrieve the program with the specified file name in the data disk or hard disk to the work disk, from the specified address of the program already on the work disk. The "Retrieve part" can retrieve only files saved with the Save part operation.

Retrieve All A file name input area will be displayed when "Z:Retrieve all" is selected.

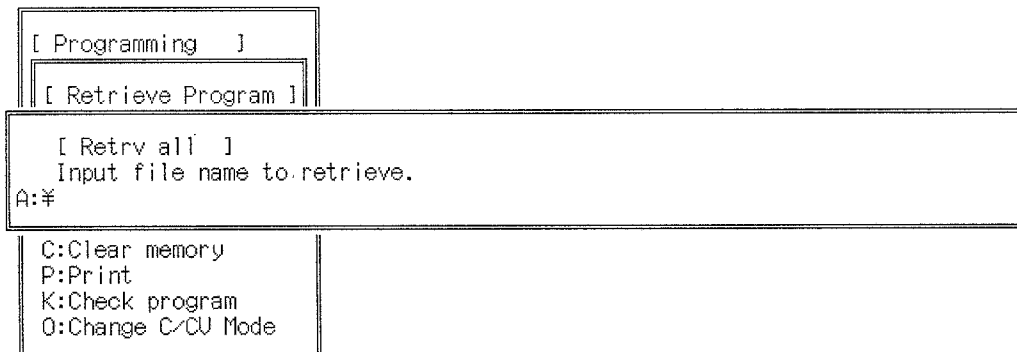

- 1, 2, 3...
 1. Enter the file name and press the Enter Key.
 2. Enter the file name as up to 8 upper-case or lower-case characters. Drive A is set default. To change the default setting, refer to 6-2-5 *Changing the Drive and Path Name*.
- or Press the End Key or Ctrl+M Keys to display the file name table, select the required file name with the cursor, and press the Enter Key to input the file name.
- 3. Press the Enter Key to retrieve the program.

The message Retrieve All will flash on the screen. The programming screen will be displayed after the program has been retrieved.

Retrieve Part

The Retrieve part operation can retrieve only files saved with the Save part operation. The destination address input area will be displayed when "T:Retrieve part" is selected.



Specify destination

- 1, 2, 3...
 1. Set the destination address and press the Enter Key. Press the PgDn and PgUp Keys to display the required instruction block, then press the Up and Down keys to move the cursor to the required address, and press the Enter Key.

The search operations can be used to find the instruction block or the address.

To specify the destination address at the end of the program, display the last instruction block, press the PgDn Key so that a message at the top-left of the screen indicates that the final page is displayed, then press the Enter Key. After the destination address is set, the file name input area is displayed.
 2. Enter the file name and press the Enter Key. Drive A is set default. To change the default setting, refer to 6-2-5 *Changing the Drive and Path Name*.
- or Press the End Key or Ctrl+M Keys to display the file name table, select the required file name with the cursor, and press the Enter Key to input the file name.
- 3. Press the Enter Key to retrieve the program.

The message Retrieve Part will flash on the screen. The programming screen will be displayed after the program has been retrieved.

3-13 Printing

The following operations can be used to print ladder diagrams and mnemonic lists. Before printing programs, connect and turn on the printer to enable printing.

- 1, 2, 3...
 1. Press the End Key or Ctrl+M Keys to access the main programming menu.
 2. Select "P:Print" from the menu.

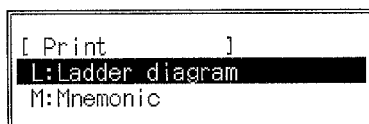

Ladder Diagrams

- 1, 2, 3... 1. Select "R:Ladder diagram" from the menu.
The print setting screen will be displayed.

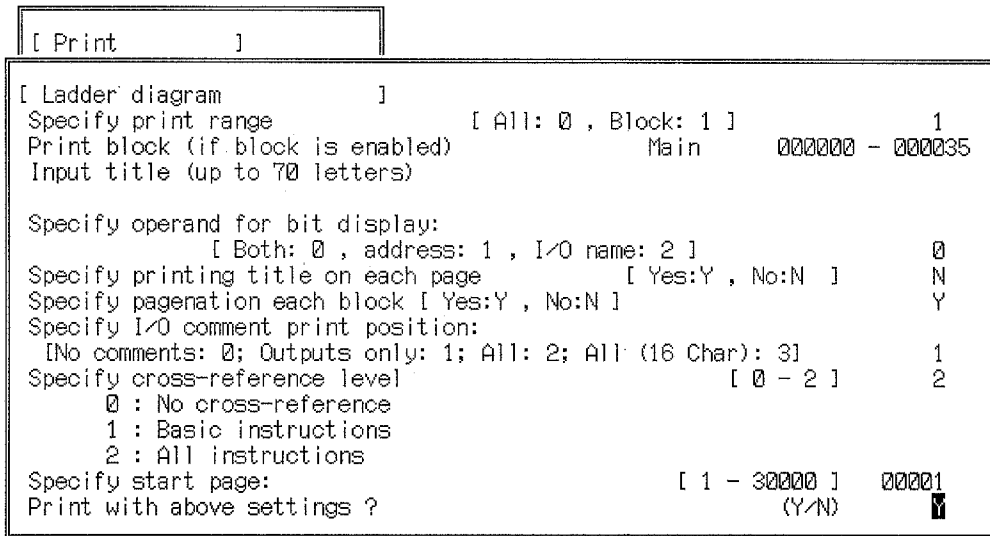

The default settings are shown in the above diagram. After the first printing operation, the settings from the previous print operation will be displayed as the defaults. Limit titles to 70 characters or less.

2. Move the cursor to the last line and press the Y and Enter Keys to start printing.
A message will flash during the printing operation. The main menu will be displayed when printing is complete.
3. Press the Esc Key to cancel printing and return to the main menu.
All characters in the print buffer will be printed before printing stops. If cross-references are printed, the search for the cross-references delays the start of printing by more than 10 minutes.

Print Settings

The print settings are described in the following table.

Item	Input	Description
Print range	0	The main program and all interrupt programs are printed out if the program type is set to Ladder. All action and transition programs are printed out if the program type is set to SFC+Ladder.
	1	Set the block to be printed if the program type is set to Ladder. Set the action and transition numbers or the I/O names to be printed if the program type is set to SFC+Ladder. Also set the first and last addresses for the printing range. Input A (ALL) for the first address to print all parts of the designated block. Input E (END) for the last address to print the portion until the END command is found.
Input title	Character input	Enter the title in the title column. This title will appear on the printout.
Operand for bit display	0	Print both I/O addresses and I/O names.
	1	Print I/O addresses only.
	2	Print I/O names only.
Printing title on each page	Y	Do not print over the perforations in the computer paper.
	N	Continuous printing, ignoring the perforations in the computer paper.
Pagination each block (ladder only)	Y	A new page for each block.
	N	Continuous printing of blocks.
Pagination each action/transition program (SFC + ladder)	Y	A new page for each action or transition program.
	N	Continuous printing of action and transition programs.
I/O comment	0	Do not print I/O comments.
	1	Print I/O comments for outputs only.
	2	Print I/O comments for all instructions.
Cross-reference level	0	Do not print cross-references.
	1	Print cross-references only for instructions controlling bit status.
	2	Print cross-references for all instructions.
Start page	Numeric input	Enter the page number of the first page to be printed.
Print with above settings ?	Y	Start printing.
	N	Correct the settings.

Mnemonics

- 1, 2, 3... 1. Select "N:Mnemonic" from the print menu.
The print setting screen will be displayed.

```

[ Print      ]
[ Mnemonic List      ]
Specify print range      [ All: 0 , Block: 1 ]      0
Print block (if block is enabled)
Input title (up to 70 letters)

Specify operand for bit display:
[ Both: 0 , address: 1 , I/O name: 2 ]      0
Specify printing title on each page      [ Yes:Y , No:N ]      N
Specify I/O comment print position:
[ No comment : 0 , OUT only : 1 , All : 2 ]      0
Specify start page:      [ 1 - 30000 ]      00001
Print with above settings ?      (Y/N)      Y
    
```

The default settings are shown in the above diagram. After the first printing operation, the settings from the previous print operation will be displayed as the defaults. Limit titles to 70 characters or less.

The print settings are identical to the settings for printing ladder diagrams.

2. Move the cursor to the last line and press the Y and Enter Keys to start printing.

A message will flash during the printing operation. The main menu will be displayed when printing is complete.

3. Press the Esc Key to cancel printing and return to the main menu.

However, all characters in the print buffer will be printed before printing stops.

Sample Print-out of a Ladder Diagram

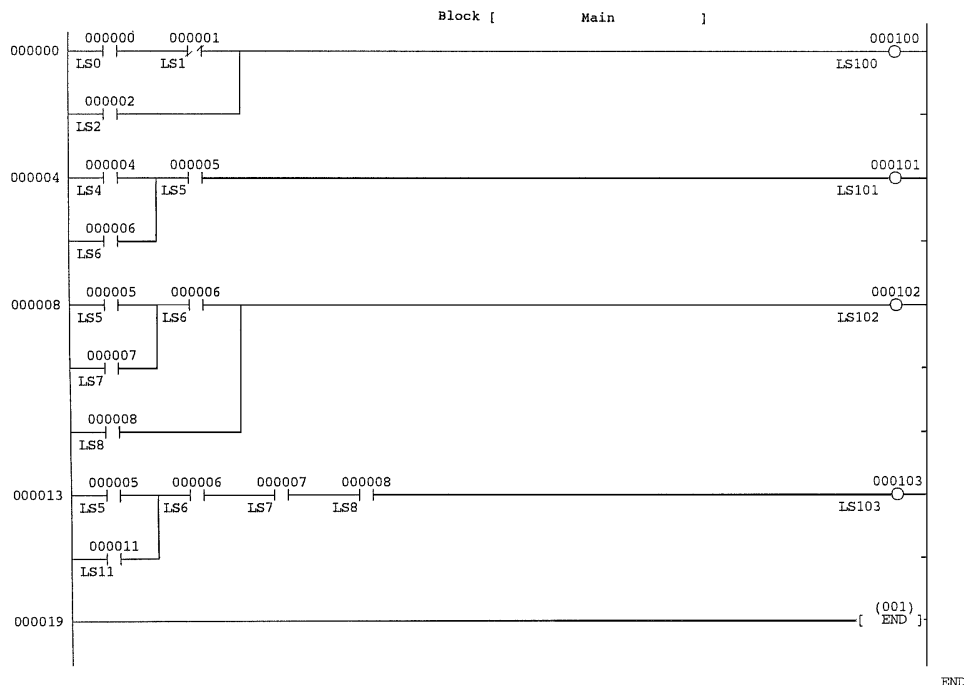

Sample Print-out of a Mnemonic List

```

< < <
TEST PRG
> > > 27/12/91, PAGE = 0001

Block [ Main ]
addr Inst I/Oaddr I/Oname I/Ocom
000000 LD 000001 LBL001
000001 AND 000002 LBL002
000002 AND 000003 LBL003
000003 AND 000004 LBL004
000004 AND 000005
000005 AND 000006
000006 AND 000007
000007 AND 000008
000008 AND 000009
000009 OUT 001000 LQ010
000010 LD 000201 LBL11
000011 AND 000202 LBL12
000012 AND 000203 LBL13
000013 AND 000204 LBL14
000014 AND 000205 LBL15
000015 AND 000206 LBL16
000016 AND 000207 LBL17
000017 AND 000208 LBL18
000018 AND 000209 LBL19
000019 OUT 002000 LQ020
000020 LD 000301 LBL21
000021 AND 000302 LBL22
000022 AND 000303 LBL23
000023 AND 000304 LBL24
000024 AND 000305 LBL25
000025 AND 000306 LBL26
000026 AND 000307 LBL27
000027 AND 000308 LBL28
000028 AND 000309 LBL29
000029 OUT 003000 LQ030
000030 LD 000401 LBL31
000031 AND 000402 LBL32
000032 AND 000403 LBL33
000033 AND 000404 LBL34
000034 AND 000405 LBL35
000035 AND 000406 LBL36

```

SECTION 4

Editing

This section provides the procedures required to edit programming. Editing is performed using menus and examples of their use are provided. Read the CV-series PC Operation Manuals and Installation Guide before editing.

4-1	Editing I/O Names	131
4-1-1	Basic Procedure	133
4-1-2	Saving I/O Names	133
4-1-3	Retrieving I/O Names	134
4-1-4	Clearing I/O Names	134
4-1-5	Printing I/O Names	135
4-1-6	Linking I/O Names to Programs	136
4-1-7	Deleting Unused I/O Names	136
4-1-8	Checking I/O Names and I/O Addresses	136
4-1-9	Sorting I/O Names	137
4-1-10	Finding I/O Names	137
4-2	Editing I/O Comments	138
4-2-1	Specifying I/O Addresses	140
4-2-2	Saving I/O Comments	140
4-2-3	Retrieving I/O Comments	140
4-2-4	Clearing I/O Comments	141
4-2-5	Printing I/O Comments	141
4-2-6	Finding I/O Comments	142
4-3	Linking Programs	142
4-3-1	Creating Link Parameters	144
4-3-2	Link Program Menu	146
4-3-3	Setting the Link Mode	147
4-3-4	Executing the Link	147
4-3-5	Saving Link Parameters	150
4-3-6	Retrieving Link Parameters	150
4-3-7	Clearing Link Parameters	150
4-3-8	Printing Link Parameters	150
4-4	Editing the Data Memory Area	151
4-4-1	Reading a DM Address	153
4-4-2	Copying	153
4-4-3	FILL	153
4-4-4	Printing	154
4-4-5	HEX-ASCII	154
4-4-6	Switching Memory Banks	155
4-4-7	Saving DM Data	155
4-4-8	Retrieving DM Data	156
4-4-9	Saving File Data	156
4-4-10	Retrieving File Data	157
4-5	Editing the I/O Table	157
4-5-1	Writing I/O Tables	158
4-5-2	Checking I/O Tables	167
4-5-3	Saving I/O Tables	168
4-5-4	Retrieving I/O Tables	169
4-5-5	Clearing I/O Tables	169
4-5-6	Customizing I/O Tables	169
4-5-7	PC Setup	169

4-6	Editing Network Support Tables	169
4-6-1	SYSMAC NET Data Link Tables	170
4-6-2	SYSMAC LINK Data Link Tables	173
4-6-3	Routing Tables	180
4-7	Editing PC IDs	186
4-7-1	Writing PC IDs	188
4-7-2	Changing PC IDs	188
4-7-3	Edit PC ID Menu	189
4-7-4	Saving PC IDs	189
4-7-5	Retrieving PC IDs	189
4-7-6	FILL	190
4-7-7	Clearing PC IDs	190
4-7-8	Printing PC IDs	190
4-7-9	Checking PC IDs	191
4-7-10	Sorting PC IDs	191
4-7-11	Finding PC IDs	192

4-1 Editing I/O Names

The following operations can be used display the I/O name table and write, correct, edit, find, link, or print I/O names.

I/O names that are written, corrected, or edited with these operations are automatically stored to the work disk; it is not necessary to use the store operation to save them. I/O names edited with these operations are set for the SFC or Ladder displays and can be automatically displayed on the screen after the program is linked. Refer to the *CV Support Software Version 2: Basics* for information on how to use I/O names.

Note Do not turn off the power supply or press the reset button while the I/O names are being edited. This may destroy the I/O name area.

- 1, 2, 3... 1. Select "S:Edit I/O names" from the main offline menu.

The initial display will appear in the edit mode and "EDIT" will be displayed at the top-right of the screen. Sixteen I/O names are displayed on each page of the screen.

Use the PgUp and PgDn Keys to display the previous and next page, and use the Up and Down Keys to move the cursor up and down the rows.

The insertion mark will flash in the I/O address input area at the bottom of the screen. I/O address corresponding to the line selected by the cursor can be written or edited. The I/O address is designated to write or edit the I/O name for it.

#	address	I/Oname	I / O comment
00001			
00002			
00003			
00004			
00005			
00006			
00007			
00008			
00009			
00010			
00011			
00012			
00013			
00014			
00015			
00016			

2. Press the Esc Key or Shift+Esc Keys to return to the main offline menu.

Writing and Editing I/O Names

Key sequence	Operation
Move cursor (or <i>I/O_number</i>) CR <i>I/O_name</i> CR	<p>The I/O address input area corresponding to the line selected by the cursor will be displayed at the bottom of the screen. If an I/O address is already set for the line selected by the cursor, this I/O address will appear in the input area.</p> <ol style="list-style-type: none"> 1. Press the Enter Key after entering or changing the I/O address. The I/O address can be specified as either a bit address or word address. Refer to the next table and <i>3-5 Programming in Ladder Form</i> for details of inputting I/O addresses. The I/O name input area will appear after the I/O address has been input. 2. Enter or change the I/O name and press the Enter Key. I/O names are case-sensitive; upper-case and lower-case letters are treated as different. Characters other than from A to Z cannot be used as the 1st and 2nd characters. Numbers can be input from the 3rd character. Restrict I/O names to 8 characters or less. The data area prefixes TR, ST, AC, and TN and the customized prefixes set by the user may not be used in an I/O name. 3. Press the Enter Key to input the I/O name and I/O address into the table and move the cursor down the next line.

Key Sequences in the Edit Mode

Operation	Key sequence	Function
Copying	Move cursor F7 Move cursor F8 Move cursor F10	<p>Press to copy a specified range of I/O names to a specified destination line.</p> <ol style="list-style-type: none"> 1. Move the cursor to the start point of the range to be copied and press the F7 Key. 2. Move the cursor to the end point of the range to be copied and press the F8 Key. 3. Move the cursor to the copy destination and press the F10 Key.
Deleting	Move cursor F7 Move cursor F9	<p>Press to delete a specified range of I/O names.</p> <ol style="list-style-type: none"> 1. Move the cursor to the start point of the range to be deleted and press the F7 Key. 2. Move the cursor to the end point of the range to be deleted and press the F9 Key.
Inputting bit addresses	F3 <i>Bit_address</i>	Press to input a bit address.
Inputting word addresses	F2 <i>Word_address</i>	Press to input a word address.
Moving	Move cursor F7 Move cursor F9 Move cursor F10	<p>Press to move a specified range of I/O names behind a specified destination line.</p> <ol style="list-style-type: none"> 1. Move the cursor to the start point of the range to be moved and press the F7 Key. 2. Move the cursor to the end point of the range to be moved and press the F9 Key. 3. Move the cursor to the destination and press the F10 Key.
Moving to a specific line	F6 <i>Line_number</i> CR	Press to read data from a specified line number.
Moving to the beginning	F4	Press to display the first page of I/O names.
Moving to the end	F5	Press to display the last page of I/O names.

- Note**
1. Press the Up and Down Keys to move the cursor vertically.
 2. The F8 and F9 Keys are effective only after the F7 Key is pressed.

4-1-1 Basic Procedure

- 1, 2, 3... 1. Press the End Key or Ctrl+M Keys to display the main edit menu.

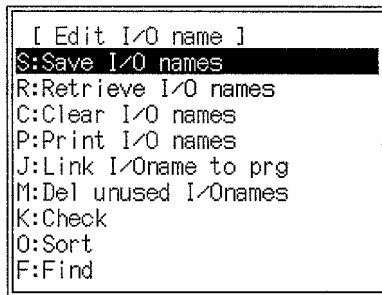

2. Select the required operation and then proceed as described in the following sections. The basic function of each operation is described in the following table.

Edit I/O Name Operations

Operation	Function
Check	Checks I/O name data and displays any error found.
Clear I/O names	Clears all I/O names from the work disk.
Find	Finds an I/O name or I/O address.
Del unused I/O names	Deletes I/O names not used in the user program.
Link I/O name to UM	Attaches I/O names created with the Edit I/O Name operations to a user program.
Print I/O names	Prints I/O names from the work disk.
Retrieve I/O names	Retrieves I/O names on the data disk or hard disk to the work disk.
Save I/O names	Saves the I/O names on the work disk to the data disk or hard disk.
Sort	Sorts the I/O names according to I/O addresses or I/O names.

4-1-2 Saving I/O Names

- 1, 2, 3... 1. Select "S:Save I/O names" from the main menu.

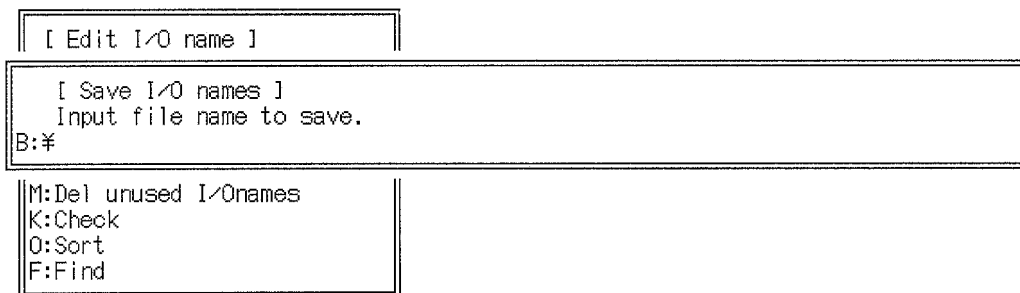

2. Input the file name and press the Enter Key.
 To enter an existing file name, press the End Key or Ctrl+M Keys to display the current file names, select the required file name with the cursor, and press the Enter Key.
3. If the input file name already exists, a message will ask if the file should be overwritten. Press the Y and Enter Keys to overwrite the file or press the Esc Key or N and Enter Keys to cancel and input a new file name.

When the Y and Enter Keys are pressed, the I/O name data will be saved on the data disk.

Note Enter the file name as up to 8 characters. Lower-case characters are converted to upper-case. A single directory name can have up to 8 characters with a total of 66 characters for the entire path name. See 6-2 File Management for more information about directories.

4-1-3 Retrieving I/O Names

- 1, 2, 3... 1. Select "R:Retrieve I/O names" from the main menu.

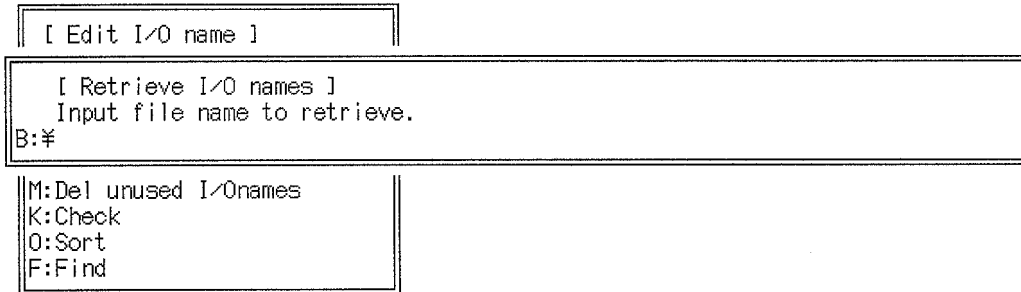

2. Input the file name and press the Enter Key.

To enter an existing file name, press the End Key or Ctrl+M Keys to display the current file names, select the required file name with the cursor, and press the Enter Key.

I/O names will be retrieved from the data disk. All I/O names in the user program will be replaced by the new I/O names from the disk. If the user program contains only I/O addresses, the new I/O names are appended to the existing I/O addresses.

The time required to retrieve I/O names depends on the size of the program. It may take over 8 minutes.

4-1-4 Clearing I/O Names

- 1, 2, 3... 1. Select "C:Clear I/O names" from the main menu.
A prompt message will be displayed.

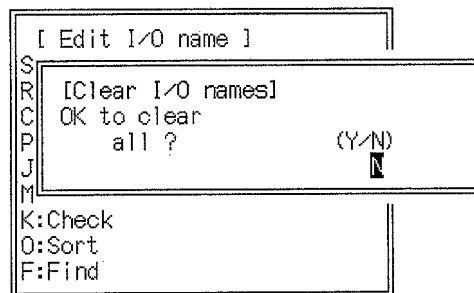

2. Press the Y and Enter Keys to clear the I/O names.
or Press the Esc Key or N and Enter Keys to cancel and return to the main menu.

4-1-5 Printing I/O Names

Up to one-hundred I/O names can be printed per page.

- 1, 2, 3... 1. Select "P:Print I/O names" from the main menu. The following display will appear.

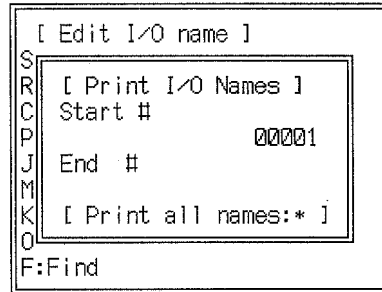

2. Set the start line number. Initially, the value 00001 will be displayed. Press the Enter Key to start printing from line 00001.

To print all I/O names from line 00001 to the last line, press the Backspace Key to clear the displayed number, and press the Shift, *, and Enter Keys. If this is done, it is not necessary to enter the number of the last line to be printed.

3. Enter the end line number and press the Enter Key.

Initially, the value 99999 will be displayed. Press the Enter Key to print all I/O names up to line 99999. To enter a different end line number, press the Backspace Key to delete each digit before entering the new number. Enter the leading zeros to give a 5-digit number.

4. Press the Enter Key to start printing.

A message will flash during the printing operation. The Print I/O Names menu will be displayed when printing is complete.

5. Press the Esc Key to cancel printing and return to the main menu.

All characters in the print buffer will be printed before printing stops.

Sample Print-out of I/O Name Data

I/O name list 27/12/91 PAGE = 001

#	address	I/Oname	I/O comments	#	address	I/Oname	I/O comments
00001	I000000	LS0	Load 3				
00002	I000001	LS1	load 2				
00003	I000002	LS2	water 1				
00004	I000003	LS3	water 2				
00005	I000004	LS4	gliding 1				
00006	I000005	LS5	gliding 2				
00007	I000006	LS6	gliding 3				
00008	I000007	LS7	gliding 4				
00009	I000008	LS8	gliding 5				
00010	I000009	LS9	dry 1				
00011	I000010	LS10	dry 2				
00012	I000011	LS11	unload				
00013	I000012	LS12	unload				
00014	I000013	LS13	start 1				
00015	I000014	LS14	start 2				
00016	I000015	LS15	start 3				
00017	I000100	LS100	over-run				
00018	I000101	LS101	over-run				
00019	I000102	LQ102	stop 1				
00020	I000103	LQ103	stop 2				
00021	I000104	LQ104	stop 3				
00022	I000105	LQ105	stop 4				
00023	I000106	LQ106	crane				
00024	I000107	LQ107	crane				
00025	I000108	GT1	drain				
00026	I000109	LS200	scrap 1				
00027	I000110	GT	scrap 2				
00028	I000111	LS198	scrap 3				
00029	I000112	LS199	scrap 4				
00030	I000113	LS113	scrap 5				
00031	I000114	LS114	scrap 6				
00032	I000115	LS115	scrap 7				

4-1-6 Linking I/O Names to Programs

- 1, 2, 3... 1. Select "J:Link I/O name to prg" from the main menu.
A prompt message will be displayed.

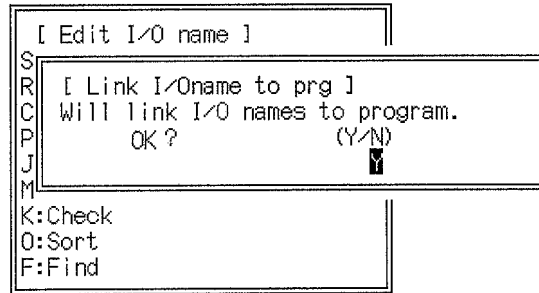

2. Press the Enter Key to link the I/O name.
- or Press the Esc Key or N and Enter Keys to cancel and return to the main menu.
The time to link the I/O name data depends on the size of the program. It may take over 8 minutes.

4-1-7 Deleting Unused I/O Names

- 1, 2, 3... 1. Select "M:Del unused I/O names" from the main menu.
A prompt message will be displayed.

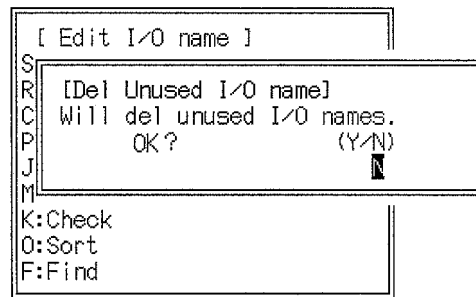

2. Press the Y and Enter Keys to delete unused I/O names.
- or Press the Esc Key or Enter Key to cancel and return to the main menu.

4-1-8 Checking I/O Names and I/O Addresses

- 1, 2, 3... 1. Select "K:Check" from the main menu. The following display will appear.

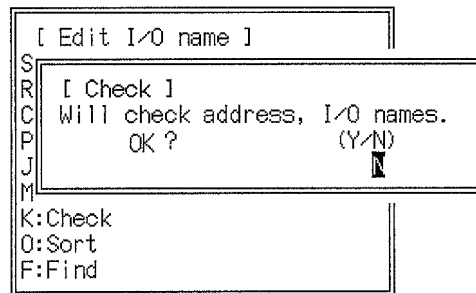

2. Press the Y and Enter Keys to run the check.
- or Press the Esc Key or Enter Key to cancel and return to the main menu.
The following three points will be checked:
 - Duplicate I/O addresses

- I/O address range
- Duplicate I/O names

An error message will be displayed if an error is discovered.

If *continue* is displayed at the bottom of the screen, press the PgDn Key to display the next page of error messages. "End" will be displayed at the end of the error messages.

3. Press the PgDn Key to return to the first page of the error message display. A message will indicate if no errors were detected.
 4. Press the Esc Key to return to the prompt message.
- or Press the Shift+Esc Keys to return to the Edit screen.

4-1-9 Sorting I/O Names

- 1, 2, 3... 1. Select "O:Sort" from the main menu.
The Sort menu will be displayed.

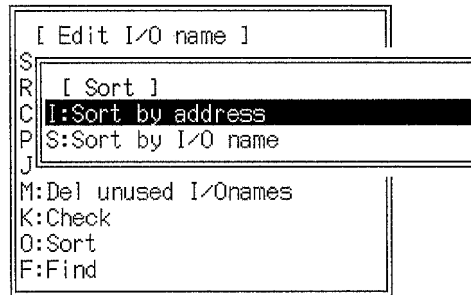

2. Press the I Key to sort in order of the I/O addresses.
- or Press the S Key to sort in order of the I/O names.
A prompt message will be displayed.
3. Press the Y and Enter Keys to sort the unused I/O names or press the Esc Key or Enter Key to cancel and return to the main menu.

I/O names will be sorted in the following order:

I/O addresses

CIO Area address first and then by prefixes in the following order: A, T, C, G, D, E, ST, AC, TN. Bits will be placed before words.

I/O names

Numbers (0-9), letters (a-z)

The Edit screen will be displayed when the sort is complete. The time to sort the I/O name data depends on the number of I/O names. It may take over 30 minutes.

4-1-10 Finding I/O Names

- 1, 2, 3... 1. Select "F:Find" from the main menu.
A message will be displayed asking whether to find an I/O name or I/O address.

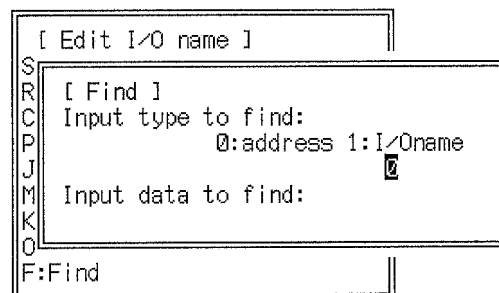

2. Press the 0 and Enter Keys to find an I/O address or the 1 and Enter Keys to find an I/O name.
 3. Enter the data to find and press the Enter Key.
 If matching data is found, the I/O names will be displayed. A message will be displayed at the top-left of the screen if no matching data is found.
- Repeat the steps above to repeat the search operation.

4-2 Editing I/O Comments

I/O comments are displayed in a table for each data area to allow them to be written, corrected, edited, printed or searched.

I/O comments written, corrected, and edited with these operations are automatically stored to the work disk; it is not necessary to use the store operation to store them. The I/O comments edited with these operations are displayed on the SFC, ladder, and mnemonic displays.

Select "C:Edit I/O comments" from the main offline menu. The following message will be displayed.

```

[ I/O Address ]
Input address           [      ]
    
```

Enter the key sequences below to input a word address or bit address:

F2 (Word) or F3 (Bit), Data area prefix, Address, Enter Key.

When the address is input, the I/O comment edit screen will be displayed. Up to sixteen bit addresses (equivalent to one word) and I/O comments can be displayed on each page of the screen.

address	I / O c o m m e n t	I/Oname
000000		
000001		
000002		
000003		
000004		
000005		
000006		
000007		
000008		
000009		
000010		
000011		
000012		
000013		
000014		
000015		

Use the PgDn and PgUp Keys to display the previous and next page. Use the Up and Down Keys to move the cursor up and down the rows.

The insertion mark will flash in the I/O comment input area at the bottom of the screen and the I/O comment corresponding to the bit address selected by the cursor. Press the Left and Right Keys to move the insertion point in the input area.

Press the Enter Key to input the I/O comment into the table and move the cursor down the next line. I/O comments can be up to 30 alphanumeric characters long. Press the Esc Key or Shift+Esc Keys to return to the main offline menu.

The following menu can be accessed by pressing the End Key. The operations on this menu are described in more detail in following sections.

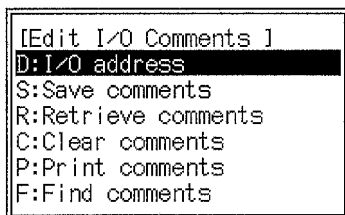

Operation	Function
Clear comments	Clears all I/O comments from the work disk.
Find comments	Finds and displays I/O comments.
I/O address	Press to specify the I/O address to display on the screen. Use this item to change the displayed data memory area.
Print comments	Prints I/O comments from the work disk.
Retrieve comments	Retrieves I/O comments on the data disk or hard disk to the work disk.
Save comments	Saves the I/O comments on the work disk to the data disk or hard disk.

Note Do not turn off the power supply or press the reset button while the I/O comments are being edited. This may destroy the I/O comment area.

Key Operations in the Edit Mode

Operation	Key sequence	Function
Inputting word addresses	F2	Press to input a word address.
Inputting bit addresses	F3	Press to input a bit address.
Moving to the beginning	F4	Press to display the first page of the data memory.
Moving to the end	F5	Press to display the last page of the data memory.
Copying	Move cursor F7 move cursor F8 move cursor F10	Press to copy a specified range of I/O names to a specified destination line. 1. Move the cursor to the start point of the range to be copied and press the F7 Key. 2. Move the cursor to the end point of the range to be copied and press the F8 Key. 3. Move the cursor to the copy destination and press the F10 Key.
Deleting	Move cursor F7 move cursor F9	Press to delete a specified range of I/O names. 1. Move the cursor to the start point of the range to be deleted and press the F7 Key. 2. Move the cursor to the end point of the range to be deleted and press the F9 Key.
Moving I/O names	Move cursor F7 move cursor F9 move cursor F10	Press to move a specified range of I/O names to a specified destination line. 1. Move the cursor to the start point of the range to be moved and press the F7 Key. 2. Move the cursor to the end point of the range to be moved and press the F9 Key. 3. Move the cursor to the destination and press the F10 Key.

Note 1. Press the Up and Down Keys to move the cursor vertically.

- The F8 and F9 Keys are effective only after the F7 Key is pressed.

4-2-1 Specifying I/O Addresses

- 1, 2, 3... 1. Select "D:I/O address" from the main menu.

```
[Edit I/O Comments ]
[ I/O Address ]
Input address          [      ]
F:Find comments
```

2. Enter the word address or bit address to be read:
F2 (Word) or F3 (Bit), Data area prefix, Address, Enter Key.
Enter the data area prefix in upper-case letters.

4-2-2 Saving I/O Comments

- 1, 2, 3... 1. Select "S:Save comments" from the main menu.

```
[Edit I/O Comments ]
[ Save Comment Data ]
Input file name to save.
A:\
F:Find comments
```

2. Input the file name and press the Enter Key.
To enter an existing file name, press the End Key or Ctrl+M Keys to display the current file names, select the required file name with the cursor, and press the Enter Key.
3. If the input file name already exists, a message will ask if the file should be overwritten. Press the Y and Enter Keys to overwrite the file or press the Esc Key or N and Enter Keys to cancel and input a new file name.
When the Y and Enter Keys are pressed, the I/O comment data will be saved on the data disk.

Note Enter the file name as up to 8 characters. Lower-case characters are converted to upper-case. A single directory name can have up to 8 characters with a total of 66 characters for the entire path name. See *6-2 File Management* for more information about directories.

4-2-3 Retrieving I/O Comments

The procedure to retrieve I/O comments is described below, using the data disk as an example.

- 1, 2, 3... 1. Select "R:Retrieve comments" from the main menu.

```
[Edit I/O Comments ]
[Retrieve Comment Data ]
Input file name to retrieve.
A:\
F:Find comments
```

2. Input the file name and press the Enter Key. I/O comments will be retrieved from the data disk.

To enter an existing file name, press the End Key or Ctrl+M Keys to display the current file names, select the required file name with the cursor, and press the Enter Key.

4-2-4 Clearing I/O Comments

- 1, 2, 3... 1. Select "C:Clear comments" from the main menu. A prompt message will be displayed.

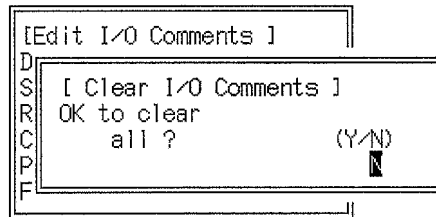

2. Press the Y and Enter Keys to clear the I/O comments.
- or Press the N and Enter Keys to cancel and return to the Edit I/O comments menu.

4-2-5 Printing I/O Comments

One-hundred I/O comments can be printed on each page. No blank lines are left for I/O addresses with no allocated I/O comments.

- 1, 2, 3... 1. Select "P:Print comments" from the main menu. The following display will appear.

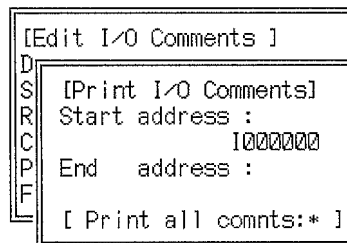

2. Enter the start line number and press the Enter Key to start printing.
Initially, the data area prefix and word address or I/O address will be displayed. If necessary, change the data area prefix and word address or I/O address.
3. Press the Enter Key to print with the displayed setting.
- or To print all I/O comments (all words or bits in all data memory areas), press the Shift, *, Enter Keys. It is not necessary to enter the number of the last I/O address.
4. Enter the end I/O address and press the Enter Key.
Initially, the largest value in the data area specified for the start I/O address will be displayed.
5. Press the Enter Key to start printing.
A message will flash during the printing operation. The Print Comments menu will be displayed when printing is complete.
6. Press the Esc Key to cancel printing and return to the main menu. All characters in the print buffer will be printed before printing stops.

Sample Print-out of I/O Comment Data

I/O Comment List

27/12/91 PAGE = 001

Address	I/O comment	I/Oname	Address	I/O comment	I/Oname
I000000	load 3	LS0			
I000001	load 2	LS1			
I000002	water 1	LS2			
I000003	water 2	LS3			
I000004	gilding 1	LS4			
I000005	gilding 2	LS5			
I000006	gilding 3	LS6			
I000007	gilding 4	LS7			
I000008	gilding 5	LS8			
I000009	dry 1	LS9			
I000010	dry 2	LS10			
I000011	unload	LS11			
I000012	unload	LS12			
I000013	start 1	LS13			
I000014	start 2	LS14			
I000015	start 3	LS15			
I000100	over-run	LS100			
I000101	over-run	LS101			
I000102	stop 1	LQ102			
I000103	stop 2	LQ103			
I000104	stop 3	LQ104			
I000105	stop 4	LQ105			
I000106	crane	LQ106			
I000107	crane	LQ107			
I000108	drain	GTT			
I000109	scrap 1	LS200			
I000110	scrap 2	GT			
I000111	scrap 3	LS198			
I000112	scrap 4	LS199			
I000113	scrap 5	LS113			
I000114	scrap 6	LS114			
I000115	scrap 7	LS115			

4-2-6 Finding I/O Comments

You can use the following operation to search I/O comments. It is not necessary to input the entire string; any portion may be used.

- 1, 2, 3... 1. Select "F:Find" from the main menu.

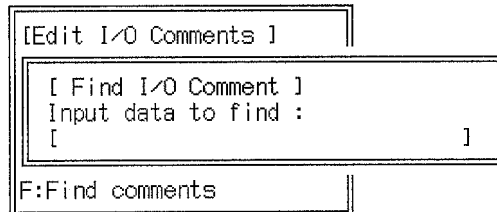

2. Enter the character string to search for in I/O comments and press the Enter Key.

If matching data is found, the word containing the I/O comment will be displayed. A message will be displayed at the top-left of the screen if no matching I/O comment is found.

Repeat the steps above to repeat the search operation.

4-3 Linking Programs

This operation links programs on the data disk in a predetermined order into a single program on the work disk. The order in which the files are linked is set from the link parameter table.

I/O names and I/O addresses that exist in more than one file are standardized to the I/O names and I/O addresses for the bit (or word) address in the file with the highest priority.

Files can be linked from more than one data disk.

Creating the Link Parameters Link parameters are set on the screen as described below.

- 1, 2, 3...** 1. Enter the files to be linked in the order of priority.

No.	File name
1	FILEC
2	AAA
3	FILE2
4	CCC
5	BBB
i	i

If the files contain I/O names or I/O comments, append the suffix SBL or CMT, respectively, to the file name. The suffices are not required for user programs.

2. Select "E:Exec link" from the Link Program menu to link the files according to the rules that follow.

SFC Programs

The program with #1 priority remains unchanged.

Programs not contained in the files with higher priority remain unchanged.

If more than one program has the same title (i.e., the same sheet, action, or transition number), the program is deleted from the files with lower priority, although I/O names and I/O comments remain.

If the same step or transition number is contained in an SFC program, the entire sheet is deleted from the files with lower priority.

I/O Names/I/O Comment Data

I/O names and I/O comments associated with bit addresses which also exist in a program with a higher priority are rewritten to the I/O names and I/O comments of the higher priority program.

I/O names which are also used in a program with higher priority are deleted if they are associated with a different bit address.

User programs, I/O names, and I/O comments cannot be linked if SFC programming is used.

The previous rules are illustrated in the following diagrams.

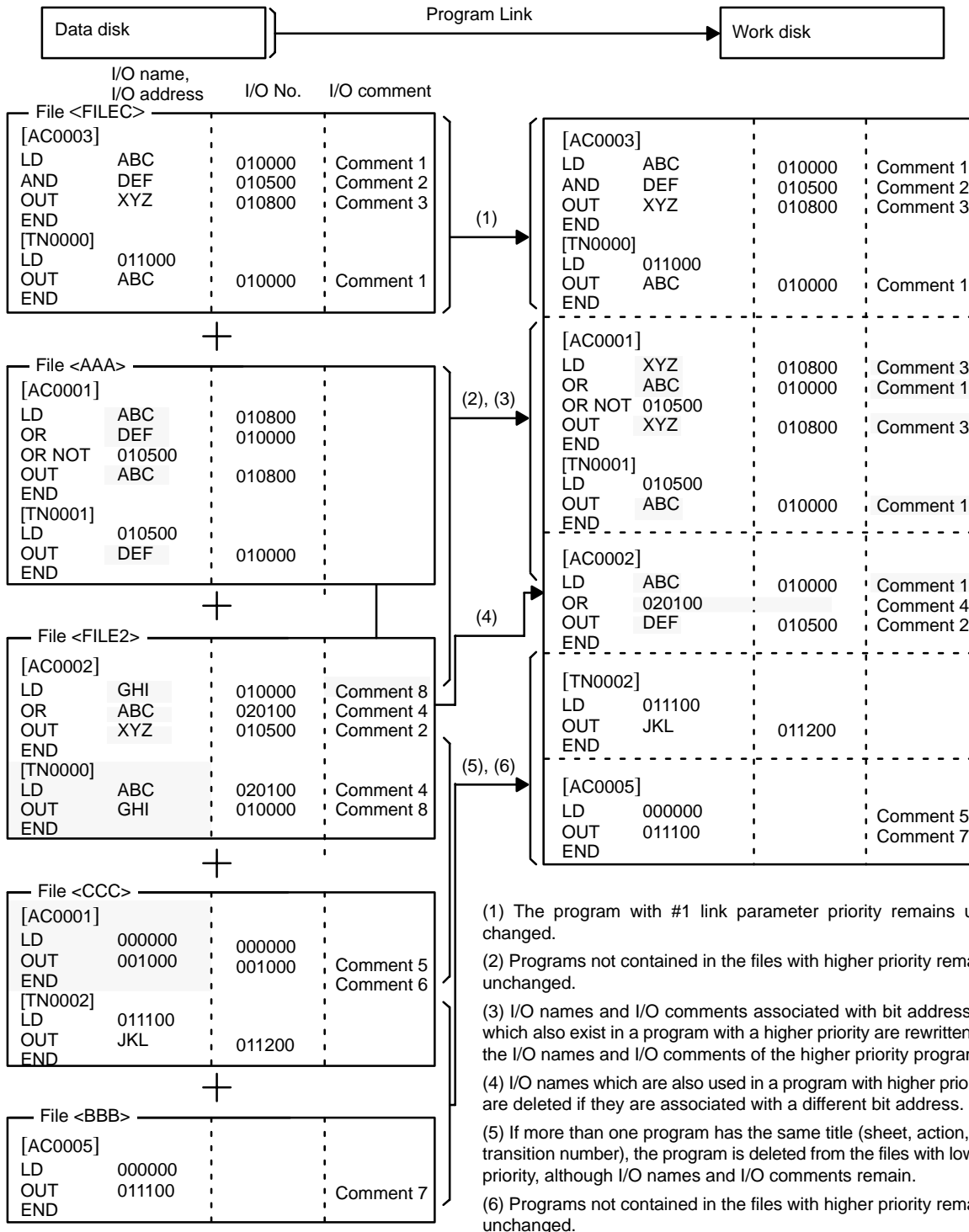

4-3-1 Creating Link Parameters

- 1, 2, 3...**
1. Select "L:Program link" from the main offline menu.
The link parameter editing screen will be displayed.
 2. Enter the files to be linked in the order of priority. Up to 100 file names can be entered.

The insertion mark will flash in the file name input area at the bottom of the screen. Write or edit the file name corresponding to the line selected by the cursor.

If a file contains I/O names or I/O comments, append the suffix SBL or CMT, respectively, to the file name.

Use the PgDn and PgUp Keys to display the previous and next page. Use the Up and Down Keys to move the cursor up and down the rows.

adr	File name
001	
002	
003	
004	
005	
006	
007	
008	
009	
010	
011	
012	
013	
014	
015	

3. Press the Esc Key or Shift+Esc Keys to return to the main menu.

Parameters entered for the program link operations are stored in the main memory. However, parameters displayed on the screen but not saved using the Save link parameters operation will be lost if the main offline menu is displayed, the reset button is pressed, or the power supply is turned off.

A prompt message will be displayed to confirm that the parameters have been saved before the main offline menu is displayed.

Note Enter the file name as up to 8 characters. Lower-case characters are converted to upper-case. A single directory name can have up to 8 characters with a total of 66 characters for the entire path name. The program link operations can link programs in up to 7 levels of directory hierarchy. See 6-2 *File Management* for more information about directories.

Key Operations in the Edit Mode

Operation	Key sequence	Function
Moving to the beginning	F4	Press to show the first page of the display.
Moving to the end	F5	Press to show the last page of the display.
Moving to a specified line number	F6 line_number CR	Press to display data from a specified line number.
Copying	Move cursor F7 move cursor F8 move cursor F10	Press to copy a specified range of file names behind a specified destination line. <ol style="list-style-type: none"> 1. Move the cursor to the start point of the range to be copied and press the F7 Key. 2. Move the cursor to the end point of the range to be copied and press the F8 Key. 3. Move the cursor to the copy destination and press the F10 Key.
Deleting	Move cursor F7 move cursor F9	Press to delete a specified range of file names. <ol style="list-style-type: none"> 1. Move the cursor to the start point of the range to be deleted and press the F7 Key. 2. Move the cursor to the end point of the range to be deleted and press the F9 Key.
Moving file names	Move cursor F7 move cursor F9 move cursor F10	Press to move a specified range of file names behind a specified destination line. <ol style="list-style-type: none"> 1. Move the cursor to the start point of the range to be moved and press the F7 Key. 2. Move the cursor to the end point of the range to be moved and press the F9 Key. 3. Move the cursor to the destination and press the F10 Key.

- Note**
1. Press the Up and Down Keys to move the cursor vertically.
 2. The F8 and F9 Keys are effective only after the F7 Key is pressed.

4-3-2 Link Program Menu

The link program menu can be accessed by pressing the End Key or Ctrl+M Keys on the Edit screen. Select the required operation.

```
[ Link Program ]
M:Link mode
S:Save link parameters
R:Retrieve lnk parameter
C:Clear link parameters
P:Print link parameters
E:Exec link
```

Link Program Menu Operations

Operation	Function
Clear link parameters	Clears the link parameters.
Exec link	Links files on the data disks in the order specified with the link parameters and places the linked program on the work disk.
Link mode	Specifies whether I/O names, I/O comments, and block comments are to be linked.
Print link parameters	Prints a specified range of link parameters.
Retrieve link parameter	Displays the parameter data from the data disk or hard disk.
Save link parameters	Saves the parameter data created on the screen to the data disk or hard disk.

4-3-3 Setting the Link Mode

- 1, 2, 3... 1. Select "M:Link mode" from the main menu. The Link Mode menu will appear.

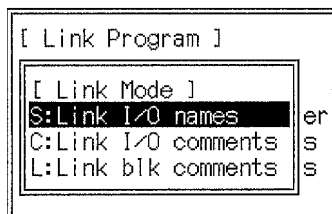

2. Select the operations to set if the I/O names, I/O comments, and block comments are to be linked. Press the Y and Enter Keys to link the selected item or just the Enter not to link it. The settings will be displayed as Y or N at the top-right of the link parameter table.
3. Press the Esc Key to return to the main menu.
 or Press the Shift+Esc Keys to return to the edit screen.

4-3-4 Executing the Link

- 1, 2, 3... 1. Select "E:Exec link" from the main menu. A prompt message will be displayed.
2. Press the Y and Enter Keys to start the program link. The program will be cleared from the work disk.
3. Press the Esc Key to return to the main menu.

The following information will be displayed during the program link execution and error messages will be displayed for each file when the program link is complete.

- Processing file address
- Processing file name

Refer to the table following this procedure for information on the error messages. A message will appear if no errors are found.

4. To continue the link operation, insert the data disk containing the required files and press the Enter Key.
- or Press the N and Enter Keys to cancel the link operation and return to the edit screen.
- A message at the bottom of the screen will indicate when the program link operation is complete.
5. Press the Shift+Esc Keys to return to the edit screen.

or Press the Esc Key to return to the main menu.

The Esc or Shift+Esc Keys can be pressed during the program link operation to cancel. A message will ask if the operation should be cancelled. Press the Y and Enter Keys to cancel the program link operation and then press the Esc Key to return to the main menu.

The time to run the program link depends on the size of the files. It may take over 10 minutes.

Error Message Table

Message	Description	Result
Diff I/O names for same address (address: XXXXXXXX)	The I/O name for the displayed I/O address in a processed file has already been linked. Standardized to the I/O name in the file with the highest priority.	The transition program causing the error will not be linked.
Diff address for same I/O name (I/O name: XXXXXXXX)	The displayed I/O name in a processed file has already been linked. The I/O name is cleared for the I/O address causing the error.	
Diff I/O comments for same address (addr: XXXXXXXX)	The I/O comment for the displayed I/O address in a processed file has already been linked. Standardized to the I/O comment in the file with the highest priority.	
Dup SFC sheet (sheet #: XXXX)	The displayed SFC sheet number in a processed file has already been linked. The SFC program with the sheet number causing the error is not linked. The program with the same sheet number in the file with the highest priority remains in the linked program.	
Dup SFC step (step #: XXXX)	The displayed SFC step number in a processed file has already been linked. The program with the sheet number causing the error is not linked.	
Dup SFC transition (transition#: XXXX)	The displayed SFC transition number in a processed file has already been linked. The program with the sheet number causing the error is not linked.	
Dup ladder program (action #: XXXX)	The program with the displayed action number in a processed file has already been linked. The action program causing the error is not linked. The program with the same action number in the file with the highest priority remains in the linked program.	
Dup ladder program (transition#: XXXX)	The program with the displayed transition number in a processed file has already been linked. The program with the same transition number in the file with the highest priority remains in the linked program.	
SFC program overflow	SFC program too large for the work disk.	The link operation is cancelled and a message will be displayed at the bottom of the screen.
Ladder program overflow	Ladder program too large for the work disk.	The program will be deleted from the work disk.
I/O name file overflow	Too many I/O names registered.	Press the Shift+Esc Keys to return to the edit screen.
I/O comment file overflow	Too many I/O comments registered.	Press the Esc Key to return to the main menu.
Blk comment file overflow	Too many block comments registered or too many block comments for the work disk.	

4-3-5 Saving Link Parameters

- 1, 2, 3...
1. Select "S:Save link parameters" from the main menu.
 2. Input the file name and press the Enter Key.
 3. If the input file name already exists, a message will ask if the file should be overwritten. Press the Y and Enter Keys to overwrite the file. Press the Enter Keys to cancel and input a new file name.
When the Y and Enter Keys are pressed, the link parameter data will be saved on the data disk.

4-3-6 Retrieving Link Parameters

- 1, 2, 3...
1. Select "R:Retrieve link parameters" from the main menu.
 2. Input the file name and press the Enter Key.
To enter a file name, press the End Key or Ctrl+M Keys to display the file names, select the required file name with the cursor, and press the Enter Key.
 3. Press the Enter Key to retrieve the link parameters from the data disk to the work disk.

4-3-7 Clearing Link Parameters

- 1, 2, 3...
1. Select "C:Clear link parameters" from the main menu. A prompt message will be displayed.
 2. Press one of the following set of keys:
 - Press the Y and Enter Keys to clear the link parameters from the screen.
 - Press the N and Enter Keys or the Esc Key to return to the main menu.
 - Press the Shift+Esc Keys to return to the edit screen.

4-3-8 Printing Link Parameters

- 1, 2, 3...
1. Select "P:Print link comments" from the main menu.
 2. Enter the start line number in the range 001 to 100 and press the Enter Key.
 3. Enter the end line and press the Enter Key.
Initially, the value 999 will be displayed. Leave this setting unchanged and press the Enter Key to print to the last line.
 4. Press the Enter Key to start printing.

5. Press the Esc Key to cancel printing and return to the main offline menu. All characters in the print buffer will printed before printing stops.

Parameter List

27/12/91 PAGE = 01

adr	F i l e n a m e
001	19900920
002	16-30
003	B:¥FPC¥19900920
004	B:¥FPC¥16-30
005	AC02
006	AC03
007	AC01
008	AC04
009	AC05
010	ST01
011	ST02
012	ST03
013	PGC2000.SBL
014	PGC500.CMT
015	14141414
016	141513
017	CV.SBL
018	B:¥FPC¥CV¥901201¥ST27

4-4 Editing the Data Memory Area

The following operations are used to enter data to the DM Area as 4-digit hexadecimal or ASCII, to save and retrieve the contents of the DM Area to and from a data disk or hard disk, and to print a memory map of the DM contents.

To access the DM screen, select "D>Edit DM" from the main offline menu. The DM screen will be displayed to enter DM data.

< >

DM HEX

Word	0	1	2	3	4	5	6	7	8	9	Bank #	=Base
00000	0000	0000	0000	0000	0000	0000	0000	0000	0000	0000	
00010	0000	0000	0000	0000	0000	0000	0000	0000	0000	0000	
00020	0000	0000	0000	0000	0000	0000	0000	0000	0000	0000	
00030	0000	0000	0000	0000	0000	0000	0000	0000	0000	0000	
00040	0000	0000	0000	0000	0000	0000	0000	0000	0000	0000	
00050	0000	0000	0000	0000	0000	0000	0000	0000	0000	0000	
00060	0000	0000	0000	0000	0000	0000	0000	0000	0000	0000	
00070	0000	0000	0000	0000	0000	0000	0000	0000	0000	0000	
00080	0000	0000	0000	0000	0000	0000	0000	0000	0000	0000	
00090	0000	0000	0000	0000	0000	0000	0000	0000	0000	0000	
00100	0000	0000	0000	0000	0000	0000	0000	0000	0000	0000	
00110	0000	0000	0000	0000	0000	0000	0000	0000	0000	0000	
00120	0000	0000	0000	0000	0000	0000	0000	0000	0000	0000	
00130	0000	0000	0000	0000	0000	0000	0000	0000	0000	0000	
00140	0000	0000	0000	0000	0000	0000	0000	0000	0000	0000	
00150	0000	0000	0000	0000	0000	0000	0000	0000	0000	0000	

Switching Display Pages

Each page of the screen can display 160 words of DM data from the work disk. Use the following procedures to display the required DM data on the screen.

- 1, 2, 3...**
1. Press the End Key to display the DM menu.
 2. Select the "R:Read DM addr" from the menu and enter the required DM address.
 3. Use the PgDn and PgUp Keys to display the previous and next pages.

Moving the Cursor

Press the Left and Right Keys to move the insertion point along the lines of the display. Use the Up and Down Keys to move the cursor up and down the rows.

Writing Data

- 1, 2, 3...**
1. Move the cursor to the required DM address and enter the data.
Enter data as hexadecimal or ASCII. Hexadecimal will be displayed unchanged as input.
To enter ASCII data, press the End Key and select "A:HEX <-> ASCII" from the menu. Entered data will appear as hexadecimal data in the DM table and ASCII on the right side of the table.
DM data entered in the DM table is simultaneously written to the DM area on the work disk.
 2. Press the Enter Key to move the cursor right to the next DM address. If the cursor is at the right side of the display, it will move to the left end of the next row.
 3. Press the End Key or Ctrl+M Keys to display the following menu on the DM screen.

```
[ D M ]
R:Read DM addr
C:Copy
F:Fill
P:Print
A:HEX <-> ASCII
B:Switch Bank #
S:Save DM
L:Retrieve DM
K:Save file
Y:Retr file
```

4. Select the required operation. These operations are summarized in the following table and described in following sections.

Operation	Function
Copy	Copies multiple, consecutive words of DM data to a specified destination DM address.
FILL	Places a specified value into multiple, consecutive words of the DM area. Filling with 0000 clears the DM words.
HEX <-> ASCII	Sets input to hexadecimal or ASCII. The mode set will be displayed in the top-right of the screen.
Print	Prints multiple, consecutive words of DM data.
Read DM addr	Reads the contents of the DM area, including the specified DM address, from the work disk and displays it in the DM table.
Retr file	Retrieves the file data (with IOM suffix) on the data disk or hard disk to the work disk. Retrieved file data can be edited in the same way as DM data. File data is stored with the suffix IOM.
Retrieve DM	Retrieves the DM data on the data disk or hard disk to the work disk.
Save DM	Saves the DM data from the work disk to the data disk or hard disk.
Save file	Saves the DM data from the work disk to the data disk or hard disk as file data (with IOM suffix).
Switch Bank #	Switches editing between the standard DM and EM banks.

Note The effective DM area capacity on the work disk is 24,576 words for the DM bank and 32,766 words for the EM bank.

4-4-1 Reading a DM Address

- 1, 2, 3...
1. Select "R:Read DM addr" from the DM menu.
 2. Enter the DM address to be read and press the Enter Key. It is not necessary to input the leading zeros (0).
The contents of the DM area will be displayed with the input DM address selected by the cursor.

4-4-2 Copying

- 1, 2, 3...
1. Select "C:Copy" from the DM menu.
 2. Enter the copy source address, the number of words to copy, and copy destination address and press the Enter Key.
The specified number of DM words from the copy source address will be copied to just after the destination address.
Make sure that the destination is not in the within the source words.

4-4-3 FILL

- 1, 2, 3...
1. Select "F: Fill" from the DM menu.
 2. Enter the start address, the end address, and fill data and press the Enter Key. Input the fill data in hexadecimal. It is not necessary to input the leading zeros (0).
The specified fill data will be copied to every word from the specified start address to the end address.

Clearing the DM Area

The initial values when "F:Fill" is selected are 00000 for the start address, 24575

for the end address (32765 when editing the EM Area), and 0000 for the fill data. Leave these settings unchanged and press the Enter Key three times to clear the entire DM or EM Area by writing 0000 to it.

4-4-4 Printing

- 1, 2, 3...
1. Select "P:Print" from the DM menu.
 2. Enter the print start address and the print end address then press the Enter Key. It is not necessary to input the leading zeros (0).
 3. Press the Enter Key to start printing.

The initial values are 00000 for the start address and 24575 for the end address (32765 when editing the EM Area). Leave these settings unchanged and press the Enter Key twice to print the entire contents of the DM or EM Area.

A message will be displayed during the printing operation and will disappear when printing is complete.

4. Press the Esc Key to cancel printing and return to the main menu.

All characters in the print buffer will be printed before printing stops.

Sample Print-out

< < < DM List > > > 27/12/91 PAGE = 001

Wd	0	1	2	3	4	5	6	7	8	9	ASCII Disp
00000	0765	0654	0000	0000	0000	0000	0000	0000	0000	0000	.e .T
00010	0000	0000	0000	0000	0000	0000	0000	4567	0000	0000 Eg
00020	0000	0000	0000	0000	0000	0000	0000	0000	0000	0000
00030	0000	0000	0023	0000	9887	0000	0005	0000	5678	0000 # Vx
00040	0000	0000	0000	0000	0000	0000	0000	0010	0000	0000
00050	0000	0000	0000	0000	0000	0000	0000	0000	0000	0000
00060	4E6D	0000	0007	0000	0000	0000	5234	0000	0000	0000	Nm R4
00070	0000	0000	0000	0000	0000	0000	0000	0000	0000	0000
00080	0000	0000	0E4C	0000	0000	0123	0000	0000	0000	0000 L #
00090	0000	0000	0000	0000	0000	0000	0345	0000	0000	0000 E
00100	0000	0000	0000	0000	0000	0000	0000	0000	0000	0000
00110	0000	0653	0000	0000	0000	0000	A34E	0000	0000	0000	. . . S N
00120	0000	0000	0876	0000	0000	0000	0000	0000	0000	0000	. . . v
00130	0000	0000	0000	0000	0000	0000	0000	0000	0000	0000
00140	0000	0000	0000	0432	0000	0000	3438	0000	0000	0000 2 48
00150	0000									

4-4-5 HEX-ASCII

Select the "A:HEX <-> ASCII" from the main menu to switch DM data input between hexadecimal and ASCII. The input mode changes each time this item is selected and the current mode will be displayed at the top-right of the screen.

Input 4-digit hexadecimal value when HEX is displayed.

Input ASCII when ASCII is displayed.

ASCII Table

	0	1	2	3	4	5	6	7	8	9	A	B	C	D	E	F
0			0	@	P	‘	p		É	á	⋮	L	⋮	α		
1		!	1	A	Q	a	q		∞	í	⋮	⊥	⊥	β		
2		“	2	B	R	b	r	é	Æ	ó	⋮	⊥	⊥	Γ		
3		#	3	C	S	c	s	â	ô	ú	⋮	⊥	⋮	π		
4		\$	4	D	T	d	t	ä	ö	ñ	⋮	⊥	⊥	Σ		
5		%	5	E	U	e	u	à	ò	ñ	⋮	⊥	⊥	F	σ	
6		&	6	F	V	f	v		û	á	⋮	⊥	⊥	μ		
7		'	7	G	W	g	w		ù	ó	⋮	⊥	⊥	γ		
8		(8	H	X	h	x	ê	ÿ	ç	⋮	⊥	⊥	⊥		
9)	9	I	Y	i	y	ë	Ö	Γ	⋮	⊥	⊥	⊥		
A		*	:	J	Z	j	z	è	Ü	⋮	⋮	⊥	⊥	⊥	Ω	
B		+	;	K	[k	l	ï	φ	½	⋮	⊥	⊥	⊥	⊥	
C		,	<	L	\	l	l	î	£	¼	⋮	⊥	⊥	⊥		
D		-	=	M]	m	l	ï	¥	ì	⋮	⊥	⊥	⊥		
E		.	>	N	^	n	~	Ä	ℙ	«	⋮	⊥	⊥	⊥		
F		/	?	O	_	o	△	Â	f	»	⋮	⊥	⊥	⊥		

4-4-6 Switching Memory Banks

During offline operation, only the DM Area or the EM banks can be selected.

- 1, 2, 3... 1. Select "B:Switch Bank #" from the DM menu.
2. Press the 0 and Enter Keys to edit the EM bank 0. Numbers 1 to 7 can be input instead to edit the other EM banks.
 Only a single EM bank can be edited at one time. To edit more than one bank, save each edited EM bank to a data disk before editing the next EM bank.
3. Press the B and Enter Keys to switch from the EM bank to the DM bank.

4-4-7 Saving DM Data

Insert the data disk in the drive. Be sure the data disk has been formatted and is not write-protected. DM data cannot be saved if it exceeds the free space available on the data disk.

The procedure to save DM data is described below, using the data disk as an example.

- 1, 2, 3... 1. Select "S:Save DM" from the DM menu.
2. Enter the file name press the Enter Key.
 To enter an existing file name, press the End Key or Ctrl+M Keys to display the current file names, select the required file name with the cursor, and press the Enter Key.
3. If the input file name already exists, a message will ask if the file should be overwritten. Press the Y and Enter Keys to overwrite the file. Press the Enter Key to cancel and input a new file name.
 The title input area will appear when the Enter Key is pressed.

4. Input the title and press the Enter Key.
The title can be up to 30 characters long.
5. Press the Enter Key to save the DM data. The DM screen will be displayed after the DM data is saved.

Note Enter the file name as up to 8 characters. Lower-case characters are converted to upper-case. A single directory name can have up to 8 characters with a total of 66 characters for the entire path name. See *6-2 File Management* for more information about directories.

4-4-8 Retrieving DM Data

Insert the data disk containing the DM data in the drive.

- 1, 2, 3...
 1. Select "L:Retrieve DM" from the DM menu.
 2. Press the End Key or Ctrl+M Keys to display the file names.
 3. Select the required file name with the cursor and press the Enter Key.
The file name will be displayed.
 4. Press the Enter Key to retrieve the DM data.
The DM screen will be displayed after the DM data is retrieved.

4-4-9 Saving File Data

Insert the data disk in the drive. Be sure the data disk has been formatted and is not write-protected. DM data cannot be saved if it exceeds the free space available on the data disk.

- 1, 2, 3...
 1. Select "K:Save file" from the DM menu. The following display will appear.

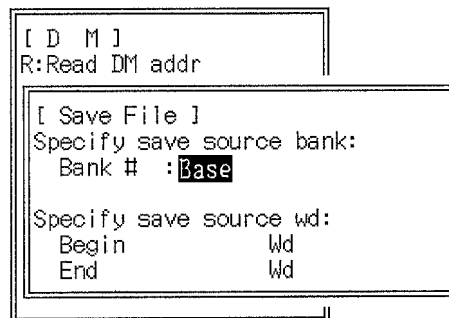

2. Enter the source bank address and press the Enter Key.
If the DM editing screen is already displayed, press the Enter Key to save the file data.
If the EM editing screen is currently displayed, press any one of the numerical keys (0 to 7).
3. Enter the save start address and press the Enter Key.
The save start address is the DM address being edited.
4. Enter the file name and press the Enter Key.
To enter an existing file name, press the End Key or Ctrl+M Keys to display the current file names, select the required file name with the cursor, and press the Enter Key.
5. If the input file name already exists, a message will ask if the file should be overwritten. Press the Y and Enter Keys to overwrite the file. Press the Enter Key to cancel and input a new file name.
6. Press the Enter Key to save the file data.
The DM screen will be displayed after the DM data is saved.

4-4-10 Retrieving File Data

Insert the data disk containing the saved file data in the drive.

- 1, 2, 3... 1. Select "Y:Retr file" from the DM menu. The following display will appear.

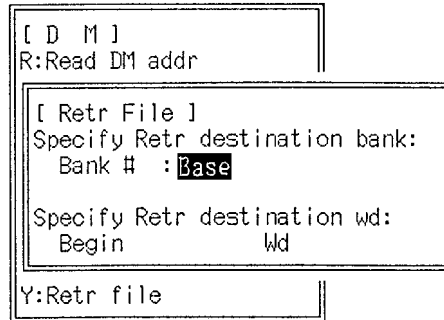

2. Enter the destination bank address and press the Enter Key.
If the DM editing screen is already displayed, press the Enter Key to retrieve the file data.
If the EM editing screen is currently displayed, press any of the numerical keys (0 to 7).
3. Enter the destination start address and press the Enter Key.
The destination start address is the DM address being edited.
Use the following procedure to input the file name to be retrieved:
Press the End Key or Ctrl+M Keys to display the file names.
Select the required file name with the cursor and press the Enter Key.
4. Press the Enter Key to retrieve the file data. The DM screen will be displayed after the DM data is retrieved.

4-5 Editing the I/O Table

The following operations can be used to create and edit the I/O table at the computer and store it in the work disk, to check that the I/O table is correct, to save and retrieve the contents of the I/O table to and from a data disk or hard disk, and to set the parameters in the PC Setup that relate to the I/O table.

Select "I>Edit I/O table" from the main offline menu. The contents of the Basic Racks will be displayed from the I/O table. From this display the I/O table edit menu and displays for the rest of the I/O table can be accessed and the table can be edited.

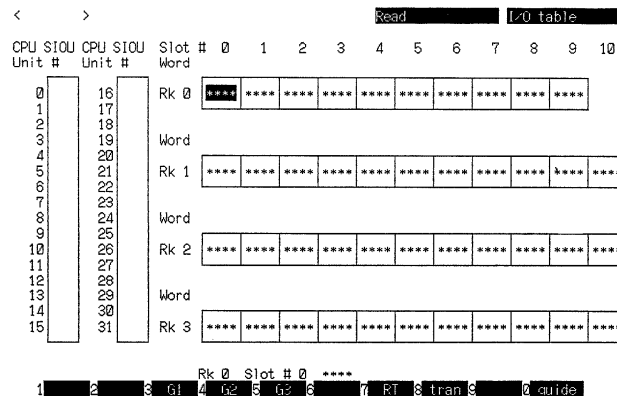

Press the PgDn and PgUp Keys to display the previous and next contents of the Basic Racks. Press the Shift+Left Keys or the Shift+Right Keys to move the cursor between the Basic Rack screen area and CPU Bus Unit display area.

When the cursor is located at a Remote I/O Master Unit (RM) in the CPU Bus Unit display area, press the F3 to F5, F7, or F8 Keys to switch to the Slave display areas shown in the following table.

Key Operations

Key	Display	Function	Operation
F3	Group-1 Slaves	Displays group-1 Slaves connected to the SYSMAC BUS/2 Master.	Move the cursor to the Master in the CPU Bus Unit display area and press the required function key.
F4	Group-2 Slaves	Displays group-2 Slaves connected to the SYSMAC BUS/2 Master.	
F5	Group-3 Slaves	Displays group-3 Slaves (Slave Rack) connected to the SYSMAC BUS/2 Master.	
F7	C-series Slave Racks	Displays the Slave Rack connected to the SYSMAC BUS Master	Move the cursor to the Master in the Basic Rack display area and press the required function key.
F8	I/O Terminals	Displays the I/O Terminals and I/O Link Units connected to a SYSMAC BUS Master	
F10	Help screen	Displays a key to the symbols used to display the I/O table.	Display from any screen.
Esc	Basic Racks	Press the Esc Key after any of the above function keys to return to the Basic Rack screen.	

Press the End Key or Ctrl+M Keys to display the following menu on the I/O table display, and select the required operation. These operations are described in more detail in following sections.

```
[ Edit I/O Table ]
W:Write I/O table
K:Check I/O table
S:Save I/O table
L:Retrieve I/O table
C:Clear I/O table
Z:Custom I/O table SIOU
A:PC setup
```

Operation	Function
Write I/O table	Used to write and edit the I/O table on the work disk.
Check I/O table	Checks the contents of the I/O table on the work disk and displays errors if detected.
Save I/O table	Saves the I/O table contents on the work disk and the first words set in the PC Setup to the data disk or hard disk.
Retrieve I/O table	Retrieves the I/O table contents from the data disk or hard disk to the work disk.
Clear I/O table	Clears the I/O table data from the work disk.
Custom I/O table SIOU	Registers the types of CPU Bus Units. Not used at present.
PC setup	Sets or changes the first words for the Basic Racks, Slave Racks, group-1 Slaves, group-2 Slaves, and I/O Terminals.

4-5-1 Writing I/O Tables

The following display will appear when "W:Write I/O table" is selected from the Edit I/O table menu. This operation is used when a PC System does not yet exist or to check allocations in an existing table.

Basic (Local) Racks

Write I/O table

CPU Unit #	SIU Unit #	CPU Unit #	SIU Unit #	Slot	0	1	2	3	4	5	6	7	8	9	10
0	16			Rk 0	****	****	****	****	****	****	****	****	****	****	****
1	17			Rk 1	****	****	****	****	****	****	****	****	****	****	****
2	18			Rk 2	****	****	****	****	****	****	****	****	****	****	****
3	19			Rk 3	****	****	****	****	****	****	****	****	****	****	****
4	20			Rk 4	****	****	****	****	****	****	****	****	****	****	****
5	21			Rk 5	****	****	****	****	****	****	****	****	****	****	****
6	22			Rk 6	****	****	****	****	****	****	****	****	****	****	****
7	23			Rk 7	****	****	****	****	****	****	****	****	****	****	****
8	24														
9	25														
10	26														
11	27														
12	28														
13	29														
14	30														
15	31														

1 2 4 8 b 4 N 6 7 62 8 63 9 SIU 0 aride

- 1, 2, 3...** 1. Enter the I/O table data with the function keys (see *Function Keys* table below).

Use the Up, Down, Left, and Right Keys to move the cursor around the displayed area.

Press the Shift+Left Keys to move the cursor from the Basic Rack display area to the CPU Bus Unit display area and from the CPU Bus Unit display area back to the Basic Rack display area.

Rack 0 is the CPU Rack. Rack 1 to Rack 7 are assigned to the other Basic Racks by user settings on the I/O Interface Units.

2. Whatever part of the I/O table is being edited, press the Shift+F10 Keys from the Basic Rack screen to save data to the work disk.

To save data for group-1 Slaves, group-2 Slaves, group-3 Slaves, SYSMAC BUS Slaves, or I/O Terminals, press the Shift+F10 Keys to display the Basic Rack screen, and then press the Shift+F10 Keys again to write the I/O table to the work disk.

If the Shift+F10 Keys are not pressed from the Basic Rack screen, the entries for the BASIC Units, group-1 Slaves, group-2 Slaves, group-3 Slaves, SYSMAC BUS Slaves, or I/O Terminals will be lost.

A confirmation message will be displayed after the Shift+F10 Keys are pressed from the Basic Rack screen.

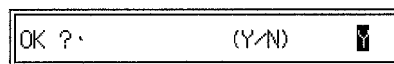

3. Press the Enter Key to check the input I/O table and write it to the work disk if no errors are found.

An error message table will be displayed if errors are found. The errors are displayed on separate pages of the error message table for the BASIC Units, SYSMAC BUS Slaves, Group-1/2/3 Slaves, I/O Terminals, and CPU Bus Unit. Press the PgDn to scroll down the error message table and the PgUp Key to return to the previous page. The errors for the I/O Terminals are the last page of the error message table.

4. Correct the errors and press the Shift+F10 Keys again.
5. Press the Esc Key to return to the original screen.

Refer to the table on page 167 for information on the error messages.

Function Keys

Function key	Name	Display after input	Function
F1	o	o	Enters an Output Unit. Each o indicates 8 outputs.
F2	O	O	Enters an Output Unit. Each O indicates 16 outputs. In the case of the I/O Remote Unit, a O stands for 8 output points.
F3	G	G	Enters an Output Unit with 128 or more outputs. Each G indicates 64 outputs.
F5	N	N	Reserves a word. Each N represents 16 I/O.
F6	G1	---	Displays the I/O table for the group-1 Slaves connected to a SYSMAC BUS/2 Master. Move the cursor to the Master in the CPU Bus Unit display area and press the F6 Key.
F7	G2	---	Displays the I/O table for the group-2 Slaves connected to a SYSMAC BUS/2 Master. Move the cursor to the Master in the CPU Bus Unit display area and press the F7 Key.
F8	G3	---	Displays the I/O table for the group-3 Slaves connected to a SYSMAC BUS/2 Master. Move the cursor to the Master in the CPU Bus Unit display area and press the F8 Key.
F9	SIOU	---	Enters CPU Bus Units in the CPU Bus Unit display area.
F10	Guide	---	Displays a key to the symbols used on the display. Press the Esc Key to clear the help screen.
Shift+F1	i	i	Enters an Input Unit. Each i indicates 8 inputs.
Shift+F2	l	l	Enters an Input Unit. Each l indicates 16 inputs. In the case of the I/O Remote Unit, a l stands for 8 input points.
Shift+F3	L	L	Enters an Input Unit with 128 or more inputs. Each L indicates 64 inputs.
Shift+F5	H	H	Reserves 128 I/O. Each H represents 64 I/O.
Shift+F6	RT	---	Displays the I/O table for Slaves connected to a SYSMAC BUS Master. Move the cursor to the Master in the Basic Rack display area and press the Shift+F6 Keys.
Shift+F7	Tran	---	Displays the I/O table for I/O Terminals and I/O Link Units connected to a SYSMAC BUS Master. Move the cursor to the Master in the Basic Rack display area and press the Shift+F7 Keys.
Shift+F8	Intr	INT	Enters an Interrupt Input Unit. Only 4 Interrupt Input Units are supported per PC. Set the Interrupt Input Units on the CPU Rack (rack #0) or Expansion CPU Rack (rack #1). The unit numbers of the Interrupt Input Units are automatically allocated in the order the units are mounted.
Shift+F9	RM	RM	Enters a SYSMAC BUS Master. Up to 8 Masters can be used on the Basic Racks. The Master numbers are automatically determined in the order the units are attached.

Function key	Name	Display after input	Function
Shift+F10	End	---	<p>Press the Shift+F10 Keys from any other screen to return to the Basic Rack screen.</p> <p>Press the Shift+F10 Keys from the Basic Rack screen to check the input I/O table created on-screen and save it to the work disk if no errors are found.</p> <p>The I/O table will not be written to the work disk and an error message table will be displayed if errors are found. Press the Esc Key to return to the original screen. Correct the errors and press the Shift+F10 Keys again.</p>
Home	Clear	****	<p>Clears the allocation displayed at the cursor position. Press the Shift+F10 Keys from the Basic Rack screen to save the changes.</p>

Allocations Required for C-series Special I/O Units

Model	Allocations	Model	Allocations
C500-ID212	Not classified as Special I/O Units	IIII	C500-NC103 (See Note 4)
C500-OD211		O000	C500-NC111-V1
C500-MD211CN		O **	C500-NC121 (See Note 4)
C500-AD001 to 005		II**	C500-NC221
C500-AD006/007		IIII	C500-CP131 (See Note 3)
C500-AD101 (See Note 3)		O **	C500-OV001
C500-DA001 to 005		OO**	C500-ASC04 (See Note 3)
C500-DA101		O000	C500-IDS01-V1/02/21/22 (See Note 3)
C500-CT001		O0II	C500-LD211
C500-CT012		O **	C500-LDP01-V1
C500-MGC01		O0II	C500-ASP01/02 (See Note 3)
C500-PID01 (See Note 4)		O0II	C500-GDI11/12 (See Note 3)

- Note**
- Up to 8 Special I/O Units can be connected to each Rack unless a single Expansion I/O Rack is connected directly to the CPU Rack (i.e., without an I/O Interface Unit), in which case a total of 8 Special I/O Units can be mounted to both Racks.
 - The I/O READ/WRITE instructions, READ(190)/WRIT(191), cannot be used for Special I/O Units mounted on Slave Racks.
 - Allocations will be displayed as "00II" when the I/O READ/WRITE instructions are disabled.
 - Two slots are required for NC103, NC121, and PID01. When allocating words, allocate the words to the left of the two slots and leave the right slot blank.
 - The following Units cannot be mounted on SYSMAC BUS/2 Slave Racks: NC121, PID01, MGC01, and ASP01/02.

Slave Limitations

The number of each type of Slave that can be connected is shown in the following table.

Item		SYSMAC BUS/2		SYSMAC BUS (C Series)	
		CV500-CPU01-E CVM1-CPU01-E	CV1000-CPU01-E CV2000-CPU01-E CVM1-CPU11-E	CV500-CPU01-E CVM1-CPU01-E	CV1000-CPU01-E CV2000-CPU01-E CVM1-CPU11-E
Max. per PC	Remote I/O points	1,024 (64 words)	2,048 (128 words)	512 (32 words)	1,024 (64 words)
	Masters	2	4	4	8
	Slave Racks	---	---	8	16
Max. per Master	Slaves (see Note 1)	58M + 122M +54MH: 8 Count each 122M and 54MH as 2; each 58M as 1.		2	8
	Remote I/O points	58M: 464 inputs/454 outputs 122M: 976 inputs/976 outputs 54MH: 432 inputs/432 outputs		512 (32 words)	
	Remote I/O Slave Units, I/O Link Units, I/O Terminals	---		Optical Systems: 64 Wired Systems: 32	

Note Use the switches on the Remote I/O Slave Unit to set 58M, 122M, or 54MH.

Help Screen

Press the F10 Key to display the help screen. Press the Esc Key the hide the help screen.

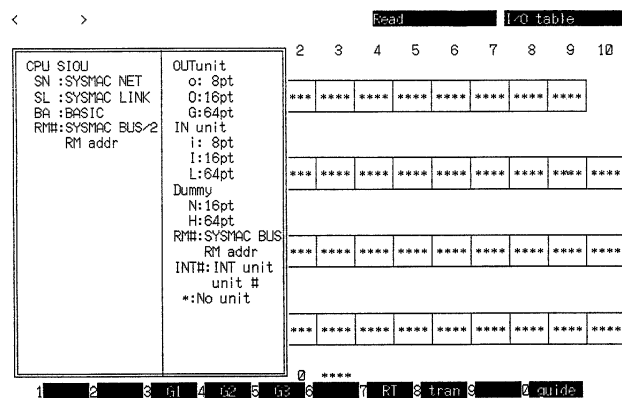

Entering CPU Bus Units

- 1, 2, 3... 1. Press the Shift+Left Keys to move the cursor to the CPU Bus Unit display area.
2. Move the cursor to the required unit number in the CPU Bus Unit display area.

- Press the F9 Key. The unit number that is displayed is set with the switch on the CPU Bus Unit.

CPU S Unit	CPU SIOU				CU Special I/O							
	#	SIOU ID	#	SIOU ID	#	SIOU ID	OUT	IN	#	SIOU ID	OUT	IN
0	0	SN	16		0				16			
1	1	SL	17		1				17			
2	2	RM	18		2				18			
3	3	BA	19		3				19			
4	4	UP	20		4				20			
5	5	SM	21		5				21			
6	6	LK	22		6				22			
7	7		23		7				23			
8	8		24		8				24			
9	9		25		9				25			
10	10		26		10				26			
11	11		27		11				27			
12	12		28		12				28			
13	13		29		13				29			
14	14		30		14							
15	15		31		15							

Units in the display are identified with the following abbreviations.

- SN: SYSMAC NET Link Unit
- SL: SYSMAC LINK Unit
- RM: SYSMAC BUS/2 Master
- BA: BASIC Unit
- VP: Personal Computer Unit
- LK: Host Link Unit

- Move the cursor to the units to be set and press the Enter Key. The Units that are set will appear in the CPU Bus Unit display area. The SYSMAC BUS/2 Masters are allocated Master addresses 0 to 3 sequentially from the unit with the lowest unit number. The numbers display in the table are independent from the unit numbers. The CV Special I/O column is not used at present.
- Press the Shift+F10 and Enter Keys from the Basic Rack screen to save the settings.

Entering SYSMAC BUS/2 Group-1 Slaves

- 1, 2, 3... Move the cursor on the CPU Bus Unit display area to select a Master from RM0 to RM3 to which group-1 Slaves are to be connected and press the F6 Key. The group-1 Slave table will be displayed.

Unit #	0	1	2	3	4	5	6	7	8	9
0	****	****	****	****	****	****	****	****	****	****
10	****	****	****	****	****	****	****	****	****	****
20	****	****	****	****	****	****	****	****	****	****
30	****	****								

- Create the table, as described for the Basic Racks. Unit numbers are set on the Units.
- When all required allocations have been entered, press the Shift+F10 Keys to return to the Basic Rack screen then press the Shift+F10 and Enter Keys

to check and save the settings. The set values will be lost if the Shift+F10 and Enter Keys are not pressed from the Basic Rack screen.

An error message table will be displayed if any errors are discovered in the I/O table settings after the Shift+F10 and Enter Keys are pressed. The errors are displayed on separate pages of the error message table for the BASIC Units, SYSMAC BUS Slaves, Group-1/2/3 Slaves, I/O Terminals, and CPU Bus Unit. Press the PgDn to scroll down the error message table and the PgUp Key to return to the previous page. The errors for the I/O Terminals are the last page of the error message table.

4. Press the Esc Key to return to the original screen. Correct the errors and press the Shift+F10 Keys again.

Refer to the table on page 167 for information on the error messages.

Entering SYSMAC BUS/2 Group-2 Slaves

- 1, 2, 3... 1. Move the cursor on the CPU Bus Unit display area to select a Master from RM0 to RM3 to which group-2 Slaves are to be connected and press the F7 Key. The group-2 Slave table will be displayed.

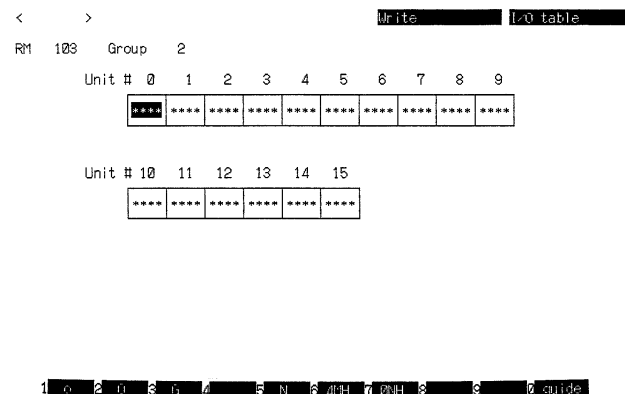

2. Create the table, as described for the Basic Rack. Unit numbers are set on the Units.
3. When all required allocations have been entered, press the Shift+F10 Keys to return to the Basic Rack screen then press the Shift+F10 and Enter Keys to check and save the settings. The set values will be lost if the Shift+F10 and Enter Keys are not pressed from the Basic Rack screen.

An error message table will be displayed if any errors are discovered in the I/O table settings after the Shift+F10 and Enter Keys are pressed. The errors are displayed on separate pages of the error message table for the BASIC Units, SYSMAC BUS Slaves, Group-1/2/3 Slaves, I/O Terminals, and CPU Bus Unit. Press the PgDn to scroll down the error message table and the PgUp Key to return to the previous page. The errors for the I/O Terminals are the last page of the error message table.

4. Press the Esc Key to return to the original screen. Correct the errors and press the Shift+F10 Keys again.

Refer to the table on page 167 for information on the error messages.

Entering SYSMAC BUS/2 Group-3 Slaves

- 1, 2, 3... 1. Move the cursor on the CPU Bus Unit display area to select a Master from RM0 to RM3 to which group-3 Slaves are to be connected and press the F8 Key. The group-3 Slave table will be displayed.

Write I/O table

RM1 204 Group 3

Slot	0	1	2	3	4	5	6	7	8	9	10
RT-0	< >										
RT-1	< >										
RT-2	< >										
RT-3	< >										
RT-4	< >										
RT-5	< >										
RT-6	< >										
RT-7	< >										

1 0 2 0 8 6 4 8 N 6 0 8 8 9 SITE 0 guide

2. Create the table, as described for the Basic Racks. Unit numbers are set on the Unit.
3. To set the Slave type (58M, 122M, 54MH) press the corresponding key combination: Shift+F7 to F9.
 The selected type will be displayed in the brackets < > to the left of the table.
 The Slave number and Slave type are set with the switches on the Remote I/O Slave Unit.
 Press the Shift+F6 Keys to clear all data from the row of data currently selected by the cursor.
 The F9 Key is not used at present.
4. When all required allocations have been entered, press the Shift+F10 Keys to return to the Basic Rack screen then press the Shift+F10 and Enter Keys to check and save the settings. The set values will be lost if the Shift+F10 and Enter Keys are not pressed from the Basic Rack screen.
 An error message table will be displayed if any errors are discovered in the I/O table settings after the Shift+F10 and Enter Keys are pressed. The errors are displayed on separate pages of the error message table for the BASIC Units, SYSMAC BUS Slaves, Group-1/2/3 Slaves, I/O Terminals, and CPU Bus Unit. Press the PgDn to scroll down the error message table and the PgUp Key to return to the previous page. The errors for the I/O Terminals are the last page of the error message table.
5. Press the Esc Key to return to the original screen. Correct the errors and press the Shift+F10 Keys again.

Refer to the table on page 167 for information on the error messages.

Entering SYSMAC BUS Slaves

1. Move the cursor on the Basic Rack display area to select a Master from RM0 to RM7 to which Slaves are to be connected and press the Shift+F6 Keys. The Slave I/O table will be displayed.

Write I/O table

RM 1

Slot	0	1	2	3	4	5	6	7
RT-0	****	****	****	****	****	****	****	****
RT-1	****	****	****	****	****	****	****	****
RT-2	****	****	****	****	****	****	****	****
RT-3	****	****	****	****	****	****	****	****
RT-4	****	****	****	****	****	****	****	****
RT-5	****	****	****	****	****	****	****	****
RT-6	****	****	****	****	****	****	****	****
RT-7	****	****	****	****	****	****	****	****

1 0 2 U 3 4 5 N 6 7 8 9 guide

2. Create the table, as described for the Basic Racks. Slave numbers are set on the Remote I/O Slave Unit.
3. When all required allocations have been entered, press the Shift+F10 Keys to return to the Basic Rack screen then press the Shift+F10 and Enter Keys to check and save the settings. The set values will be lost if the Shift+F10 and Enter Keys are not pressed from the Basic Rack screen.

An error message table will be displayed if any errors are discovered in the I/O table settings after the Shift+F10 and Enter Keys are pressed. The errors are displayed on separate pages of the error message table for the BASIC Units, SYSMAC BUS Slaves, Group-1/2/3 Slaves, I/O Terminals, and CPU Bus Unit. Press the PgDn to scroll down the error message table and the PgUp Key to return to the previous page. The errors for the I/O Terminals are the last page of the error message table.

4. Press the Esc Key to return to the original screen. Correct the errors and press the Shift+F10 Keys again.

Refer to the table on page 167 for information on the error messages.

Entering I/O Terminals

1, 2, 3...

1. Move the cursor on the Basic Rack display area to select a Master from RM0 to RM7 to which I/O Terminals are to be connected and press the Shift+F7 (tran) Keys. The I/O Terminal table will be displayed.

Write I/O table

RM 2 Tran

Word 2364	2365	2366	2367	2368	2369	2370	2371
□*	**	**	**	**	**	**	**
Word 2372	2373	2374	2375	2376	2377	2378	2379
**	**	**	**	**	**	**	**
Word 2380	2381	2382	2383	2384	2385	2386	2387
**	**	**	**	**	**	**	**
Word 2388	2389	2390	2391	2392	2393	2394	2395
**	**	**	**	**	**	**	**

1 0 2 U 3 4 5 N 6 7 8 9 guide

2. Create the table, as described for the Basic Rack. Press the F2 Key in the case of (O) 8 output points or the Shift+F2 Keys in the case of (I) 8 input points. Unit numbers are set on the I/O Terminal or I/O Link Units.

Do not mix inputs and outputs within the same word.

The I/O Link Units are set in units of 16 points; enter two symbols for 8 points in the same word.

The "16-point input/16-point output" setting is not used when an I/O Link Unit is connected to a CV-series PC.

3. When all required allocations have been entered, press the Shift+F10 Keys to return to the Basic Rack screen then press the Shift+F10 and Enter Keys to check and save the settings. The set values will be lost if the Shift+F10 and Enter Keys are not pressed from the Basic Rack screen.

An error message table will be displayed if any errors are discovered in the I/O table settings after the Shift+F10 and Enter Keys are pressed. The errors are displayed on separate pages of the error message table for the BASIC Units, SYSMAC BUS Slaves, Group-1/2/3 Slaves, I/O Terminals, and CPU Bus Unit. Press the PgDn to scroll down the error message table and the PgUp Key to return to the previous page. The errors for the I/O Terminal are the last page of the error message table.

4. Press the Esc Key to return to the original screen. Correct the errors and press the Shift+F10 Keys again.

Refer to the table on page 167 for information on the error messages.

4-5-2 Checking I/O Tables

The following operation is used to check the I/O table on the work disk and display any errors found. Conduct this check when transferring an I/O table created via the PC to the computer.

This check is conducted automatically if the I/O table is written using the Write I/O table operation.

- 1, 2, 3... 1. Select "K:Check I/O table" from the I/O Table menu. The contents of the I/O table will be checked and a message will be displayed if an errors are detected.

The errors are displayed on separate pages of the error message table for the BASIC Units, SYSMAC BUS Slaves, Group-1/2/3 Slaves, I/O Terminals, and CPU Bus Unit.

2. Press the PgDn to scroll down the pages of the error message table and the PgUp Key to return to the previous page. Refer to the following table for information on the error messages.
3. Change the I/O table to match the actual units connected using the Create I/O table operations.

Error Messages

If an error is detected when the I/O table is checked, one of the error messages below will appear in the error message table. Take the following measures to correct the error:

If the table was written via CVSS:

Press the Esc Key to return to the previous screen and edit the I/O table.

If the table was generated via the PC:

Change the I/O table to match the actual units connected, using the Create I/O table operations.

Error message	Error description	Remedy
# error	The total number of I/O points exceeds the limit.	Change settings to bring the total number of I/O points below the limit.
Dup unit #	Duplicate unit numbers for CPU Bus Units.	Change settings so that the same unit number is not used twice.
Dup word	Duplicate word allocations.	Change settings so that the same word is not allocated twice.
Excess units	The total number of Units exceeds the prescribed limit.	Change settings to bring the total number of Units below the limit.
High address	An address is set out of range.	Change the settings to bring all addresses within the prescribed ranges.
High total words	The total number of words exceeds the limit.	Change settings to bring the total number of words below the limit.
IN/OUT mix	Both inputs and outputs used in the same word of a I/O Terminal.	Change the settings so that only inputs or only outputs are used in a single words.
Intr unit posi err	An Interrupt Input Unit has been allocated to Rack other than the CPU Rack (rack #0) or Expansion CPU Rack (rack #1).	Move the Interrupt Input Unit to the CPU Rack or Expansion CPU Rack. Set the Expansion CPU Rack to rack #1.
Undefined RM	Master not recognized by the CPU.	Correct the I/O table.

4-5-3 Saving I/O Tables

Insert a data disk into the drive. It is recommended that the user program and I/O table be written as a set to the same data disk.

Be sure the data disk has been formatted and is not write-protected. I/O table data cannot be saved if it exceeds the free space available on the data disk.

The following display will appear when "S:Save I/O table" is selected from the Edit I/O Table menu.

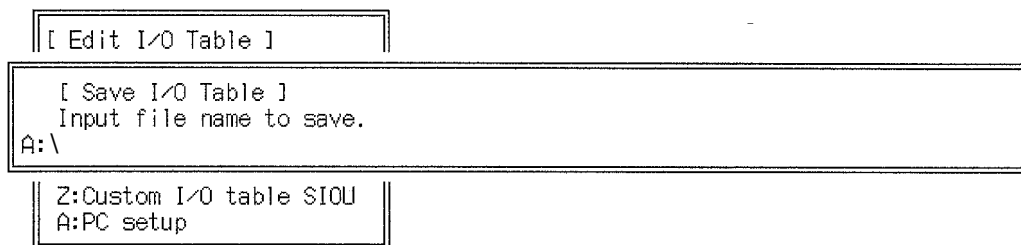

- 1, 2, 3... 1. Enter the file name and press the Enter Key.
To enter an existing file name, press the End Key or Ctrl+M Keys to display the current file names, select the required file name with the cursor, and press the Enter Key.
2. If the input file name already exists, a message will ask if the file should be overwritten. Press the Y and Enter Keys to overwrite the file, or press the Enter Key to cancel and input a new file name.
The title input area will appear when the Enter Key is pressed.
3. Input the title and press the Enter Key.
The title can be up to 30 characters long.
4. Press the Enter Key to save the I/O table data. The I/O table editing screen will be displayed after the data is saved.
The settings made in the PC Setup from the Edit I/O Table menu are saved simultaneously.

Note Enter the file name as up to 8 characters. Lower-case characters are converted to upper-case. A single directory name can have up to 8 characters with a total of

66 characters for the entire path name. See *6-2 File Management* for more information about directories.

4-5-4 Retrieving I/O Tables

- 1, 2, 3...
1. Insert the data disk containing the I/O table data into the drive.
 2. Select "L:Retrieve I/O table" from the Edit I/O Table menu. Press the End Key or Ctrl+M Keys to display the file names, select the required file name with the cursor, and press the Enter Key.
The file name will be displayed.
 3. Press the Enter Key to retrieve the I/O table data. The I/O table editing screen will be displayed after the data has been retrieved.

4-5-5 Clearing I/O Tables

- 1, 2, 3...
1. Select "C:Clear I/O table" from the Edit I/O Table menu.
 2. Press the Y and Enter Keys to clear the I/O table data from the work disk.
or Press the Enter Key to cancel and return to the menu.

4-5-6 Customizing I/O Tables

"Z:Custom I/O table SIOU" is not used at present.

4-5-7 PC Setup

This operation is used to set the parameters in the PC Setup that are related to the I/O table. These parameters include the first word allocated on the Basic Racks, on the Slave Racks, to group-1 Slaves, to group-2 Slaves, and to I/O Terminals.

During offline operation, the PC Setup is changed on the work disk only. The data in the PC itself is not changed.

- 1, 2, 3...
1. Select the "A:PC setup" from the main menu.

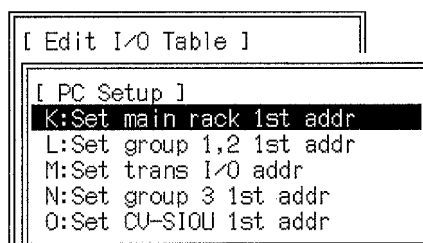

2. Select the items to be changed from the sub-menu.

See *7-2 PC Setup* for the procedure to change parameters in the PC.

To change the PC Setup in the PC, transfer them from the CVSS to the PC or change them directly in the PC. Both of these operations are available only in online operations. Refer to the *CV Support Software Version 2: Online* for details.

4-6 Editing Network Support Tables

The following operations are used to create data link tables and to create routing tables for SYSMAC NET and SYSMAC LINK. It is necessary to set data link tables only when they have been set for manual setting (specific) in online operations. Routing tables are required for communication between networks. Separate data link tables are set for SYSMAC NET and SYSMAC LINK System, but the same routing tables are used by both Systems.

Network support tables are created in the main memory and not written to the work disk. Therefore, you must immediately save data created for the network support tables to a data disk or the hard disk. The network support tables will be lost if it has not be saved when the reset switch is pressed, the POWER switch turned off, or the main offline menu selected.

To access the Network Support Table main menu select "N:Network support table" from the main offline menu. The desired operation can then be selected.

```
[ Network Support Table ]
N:Data link table (SYSMAC NET)
L:Data link table (SYSMAC LINK)
R:Routing table
```

4-6-1 SYSMAC NET Data Link Tables

The following display will appear when "N:Data link table (SYSMAC NET)" is selected from the Network Support Table main menu.

#	Node addr	I/O		DM		#	Node addr	I/O		DM		#
		Beg	Wd	Beg	Wd			Beg	Wd	Beg	Wd	
1	001	0000		1	D00000	1	17					
2	002	0001		1	D00001	1	18					
3							19					
4							20					
5							21					
6							22					
7							23					
8							24					
9							25					
10							26					
11							27					
12							28					
13							29					
14							30					
15							31					
16							32					

- 1, 2, 3... 1. Press the End Key or Ctrl+M Keys to display the SYSMAC NET menu.

```
[ SYSMAC NET ]
E>Edit data link table
K:Check data link table
C:Clear data link table
S:Save data link table
L:Retrieve data link table
P:Print data link table
```

2. Select the required operation.

Operation	Function
Check data link table	Checks the data link table in memory and displays any error found.
Clear data link table	Clears all data link table data from the main memory.
Edit data link table	Used to create and edit data link tables.
Print data link table	Prints the data link table data in the main memory.
Retrieve data link table	Retrieves the data link table data from the data disk or hard disk to the main memory.
Save data link table	Saves the data link table data in the main memory to the data disk or hard disk.

Editing Data Link Tables

Select "E:Edit data link table" from the SYSMAC NET menu.

A message at the top-right of the screen will indicate that the data link table is being edited.

- 1, 2, 3...**
1. Follow the sequence below to set the number of nodes in the range from 2 to 32:
 F1 Key, *number_of_link_nodes*, Enter Key
 2. Move the cursor to the position where data is to be input and enter the data. Input the node address, I/O start word, number of I/O words, DM start word, and number of DM words.
 3. When all data is input, press the F10 Key to save the data.

Node address	Make sure that the same address is not input twice. The node address is set on the SYSMAC NET Link Unit. Press the Insert Key to insert a node address or the Delete Key to delete a node address. Set the node address in the range 1 to 126.
Start I/O and DM words, number of words	Set the I/O and DM start words for the first node only. The I/O and DM start words for the subsequent nodes are automatically set after the data is created. Input Enter, <i>word_address</i> , Enter to input the start word. Set the number of I/O and DM words in the range 1 to 127. Set the I/O start and the number of words so that the last word does not exceed CIO 2555. Set the DM start and number of words so that the last word does not exceed D8191 for the CV500 or D24575 for the DV1000. Restrict the total number of I/O and DM words to below 3,584 words.

Checking Data Link Tables

The following operation is used to check manually input data link tables.

- 1, 2, 3...**
1. Select "K:Check data link table" from the SYSMAC NET menu.
 A message will indicate if no errors were detected.
 An error message table will be displayed if errors are found.
 2. If *continue* is displayed at the bottom of the screen, press the PgDn Key to display the next page of error messages. If errors are detected, correct the data link table and run the check again.

< >
Chk data link tbl SYSMAC NET

#	Node	Error message	#	Node	Error message
1	001	Dup node address			
2	001	Dup node address			
3	007	Dup node address			
4	007	Dup node address			
3	007	I/O exceeded			
4	007	I/O exceeded			

Last page

Error Message Table

Error message	Error description	Remedy
DM Begin Wd err	The DM start word address lies out of range.	Set the DM start word address within the prescribed range.
DM exceeded	The DM link area lies out of range.	Set the DM link area so that the limit is not exceeded by reducing the number of DM words or lowering the DM first word.
Dup node address	Duplicate node addresses set.	Do not set the same node address twice.
I/O Begin Wd err	The I/O start word address exceeds CIO 2555.	Set the I/O start word address to CIO 2555 or below.
I/O exceeded	The data link area exceeds CIO 2555.	Set the I/O link area to CIO 2555 or below by reducing the number of I/O words or lowering the I/O first word.
Link node range err	The number of link nodes lies outside the range 2 to 32.	Change settings to bring the number of link nodes inside the range 2 to 32.
Node range err	A node address is set outside the range 1 to 126.	Set the node address within the range 1 to 126.
Too many DM link Wd	Number of DM words lies outside the range 1 to 127.	Change the settings to bring the number of DM words within the range 1 to 127.
Too many I/O link Wd	Number of I/O words lies outside the range 1 to 127.	Change the settings to bring the number of I/O words within the range 1 to 127.
Too many words	The total number of I/O and DM words for all nodes exceeds 3,584.	Reduce the total number of I/O and DM words to below 3,584.

Clearing Data Link Tables

- 1, 2, 3...**
1. Select "C:Clear data link table" from the SYSMAC NET menu.
 2. Press the Y and Enter Keys to clear the contents of the data link table.
or Press the Enter Key to cancel and return to the menu.

Saving Data Link Tables

Be sure the data disk has been formatted and is not write-protected. Data link table data cannot be saved if it exceeds the free space available on the data disk.

- 1, 2, 3...**
1. Select "S:Save data link table" from the SYSMAC NET menu. A file name input area will be displayed.
 2. Enter the file name and press the Enter Key.
To enter an existing file name, press the End Key or Ctrl+M Keys to display the current file names, select the required file name with the cursor, and press the Enter Key.
 3. If the input file name already exists, a message will ask if the file should be overwritten. Press the Y and Enter Keys to overwrite the file. Press the Enter Key to cancel and input a new file name.
The title input area will appear when the Enter Key is pressed.
 4. Input the title and press the Enter Key.
The title can be up to 30 characters long.
A message will flash while the table is being saved. The data link table will be displayed after the data is saved.

Note Enter the file name as up to 8 characters. Lower-case characters are converted to upper-case. A single directory name can have up to 8 characters with a total of 66 characters for the entire path name. See *6-2 File Management* for more information about directories.

Retrieving Data Link Tables

- 1, 2, 3...**
1. Select "L:Retrieve data link table" from the SYSMAC NET menu.

A file name input area will be displayed.

2. Enter the file name and press the Enter Key. Press the End Key or Ctrl+M Keys to display the file names, select the required file name with the cursor, and press the Enter Key to input the file name.
3. Press the Enter Key to retrieve the data link table.

A message will flash while the table is being retrieved. The data link table will be displayed after the data is retrieved.

Printing Data Link Tables

- 1, 2, 3... 1. Select "P:Print data link table" from the SYSMAC NET menu. Printing will be started.
The *Printing* message will disappear when printing is complete.
2. Press the Esc Key to cancel printing. All characters in the print buffer will be printed before printing stops.

Sample Print-out

< < < SYSMAC NET Data Link Table Directory > > >

27/12/91 PAGE = 0001

[CV-series PC]

Node			I/O		DM		Node			I/O		DM			
#	addr	Beg	Wd	Wds	Beg	Wd	Wds	#	addr	Beg	Wd	Wds	Beg	Wd	Wds
1	001	0000		1	D00000		1	17							
2	002	0001		1	D00001		1	18							
3								19							
4								20							
5								21							
6								22							
7								23							
8								24							
9								25							
10								26							
11								27							
12								28							
13								29							
14								30							
15								31							
16								32							

4-6-2 SYSMAC LINK Data Link Tables

The following display will appear when "L:Data link table (SYSMAC LINK)" is selected from the Network Support Table main menu.

Common Link Parameter Screen

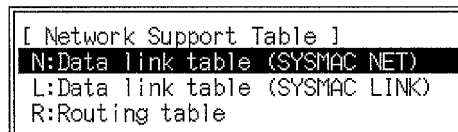

Press the PgDn and PgUp Keys to display the parameter screens for nodes 1 to 62. The required refresh parameter screen can also be displayed by pressing the F1, *node address*, Enter Keys.

Node Refresh Parameter Screen

Disp dat link tbl SYSMAC LINK

Node[01] PC[CU-ser] refreshWd[0000] [D00000] status Wd[D00200]

#	Node	I/O	DM	#	Node	I/O	DM	#	Node	I/O	DM	#	Node	I/O	DM
1	01	1	1	17				33				49			
2	02	1	1	18				34				50			
3				19				35				51			
4				20				36				52			
5				21				37				53			
6				22				38				54			
7				23				39				55			
8				24				40				56			
9				25				41				57			
10				26				42				58			
11				27				43				59			
12				28				44				60			
13				29				45				61			
14				30				46				62			
15				31				47							
16				32				48							

Node[01] refreshWd[0000] [D00000]

1 node 2 count 3 4 5 6 7 8 9 0

Press the F2 Key to revert to the common link parameter screen.

SYSMAC LINK Menu

Press the End Key or Ctrl+M Keys from the data link table screen to display the SYSMAC LINK menu and select the required operation.

[SYSMAC LINK]
E>Edit data link table
K:Check data link table
Y:Copy data link table
C:Clear data link table
S:Save data link table
L:Retrive data link table
P:Print data link table

Operation	Function
Check data link table	Checks the data link table in memory and displays any errors found.
Clear data link table	Clears all data link data from the main memory.
Copy data link table	Copies refresh data parameters from a specified node to multiple nodes.
Edit data link table	Used to create and edit data link tables.
Print data link table	Prints the data link table data in the main memory.
Retrieve data link table	Retrieves the data link table data from the data disk or hard disk to the main memory.
Save data link table	Saves the data link table data in the main memory to the data disk or hard disk.

Function Keys

Function key	Range				Function
	Display		Edit		
	Common	Refresh	Common	Refresh	
F1	Yes	Yes	Yes	Yes	Used to input a node address and display the refresh parameter screen for a specified node. Press the F1, <i>node_address</i> , and Enter Keys.
F2	---	Yes	---	Yes	Returns to the common link parameter screen from a refresh parameter screen.
F8	---	---	---	Yes	Enables a refresh parameter previously disabled with the F9 Key. Initially, only node addresses 1 and 2 are enabled; all others are disabled. To enable other nodes to be used, press the F8, number of refresh nodes, and Enter Keys from each node screen. A data link table is only displayed for enabled nodes.
F9	---	---	---	Yes	Disables the node currently displayed, while leaving the data in the refresh parameter screen unchanged. Press the F9 Key once to disable each node. Press the Enter Key in response to the confirmation message.
F10	---	---	Yes	Yes	Press the F10 Key after creating data on the screen to save the data and return to the SYSMAC LINK menu. The F10 can also be used to save each screen of data as it is created.

Editing Data Link Tables

Select "K:Edit data link table" from the SYSMAC LINK menu. The common data link table will appear and a message at the top-right of the screen will indicate that the data link table is being edited.

Edit dat link tbl SYSMAC LINK

Com cyc time[---ms]

Node	I/O #	DM #	Node	I/O #	DM #	Node	I/O #	DM #	Node	I/O #	DM #
01	1	1	17	-	-	33	-	-	49	-	-
02	1	1	18	-	-	34	-	-	50	-	-
03	-	-	19	-	-	35	-	-	51	-	-
04	-	-	20	-	-	36	-	-	52	-	-
05	-	-	21	-	-	37	-	-	53	-	-
06	-	-	22	-	-	38	-	-	54	-	-
07	-	-	23	-	-	39	-	-	55	-	-
08	-	-	24	-	-	40	-	-	56	-	-
09	-	-	25	-	-	41	-	-	57	-	-
10	-	-	26	-	-	42	-	-	58	-	-
11	-	-	27	-	-	43	-	-	59	-	-
12	-	-	28	-	-	44	-	-	60	-	-
13	-	-	29	-	-	45	-	-	61	-	-
14	-	-	30	-	-	46	-	-	62	-	-
15	-	-	31	-	-	47	-	-			
16	-	-	32	-	-	48	-	-			

1 node 2 comm 3 4 5 6 7 8 9 0 end

Input the communications cycle time, and input the number of I/O and DM words for the data link to each node. Use the Up, Down, Left, Right Keys to move the cursor to the required position on the screen.

Parameter	Setting method
Com cyc time	<p>This is the time taken for the token to pass all the nodes in the data link. Initially dashes (-) will be displayed to indicate that the cycle times is set automatically. This is the normal setting. Press the Home Key twice to return the communications cycle time to automatic calculation.</p> <p>Set the cycle time to a constant value if the cycle time fluctuates due to noise or other causes. To set a value for the transfer cycle time, input the value in the range 5 to 255 ms and press the Enter Key. Set the time to a value somewhat above the maximum communications cycle time. The data link may malfunction if the cycle time setting is too short.</p>
I/O and DM #	<p>Set the number of I/O (CIO Area) and DM word used in the data link. Initially dashes (-) are displayed to indicate that there are no I/O or DM words in the data link. If the numbers of words is set to zero for a node, that node will not transmit data into the data link but can access data transmitted by other node and data link status will be refreshed.</p> <p>Press the dash (-) Key to revert a set value back to the initial dash (-).</p> <p>Set the numbers of I/O and DM words in the ranges specified below:</p> <p>Only CV-series PCs in data link: I/O words 0 to 254 DM words 0 to 254</p> <p>Other PCs in data link: I/O words 0 to 64 DM words 0 to 254</p> <p>Restrict the total number of I/O and DM words to below 2,966 words.</p>

Editing Refresh Parameters

Use one of the following methods to display a refresh parameter screen:

Press the PgDn and PgUp Keys to scroll through the screens
 Press the F1, node address, Enter Keys.

< > [edit dat link tbl] SYSMAC LINK

Node[01] PC[CU-ser] refreshWd[0000] [D0000] status Wd[D00200]

#	Node	I/O	DM	#	Node	I/O	DM	#	Node	I/O	DM	#	Node	I/O	DM
1	01	1	1	17				33				49			
2	02	1	1	18				34				50			
3				19				35				51			
4				20				36				52			
5				21				37				53			
6				22				38				54			
7				23				39				55			
8				24				40				56			
9				25				41				57			
10				26				42				58			
11				27				43				59			
12				28				44				60			
13				29				45				61			
14				30				46				62			
15				31				47							
16				32				48							

1: node 2: comm 3: 4: 5: 6: 7: 8: enab 9: disa 0: end

The data link table cannot be displayed for a disabled node. To use a node, press the F8, node_address, and Enter Keys to enable the node before displaying the data link table. If the F9 Key is pressed after a data link table has been created, the contents of the table will remain unchanged but the data link will be disabled.

Set the items shown in the following table for each enabled node. Use the Up, Down, Left, Right Keys to move the cursor to the required position on the screen.

Item	Setting method
PC	Set the PC series of the node. Press the 1 Key for CV-series PC and the 2 Key for other PC and then press the Enter Key.
Refresh wd	Set the first data link word for the displayed node in the CIO (IR) or DM Area. Input the Enter Key, <i>word_address</i> , Enter Key.
Status wd	This setting is not required for CV-series PCs. The word is allocated CIO 1500. For C-series PCs, set the first word of the data link status area. Input the Enter Key, <i>word_address</i> , Enter Key.
Node	The node displayed at the top is the node for which the data link is being set. Be sure you are setting data for the correct node. Only set nodes previously set in the common link parameters. Words set for the current node (i.e., the node displayed at the top) are written by the current node and are transferred to the other nodes. Words set for other nodes are written by the other nodes and received by the current node. I/O words and DM words set in the common link parameters will be automatically displayed. The data link area will be allocated from the first refresh words set in the table in order of the numbers at the left of the table. Press the Insert Key to insert a node or the Delete Key to delete a node.

Parameter Ranges

Parameter	PC		
	CV500-CPU01-E CVM1-CPU01-E	CV1000-CPU01-E CV2000-CPU01-E CVM1-CPU11-E	Other
I/O (CIO) link words	0 to 254		0 to 64
DM link words	0 to 254		0 to 254
I/O (CIO) start word and end word (start word plus number of words)	0000 to 2555		1000 to 1063
DM start word and end word (start word plus number of words)	D00000 to D08191	D00000 to D24575	D00000 to D04095
Status start word and end word (start word plus number of words)	---		0000 to 0252 1000 to 1191 D00000 to D04095

Checking Data Link Tables The following operation is used to check manually created data link tables.

- 1, 2, 3...** 1. Select "K:Check data link table" from the SYSMAC LINK menu to start the check.

A message will indicate if no errors were detected.

An error message table will be displayed if errors are found.

- If *continue* is displayed at the bottom of the screen, press the PgDn Key to display the next page of error messages. If errors are detected, correct the data link table and run the check again.

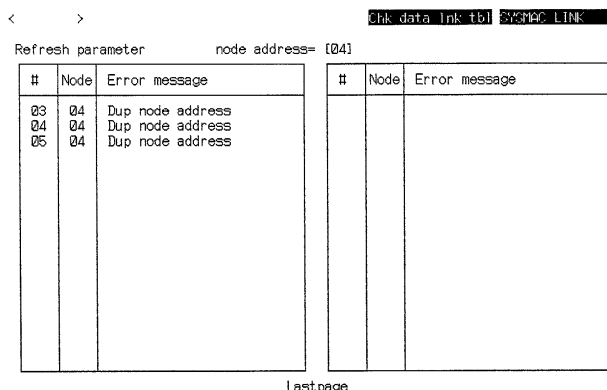

Error Message Table

Common Link Parameter Error Messages

Error message	Error description	Remedy
Comm cycle time range err	The transfer cycle time is not set to automatic or 5 to 255.	Press the Home Key to set automatic calculation or set a value in the range 5 to 255.
Too many DM words	The number of DM words exceeds 254.	Set the number of DM words to below 254.
Too many I/O words	The number of I/O words exceeds the prescribed range.	Change settings to bring the number of words inside the prescribed range.
Too many words	The total number of I/O and DM words exceeds the prescribed range.	Change settings to bring the total number of I/O and DM words to below 2,966 words.

Refresh Parameter Error Messages

Error message	Error description	Remedy
Begin I/O Wd range err	The first I/O word lies outside the prescribed range.	Change settings to bring the first I/O word inside the prescribed range.
Begin I/O Wd set err	The data link exceeds the permissible area range.	Lower the first I/O word to bring the entire link area within the prescribed range.
Begin DM Wd range err	The first DM word lies outside the prescribed range.	Change settings to bring the first DM word inside the prescribed range.
Begin DM Wd set err	The data link exceeds the permissible link area range.	Lower the first DM word to bring the entire link area within the prescribed range.
Begin status Wd range err	The first status word lies outside the prescribed range.	Change settings to bring the first status word inside the prescribed range.
Begin status Wd set err	The status area is too small.	Lower the status start word to bring the entire status area within the prescribed range.
Dup node address	A node address is duplicated.	Do not set the same node address twice.
Node addr range err	The node address is set outside the range 1 to 62.	Set the node address in the range 1 to 62.
Node addr set err	The set node address is not set in the common link parameters.	Only set nodes previously set in the common link parameters.
No send area	Link area does not exist for the node.	Set the data link words for the current node.
Refresh node range err	Number of refresh nodes lies outside the range 2 to 62.	Check the contents of the data link table.

Copying Data Link Tables

- 1, 2, 3... 1. Select "Y:Copy data link table" from the SYSMAC LINK menu.

2. Enter the copy source node address in the range 1 to 62 and press the Enter Key. Nodes that are disabled cannot be set.
3. Press the Enter Key to display the screen to set the copy destination.

```
[ SYSMAC LINK ]
E:Edit data link table
K:Check data link table
Y:Copy data link table
C:Clear data link table
S:Save data link table
L:Retrive data link table
P:Print data link table
```

4. Move the cursor to the copy destination nodes and press the Enter Key. Yes will be displayed to indicate nodes that have been set as a copy destinations. Multiple nodes can be set.
To deselect a node as a copy destination, move the cursor to the node and press the Enter Key again.
5. Select "J :Run."
The copy source node will be copied to the destination nodes, and all previous data will be cleared from the copy destination nodes.
Disabled copy destination nodes will be enabled after the copy is complete.
The common link parameter screen will be displayed when the copy is complete.

Clearing Data Link Tables

1, 2, 3...

1. Select "C:Clear data link table" from the SYSMAC LINK menu.
2. Press the Y and Enter Keys to clear the contents of the data link table and enable only nodes 1 and 2 enabled (all others nodes will be disabled).

Saving Data Link Tables

Be sure the data disk has been formatted and is not write-protected. Data link table data cannot be saved if it exceeds the free space available on the data disk.

1, 2, 3...

1. Select "S:Save data link table" from the SYSMAC LINK menu. A file name input area will be displayed.
2. Enter the file name and press the Enter Key.
To enter an existing file name, press the End Key or Ctrl+M Keys to display the current file names, select the required file name with the cursor, and press the Enter Key.
3. If the input file name already exists, a message will ask if the file should be overwritten. Press the Y and Enter Keys to overwrite the file. Press the Enter Key to cancel and input a new file name.
The title input area will appear when the Enter Key is pressed.
4. Input the title and press the Enter Key. The title can be up to 30 characters long.
A message will flash while the table is being saved. The data link table will be displayed after the data is saved.

Note Enter the file name as up to 8 characters. Lower-case characters are converted to upper-case. A single directory name can have up to 8 characters with a total of 66 characters for the entire path name. See 6-2 *File Management* for more information about directories.

Retrieving Data Link Tables

1, 2, 3...

1. Select "L:Retrieve data link table" from the SYSMAC LINK menu. A file name input area will be displayed.

2. Enter the file name and press the Enter Key. Press the End Key or Ctrl+M Keys to display the file names, select the required file name with the cursor, and press the Enter Key to input the file name.
3. Press the Enter Key to retrieve the data link table.
A message will flash while the table is being retrieved. The data link table will be displayed after the data is retrieved.

Printing Data Link Tables

- 1, 2, 3... 1. Select "P:Print data link table" from the SYSMAC LINK menu. Printing will be started.
The *Printing* message will disappear when printing is complete.
2. Press the Esc Key to cancel printing. All characters in the print buffer will be printed before printing stops.

Sample Print-out

< < < SYSMAC LINK Data Link Table Directory > > >

27/12/91 PAGE = 0001

[Common Parameters]

Comm cycle time = [--- ms]

Node	I/O	DM	Node	I/O	DM	Node	I/O	DM	Node	I/O	DM
01	1	2	17	-	-	33	-	-	49	-	-
02	2	3	18	-	-	34	-	-	50	-	-
03	5	0	19	-	-	35	-	-	51	-	-
04	-	-	20	-	-	36	-	-	52	-	-
05	-	-	21	-	-	37	-	-	53	-	-
06	-	-	22	-	-	38	-	-	54	-	-
07	-	-	23	-	-	39	-	-	55	-	-
08	10	0	24	-	-	40	-	-	56	-	-
09	-	-	25	-	-	41	-	-	57	-	-
10	-	-	26	-	-	42	-	-	58	-	-
11	-	-	27	-	-	43	-	-	59	-	-
12	5	0	28	-	-	44	-	-	60	-	-
13	-	-	29	-	-	45	-	-	61	-	-
14	-	-	30	-	-	46	-	-	62	-	-
15	-	-	31	-	-	47	-	-			
16	-	-	32	-	-	48	-	-			

4-6-3 Routing Tables

To set the routing tables, select "R:Routing table" from the Network Support Table main menu. The local network table will be displayed.

Local Network Table

[Local Network Table]

#	Loc Netwk	SIQU unit #	#	Loc Netwk	SIQU unit #
1	001	00	9		
2			10		
3			11		
4			12		
5			13		
6			14		
7			15		
8			16		

Press the PgDn and PgUp Keys to scroll between the local network table and the relay network table.

Relay Network Table

[Relay Network Table]

#	End Netwk	PC ID	Relay Netwk	node
1	002		001	001
2				
3				
4				
5				
6				
7				
8				
9				
10				

#	End Netwk	PC ID	Relay Netwk	node
11				
12				
13				
14				
15				
16				
17				
18				
19				
20				

Routing Table Menu

Press the End Key or Ctrl+M Keys from the routing table screen to display the Routing Table menu, and select the required operation.

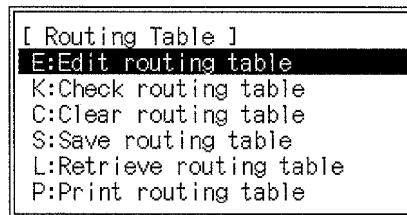

Operation	Function
Check routing table	Checks the routing table in main memory and displays any errors found.
Clear routing table	Clears all routing table data from the main memory.
Edit routing table	Used to create and edit routing tables.
Print routing table	Prints the routing table data in the main memory.
Retrieve routing table	Retrieves the routing table data from the data disk or hard disk to the main memory.
Save routing table	Saves the routing table data in the main memory to the data disk or hard disk.

Network Communication Range

The CVSS offers SYSMAC NET and SYSMAC LINK network communication for transfer of user data and for monitor between the PCs and computers on the network. Communications is possible to up to two network levels away (3, including the local network level). An example is shown below.

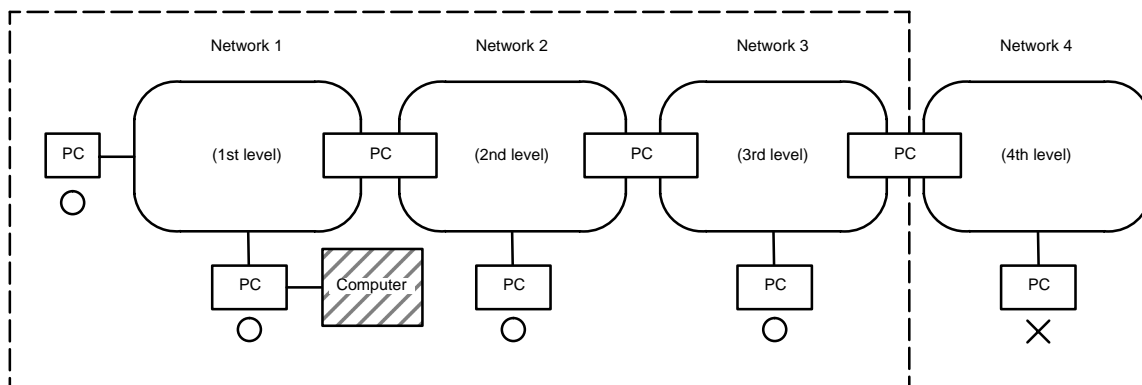

Communication range of shaded computer.

In the example shown above, the computer connected to the PC in network 1 can communicate with PCs on networks 2 or 3. It cannot communicate with the PCs on network 4, which is the 4th level of communications.

Communication with a C-series PCs

The CV pack is intended for operation of CV Series PC's only. Therefore, C Series PC's cannot be operated via the networks, except for the I/O monitor operations which can be used with C Series PC's on the SYSMAC LINK network.

CV Series PC's cannot operate a PC through the network if the SYSMAC LINK unit for the PC is set to C mode.

Editing Routing Tables

To edit the routing tables, select "E:Edit routing table" from the Routing Table menu. The local network table will appear (see below) and a message at the top-right of the screen will indicate that the routing table is being edited.

The following function keys can be used during editing operations.

Function key	Function
F1 (Net #)	Sets or changes the number of networks when editing the local networks or relay networks. Input the F1 Key, <i>number_of_networks</i> , and Enter Key. The number of networks can be set to a maximum of 16 local networks or 20 relay networks.
F10 (end)	Press the F10 Key after creating data on the screen to save the data and return to the Routing Table Menu. Always press the F10 Key to save the routing table after creating data.

Editing Local Network Tables

[Local Network Table]

#	Loc Netwk	SIOU unit #	#	Loc Netwk	SIOU unit #
1	001	00	9		
2			10		
3			11		
4			12		
5			13		
6			14		
7			15		
8			16		

Set the items shown in the following table. Use the Up, Down, Left, Right Keys to move the cursor to the required positions on the screen.

Item	Setting method
Loc Netwk	Set the network address of each CPU Bus Unit mounted to the PC. Set the network addresses in the range 1 to 127. Make sure that the same network address is not input twice. Press the Insert Key to insert a network address or the Delete Key to delete a network address.
SIOU unit #	Set the unit number of each CPU Bus Unit mounted to the PC. Set the unit numbers in the range 0 to 15. Make sure that the same unit number is not set twice.

Press the PgDn Key to display the relay network table editing screen (see next diagram).

Editing Relay Network Tables

[Relay Network Table]

#	End Netwk	Relay			#	End Netwk	Relay		
		PC ID	Netwk	node			PC ID	Netwk	node
1	002		001	001	11				
2					12				
3					13				
4					14				
5					15				
6					16				
7					17				
8					18				
9					19				
10					20				

Set the items shown in the following table. Use the Up, Down, Left, Right Keys to move the cursor to the required positions on the screen.

Item	Setting method
End Netwk	Set each end network address for network relay communication. Set the network addresses in the range 1 to 127. Do not set the same address twice. Press the Insert Key to insert a network address or the Delete Key to delete a network address.
Relay network, node	Set the network and node addresses of the first node that must be passed through to reach the destination network. Set the network addresses in the range 1 to 127. Only set networks that are in the local network table. The network and node addresses can also be set using PC ID. Move the cursor to the PC ID column and input the Enter Key, <i>PC_name</i> , and Enter Key. Press the End Key or Ctrl+M Keys to display PC IDs. Select the required PC ID from the table with the cursor and press the Enter Key. The network address and node address will automatically be displayed when the PC ID is input.

Press the PgUp Key to return to the local network table editing screen.

Checking Routing Tables

The following operation is used to check routing tables.

- 1, 2, 3... 1. Select "K:Check routing table" from the Routing Table menu.

A message will indicate if no errors were detected. An error message table will be displayed if errors are found.
2. If *continue* is displayed at the bottom of the screen, press the PgDn Key to display the next page of error messages.

If errors are detected, correct the routing table and run the check again.

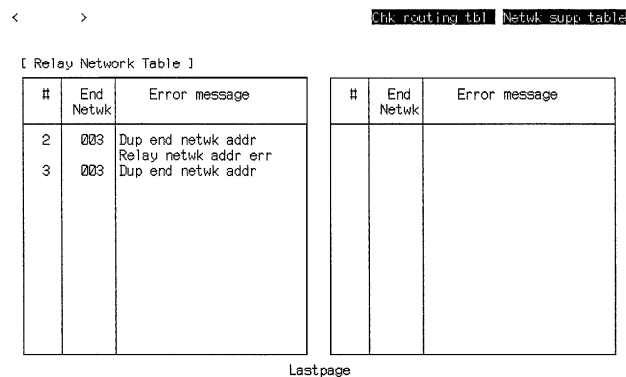

Error Message Table

Local Network Error Messages

Error message	Error description	Remedy
Dup local netwk addr	Duplicate network addresses set.	Do not set the same network address twice.
Dup SIOU unit # err	Duplicate unit numbers CPU Bus Units.	Do not set the same unit number for two CPU Bus Units.
Local netwk addr err	A network address is set outside the range 1 to 127.	Set the network address within the range 1 to 127.
SIOU unit # range err	Unit number of a CPU Bus Unit is set outside the range 0 to 15.	Set the unit number within the range 0 to 15.
Too many networks	More than 16 networks are set.	Set no more than 16 networks.

Relay Network Error Messages

Error message	Error description	Remedy
Dup end netwk addr	Duplicate network addresses set.	Do not set the same network address twice.
End netwk addr range err	A network address is set outside the range 1 to 127.	Set the network address within the range 1 to 127.
Relay netwk addr err	The set network address is not set in the local network table.	Only set network addresses already set in the local network table.
Relay netwk addr rng err	A network address is set outside the range 1 to 127.	Set the network address within the range 1 to 127.
Relay node addr rng err	A node address is set outside the range 1 to 126.	Set the node address within the range 1 to 126.
Too many networks	More than 20 networks are set.	Set no more than 20 networks.

Clearing Routing Tables

- 1, 2, 3...**
1. Select "C:Clear routing table" from the Routing Table menu.
 2. Press the Y and Enter Keys to clear the contents of the routing table.
- or Press the Enter Key to cancel and return to the menu.

Saving Routing Tables

Be sure the data disk has been formatted and is not write-protected. Routing table data cannot be saved if it exceeds the free space available on the data disk.

- 1, 2, 3...**
1. Select "S:Save routing table" from the Routing Table menu.
A file name input area will be displayed.
 2. Enter the file name and press the Enter Key.
To enter an existing file name, press the End Key or Ctrl+M Keys to display the current file names, select the required file name with the cursor, and press the Enter Key.

3. If the input file name already exists, a message will ask if the file should be overwritten. Press the Y and Enter Keys to overwrite the file. Press the Enter Key to cancel and input a new file name.

The title input area will appear when the Enter Key is pressed.

4. Input the title and press the Enter Key. The title can be up to 30 characters long.

A message will flash while the table is being saved. The routing table will be displayed after the data is saved.

Note Enter the file name as up to 8 characters. Lower-case characters are converted to upper-case. A single directory name can have up to 8 characters with a total of 66 characters for the entire path name. See 6-2 *File Management* for more information about directories.

Retrieving Routing Tables

- 1, 2, 3... 1. Select "L:Retrieve routing table" from the Routing Table menu. A file name input area will be displayed.
2. Enter the file name and press the Enter Key.
Press the End Key or Ctrl+M Keys to display the file names. Select the required file name with the cursor and press the Enter Key to input the file name.
3. Press the Enter Key to retrieve the routing table.
A message will flash while the table is being retrieved. The routing table will be displayed after the data is retrieved.

Printing Routing Tables

Before printing, connect the printer and turn power on so that the printer is ready to print.

- 1, 2, 3... 1. Select "P:Print routing table" from the Routing Table menu. Printing will be started.
The *Printing* message will disappear when printing is complete.
2. Press the Esc Key to cancel printing. All characters in the print buffer will be printed before printing stops.

Sample Print-out

< < <

Routing Table Directory

> > >

27/12/91

PAGE = 0001

[Local Network Table]

#	Loc Netwk	SIOU unit #	#	Loc Netwk	SIOU unit #
1	001	00	9		
2	002	01	10		
3			11		
4			12		
5			13		
6			14		
7			15		
8			16		

[Relay Network Table]

#	End Netwk	Relay		Netwk	Node	Netwk	PC ID	Netwk	Node
		PC ID	Netwk						
1	002		001	001	11				
2					12				
3					13				
4					14				
5					15				
6					16				
7					17				
8					18				
9					19				
10					20				

4-7 Editing PC IDs

A PC ID is a name assigned to each node of a SYSMAC NET or SYSMAC LINK network. For example, the name RED could be assigned to node 2 on network 1. Once set, the assigned name can be specified instead of the network and node addresses.

The example below shows an example of PC IDs in SYSMAC NET networks.

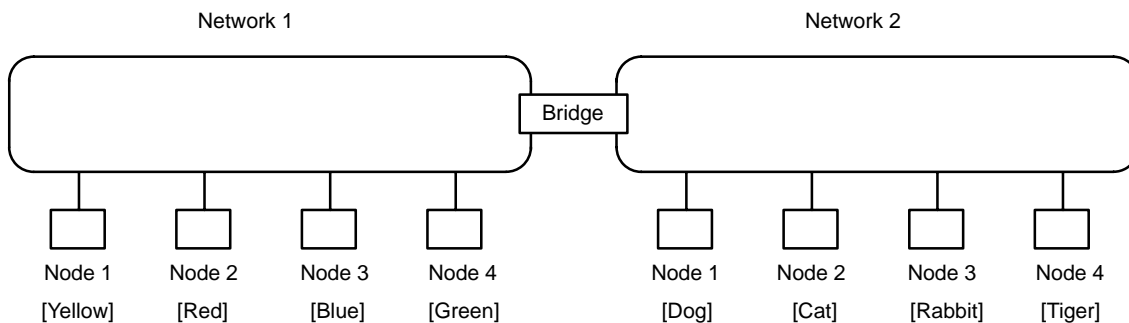

The PC IDs for the networks in the diagram are listed in the following table.

Row	Network	Node	PC ID
001	001	001	YELLOW
002	001	002	RED
003	001	003	BLUE
004	001	004	GREEN
005	002	001	DOG
006	002	002	CAT
007	002	003	RABBIT
008	002	004	TIGER

The PC ID editing operations handle the PC IDs in the format shown in the table. A maximum of 500 PC IDs can be registered with up to 8 characters per name. The input is case-sensitive: upper-case and lower-case letters are treated as different. More than one PC ID cannot be assigned to a single node and the same PC ID cannot be assigned to more than one node.

To display the PC ID editing screen, select "W:Edit PC ID" from the main offline menu.

Read Edit PC ID
PAGE 001/001

R	Netwk	Node	PC ID	R	Netwk	Node	PC ID
001				018			
002				019			
003				020			
004				021			
005				022			
006				023			
007				024			
008				025			
009				026			
010				027			
011				028			
012				029			
013				030			
014				031			
015				032			
016				033			
017				034			

write 2 read 3 chge 4 page 5 R # 6

Function Key Operations

Function key	Name	Function
F1	write	Switches to write mode.
F2	read	Switches to read mode. Displays the first page if pressed in the read or change mode.
F3	chge	Switches to change mode.
F4	page	Displays a specified page. Only enabled in the read and change modes. Input the F4 Key, <i>page_number</i> , and the Enter Key.
F5	R #	Displays a specified row. Only enabled in the read and change modes. Input the F5 Key, <i>row_number</i> , and the Enter Key.

Moving the Cursor

Key	Function
Up	Moves the cursor up one row. The cursor will jump from the top row to the bottom row.
Down	Moves the cursor down one row. The cursor will jump from the bottom row to the top row.
Left	Moves the cursor left.
Right	Moves the cursor right.

4-7-1 Writing PC IDs

To write new PC IDs, press the F1 Key from the PC Name screen to switch to the write mode. A message in the top-left of the screen will indicate that the write mode is selected, the cursor will move to the first blank row, and a PC ID input area will be displayed at the bottom of the screen. In the write mode, data can be written only to blank rows. Switch to the change mode to edit existing data.

Write Edit PC ID
PAGE 001/001

R	Netwk	Node	PC ID	R	Netwk	Node	PC ID
001				018			
002				019			
003				020			
004				021			
005				022			
006				023			
007				024			
008				025			
009				026			
010				027			
011				028			
012				029			
013				030			
014				031			
015				032			
016				033			
017				034			

Netwk [000] Node [] PC ID []
1 2 read 3 chae 4 5 6 7 8 9

- 1, 2, 3...**
1. Enter the network address in the range 0 to 127 and press the Enter Key.
 2. Enter the node address in the range 0 to 126 and press the Enter Key.
The node address can be set to 0 only if the network address is also set to 0.
 3. Enter the PC ID and press the Enter Key.
The entered data will appear in the blank row at the cursor and the cursor will move down to the next row.
Up to 500 rows of data can be entered. The read mode is selected automatically after the 500th row of data is entered.
The cursor cannot be moved around the screen when the write mode is selected.
 4. Press the Esc Key to move the insertion point from one input area at the bottom of the screen to the previous input area.
 5. Press the F2 Key or Shift+Esc Keys to return to the read mode.

4-7-2 Changing PC IDs

- 1, 2, 3...**
1. In the read mode, press the F3 Key to switch to the change mode.
A message in the top-left of the screen will indicate that the change mode is selected.
 2. Move the cursor to the PC ID to be changed and press the Enter Key. The PC ID can now be re-input as described above. The PC ID will changed when new data is input.
 3. Press the Shift+Esc Keys to return to the first page.

4-7-3 Edit PC ID Menu

- 1, 2, 3... 1. Press the End Key or Ctrl+M Keys in the read mode to display the main menu.

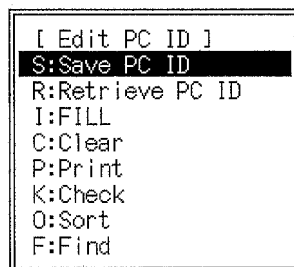

2. Select the required operation.
or Press the Esc Key or Shift+Esc Keys to return to the read mode.

Operation	Function
Check	Checks the edited PC ID and displays any errors found.
Clear	Clears data from all rows in a specified range.
FILL	Writes the same specified network address, node address, or PC ID data to consecutive rows.
Find	Finds a specified item in PC ID data.
Print	Prints the PC ID data.
Retrieve PC ID	Retrieves the PC ID data from the data disk or hard disk to the work disk.
Save PC ID	Saves the PC ID data in the work disk to the data disk or hard disk.
Sort	Sorts PC IDs in numerical and alphabetical order.

4-7-4 Saving PC IDs

Be sure the data disk has been formatted and is not write-protected. PC ID data cannot be saved if it exceeds the free space available on the data disk.

- 1, 2, 3... 1. Select "S:Save PC ID" from the Edit PC ID menu. A file name input area will be displayed.
2. Enter the file name and press the Enter Key.
To enter an existing file name, press the End Key or Ctrl+M Keys to display the current file names, select the required file name with the cursor, and press the Enter Key.
3. If the input file name already exists, a message will ask if the file should be overwritten. Press the Y and Enter Keys to overwrite the file. Press the Enter Key to cancel and input a new file name.
The title input area will appear when the Enter Key is pressed.
4. Input the title and press the Enter Key. The title can be up to 30 characters long.
The PC ID data will be saved when the Enter Key is pressed.

Note Enter the file name as up to 8 characters. Lower-case characters are converted to upper-case. A single directory name can have up to 8 characters with a total of 66 characters for the entire path name. See 6-2 *File Management* for more information about directories.

4-7-5 Retrieving PC IDs

- 1, 2, 3... 1. Select "R:Retrieve PC ID" from the Edit PC ID menu. A file name input area will be displayed.

2. Enter the file name and press the Enter Key. Press the End Key or Ctrl+M Keys to display the file names, select the required file name with the cursor, and press the Enter Key to input the file name.

The PC ID data will be retrieved when the Enter Key is pressed.

4-7-6 FILL

1. Select "I:FILL" from the Edit PC ID menu.

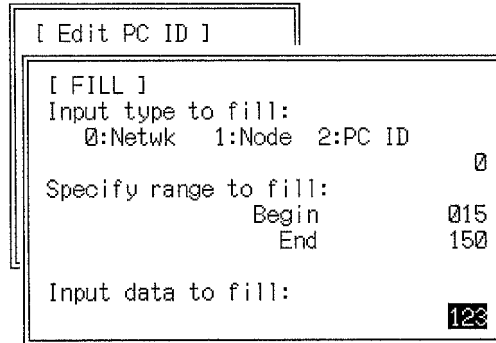

2. Specify in which column the data is to be entered, the range of rows, and the data.
3. Press the Enter Key.
The specified data will be written in the PC ID table when the Enter Key is pressed.

4-7-7 Clearing PC IDs

- 1, 2, 3... 1. Select "C:Clear" from the Edit PC ID menu.

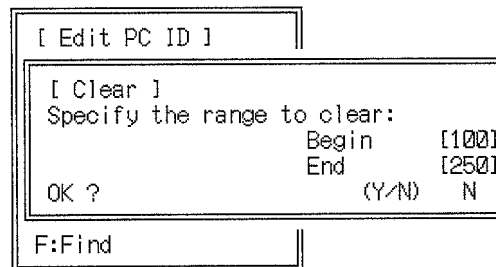

2. Specify the range of rows to clear.
3. Press the Y and Enter Keys to clear the data.
or Press the Enter Key to cancel the clear operation.

4-7-8 Printing PC IDs

Before printing, connect the printer and turn power on so that the printer is ready to print.

- 1, 2, 3... 1. Select "P:Print" from the Edit PC ID menu to start printing.
2. Press the Esc Key to cancel printing and return to the main menu. All characters in the print buffer will be printed before printing stops.

Sample Print-out

PC ID Dir 27/12/91 PAGE = 001

R	Netwk	Node	PC ID	R	Netwk	Node	PC ID	R	Netwk	Node	PC ID
001	001	001	blue								
002	001	002	red								
003	001	003	yellow								
004	001	004	green								
005	002	001	white								
006	002	002	black								
007	003	001	grey								
008	003	002	pink								
009	004	001	orange								

4-7-9 Checking PC IDs

- 1, 2, 3... 1. Select "K:Check" from the Edit PC ID menu to check for duplicated nodes and PC IDs in the network.
- Error messages will be displayed if errors are found. A message will indicate if no errors were found.
2. Press the Esc Key or the Shift+Esc Keys to return to the read mode.

Sample Error Message Screen

< > Check Edit PC ID

R	Netwk	Node	PC ID	Error message
001	001	001	red	Dup node
002	001	001	blue	Dup node
003	001	004	cat	Dup PC ID
004	001	003	cat	Dup PC ID

End

If errors are displayed, select the change mode, correct the PC ID data, and run the check again.

4-7-10 Sorting PC IDs

Select "O:Sort" from the Edit PC ID menu to sort the data.

The data will be sorted in the following order: network, node, PC IDs. PC IDs will be sorted in numerical and alphabetical order.

4-7-11 Finding PC IDs

- 1, 2, 3... 1. Select "F:Find" from the Edit PC ID menu to display the message shown in the diagram.

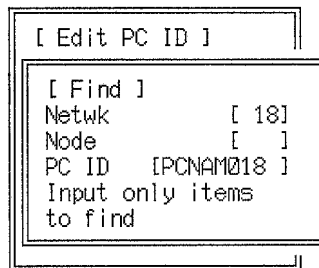

2. Enter the the network, node, or PC ID data to be found and press the Enter Key.
The cursor will move to the row containing the search string.
The read mode will be entered if no matching data is found.
3. Press the Enter Key to skip to the next instance of the search string.
or Press the Esc Key or the Shift+Esc Keys to return to the read mode.

SECTION 5

Data

This section provides the procedures required to display and print data lists. Data can also be read from a data disk or hard disk by performing a data trace. Data area lists and data tracing are performed using menus and examples of their use are provided. Read the CV-series PC Operation Manuals and Installation Guide before engaging in data operations.

5-1	Data Area Lists	194
5-1-1	Listing Used Data Areas	194
5-1-2	Listing Used Data Areas with I/O Comments	195
5-1-3	Listing Cross-references	195
5-1-4	Printing	196
5-2	Data Trace	197
5-2-1	Retrieving Data Trace Data	198
5-2-2	Reading Data Trace Data	198
5-2-3	Saving Data Trace Data	198

5-1 Data Area Lists

The following operations can be used to display and print tables of data related to programs on the work disk. To display the main data area list menu, select "H:Data Area lists" from the initial menu.

```
[Data Ar. Lst]
S:Used data area
C:Used data areas w/ I/O Comments
X:Cross-references
T:Print used areas
D:Print used areas with I/O Comments
Y:Print cross-references
```

The following three types of data area list can be displayed and printed.

Operation	Function
Cross-references	Displays a table showing the addresses and instructions that use specified bits or DM words on the work disk.
Used Data Areas	Displays sequentially the way in which bits, timers, counters, DM words, SFC steps, transitions, and actions are used in programs.
Used Data Areas with I/O Comments	Displays operating conditions including I/O name and I/O comments.

Note In the used data area and used data areas with I/O comments, step flags and transition flags used only in ladder diagrams and not in the SFC will not be displayed or printed.

5-1-1 Listing Used Data Areas

- 1, 2, 3... 1. Select "S:Used data area" from the Data Area Lists menu.
2. Specify the area. Press the Enter Key to list all addresses from CIO 0000 to 2555.
 - or Press the F2 Key to specify a different area. Press the function keys F1 to F9 according to the function key menu to specify the memory area to be listed, and press the Enter Key.

Press the F10 Key to switch to custom data area settings (See 7-3 Customizing Function Codes and Data Areas).
3. Enter the address of the first word to be read and press the Enter Key.

The used data area lists will be displayed from the input word address.
4. Press the PgDn and PgUp Keys to display the previous and next pages of the display.
 - or Press the Esc and Shift+Esc Keys to return to the Data Area Lists menu.

Sample List

Bit	15	14	13	12	11	10	09	08	07	06	05	04	03	02	01	00
Word																
0000					I			I	I	*	I				I	I
0001															I	I
0002											0				I	I
0003																0
0004																
0005														I	*	*
0006																*
0007																
0008																
0009																
0010																
0011																
0012																
0013																
0014																
0015																

I: IN , 0: OUT , *: both , space: unused

5-1-2 Listing Used Data Areas with I/O Comments

- 1, 2, 3... 1. Select "C:Used data areas W/ I/O Comments" from the Data Area Lists menu.
2. Specify the area or word addresses as described for listing used data. Custom data areas can also be specified, or I/O names can be specified instead of word addresses. Press the F9 Key to input an I/O name and then press the Enter Key.

The used data list and I/O comments will be displayed for the specified words.

Sample List

Bit	I/Oname	Comment
00	I ALARM0	Alarm Input 0
01	I ALARM1	Alarm Input 1
02	I ALARM2	Alarm Input 2
03		
04		
05	I	
06	I	
07	I	
08	I	
09		
10		
11	I	
12		
13		
14		
15		

I: IN , 0: OUT , *: both , space: unused

5-1-3 Listing Cross-references

- 1, 2, 3... 1. Select "X:Cross-references" from the Data Area Lists menu.
 2. Specify the area. Press the Enter Key to list cross-references for all addresses from CIO 0000 to 2555.
 - or Press the F2 Key to specify a different area. Press the function keys F1 to F9 according to the function key menu to specify the memory area to be listed and press the Enter Key.
- Press the F10 Key to switch to custom data area settings (See 7-3 Customizing Function Codes and Data Areas).
3. Enter the address of the first word address to be read and press the Enter Key.

The instructions using the specified bits will be listed sequentially in order of the addresses.

Cross-references for SFC programs appearing on the screen are listed separately for the SFC area and each action and transition number. If you use

the F1, F2, or F3 Keys to select the SFC area or an action and transition number, only cross-references in the designated area or number will appear on the screen. If SFC is not used, ladder programs are listed as separate blocks. Press the PgDn Key to scroll down the pages of the displayed lists.

Note When SFC are not used, ladder programs are listed as separate blocks allocated action numbers as shown in the table below. The action number is displayed at the top-right of the screen.

Block name	Action number
Main	AC0000
I/O interrupt 0	AC0001 to AC0032
Scheduled interrupt 0	AC0033 AC0034
Power off interrupt	AC0035
Power on interrupt	AC0036

Sample List

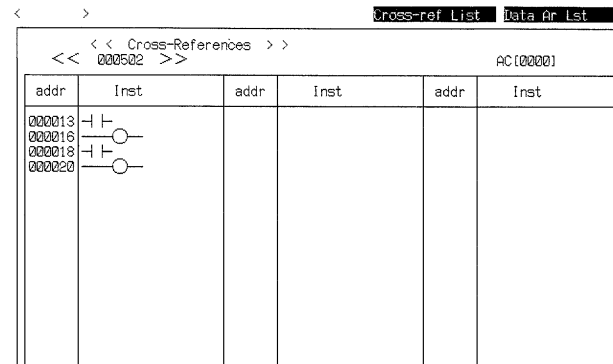

5-1-4 Printing

Printing Used Data Areas

- 1, 2, 3... 1. Select "T:Print used areas" from the menu.

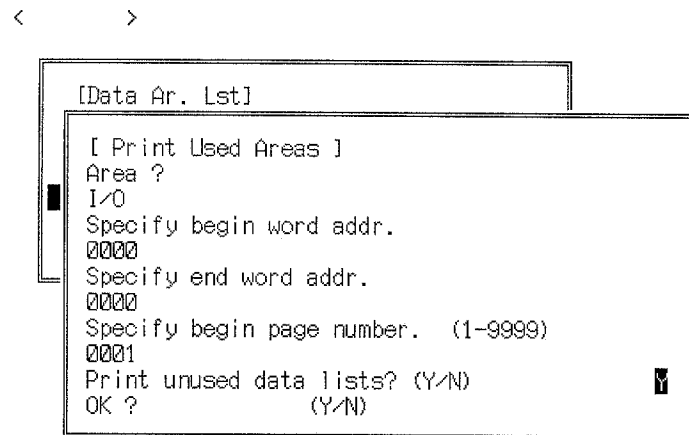

2. Specify the area to be printed as described in the section *Listing Used Data Areas*.
3. Input the start and end addresses of the printing range.
4. Input the starting page number for printing.

5. Specify whether or not to print unused data areas.
6. Press the Y and Enter Keys in response to the confirmation message to start printing.
The Data Area Lists menu will be displayed when the printing is complete.

Printing Used Data Areas with I/O Comments

Follow the procedure described above in the section *Printing Used Data Areas*.

Printing Cross-reference Lists

- 1, 2, 3... 1. Select "Y:Print cross-references" from the menu.

```

[Data Ar. Lst]
[ Print Cross-References ]
Area ?
I/O
Specify begin word addr.
Specify end word addr.
Specify begin and end action addr. (A:ALL,N:None)
Specify begin and end transition addr. (A:ALL,N:None)
Specify begin page number. (1-9999)
OK ? (Y/N)

```

2. Specify the area to be printed as described in the section *Listing Cross-references*.
3. Input the start and end addresses of the printing range.
4. Input the start and end actions and transitions.
5. Input the starting page number for printing.
6. Press the Y and Enter Keys in response to the confirmation message to start printing.
The Data Area Lists menu will be displayed when the printing is complete.
Cross-references are searched for and the list compiled before printing starts. This may take over 10 minutes.
It is not possible to print all areas simultaneously. Print the required areas individually.
7. Press the Shift+Esc Keys to cancel the printing and return to the sub-menu.
All characters in the print buffer will be printed before printing stops.

Note Printing will take a very long time if you designate a wide range of addresses. Be sure not to designate unnecessary addresses such as ones that the program does not include.

5-2 Data Trace

The following operation is used to read from the data disk or hard disk data resulting from a data trace performed online and display them on the screen.

The following online procedures are required before a data trace can be read.

- a) Run the data trace.
- b) Read the data trace.
- c) Save data trace data to disk.

Refer to the *CV Support Software Version 2: Online* for details.

- 1, 2, 3... 1. Select "T:Data trace" from the initial menu. The Data Trace menu will be displayed.

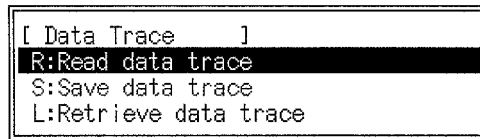

2. Select the required operation.

Data Trace Menu Operations

Operation	Function
Read data trace	Display data trace data from the work disk. Retrieve the data trace data from the data disk or hard disk before using this operation.
Retrieve data trace	Retrieve the data trace data from the data disk or hard disk to the work disk.
Save data trace	Save the data trace data from the work disk to the data disk or hard disk.

5-2-1 Retrieving Data Trace Data

- 1, 2, 3... 1. Select "L:Retrieve data trace" from the Data Trace menu. A file name input area will be displayed.
2. Enter the file name and press the Enter Key. Press the End Key or Ctrl+M Keys to display the file names, select the required file name with the cursor, and press the Enter Key to input the file name.
3. Press the Enter Key to retrieve the data trace data.
The data trace data will be retrieved when the Enter Key is pressed. The retrieved data trace data will be displayed.

5-2-2 Reading Data Trace Data

- 1, 2, 3... 1. Select "R:Read data trace" from the Data Trace menu.
The parameters set using the Run data trace on-line operation will be displayed.
2. Data trace data cannot be read if no data trace data exists on the work disk. First retrieve data to the work disk with the Retrieve data trace operation.
3. Press the Enter Key to display the read screen.
Subsequent operations are identical to operations for the Read data trace online operation. Refer to the *CV Support Software Version 2: Online* for details.

5-2-3 Saving Data Trace Data

- 1, 2, 3... 1. Select "S:Save data trace" from the Data Trace menu. A file name input area will be displayed.
2. Enter the file name and press the Enter Key.
To enter an existing file name, press the End Key or Ctrl+M Keys to display the current file names, select the required file name with the cursor, and press the Enter Key.
3. If the input file name already exists, a message will ask if the file should be overwritten. Press the Y and Enter Keys to overwrite the file or press the Enter Key to cancel and input a new file name.
The data trace data will be saved when the Enter Key is pressed. The menu will be displayed when the save operation is complete.

Note Enter the file name as up to 8 characters. Lower-case characters are converted to upper-case. A single directory name can have up to 8 characters with a total of 66 characters for the entire path name. See *6-2 File Management* for more information about directories.

SECTION 6

Files

This section provides the procedures required to manage files and perform UM conversion. These operations are performed using menus and examples of their use are provided. Read the CV500/CV1000 Operation Manuals and Installation Guide before engaging in file operations.

6-1	Initialization	202
6-2	File Management	203
6-2-1	File Directories	204
6-2-2	Copying Files	204
6-2-3	Renaming Files	205
6-2-4	Deleting Files	205
6-2-5	Changing the Drive and Path Name	205
6-2-6	Creating and Deleting Directories	205
6-2-7	Printing	206
6-3	UM Conversion	207
6-3-1	SFC or Ladder Program to UM	208
6-3-2	UM to SFC or Ladder Program	211
6-4	Comparing Programs	211
6-5	Memory Card Operations	213
6-5-1	Memory Card Menu	214
6-5-2	Initialization	215
6-5-3	Transferring to/from Memory Cards	215
6-5-4	Copying Files	215
6-5-5	Renaming Files	215
6-5-6	Deleting Files	215
6-5-7	Printing	216

6-1 Initialization

The following operations can be used to format a floppy disk to enable it to store data. Use 3.5-inch (2HD or 2 DD) or 5.25-inch (2HD or 2D) floppy disks. The storage capacity of floppy disks after initialization will be approximately 1.44M bytes for 3.5-inch 2 HD, 720K bytes for 3.5-inch 2DD, 1.2M bytes for 5.25-inch 2HD, and 360K bytes for 5.25-inch 2D floppy disks.

All existing data is cleared from a floppy disk during initialization.

Note For installation purposes, copy your computer's format command to the CVSS directory.

Procedure

- 1, 2, 3...**
1. Select "M:Format floppy" from the main offline menu with the cursor.
 2. Insert a floppy disk into the drive. Be sure the disk is not write-protected.

```
[ Formatting ]
Format floppy disk?
Warning:      Format will erase all data on the disk.
              Do not format the Hard Disk.
Are you sure you want to format?(Y/N)
```
 3. Press the Y and Enter Keys in response to the confirmation message to format the floppy disk.

```
[ Format command ]
Input the drive number and disk media parameter.
Format
```
 4. Specify the drive and floppy disk size. Press the Enter Key. Format the floppy disks with the parameters as shown in the following table.

It takes 1 to 2 minutes from the time the progress display appears to format a floppy disk.

Formatting cannot be stopped once it has been started.
 5. After formatting is complete, a message will ask the operator to press any key. Press the Enter Key to return to the drive selection display.
 6. To format another floppy disk, replace the floppy disk in the drive and repeat the procedure above from setup 3.
 7. When finished formatting, press the Esc Key or Shift+Esc Keys to return to the main offline menu.

Note This operation uses the FORMAT command in MS-DOS and must therefore be executed only where the FORMAT command is accessible and supported (e.g., the FORMAT command must be in the CVSS directory).

The following FORMAT commands can be used depending on the computer, floppy disk type, and disk storage capacity.

Model	Drive	Disk storage (K bytes)	Command
PS/2 (Ver 4.0)	3.5"	1,440	FORMAT A:
		720	FORMAT A:/N:9 /T:80
	5.25"	1,200	FORMAT A:
PS/2 (Ver 3.30)	3.5"	1,440	FORMAT A:
		720	FORMAT A:/N:9 /T:80
	5.25"	1,200	FORMAT A:
COMPAQ (Ver 4.0)	3.5"	1,440	FORMAT A:
		720	FORMAT A:/N:9 /T:80
	5.25"	1,200	FORMAT A:

Model	Drive	Disk storage (K bytes)	Command
T3200 (Ver 3.2)	3.5"	720	FORMAT A:
	5.25"	1,200	FORMAT A:
IBM PC/AT (Ver 3.2)	5.25"	1,200	FORMAT A:
		360	FORMAT A: /T40 /N:9

Note Refer to your computer's MS-DOS manual for details.

6-2 File Management

The following operations can be used to display, copy, rename, and delete files stored on data disks or the hard disk; to rename drives and paths; and to create, delete, and print directories.

Refer to the *CV Support Software Version 2: Basics* for details about file configurations and directories.

- 1, 2, 3...**
1. Insert the floppy disk into the drive.
 2. Select "F:File management" from the main offline menu.

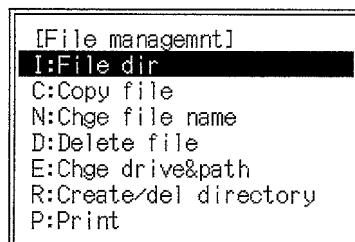

3. Select the required operation.
- or Press the Esc Keys or Shift+Esc Keys to return to the main offline menu.

File Management Menu Operations

Operation	Function
File dir	Displays directories for a total of 9 file types, including programs, DM, etc.
Copy file	Copies files.
Chge file name	Renames files.
Delete file	Deletes files.
Chge drive&path	Changes drive and path names to specify the current directory. The drive and path name set with this operation appear as the default values for save and retrieve operations.
Create/del directory	Creates a new directory in the current drive and path. Deletes the specified directory in the current drive and path.
Print	Prints the file name table for the specified files.

6-2-1 File Directories

- 1, 2, 3... 1. Select "I:File dir" from the main menu. The file selection menu will be displayed.

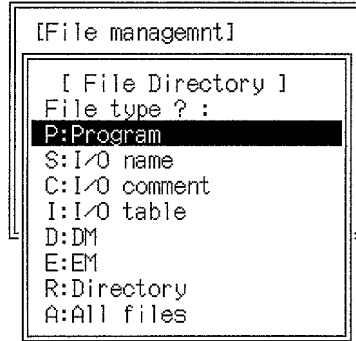

2. Select the required items. The file name table will be displayed for the selected files only.
If the file name table occupies more than one page, a message at the bottom-left of the screen will indicate there are more pages.
3. Press the Space Key to display the next page of the file name table. The first page will be displayed if the Space Key is pressed when the last page of the table is displayed.

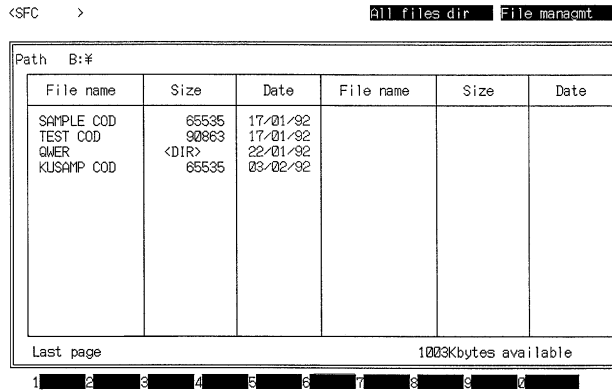

File name: The file name and type specified when the file was saved.
Size: The number of bytes the file occupies in memory. If <DIR> is displayed, the name is a directory name.
Date: Shows the date when the file was saved. Automatically appended when the file is saved.

Note Use "A:All files" to displayed partially saved ladder-diagram programs.

6-2-2 Copying Files

- 1, 2, 3... 1. Select "C:Copy file" from the main menu. The file selection menu will be displayed.
2. Select the required item. A file name input area will be displayed.
3. Enter the source file name. Press the End Key or Ctrl+M Keys to display the file names, select the required copy file name, and press the Enter Key twice.
The directory name can be included in the file name.
4. Enter the new file name and press the Enter Key. The directory name can be included in the file name.

If the name of an existing file is specified as the destination file name when copying from one drive to another, the existing file will be overwritten with no warning.

The file name table cannot be displayed by pressing the End Key or Ctrl+M Keys.

5. Press the Enter Key to start the copy operation.

The File Management menu will be displayed when the copy is complete.

It is not possible to copy a file to another file on the same drive with the same path name, file type, and file name.

6-2-3 Renaming Files

- 1, 2, 3... 1. Select "N:Chge file name" from the main menu. The file selection menu will be displayed.
2. Select the type of file to be renamed. A file name input area will be displayed.
3. Enter the name of the file to be renamed. Press the End Key or Ctrl+M Keys to display the file names, select the required file name, and press the Enter Key twice.

The directory name can be included in the file name but the directory cannot be renamed.

4. Enter the new file name and press the Enter Key to rename the file.

Restrict file names to 8 characters or less.

The File Management menu will be displayed after the file is renamed.

6-2-4 Deleting Files

- 1, 2, 3... 1. Select "D:Delete file" from the main menu. The file selection menu will be displayed.
2. Select the type of file to be deleted. A file name input area will be displayed.
3. Enter the file name of the file to be deleted. Press the End Key or Ctrl+M Keys to display the file names, select the required file name, and press the Enter Key twice.

The directory name can be included in the file name.

A confirmation message will be displayed.

4. Press the Y and Enter Keys to delete the file and return to the File Management Menu.

or Press the Esc Key or N and Enter Keys to cancel the file delete operation and return to the file selection menu.

6-2-5 Changing the Drive and Path Name

- 1, 2, 3... 1. Select "E:Chge drive&path" from the main menu. A drive and path name input area will be displayed.
2. Enter the drive and path names.
3. The floppy disk drive (drive A) will be displayed initially. Enter the directory name and press the Enter Key.
4. To change the drive name, press the Backspace Key to clear the A:\ display, then input the new drive name.

Path names may total up to 66 characters long.

The File Management Menu will be displayed after the drive and path names have been changed. Subsequently, the drive and path name set with this operation will appear as the defaults for save and retrieve operations.

6-2-6 Creating and Deleting Directories

- 1, 2, 3... 1. Select "R:Create/del directory" from the main menu. A menu will be displayed to select if the directory is to be created or deleted.

2. Select the required operation from the menu and press the Enter Key.

The message shown in the diagram will be displayed if "M:Create directory" is selected from the menu.

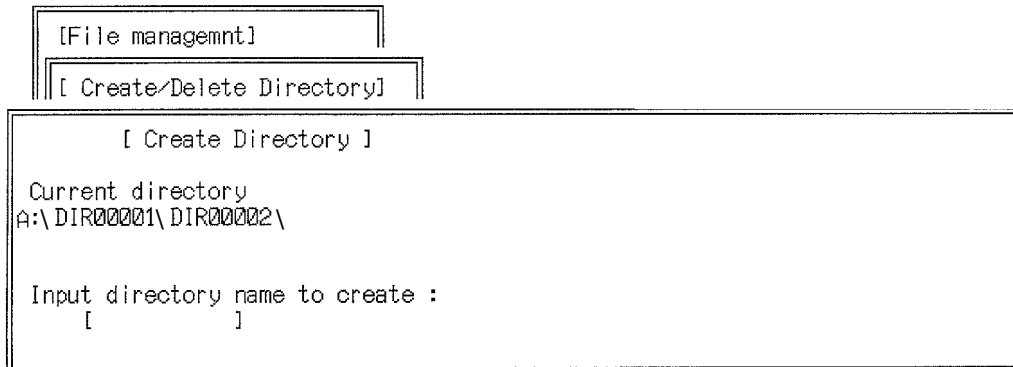

- The current directory drive and path name will be displayed. Create the main directory. Use the Chge drive&path operation on the main menu to change the default directory.
- Enter the file name as up to 8 characters and press the Enter Key. The File Management Menu will be displayed after the specified directory name is created.

The message shown in the diagram will be displayed if "R:Delete directory" is selected from the menu.

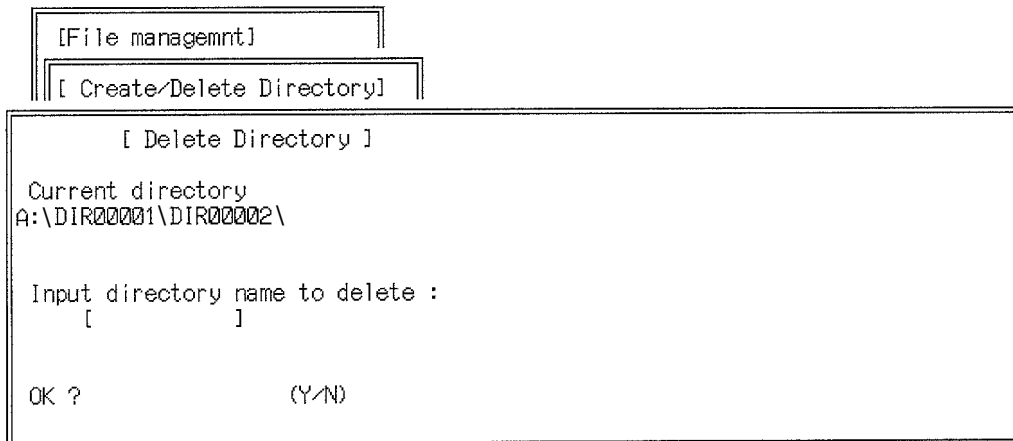

- The current directory drive and path name will be displayed. Directories within this directory can be deleted. Use the Chge drive&path operation on the main menu to change the default directory. Enter the file name as up to 8 characters and press the Enter Key. The specified directory cannot be deleted if it contains files or other directories.
- Press the Y and Enter Keys to delete the directory and return to the File Management Menu, or press the Esc Key or N and Enter Keys to return to the menu to select if a directory is created or deleted.

6-2-7 Printing

Before printing, connect the printer and turn power on so that the printer is ready to print.

- 1, 2, 3... 1. Select "P:Print" from the File Management menu. The file selection menu will be displayed.

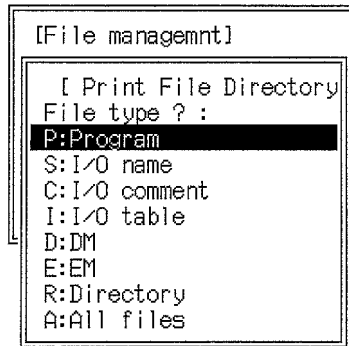

2. Select the type of file to be printed and press the Enter Key. The files corresponding to the specified file type will be printed. The Printing message will flash during printing.
3. Press the Esc Key to cancel printing and return to the menu. All characters in the print buffer will be printed before printing stops.

Sample Print-out

Print file dir
Path B:¥

27/12/91 10:33 PAGE = 001

File name	Size	Date	Time	File name	Size	Date	Time
SFCPRG COD	21817	02/10/91	17:02	PRINT RTG	125	26/12/91	20:46
SFCPRG OBJ	6308	02/10/91	16:55	PRINT PCN	5030	26/12/91	20:49
YOKO-1 COD	21814	03/10/91	14:56				
SFCSFT COD	21791	04/10/91	16:40				
AAA COD	22918	16/10/91	19:20				
SFC COD	21646	16/10/91	19:41				
SHTMAX-1 COD	21656	17/10/91	10:54				
AAA SBL	285	17/10/91	14:28				
MEMRYMAP COD	9793	18/10/91	16:14				
PCNAME PCN	5030	18/10/91	17:01				
LK3 SLK	4929	28/10/91	11:59				
LADDER COD	21636	29/10/91	11:48				
TADA SLK	4929	29/10/91	15:39				
DEKI SLK	4929	29/10/91	16:07				
DIR0001	<DIR>	30/10/91	13:34				
DIR0002	<DIR>	30/10/91	13:46				
ST17TN12 COD	21966	31/10/91	10:03				
GULDE COD	21968	01/11/91	18:43				
JIKKEN OBJ	12056	05/11/91	15:11				
JIKKEN DMD	49182	05/11/91	15:13				
JIKKEN CPU	888	05/11/91	15:13				
UMMAX COD	91199	06/11/91	13:51				
CV1 SNT	287	06/11/91	15:55				
TAMESI IOT	2402	08/11/91	11:31				
91-11-11 COD	22333	11/11/91	11:31				
G-B151 COD	21681	12/11/91	15:47				
PC1 RTG	125	25/11/91	16:18				
LK-1 SNT	287	26/11/91	10:29				
LK3-2 SLK	4929	26/11/91	14:11				
PCSETUP CPU	888	27/11/91	14:36				
PINKPIG RTG	125	27/11/91	16:49				
TRUE RTG	125	27/11/91	16:59				
KANAGAWA SLK	4929	28/11/91	11:47				
PCN04 COD	22487	28/11/91	15:08				
TADA LNK	193	17/12/91	14:52				
XMAS DMD	49182	17/12/91	15:30				
L100 IOT	2402	17/12/91	17:24				
NO-TOTCH SNT	287	18/12/91	20:16				
NORMAL SLK	4929	24/12/91	14:21				
SFC-TEST COD	24376	24/12/91	19:24				
SFC-TEST SBL	263	25/12/91	14:47				
SFC-TEST CMT	1187	25/12/91	15:54				
LAD COD	22036	26/12/91	19:41				
MNEMO COD	21771	26/12/91	19:46				
PRINT CMT	1088	26/12/91	20:31				
PRINT SBL	384	26/12/91	20:30				
PRINT LNK	1473	26/12/91	20:36				
PRINT DMD	49182	26/12/91	20:41				
PRINT SNT	287	26/12/91	20:43				
PRINT SLK	4929	26/12/91	20:44				

462 Kbytes available

6-3 UM Conversion

The following operations can be used to convert SFC or ladder programs on the work disk to PC machine language and store them on data disks or the hard disk, as well as to convert files of PC machine language on data disks or the hard disk to SFC or ladder programs and save them on the work disk.

Programs are stored on the computer work disk in the form of an intermediate code, whereas the programs in the PC are in the form of PC machine language. The UM conversion operations convert programs between these two codes.

The online transfer operations are used to transfer programs between the computer and PC. These are outlined in the following table. UM conversion is carried out before and after running the transfers from data disk (i.e., the last two in the table).

Online transfer operations	Functions and Characteristics
PC→Computer (System work) Computer (System work)→PC	Transfer programs between the work disk and the PC. Programs are stored on the computer work disk in the form of an intermediate code, and in the PC in the form of PC machine language. The programs are automatically converted between these two forms when a program is transferred. The time for conversion increases the transfer time.
PC→Computer (Data disk) Computer (data disk)→PC	Transfer machine language programs between the computer data disk and the PC. UM conversion is required before and after transfer of programs. The time required for these transfer operations is approximately half of the time required for the other two transfer operations.

To access the convert UM menu, select “U:Convert UM” from the main offline menu.



Note “U:SFC/ladder to UM” in the above display will read “U:SFC/ladder to UM (UM+HIS)” when an HIS program is currently registered.

Operation	Function and characteristics
SFC/ladder to UM	Converts intermediate code programs on the work disk to PC machine language and stores them on a data disk or the hard disk. In this case, .OBJ will be added as a file extension.
UM to SFC/ladder	Converts a PC machine language program, which has the file extension .OBJ, on a data disk or the hard disk to an intermediate code program and saves it on the work disk.

Run the program checks (see 2-9 *Checking SFC Programs* and 3-11 *Checking the Program*) before using the SFC/ladder to UM operation. The time for UM conversion depends on the size of the program. It may take over 4 minutes.

6-3-1 SFC or Ladder Program to UM

Make sure that the data disk or memory card has been formatted.

- 1, 2, 3... 1. Select “U:SFC/ladder to UM” from the Convrt UM menu. A menu will appear to select the PC model.

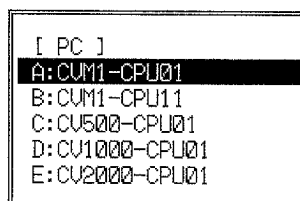

2. Select the PC model for the UM conversion. A setting screen will be displayed to set the conversion conditions. If SFC programming is not being used, only "P:Protect" will be displayed.

SFC+Ladder

```

[ Convrt UM ]
[ PC ]
[ SFC/ladder to UM ]
Conversion conditions :

S:Max. step/transitions      (Stan)
A:Max. actions              (Stan)
O:Space for SFC online edt  (No )
P:Protect                    (No )

OK ?                          (Y/N) 
    
```

Ladder Only

```

[ Convrt UM ]
[ PC ]
[ SFC/ladder to UM ]
Conversion conditions :

P:Protect                    (No )

OK ?                          (Y/N) 
    
```

3. To change a default setting, select the item to be changed with the cursor and change the setting.
The functions and settings are shown in the following table.
4. When the settings are complete, move the cursor to OK and press the Enter Key.

Item	Function and Setting
Max. step/transitions	The ladder program area can be expanded by restricting the maximum number of steps and transitions. Select the upper limit from the following values: CV500-CPU01-E: Standard, 256, 512 CV1000/CV2000-CPU01-E: Standard, 256, 512, 1024 The default setting is Standard. This sets the maximum number of steps/transitions for the PC model.
Max. actions	The ladder program area can be expanded by restricting the maximum number of actions. Select the upper limit from the following values: CV500-CPU01-E: Standard, 512, 1024 CV1000/CV2000-CPU01-E: Standard, 512, 1024, 2048 The default setting is Standard. This sets the maximum number of actions for the PC model.
Space for SFC online edt	The default setting is No, which stores SFC programs and ladder programs consecutively in the PC. If a space is set, the set amount of space is left between SFC and ladder programs stored in the PC. Setting the space for the SFC online editing reduces the time to append SFC programs with the online editing operations because it is not necessary to change the ladder program area.
Protect	The default setting is No, so that programs are not protected. If a protected program is transferred to the PC, it cannot subsequently be read or changed (including re-transfer to the computer) outside the PC. The protection can be set to cover the entire program or part of the program (by selecting up to 3 sheet, action, or transition numbers).

Maximum Steps and Transitions

Select the required setting with the cursor and press the Enter Key.

Maximum Actions

Select the required setting with the cursor and press the Enter Key.

Space for the SFC Online Editing

If space for SFC online editing is selected, set the size of the space in the range 1 to 65535 words.

Protection

SFC+Ladder

```

[ Convrt UM ]
  [ PC ]
    [ SFC/ladder to UM ]
      [ Protect ]
      Total protect password      12345678
      Part protect password      12345678
      Part protect range

      1 SFC sheet #      125
      2 SFC sheet #      511
      3 SFC sheet #      ****
      4 Ladder action/trans  AC0000 start 000000 end 123456
      5 Ladder action/trans  TN0001 start 000000 end 000001
      6 Ladder action/trans  **** start          end

      OK ?                      (Y/N)  
  
```

Ladder Only

```

[ Convrt UM ]
  [ PC ]
    [ SFC/ladder to UM ]
      [ Protect ]
      Total protect password      ****
      Part protect password      ****
      Part protect range

      1 Ladder Main/Intr      **** Begn      End
      2 Ladder Main/Intr      **** Begn      End
      3 Ladder Main/Intr      **** Begn      End

      OK ?                      (Y/N)  
  
```

- 1, 2, 3...**
1. Enter the passwords up to 8 hexadecimal characters.
 2. To partially protect a program when SFC programming is being used, specify up to 3 SFC sheet numbers and/or ladder program address ranges.

Setting ranges:

SFC sheet #	0 to 511
Action #	AC0000 to AC2047
Transition #	TN0000 to TN1023
Start-end address	0 to 999999

3. When SFC is not being used, specify the program block (see below) and address ranges to protect.

Blocks
Main
I/O interrupt 0 to 31
Scheduled interrupt 0, 1
Power off interrupt
Power on interrupt

A file name input area will be displayed after the conditions are set.

4. Enter the file name to be saved as up to 8 characters and press the Enter Key. Lower-case characters are converted to upper-case.
5. Press the Enter Key to save the file.
A message will flash during the conversion and the percentage completed will be displayed.
6. Press the Esc Key to cancel the transfer.
7. After the transfer is complete, press any key to return to the Convrt UM menu.

6-3-2 UM to SFC or Ladder Program

- 1, 2, 3... 1. Select "S:UM to SFC/ladder" from the Convrt UM menu. A file name input area will be displayed.
2. Enter the file name to be retrieved as up to 8 characters and press the Enter Key.
3. Press the End Key or Ctrl+M Keys to display the file names, select the required file name, and press the Enter Key twice.
A message will flash during the conversion and the percentage completed will be displayed.
4. Press the Esc Key to cancel the transfer.
5. After the transfer is complete, press any key to return to the Convrt UM menu.

6-4 Comparing Programs

The following operation can be used to compare a program file on a data disk to the programs held in the CVSS work area and display differences in a list.

The program file being compared must have a ".COD" extension.

The display of differences differs for ladder diagrams and SFC programs. For SFC programs, differences are given by sheet number and coordinates on the sheet.

<SFCLIMAX> SFC Compare prog.

Sht#	Differences
000	(00,003)
001	(00,004)
003	(00,001) (01,001) (03,001) (00,002) (01,002) (03,002) (04,002) (00,003) (01,003)
003	(03,003) (04,003) (00,004) (01,004) (03,004) (00,005) (01,005) (03,005)
010	(00,001) (01,001) (03,001) (00,002) (01,002) (03,002) (04,002) (00,003) (01,003)
010	(03,003) (04,003) (00,004) (01,004) (03,004) (00,005) (01,005) (03,005)
014	Only in SFC25.COD (compare file2)
015	(00,001) (01,001) (03,001) (00,002) (01,002) (03,002) (04,002) (00,003) (01,003)
015	(03,003) (04,003) (00,004) (01,004) (03,004) (00,005) (01,005) (03,005)
016	(00,001) (01,001) (03,001) (00,002) (01,002) (03,002) (04,002) (00,003) (01,003)
016	(03,003) (04,003) (00,004) (01,004) (03,004) (00,005) (01,005) (03,005)
030	(00,003) (01,003) (00,004) (00,005)
031	(00,004) (00,005)
100	Only in SFC25.COD (compare file2)
201	(00,002) (01,002) (01,003)
308	(00,002) (01,002) (00,003) (01,003) (00,004)
309	(00,004)

Continued next Page

1 2 3 4 5 6 7 8 9 0

For ladder diagrams, differences are given by address.

<SFCLDMAX> Ladder Compare prog.

AC/TN	Comp 1	Comp 2	AC/TN	Comp 1	Comp 2	AC/TN	Comp 1	Comp 2
AC0020	000192		AC0008	No	Yes	AC0024	No	Yes
AC0020	000193		AC0009	No	Yes	AC0025	No	Yes
AC0020	000194		AC0010	No	Yes	AC0026	No	Yes
AC0020	000195		AC0011	No	Yes	AC0027	No	Yes
AC0020	000196		AC0012	No	Yes	AC0028	No	Yes
AC0020	000197		AC0013	No	Yes	AC0029	No	Yes
AC0020	000198		AC0014	No	Yes	AC0030	No	Yes
AC0020	000199		AC0015	No	Yes	AC0031	No	Yes
AC0020	***** * 200*		AC0016	No	Yes	AC0032	No	Yes
AC0001	No	Yes	AC0017	No	Yes	AC0033	No	Yes
AC0002	No	Yes	AC0018	No	Yes	AC0034	No	Yes
AC0003	No	Yes	AC0019	No	Yes	AC0035	No	Yes
AC0004	No	Yes	AC0020	No	Yes	AC0036	No	Yes
AC0005	No	Yes	AC0021	No	Yes	AC0037	No	Yes
AC0006	No	Yes	AC0022	No	Yes	AC0038	No	Yes
AC0007	No	Yes	AC0023	No	Yes	AC0039	No	Yes

Continued next Page

Comp1 Current prog. Comp2 TEST.COD differences exceeded
 1 2 3 4 5 6 7 8 9 0

Messages

The following messages are displayed for differences found in the programs.

More than 36 differences on this sheet
Only in work disk program (comp file1)
Only in ?????????.COD (compare file 2)
More than 1,000 differences
Yes
No
(See note 1) * 200*
(See note 2) *1000*

- Note**
1. The number of differences exceed 200.
 2. The number of differences exceed 1,000.

Procedure

The procedure is as follows:

- 1, 2, 3... 1. Specify "G:Compare prog."

[Compare Programs]
 Input name of file to compare (comp file2)
 A: ¥

2. Place the data disk into the floppy disk drive.
3. Input the name of the program file to be compared and press Enter. The extension is not required. Example: TEST **Enter**.
4. Specify the type of programs to be compared, either ladder-only or SFC-only. A message will appear indicating that the comparison is being made.

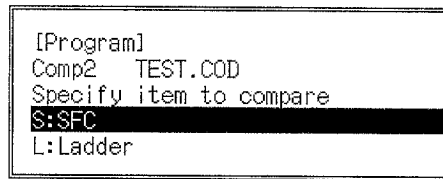

When the comparison is finished, a list of the differences, if any, will be displayed. If the list is too long to fit on one display, use the PgUp and PgDn Keys to scroll the display.

If there are no differences, "Data same" will be displayed.



- 5. Press SHIFT+ESC to return to step 1, above.
- or Press ESC to return to step 4, above.

6-5 Memory Card Operations

The following operations are used to manipulate files in the buffer RAM of the Memory Card Writer connected to the computer.

The operations from the computer affect only the Memory Card Writer buffer RAM. The operations do not affect the memory card directly. Refer to the Memory Card Writer operation manual for details on Memory Card Writer operation.

A Memory Card Writer is required to carry out the operations described in this section.

- 1, 2, 3...
1. Connect the Memory Card Writer to the computer, turn on the power supply, and press the online switch and start switch to enable operation. The Memory Card Writer display should show the online error code E0. The computer can now be operated.
 2. Select "J:Memory card" from the main offline menu. The files in the Memory Card Writer buffer RAM will be displayed.

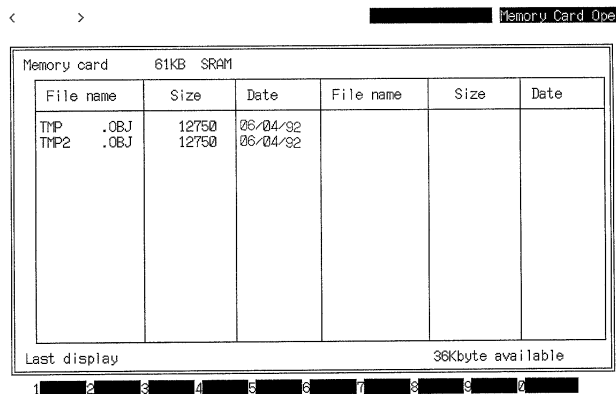

- File name:** The file name specified when the file was saved.
- Size:** The number of bytes the file occupies in memory.
- Date:** The date when the file was saved.

The date will be displayed as 00/00/80 for all files created for a memory card inserted in the Memory Card Writer. The date a file was saved will be displayed only for files created online for a memory card mounted in the CPU.

3. Up to 28 files can be displayed on a single page. Multiple pages are used to display more than 28 files. Press the PgDn Key to display the next page.
 4. Press the End Key or Ctrl+M Keys to return to the Memory Card menu.
- or Press the Esc Key or Shift+Esc Keys to return to the main offline menu.

6-5-1 Memory Card Menu

Press the End Key or Ctrl+M Keys to access the Memory Card menu and select the required operation. These operations are outlined in the following table and described in the following sections.

```
[ Memory Card Oper ]
M:Computer<->memory card
C:Copy file
N:Change file name
D>Delete file
F:Initialize
P:Print
```

Operation	Function and characteristics
Computer<—>memory card	Transfers files between the Memory Card Writer buffer RAM and the data disk or hard disk.
Copy file	Copies files in the Memory Card Writer buffer RAM.
Change file name	Renames files in the Memory Card Writer buffer RAM.
Delete file	Deletes files in the Memory Card Writer buffer RAM.
Initialize	Initializes the Memory Card Writer buffer RAM. Always use this operation to initialize new memory cards.
Print	Prints the file name for the files in the Memory Card Writer buffer RAM.

When the PC power is turned on, the user program and the PC Setup can be transferred from the memory card inserted in the CPU to the PC user program area. The files that can be transferred when the power is turned on are listed in the following table. To use this operation, save the files to be transferred to the memory card using the names shown in the table.

File type	File name
User program machine language file	AUTOEXEC.OBJ
PC system setting file	AUTOEXEC.STD

This operation can be selected in two ways:

- Setting the CPU's DIP switch pin #5: The user program file (AUTOEXEC.OBJ) and the PC Setup file (AUTOEXEC.STD) will be transferred.
- Setting in the PC Setup: Only the User program file (AUTOEXEC.OBJ) will be transferred.

The PC handles user programs in machine language. Therefore, use the UM conversion (see 6-3 *UM Conversion*) to save user programs created with the computer before setting this operation.

The PC Setup file must be transferred by the PC to a memory card then saved to a data disk. PC Setup files created at the computer then saved to the data disk cannot be used for this operation.

6-5-2 Initialization

- 1, 2, 3...
 1. Select "F:Initialize" from the main menu.
The memory card drive is drive #0.
 2. Press the Y and Enter Keys to initialize the memory card.
The Memory Card Menu will be displayed when initialization is complete.

6-5-3 Transferring to/from Memory Cards

Select "M:Computer<—>memory card" from the main menu, select the required transfer direction, and then proceed as shown in the following.

Transfer from Computer to Memory Card

- 1, 2, 3...
 1. Select "F:Computer—>memory card" from the menu. A file name input area will be displayed.
 2. Enter the name of the file to be transferred to the memory card. Press the End Key or Ctrl+M Keys to display the file names, select the required file name, and press the Enter Key twice.
 3. Enter the file name to be used in the memory card and press the Enter Key.
The previous menu will be displayed after the file is transferred to the Memory Card Writer buffer RAM.

Transfer from Memory Card to Computer

- 1, 2, 3...
 1. Select "M:Mem card—>Comp" from the menu.
A file name input area will be displayed.
 2. Enter the name of the file to be transferred from the memory card and press the Enter Key.
 3. Enter the file name to be used on the data disk or hard disk and press the Enter Key.
The previous menu will be displayed after the file is transferred to the data disk.

6-5-4 Copying Files

- 1, 2, 3...
 1. Select "C:Copy files" from the main menu. A file name input area will be displayed.
 2. Enter the source file name and press the Enter Key.
 3. Enter the destination file name and press the Enter key.
The initial screen will be displayed when the copy is complete.

6-5-5 Renaming Files

- 1, 2, 3...
 1. Select "N:Rename files" from the main menu. A file name input area will be displayed.
 2. Enter the file name to be changed and press the Enter Key.
 3. Enter the new file name and press the Enter Key.
The initial screen will be displayed when the file is renamed.

6-5-6 Deleting Files

- 1, 2, 3...
 1. Select "D>Delete file" from the main menu. A file name input area will be displayed.
 2. Enter the name of the file to be deleted and press the Enter Key. A confirmation message will be displayed.

3. Press the Y and Enter Keys to delete the file.
- or Press the Enter Key to cancel the file delete operation.

6-5-7 Printing

Select "P:Print" from the main menu. All files in the Memory card Writer buffer RAM will be printed and the initial screen will be displayed when printing is complete.

SECTION 7

Operating Parameters for the CVSS and PC

This section describes the various parameters that can be set to control CVSS and PC operation and provides the procedures to change these parameters from their default settings. The System Setup contains parameters that control CVSS operation, such as the type of program being created or the PC that will be connected to for online operations. The PC Setup contains a wide range of parameters that can be used to control PC operation, including settings for controlling word allocation and error treatment. The Customization operations enable usage of HIS programs, changing function codes, data area prefixes, and data area boundaries. Read the CV-series PC Operation Manuals and Installation Guide before using the CVSS.

7-1	System Setup	218
7-1-1	Communications Mode	218
7-1-2	Memory Card Writer	221
7-1-3	Program Type	221
7-1-4	Printer Type	221
7-1-5	Program Check PC	221
7-1-6	Message Number	221
7-2	PC Setup	221
7-2-1	PC System Setup	222
7-2-2	Saving the PC Setup	238
7-2-3	Retrieving the PC Setup	238
7-2-4	Clearing the PC Setup	239
7-3	Customization	239
7-3-1	HIS Programs	239
7-3-2	Customizing Function Codes and Data Areas	240

7-1 System Setup

The following procedure should be used to check and change the operating environment of the CVSS before initial operation. This procedure can also be used later on during operations to change the type of program, the model of PC, and any of the other parameters as required.

To start, select "Q:System setup" from the menu. The current settings of the CVSS operating environment will appear. Each of these parameters can be changed as described in the following subsections.

```
[ System Setup ]
N:Dest network addr (Net:000 Node:000 PC ID:      )
C:Comm use          (COM1) (Ascii )
R:Memory card writer (COM1)
T:Program type      (SFC+ladd)
P:Printer type      (WIDE CARRIAGE GRAPHICS)
K:Program check PC (CV1000-CPU01)
M:Message #         ( 0 )
```

Parameter	Function
Dest network addr	Specifies the PC that will be connected when the CVSS is placed online. If the PC connected to the CVSS is in a SYSMAC NET Link or SYSMAC LINK System, a remote PC can be connected. If the PC has been already specified, the PC name can be used for setting.
Comm use	Specifies the communications data type for the PC and computer to be connected. Select Binary to connect the PC's tool bus port and the computer using the CV500-CIF01 cable. To connect the PC's host interface port and the computer, select ASCII. After selecting the data type, specify the communications mode.
Program type	Specifies whether the program is to be written in ladder diagrams only or in SFC and ladder diagrams.
Memory card writer	Specifies the computer's communications port to which the Memory Card Writer is connected.
Printer type	Specifies the printer connected to the computer.
Prog check PC	Specifies the model of PC for which the program is being written.
Message #	Specifies the MSG(195) message number displayed on the CVSS.

Note If the PC is set as a CVM1, the program type must be set to ladder-only.

7-1-1 Communications Mode

Select "C:Comm use" from the System Setup menu. The following list of communications modes will appear. To connect the computer to the tool bus port of the PC through the CV500-CIF01, select Binary. Select ASCII to connect the computer to the host interface port of the PC.

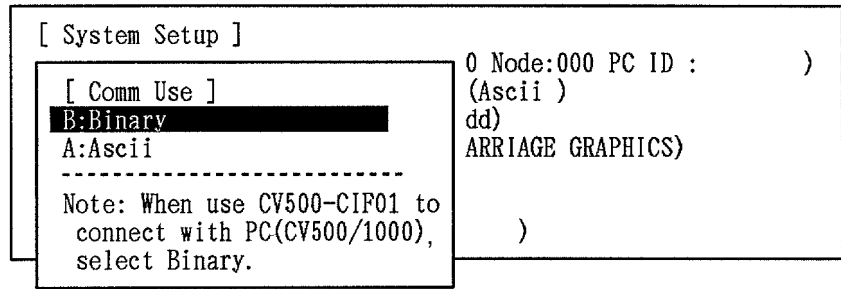

Binary

The following communications parameters appear when Binary is selected. The parameters determine the settings that will be used when communicating between the PC and the computer. These settings are for the computer and must agree with the settings for the PC (see the following).

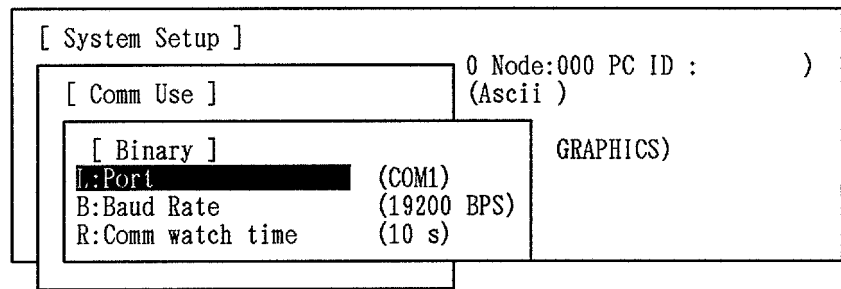

To change a parameter, select the item and then specify the desired settings on the display that will appear. The parameters and their possible settings are described in the following table.

Parameter	Function	Possible settings
Port	The computer port to which the PC is connected.	COM1 or COM2
Baud rate	The transmission speed.	Set to the value that has been set with the DIP switches on the front of the PC's CPU.
Comm watch time	The monitoring time for responses from the PC. An error will be generated if the PC does not respond within the specified time.	2 to 60 s

Follow the procedures mentioned below to connect the tool bus port on the PC's CPU and the computer.

- 1, 2, 3...**
1. Set the baud rate (19.2 kbps, 9,600 bps, or 4,800 bps) with DIP switches on the front of the PC's CPU for tool bus communication.
 2. Connect the CV500-CIF01 cable to the computer.
 3. Select Binary from the offline system setup menu and set the communications mode to 1.
 4. Connect the CV500-CIF01 cable to the tool bus port on the PC's CPU.
 5. Press the Shift+F1 Keys on the offline system setup menu to allow the PC to communicate online with the computer.

ASCII

The following communications parameters appear when ASCII is selected. The parameters determine the settings that will be used when communicating be-

tween the PC and the CVSS. These settings are for the CVSS and must agree with the settings for the PC (see the following).

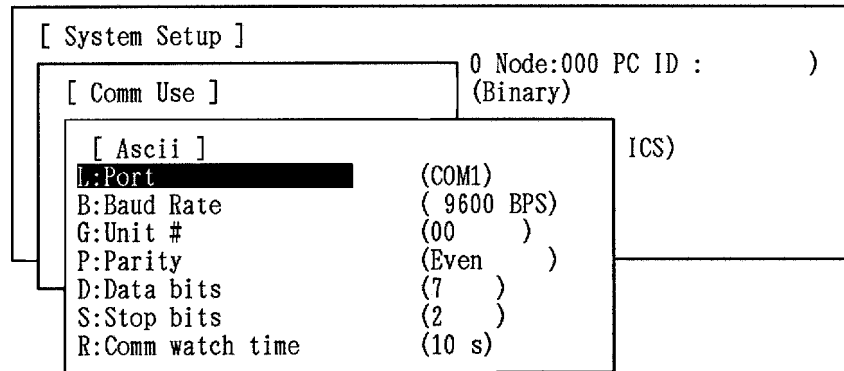

To change a parameter, select the item and then specify the desired settings on the display that will appear. The parameters and their possible settings are described in the following table.

Parameter	Function	Possible settings
Port	The computer port to which the PC is connected.	COM1 or COM2
Baud rate	The transmission speed.	Set to the value that has been set with the DIP switches on the front of the PC's CPU.
Unit #	The unit number of the PC for communications via the host interface.	00 to 31
Parity	The parity to be used for checking transmissions.	Even, odd, or no parity
Data bits	The data length to be used.	7 or 8 bits
Stop bits	The number of stop bits to be used.	1 or 2 bits
Comm watch time	The monitoring time for responses from the PC. An error will be generated if the PC does not respond within the specified time.	2 to 60 s

Follow the procedures mentioned below to connect the host interface port on the PC's CPU and the computer.

- 1, 2, 3...**
1. Set the transmission path selector on the CPU to RS-232C and turn ON pin 4 of the DIP switch on the CPU to automatically set the following parameters:
 - Baud rate: 4,800 bps
 - Parity: Even
 - Data length: 7 bits
 - Stop bits: 2
 2. Connect the computer running CVSS to the CPU's host interface port.
 3. Select ASCII from the offline system setup menu and set the communications mode to 1. Adjust the communications specifications to the above settings in the online mode. Then return to the offline mode.
 4. Set DIP switch 4 on the CPU to OFF. Then adjust the communications specifications to the above settings in the offline mode to allow the PC to communicate online with the computer.

7-1-2 Memory Card Writer

Select "R:Memory card writer" from the System Setup menu and specify the Memory Card Writer and the computer's communications port.

7-1-3 Program Type

Select "T:Program type" from the System Setup menu and specify the type of program to be written. To use SFC programming, select SFC+Ladder. To use only a ladder-diagram program, select Ladder.

If the program type is changed from SFC+ladder to ladder-only, a message will be displayed indicating that all programs will be erased and asking for confirmation. Input Y and press Enter to execution the change, erasing the programs.

7-1-4 Printer Type

Select "P:Printer type" from the System Setup menu and specify the type of printer connected to the computer.

Any of the following printers can be used depending on the specification.

Specification	Manufacturer	Model
Wide carriage graphics	IBM	4202-001
		4208-002
80-column graphics	IBM	4201-002
		4201-003
	Epson	FX-800
HP LaserJet II	HP	HP33471A

Note Set the job size and paper size with the control panel if the LaserJet II is to be used.

7-1-5 Program Check PC

Select "K:Program check PC" from the System Setup menu and specify the model of PC for which the program is written. The model that is specified will be used to determine data area limits and other criteria when checking the program.

7-1-6 Message Number

Select "M:Message #" from the System Setup menu and specify which message number is displayed on the CVSS for the MESSAGE instruction, MSG(195).

7-2 PC Setup

The PC Setup is used to specify operating parameters for the PC. Then the CVSS is offline, the PC Setup can be changed on the work disk, and it can be save to or retrieved from a data disk or the hard disk.

Note When the CVSS is online, PC Setup on the work disk can be transferred to the PC or the PC Setup in the PC can be changed directly

Select "A:PC setup" from the main offline menu. The first PC Setup menu will be displayed as shown below.

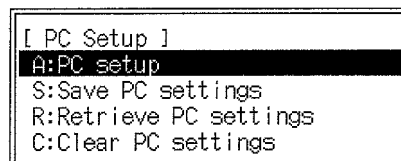

The use of each operation on this menu is described below.

Menu item	Function	Page
PC setup	Sets or changes the PC Setup on the work disk.	222
Save PC settings	Saves the PC system setup data on the work disk to a data disk or the hard disk.	238
Retrieve PC settings	Reads the PC Setup data from a data disk or the hard disk and saves it to the work disk.	238
Clear PC settings	Sets all parameters in the PC Setup on the work disk to their default values.	239

7-2-1 PC System Setup

To change any of the parameters in the PC Setup on the work disk, select "A:PC setup" from the first PC Setup menu. The following list of parameters will appear.

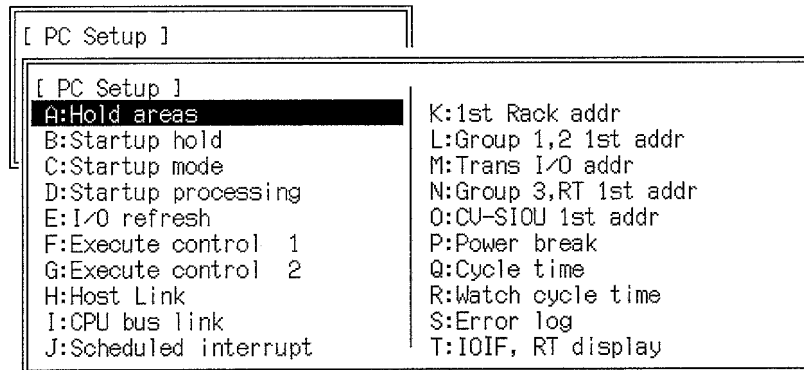

Any of the above parameters can be changed by selecting it from the list and inputting data according to the displays that will appear. The displays that appear when each parameter is selected are described beginning on page 229 after the following tables.

The following tables list the parameters in the PC Setup, provide examples of normal application, and provides the default values.

PC Setup Overview

Letter	Name	Function	Normal application(s)	
A	Hold areas	Hold area	To specify which bits are to maintain status when power is turned off.	To extend the Holding Area beyond CIO 300.
		Hold Racks (Hold bits)	To specify Racks or Masters (Remote I/O Subsystems) that are to maintain status when operation is stopped or modes are changed.	To maintain output status for specific Racks or Remote I/O Subsystems.
B	Startup hold	Forced Status Hold Bit status (A00013) (Forced status)	To maintain the status of the Forced Status Hold Bit when power is turned off and on.	To maintain the status of bits forced ON or OFF.
		IOM Hold Bit (A00012) status (I/O bits)	To maintain the status of the IOM Hold Bit when power is turned off and on.	To prevent I/O status from being cleared when power is turned on.
		Restart Continuation Bit status (A00011) (Power on flag)	To maintain the status of the Restart Continuation Bit when power is turned off and on.	These parameters must be set to YES when using restart continuation.
C	Startup mode	To specify the initial PC operating mode.	To automatically start the PC when power is turned ON. Set the mode to MONITOR or RUN when using restart continuation.	

Letter	Name	Function	Normal application(s)	
D	Startup processing	To specify whether the user program is loaded from the Memory Card when power is turned on.	To enable using a ROM Memory Card without a backup battery.	
E	I/O refresh	To set the refresh method to cyclic, zero-cross, or scheduled.	To reduce the cycle time by using immediate refreshing or to reduce surge voltages for AC outputs.	
F	Execution controls 1 (Execute control 1)	Detect low battery	To specify detection of CPU battery errors.	To disable detection when batteries are not being used.
		Error on power off	To specify if momentary power interruptions are to be treated as errors.	To generate an error for momentary power interrupts when they adversely affect system operation.
		CPU standby	To specify whether the CPU is to go on standby or start operation while initializing the system or detecting terminators in SYSMAC BUS/2 Systems.	
		Measure CPU Bus Unit (CPU SIOU) cycle	To specify whether or not the CPU Bus Unit servicing cycle is to be measured.	
G	Execution controls 2 (Execute control 2)	Execute process	To specify whether Peripheral Devices are to be serviced synchronously or asynchronously with program execution.	To increase processing capacity (speed) by using asynchronous processing.
		I/O interrupts	To specify whether higher-priority I/O interrupts are to be executed before a current I/O interrupt.	
		Power OFF interrupt	To specify whether a power off interrupt is to be executed.	To save system status when power turns off.
		Duplicate action error	To specify whether an error is to be generated when the same action is executed simultaneously from two different locations in the program.	
		Step timer	To set the unit for the step timer to 0.1 or to 1 s.	
		Startup trace	To specify whether a trace is to be automatically executed when power is turned on.	
		Indirect DM binary/BCD (*DM BIN/BCD)	To specify whether indirect addresses are treated as binary (memory addresses) or BCD (data area addresses).	To enable indirectly addresses for the entire DM and EM areas by using binary addresses.
		Multiple use of JMP000	To specify where or not multiple JMP000 instructions can be programmed.	
		Comparison error process	To specify whether I/O verification errors are to be fatal or non-fatal.	
H	Host link	To set communications parameters for the host link interface.	These settings must be made when using the host link interface.	
I	CPU bus link setting	To specify whether or not CPU bus links are to be created.	To enable linking of two or more BASIC Units.	
J	Scheduled interrupt	To set the unit for setting the scheduled interrupt to 10.0, 1.0, or 0.5 ms.		
K	First words for local racks (1st Rack addr)	To set the first word for each of the CPU, Expansion CPU, and Expansion I/O Racks.	To simplify word allocations, to prevent changes in allocations, or to allow for expansion without changes in allocations.	
L	First words for group-1 and group-2 Slaves (SYSMAC BUS/2) (Group 1,2 1st addr)	To set the first word for group-1 and group-2 Slaves for each Master.	To prevent overlapping of word allocations when group-1 and group-2 Slaves require more than 50 words per Master.	
M	First words for I/O Terminals (Trans I/O addr)	To set the first word for I/O Terminals for each Master.	To separate I/O Terminal allocations from those for other Slaves.	

Letter	Name	Function	Normal application(s)
N	First words for Slaves Racks (SYSMAC BUS/2 and SYSMAC BUS) (Group 3 RT 1st addr)	To set the first word for each Slave Rack.	To simplify word allocations, to prevent changes in allocations, or to allow for expansion without changes in allocations.
P	Momentary power interruption time (Power break)	To set the length of time to be treated as a momentary power interruption.	To enable ignoring short primary voltage drops for poor power supplies.
Q	Cycle time	To set a minimum cycle time.	To eliminate irregular I/O delays.
R	Cycle time monitoring time (Watch cycle time)	To set a maximum cycle time.	To stop operation when a specified cycle time is exceeded or to enable longer cycle times by setting a high maximum.
S	Error log area	To set the number of records recorded and the words in which they are recorded.	To increase the number or error records that are maintained.
T	Display modes at startup (IORF, RT display)	To set the startup display mode for the 7-segment displays on I/O Control Units, I/O Interface Units, and SYSMAC BUS/2 Slave Racks.	

PC Setup Details

Letter	Name		Operation
A	Hold areas	Hold area	The status of bits specified here will be maintained when power is turned off and on. The holding bits can be set in any continuous range between CIO 1000 to CIO 2399. (Default: CIO 1200 to CIO 1499)
		Hold Racks (Hold bits)	The output status on Racks specified here or in all Slaves connected to Masters specified here will be maintained when operation is stopped or when PC operating modes are changed. Status will not be maintained for these outputs when power is turned off. Regenerate the I/O table or turn PC power off and on after changing this parameter. (Default: nothing held)
B	Startup hold	Forced Status Hold Bit status (A00013) (Forced status)	Specify whether the status of the Forced Status Hold Bit is to be maintained or reset to OFF when power is turned on. This setting is effective the next time the power is turned ON. (Default: A00013 turned OFF)
		IOM Hold Bit status (A00012) (I/O bits)	Specify whether the status of the IOM Hold Bit is to be maintained or reset to OFF when power is turned on. This setting is effective the next time the power is turned ON. (Default: A00012 turned OFF)
		Restart Continuation Bit status (A00011) (Power on flag)	Specify whether the status of the Restart Continuation Bit is to be maintained or reset to OFF when power is turned on. This setting is effective the next time the power is turned ON. (Default: A00011 turned OFF) The following settings are required to continue operation after a power interruption: IOM Hold Bit (A00012): ON and maintained Forced Status Hold Bit (A00013): ON and maintained IOM Hold Bit status: Hold Restart Continuation Bit status: Hold Startup mode: RUN Power OFF interrupt: Exists
C	Startup mode		Designate the PC operating mode to be set when PC power is turned ON. This setting is valid the next time the power is turned ON. (Default: PROGRAM)

Letter	Name		Operation
D	Startup processing		Designate whether the user program (AUTOEXEC.OBJ) is automatically transferred from the card to PC memory when the power is turned ON. DIP switch pin #5 on the CPU can be turned ON to transfer both the user program (AUTOEXEC.OBJ) and the PC setup (AUTOEXEC.STD). Refer to information on the Memory Card for details. (Default: Don't transfer)
E	I/O refresh		Designate the I/O refresh method as cyclic, zero-cross, scheduled, or immediate. Cyclic refreshing will occur once each cycle at the end for user program execution. Zero-cross refreshes are synchronized with the times the voltage of the commercial power supply is 0 V. Set this method to more accurately turn off outputs when using AC power supplies. Scheduled refreshes occur at a specific timer interval. The scheduled refresh interval must also be set. Set the execution interval between 10 and 120 ms. Fixed interval refresh is effective only when the program execution CPU is not synchronized with the communications CPU. Immediate refreshing is also possible using certain instructions from the user program. To refresh using only these instructions, set scheduled refreshes and then set the refresh interval to 00 ms. If this is done, I/O status will be refreshed only when instruction in the user program call for it. This setting is effective immediately. (Default: Cyclic)
F	Execution controls 1 (Execute control 1)	Detect low battery	Designate whether battery errors are detected. This setting is effective immediately. (Default: Detect) The following bits will be turned ON when a battery error is detected. A40204 Battery Low Flag (PC or memory card) A42614 Memory Card Battery Low Flag A42615 PC Battery Low Flag
		Error on power off	Designate whether a momentary power interruption is treated as an error. If momentary power interrupts are treated as errors, they will be recorded in the error log (see setting F). This setting is effective immediately. (Default: Non-fatal)
		CPU standby	Designate whether the CPU is placed on standby during initialization and until SYSMAC BUS/2 terminators are properly detected. (Default: CPU waits)
		Measure CPU-bus Unit (CPU SIOU) cycle	Designate whether or not the time between CPU-bus Unit services is to be measured. If measured, the cycle is stored starting at A310. This setting is effective immediately. (Default: Don't measure cycle)

Letter	Name	Operation	
G	Execution controls 2 (Execute control 2)	Execute process	Designate whether instruction execution and Peripheral Device servicing are to be carried out synchronously or asynchronously. If synchronous execution is used, IOM cannot be accessed from a Peripheral Device during user program execution. (Default: Parallel)
		I/O interrupts	Designate whether or not I/O interrupt execution is interrupted for higher-priority I/O interrupts. The I/O interrupt program with the lowest input number has highest priority. Power OFF interrupts, power ON interrupts, and scheduled interrupts take priority over I/O interrupts regardless of this setting. This setting is effective immediately. (Default: Nesting)
		Power OFF interrupt	Designate whether or not power OFF interrupts are generated. If an interrupt is generated, the power OFF interrupt program will be executed. This setting is effective immediately. (Default: Disable)
		Duplicate action error	Designate whether or not a non-fatal SFC error is generated when the same action is executed simultaneously from multiple program steps. This setting is effective immediately. (Default: Error)
		Step timer	Designate whether the step timer is set in increments of 0.1 s or 1.0 s. This setting is effective immediately. (Default: 0.1 s)
		Startup trace	Designate whether a trace is executed automatically according to the preset conditions when the power is turned on or the operating mode is changed. This setting is effective the next time power is turned on. (Default: Don't start trace)
		Indirect DM binary/BCD (*DM BIN/BCD)	Designate whether indirect DM and EM addresses are binary (PC memory addresses) or BCD (DM and EM area addresses). This setting is effective immediately. (Default: BCD)
		Multiple use of JMP000	To specify where or not multiple JMP000 instructions can be programmed. (Default: Multiple use of JMP000 enabled)
		Comparison error process	Designate whether or not to enable operation for I/O verification errors. Once the PC starts operating, the operation continues even if an I/O verification error has occurred. This setting is effective immediately. (Default: Run after error)
H	Host link	Baud rate	Designate 1200, 2400, 4800, 9600, or 19200 bps. (Default: 9600 bps)
		Stop bits	Designate either 1 stop bit or 2 stop bits. (Default: 2 stop bits)
		Parity	Designate even, odd, or no parity. (Default: Even parity)
		Data length (Data bits)	Designate either 7-bit or 8-bit data. (Default: 7-bit data)
		Unit number	Designate the unit number between 00 and 31. The unit number must not be the same as the unit number of another PC. This setting is effective immediately. (Default: 00)
I	CPU bus link setting	Designate whether or not CPU bus links are used. CPU bus links are used between BASIC Units only. The CPU bus link service interval is 10 ms. Any change in setting will be reflected immediately. (Default: Don't use CPU bus link)	
J	Scheduled interrupt interval	Designate whether the scheduled interrupt time is set in increments of 10.0 ms, 1.0 ms, or 0.5 ms. This setting is effective the next time the power is turned ON. (Default: 10 ms)	

Letter	Name	Operation
K	First words for local racks (1st Rack addr)	Designate the first word for each CPU, Expansion CPU, and Expansion I/O Rack. The first word can be set between 0 and 511. Do not allow word allocations to overlap. Recreate the I/O table after changing this setting. (Default: 0 for CPU Rack, no designation for other Racks (continue on from previous Racks))
L	First words for group-1 and group-2 Slaves (Group 1,2 1st addr)	Designate the first words for each Master for SYSMAC BUS/2 group-1 and group-2 Slaves to between CIO 0000 and CIO 0999. Recreate the I/O table after changing this setting. (Default: Group 1: 50 words per Master starting at intervals of 200 words with the first interval starting from CIO 200. Group 2: 50 words per Master starting at intervals of 200 words with the first interval starting from CIO 250.)
M	First words for I/O Terminals (Trans I/O addr)	Designate the first word for each Master for SYSMAC BUS I/O Terminals between CIO 0000 and CIO 2555. Allocations will not be changed unless the first word allocated to the Master is changed. Recreate the I/O table after changing this setting. Do not allow words allocated to these I/O Terminals to overlap with the bits set as holding bits. Outputs that are ON at the end of operation will remain ON when operation is stopped if I/O Terminals are allocated words also specified as holding bits. (Default: 32 words per I/O Terminal starting from CIO 2300)
N	First words for group-3 Slaves (Group 3 RT 1st addr)	Designate the first word for each SYSMAC BUS/2 group-3 Slave between CIO 0000 and CIO 0999 and for each SYSMAC BUS Slave Rack between CIO 0000 and CIO 2555. Recreate the I/O table after changing this setting. Do not allow words allocated to Slave to overlap with the bits set as holding bits. Outputs that are ON at the end of operation will remain ON when operation is stopped if Slaves are allocated words also specified as holding bits. (Default: Normal allocation using consecutive words)
P	Momentary power interruption time (Power break)	Designate the momentary power interruption time between 0 and 10 ms. Operation will continue for momentary power interruptions if the power supply is restored within this time after a power interruption. If the momentary power interruption time is set to greater than 0 ms, Peripheral Device communications may be disrupted and may go on standby for momentary power interruptions. This setting will be ignored and the default value will be used if a C500 Expansion I/O Rack is connected to the System. This setting is effective immediately. (Default: 0 ms)
Q	Cycle time	Set the minimum cycle time to between 0 and 32,000 ms. If the actual cycle time is less than the set cycle time, execution will be halted until the set cycle time elapses before the next scan is executed. If the actual cycle time exceeds the set cycle time, the setting is ignored and the next cycle is executed when the current cycle is complete. This setting is effective immediately. In the actual operation of the PC, there may be a deviation of 3 to 4 ms. If a break-in program is being executed, a further deviation due to the execution of the break-in program will be involved. (Default: Variable cycle)
R	Cycle time monitoring time (Watch cycle time)	Designate the maximum cycle time between 10 and 40,000 ms. If the cycle time exceeds this value, a fatal error will occur and A40108 will be turned ON (Cycle Time Too Long Flag). This setting is effective immediately. (Default: 1,000 ms)

Letter	Name	Operation
S	Error log area	Designate the size and range of the error log. When a error occurs, information about the error is saved in this memory area together with the time that the error occurred. Refer to the <i>CV500/CV1000 Operation Manual: Ladder Diagrams</i> for details about the error log. This setting is effective the next time the power is turned ON. (Default: 20 records of 5 words each in A100 to A199)
T	Display modes at startup (IOIF, RT display)	Designate the display mode to be used for the 7-segment displays on I/O Interface Units, the I/O Control Unit, and SYSMAC BUS/2 Remote I/O Slave Units when the power is turned ON. This setting is effective the next time the power is turned ON. (Default: Mode 1)

PC Setup Default Settings

Letter	Name	Default setting
A	Holding bits (Hold areas)	Hold area: CIO 1200 to CIO 1499 Holding Racks: Nothing held
B	Startup hold	Forced Status Hold Bit: Not held IOM Hold Bit: Not held Restart Continuation Bit: Not held
C	Startup mode	PROGRAM
D	Startup processing	User program not transferred.
E	I/O refresh	Cyclic refresh
F	Execution controls 1 (Execute control 1)	Detect low battery: Detect Power interruption: Fatal CPU standby: CPU waits (RUN waits) CPU-bus Unit cycle: Not measured
G	Execution controls 2 (Execute control 2)	CPU operation: Asynchronous us I/O interrupts: Nesting interrupts Power OFF interrupt: Disable Dup action process: Error Step timer: 0.1 s increments Startup trace: No Indirect DM: BCD Comparison error: RUN
H	Host link	Baud rate: 9,600 bps Stop bits: 2 Parity: Even Data length: 7 Unit number: 00
I	CPU bus links	No CPU bus links
J	Scheduled interrupt interval	10 ms
K	First words for local racks (1st Rack addr)	CPU Rack: 0000 Others: None
L	First words for group-1 and group-2 Slaves (Group 1,2 1st addr)	RM &0 RM &1 RM &2 RM &3 Group 1 0200 0400 0600 0800 Group 2 0250 0450 0650 0850
M	First words for I/O Terminals (Trans I/O addr)	RM &0 RM &1 RM &2 RM &3 RM &4 RM &5 RM &6 RM &7 2300 2332 2364 2398 2428 2460 2492 2524
N	First words for group-3 Slaves (Group 3 RT 1st adds)	Group-3 Slaves (SYSMAC BUS/2) RM #0 RM #1 RM #2 RM #3 0300 0500 0700 0900 SYSMAC BUS Systems RM #0 to RM #7 defaults are identical to those for I/O Terminals, above.
P	Momentary power interruption time (Power break)	0 ms
Q	Cycle time	Variable cycle

Letter	Name	Default setting
R	Cycle time monitoring time (Watch cycle time)	1,000 ms
S	Error log area	20 records of 5 words each, A100 to A199
T	Display modes at startup (IORF, RT display)	Mode 1

PC Setup Displays

Holding Bits

There are two settings for holding bits. The "hold areas" specifies the data areas or the parts of data areas for which status is held. The "hold bits" specify the Racks for which outputs are held. The current settings will be shown. Racks that are set are displayed in reverse video.

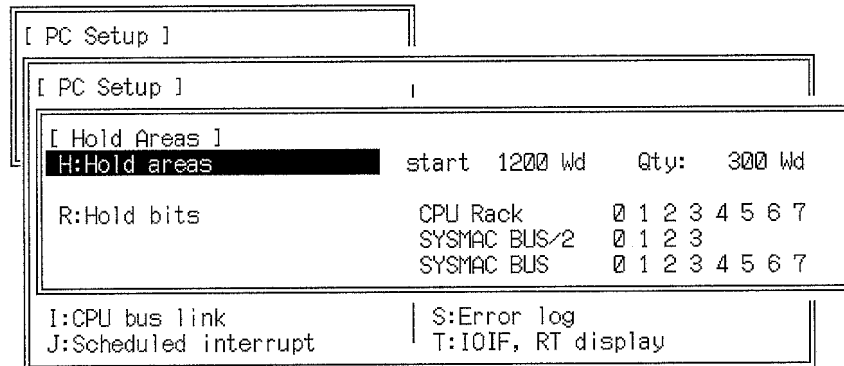

Hold Areas The following display will appear if "H:Hold areas" is selected. Specify the address of the first word in the CIO Area and the number of words that are to be held.

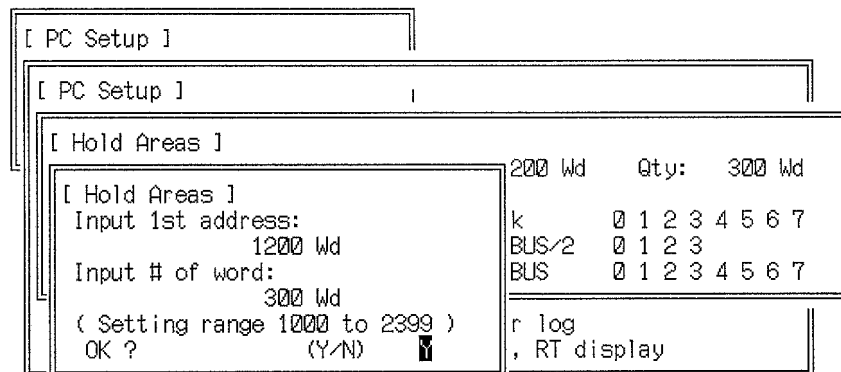

from the Memory Card, set the PC to start in RUN mode (see previously described *Startup Mode*).

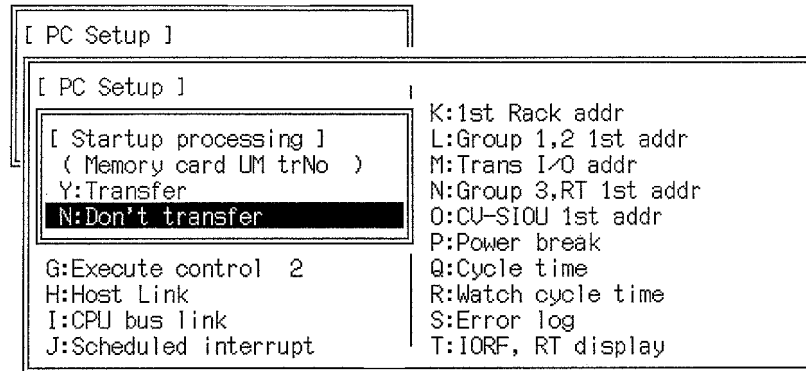

I/O Refresh

Specify the type of I/O refresh to be executed. If none of these refresh methods is to be used, select the scheduled refresh and set the refresh interval to 00.

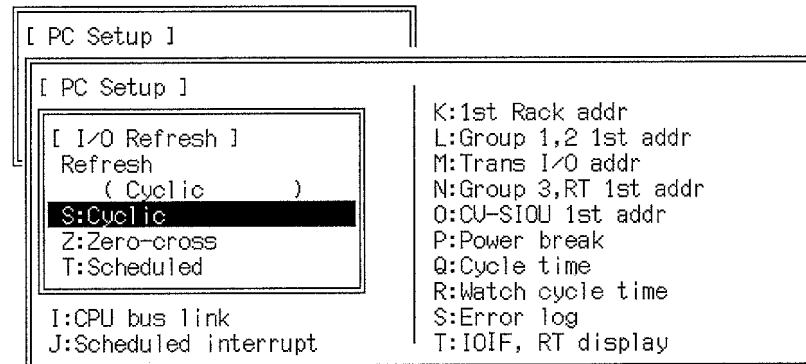

The refresh interval for the scheduled refresh can be set in increments of 10 ms between 10 and 120 ms. The scheduled refresh will not be executed if the interval is set to 00 ms.

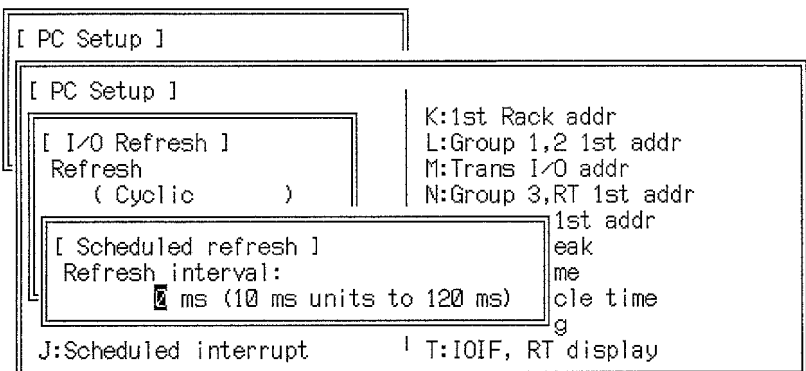

Execution Controls 1

There are four separate controls that can be set, as shown below. The current settings are displayed on the far right. To change a setting, select the item and select the desired treatment.

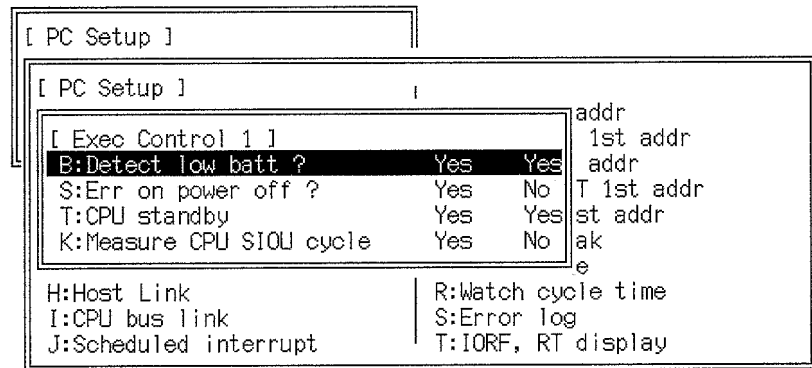

- Detect low batt:** Set to Yes to treat detection of a low CPU battery as an error.
- Err on power off:** Set to Yes to treat detection of a momentary power interruption as an error.
- CPU standby:** Set to Yes if you want the CPU to go on standby during system initialization.
- Measure CPU SIOU cycle:** Set to Yes if you want the CPU Bus Unit servicing cycle to be measured and stored in memory (A310 to A325).

Execution Controls 2

There are eight separate controls that can be set, as shown below. The current settings are displayed on the far right. To change a setting, select the item and select the desired treatment.

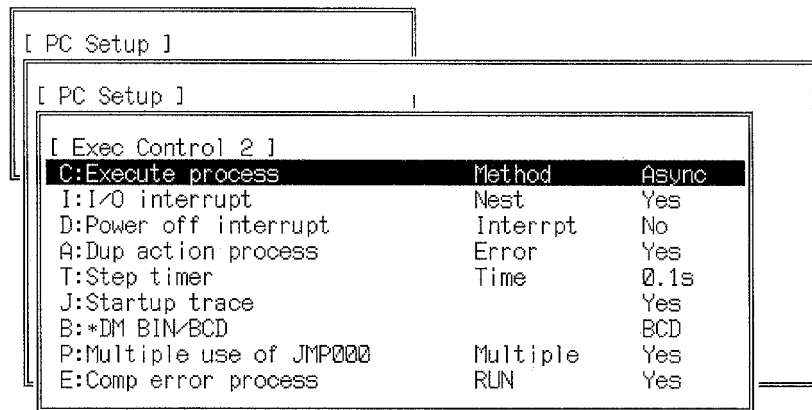

- Execute process:** Specify whether Peripheral Device servicing is to be executed synchronously or asynchronously with program execution.
- I/O interrupt:** Specify whether or not I/O interrupts are to be interrupted to executed higher-priority I/O interrupts.
- Power off interrupt:** Specify whether or not the power off interrupt is to be executed.
- Dup action process:** Specify whether or not an error is to be generated if the same action is executed simultaneously from two locations in the SFC program.
- Step timer:** Specify the unit for the step timer.
- Startup trace:** Specify whether or not a trace is to be automatically executed when PC power is turned on.
- *DM BIN/BCD:** Specify if indirect addresses are to be treated as binary or BCD.
- Multiple Use of JMP000:** Enables or disables usage of multiple JMP000 instructions.

Comp error process: Specify if I/O verifications errors are to be fatal or non-fatal.

Host Link

Set the communications parameters for the host interface. The current settings are given in parentheses. Refer to 7-1-1 *Communications Mode* for details on settings if the CVSS is connected to the host interface port.

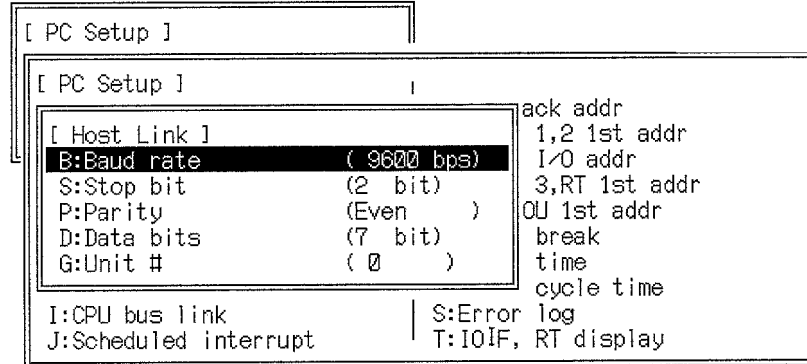

CPU Bus Links

Specify whether or not CPU bus links are to be used between BASIC Units (other CPU Bus Units do not use CPU bus links). If CPU bus links are used, the CPU bus link servicing cycle will be set to 10 ms.

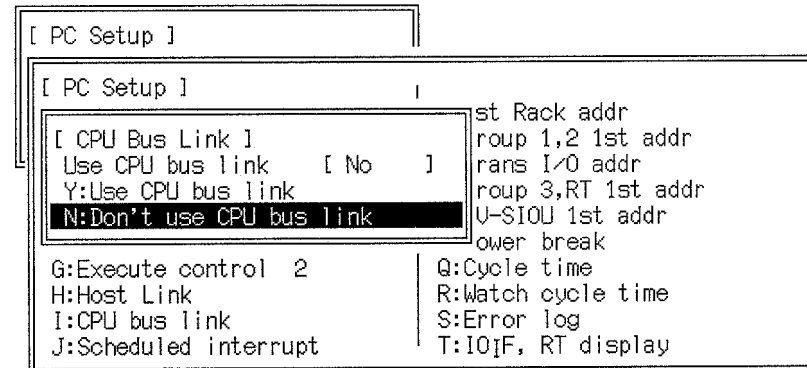

Scheduled Interrupt Interval

Select the interval for executing the scheduled interrupt. The current interval is displayed in parentheses.

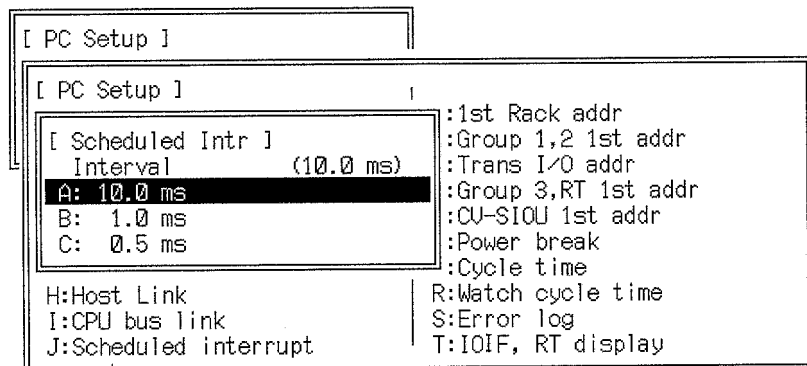

First Words for Local Racks

The following display is used to set the first word on each of the CPU, Expansion CPU, and Expansion CPU Racks. If these settings are not changed, words will be allocated according to the default setting.

To set the first words, press the N Key and then the Enter Key and then move the cursor to each rack number and input the first word for it. First words can be specified between 0000 and 0511. If the word display disappears, press the Home Key. When all the first words have been designated, move the cursor to the confirmation area and press the Enter key.

Any Racks for which first words are not designated will be allocated starting from CIO 000, possibly causing duplications in allocation and an I/O verification error.

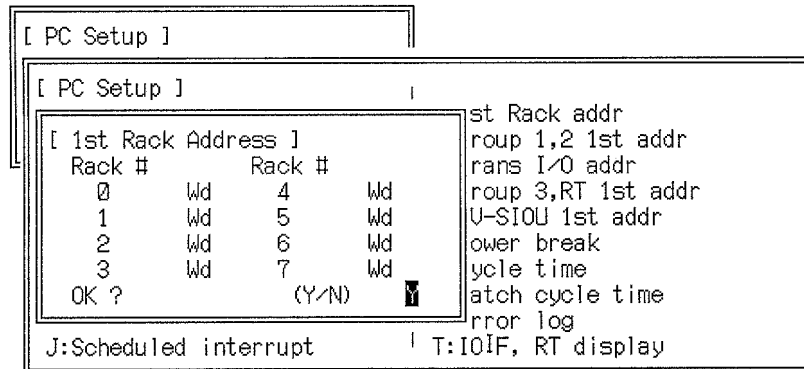

First Words for Group-1 and Group-2 Slaves

Select either group 1 or group 2 and the current settings will be displayed as shown below. If these settings are not changed, words will be allocated according to the default setting.

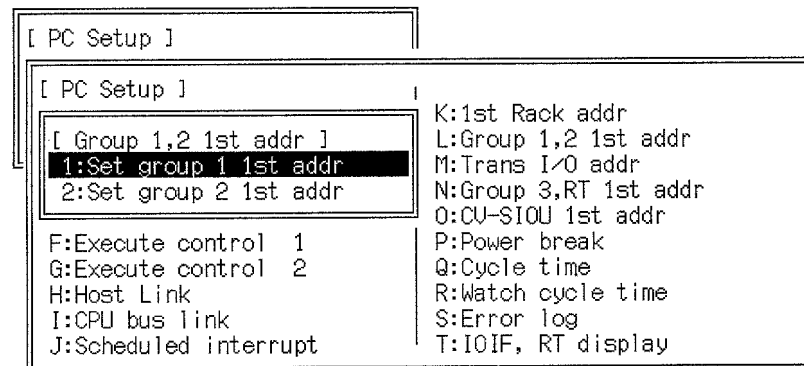

To specify the first words for either group, press the N Key and then the Enter Key and then move the cursor to each master number and input the first word for group-1 or group-2 Slaves under each Master. First words can be specified between 0000 and 0999. Be care not to set first words so that word allocations overlap. When all the first words have been designated, move the cursor to the confirmation area and press the Enter key.

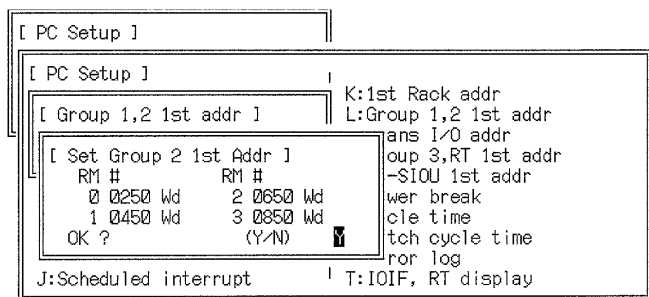
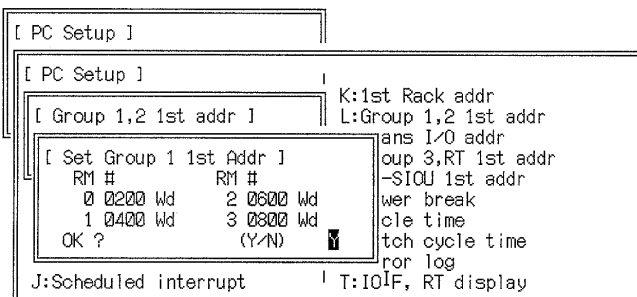

First Words for I/O Terminals The following display is used to set the first word the I/O Terminals under each Master. If these settings are not changed, words will be allocated according to the default setting.

To specify the first word under a Master, press the N Key and then the Enter Key and then move the cursor to each master number and input the first word for each Master. First words can be specified between 0000 and 2555. Be care not to set first words so that word allocations overlap. When all the first words have been designated, move the cursor to the confirmation area and press the Enter key.

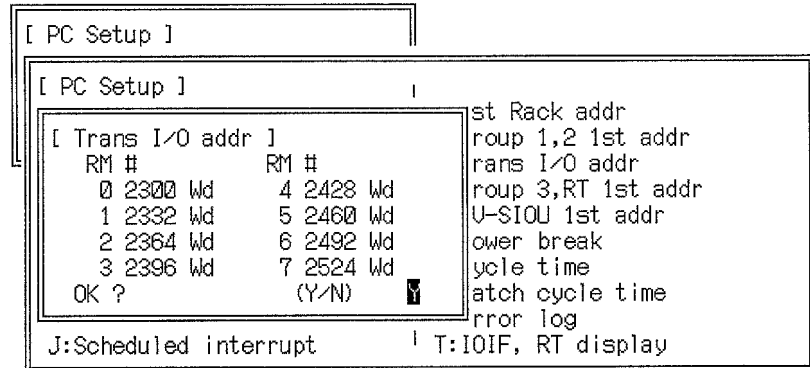

First Words for Group-3 Slaves

The first word can be set on each Slave Rack in a SYSMAC BUS or SYSMAC BUS/2 Remote I/O System. If these settings are not changed, words will be allocated according to the default setting. First, select the Remote I/O System.

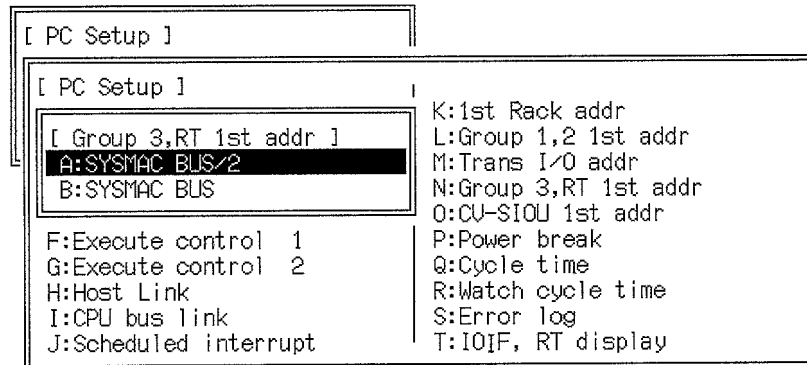

To specify the first words for either Remote I/O System, specify the Master on the following display.

SYSMAC BUS/2

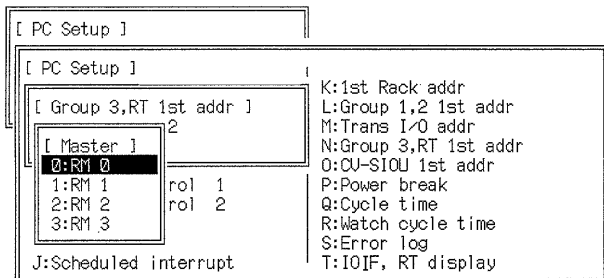

SYSMAC BUS

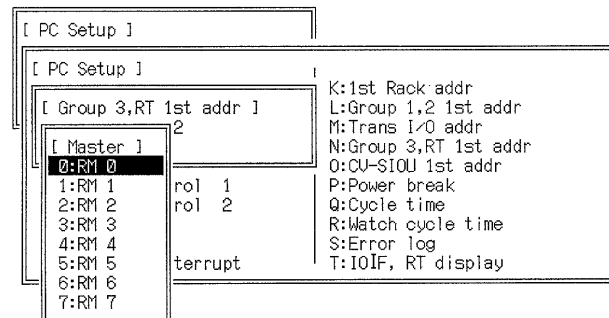

To change the first words, press the N Key and then the Enter Key and then move the cursor to each Slave unit number and input the first word for allocation on that Slave Rack. First words can be specified between 0000 and 0999 for the

SYSMAC BUS/2 and between 0000 and 2555 for the SYSMAC BUS. Be care not to set first words so that word allocations overlap. When all the first words have been designated, move the cursor to the confirmation area and press the Enter Key.

SYSMAC BUS/2

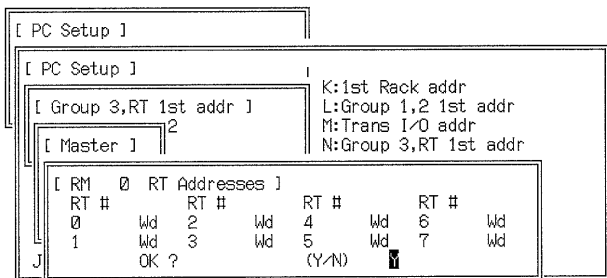

SYSMAC BUS

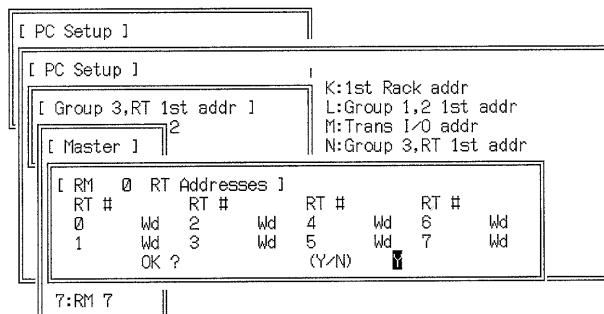

Momentary Power Interruption Time

Set the time to be considered a momentary power interruption. All interruptions shorter then the set time will be ignored. The setting can be between 0 and 10 ms. The current setting is displayed.

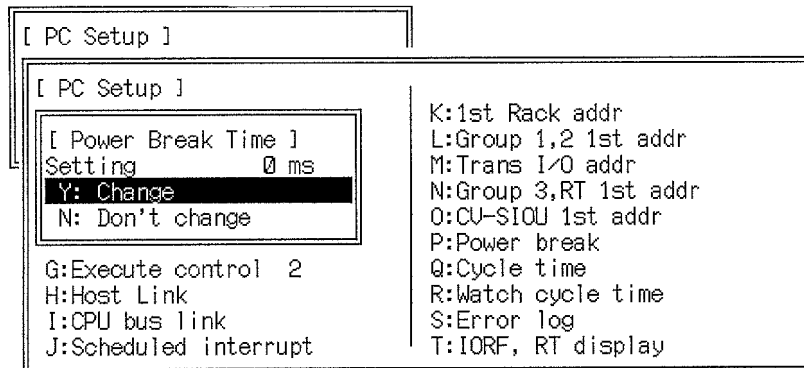

Cycle Time

Specify whether the cycle time is to be maintained at a consistent minimum time or is to be allowed to vary. If you specify a constant cycle, specify the minimum cycle time between 1 and 32,000 ms. The current setting is displayed in parentheses.

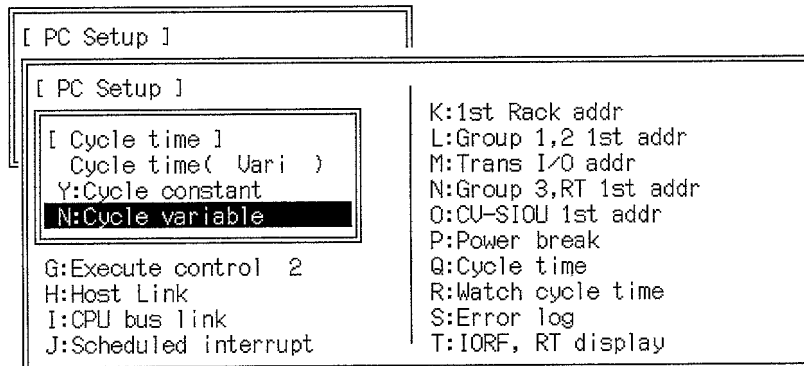

Cycle Time Monitoring Time Specify the maximum allowable cycle time between 10 and 32,000 ms. An error will be generated if the cycle time exceeds the value set here. The current setting is displayed.

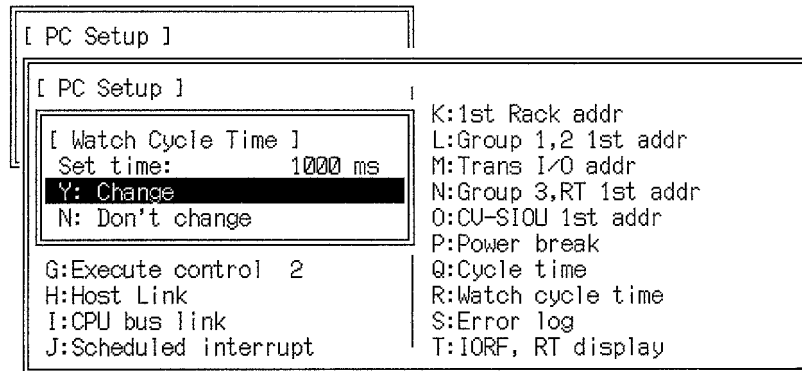

Error Log Area

The number of records kept in the error log and the location that they are kept in memory can be specified. The current settings are displayed first.

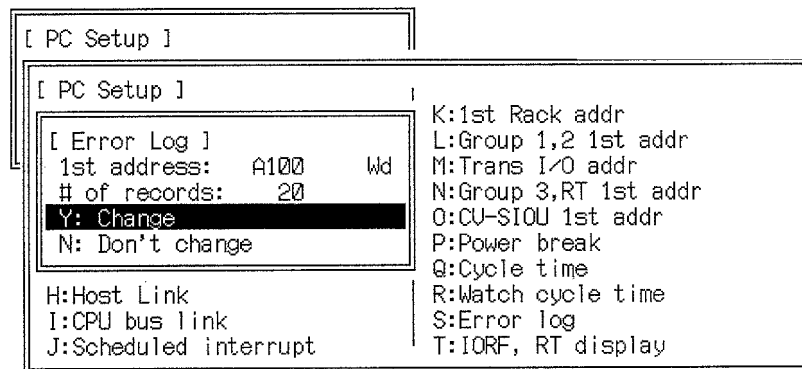

To change the settings, select "Y:Change" and specify the address of the first word in the error log and the number of records to be maintained. Be sure that the error log does not overlap words used for some other purpose.

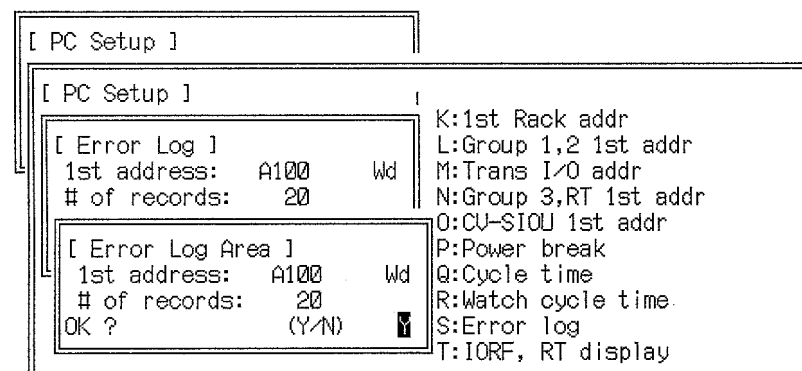

Up to 2,047 records can be maintained. If too many records are set and the boundary of a data area is exceeded, the default settings will be used. The following keys can be used to designate the data area of the first word:

- F5 Key:** DM Area
- F6 Key:** EM Area **F7 Key:** EM bank (use after the F6 Key)
- F1 Key:** Auxiliary Area

When finished, move the cursor to the confirmation area and press the Enter Key.

Display Mode at Startup

Specify the display mode that will be in effect for I/O Interface Units and SYSMAC BUS/2 Remote I/O Slave Units when power is turned on. The current setting is displayed in parentheses.

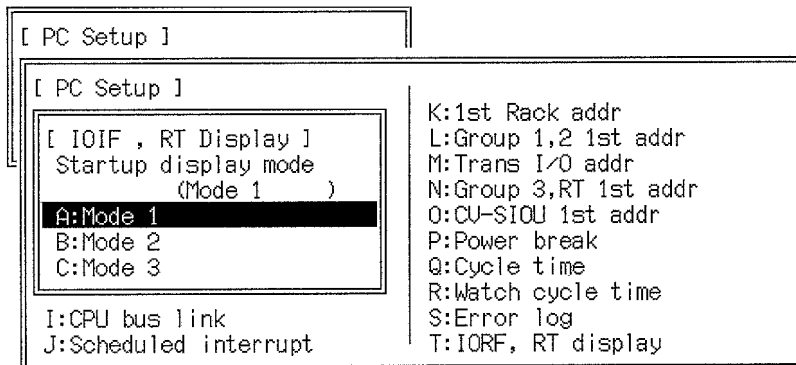

Display Modes

Mode	Display
1	Shows the first word allocated on the Rack.
2	Shows various information depending on the Unit. Refer to the <i>CV500/CV1000 Installation Guide</i> or <i>SYSMAC BUS/2 Remote I/O System Manual</i> for details.
3	Shows displays generated from the PC program with the I/O DISPLAY instruction (IODP(189)).

7-2-2 Saving the PC Setup

The following procedure can be used to save the PC Setup from the work disk to a data disk or the hard disk.

- 1, 2, 3...**
1. Select "S:Save PC settings" from the first PC Setup menu.
 2. If a data disk is being used, place a disk in the disk drive.
 3. Designate the drive and file name into which to save the PC Setup. The file name may be up to eight characters long.
 4. Input a heading for the file if desired. The heading can be up to 30 characters long.

The first PC Setup menu will return after the file has been saved.

7-2-3 Retrieving the PC Setup

The following procedure can be used to retrieve the PC Setup from a data disk or the hard disk to the work disk.

- 1, 2, 3...**
1. Select "R:Retrieve PC settings" from the first PC Setup menu.
 2. If a data disk is being used, place the proper disk in the disk drive.
 3. Input the drive and the name of the file to be retrieved. The End Key or Ctrl+M can be pressed to select the file name from a list of files on the specified disk.

The first PC Setup menu will return after the file has been retrieved.

7-2-4 Clearing the PC Setup

The following procedure can be used to return the PC Setup on the work disk to the initial default values.

- 1, 2, 3... 1. Select "C:Clear PC settings" from the first PC Setup menu.
 2. Input the Y and Enter Keys to return all the parameters in the PC Setup to their original default values.
- Input the N and Enter Keys to cancel the operation.

The first PC Setup menu will return after the PC Setup has been initialized or the operation has been canceled.

7-3 Customization

The Customization menu can be used to record or delete HIS programs, to change function codes for ladder-diagram instructions, to change data the abbreviations (prefixes) used for data areas, or to create custom data areas.

The following menu will appear when "Z:Customize" is selected from the main offline menu. These operations are described in the following subsections.

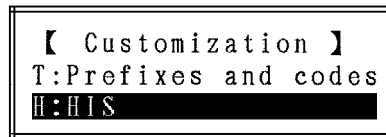

7-3-1 HIS Programs

The following menu will appear if "H:HIS" is selected from the Customization menu. This menu allows you to record or delete HIS programs.

Note Refer to documentation provided with your HIS program for details on HIS programs.



Recording HIS Programs

This operation can be used to register a HIS program for that HIS instructions can be used in the user programs.

- 1, 2, 3... 1. Select "R:Record program" from the menu. A stickup will appear requesting input of the file name. If a HIS program is currently recorded, the name will appear as the default (PIDPROG.HIS in the following display).

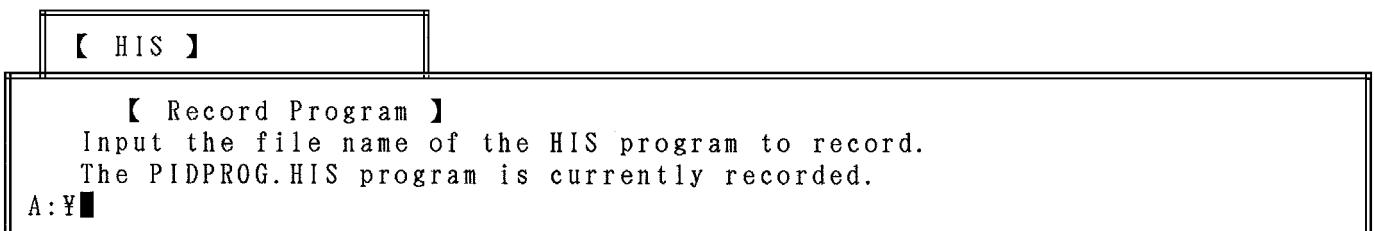

2. Input the name of the file containing the HIS program and press the Enter Key. If a HIS program is not currently recorded, the HIS program will be re-

recorded and HIS instructions can be used. If a HIS program is currently recorded, the following confirmation display will appear.

```

【 HIS 】

I 【 Record Program 】
T The PIDPROG.HIS program is currently recorded.
A:Y Overwrite it ? (Y/N) █
    
```

3. Input the Y and Enter Keys to overwrite the current HIS program with the new one.
or Input the N and Enter Key to cancel the operation.

Note Refer to documentation provided with your HIS program for details on HIS programs file names

Deleting HIS Programs

This operation can be used to delete the HIS program currently registered for used with HIS instructions. You will not be able to use HIS instructions in the user program after executing this operation until a new HIS program is recorded.

- 1, 2, 3... 1. Select "D:Delete program" from the menu. A stickup will appear showing the name of the currently recorded program and asking for confirmation of the deletion. If a HIS program name is not displayed, there is not HIS program currently recorded.

```

【 HIS 】

【 Delete Program 】
The PIDPROG.HIS program is currently recorded.
Delete it? (Y/N) █
    
```

2. Input the Y and Enter Keys to delete the current HIS program.
or Input the N and Enter Key to cancel the operation.

7-3-2 Customizing Function Codes and Data Areas

The PC can be customized to change the function codes for ladder-diagram instruction, the abbreviations (prefixes) used for data areas, or the boundaries of the data areas and create smaller areas.

Note The customized settings will not be effective unless they are transferred to the PC using the online transfer operation.

Customize Menu

The following menu will appear when "T:Prefixes and codes" is selected from the Customize menu. The basic application of each operation is described in the following table.

```

【 Prefixes and codes 】
S:Save custom data
R:Retrieve custom data
F:Chge FUN code
E:Chge data area abbr
G:Word grouping
    
```

Operation	Application
Chge data area abbr	Changes the prefixes for data areas.
Chge FUN code	Changes the function codes of instructions.
Retrieve custom data	Retrieves the customized settings from a data disk or the hard disk to the work disk.
Save custom data	Saves the customized settings from the work disk to a data disk or the hard disk.
Word grouping	Breaks words in part of the CIO Area into custom data areas with area prefixes.

Changing Function Codes

To change function codes, select "F:Chge FUN code." The following display will appear.

Inst	Cod	Inst	Cod	Inst	Cod	Inst	Cod	Inst	Cod
NOP	000	RSET	017	MOVB	042	SRD	069	MLBL	086
END	001	CMP	020	MOVD	043	ADD	070	DUBL	087
IL	002	CMPL	021	DIST	044	SUB	071	INC	090
ILC	003	BCMP	022	COLL	045	MUL	072	DEC	091
JMP	004	TCMP	023	SFT	050	DIU	073	INCB	092
JME	005	MCMP	024	SFTR	051	ADDL	074	DECB	093
FAL	006	EQU	025	ASFT	052	SLBL	075	INCL	094
FALS	007	MOU	030	WSFT	053	MULL	076	DECL	095
STEP	008	MUN	031	ASL	060	DIVL	077	INBL	096
SNXT	009	MOUL	032	ASR	061	STC	078	DCBL	097
NOT	010	MUNL	033	ROL	062	CLC	079	BIN	100
KEEP	011	XCHG	034	ROR	063	ADB	080	BCD	101
CNTR	012	XCGL	035	ASLL	064	SBB	081	BINL	102
DIFU	013	MOUR	036	ASRL	065	MLB	082	BCDL	103
DIFD	014	MOUQ	037	ROLL	066	DUB	083	NEG	104
TIMH	015	XFER	040	RORL	067	ADBL	084	NEGL	105
SET	016	BSET	041	SLD	068	SBBL	085	SIGN	106

Press the F2 Key to enable inputting new function codes and then move the cursor to the each instruction for which a new function code is desired, input the new code, and then press the Enter Key. All function codes must be three digits long and the same function code cannot be assigned to more than one instructions. To access all of the instructions, use the PgUp and PgDn Keys.

When you have finished, press the F10 Key and then press the Enter Key to confirm. The new function codes will be checked to be sure the same code has not been used twice.

If the check finds no mistakes, press the Enter Key to return to the Customize menu. If an error display appears, press the Enter Key to return to the input display for function codes and correct the mistake.

Changing Data Area Prefixes

To change the prefixes used to identify data area and I/O bits, select "E:Change data area abbr" and the following display will appear showing the current prefixes. Select the desired areas and input the new prefixes. Prefixes for the TR Area, Step Area, Transition Area, and Action Area are two character long. Prefixes for all other areas and for I/O bits are one character long.

When finished, move the cursor to the confirmation area and press the Enter Key. If the same prefix is used for more than one area, an error message will appear and you will have to redesignate the prefix.

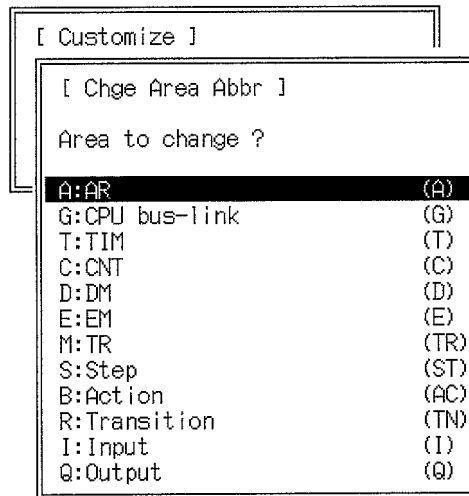

Creating Data Areas

The CIO Area from CIO 0000 to CIO 2555 can be broken up into up to 18 custom data areas with area prefixes. To create custom data area, select "G:Word Grouping." The following display will appear.

Note Once custom data areas have been set, the words and bits in them must always be addressed using the assigned prefixes.

Cod	Abbr	Range	Cod	Abbr	Range
1	█	to Wd	10		to Wd
2		to Wd	11		to Wd
3		to Wd	12		to Wd
4		to Wd	13		to Wd
5		to Wd	14		to Wd
6		to Wd	15		to Wd
7		to Wd	16		to Wd
8		to Wd	17		to Wd
9		to Wd	18		to Wd

Press the F2 Key to enable inputting and then specify the abbreviation (prefix) and word range for each custom data area. The prefixes can be only one character and cannot be the same as prefixes used for other data areas.

Custom areas must be set in order beginning from No. 1 on the display and must be set so that words do not overlap between the areas. The smaller address in each range must be specified first.

The Ins Key can be pressed to open up the current line and move all setting down one line. The Del Key can be pressed to delete the data at the current cursor position.

When you have finished setting data areas and prefixes, press the F10 Key and then press the Enter Key to confirm. The settings will be checked for errors. If the check finds no mistakes, press the Enter Key to return to the Customize menu. If an error display appears, press the Enter Key to return to the input display for function codes and correct the mistake. Possible errors are shown in the following table.

Error	Meaning	Correction
Duplicate prefixes	The same prefix has been used for more than one group or is the the same as a prefix for the normal data areas.	Change the prefixes so that each is used only once.
Duplicate ranges	The same words have been placed in two different groups.	Change the group ranges so that no words overlap.
Range error	The upper limit of the range is specified first.	Specify the smaller address first.

Saving Customized Settings

The following procedure can be used to save the customized settings from the work disk to a data disk or the hard disk.

- 1, 2, 3...**
1. Select "S:Save custom data" from the Customize menu.
 2. If a data disk is being used, place a disk in the disk drive.
 3. Designate the drive and file name into which to save the customized settings. The file name may be up to eight characters long.
 4. Input a heading for the file if desired. The heading can be up to 30 characters long.

The Customize menu will return after the file has been saved.

Retrieving Customized Settings

The following procedure can be used to retrieve the customized settings from a data disk or the hard disk to the work disk.

- 1, 2, 3...**
1. Select "R:Retrieve custom data" from the Customize menu.
 2. If a data disk is being used, place the proper disk in the disk drive.
 3. Input the drive and the name of the file to be retrieved. The End Key can be pressed to select the file name from a list of files on the specified disk.

The Customize menu will return after the file has been retrieved.

Glossary

action	In SFC programs, the individual executable elements in an action block. An action can be defined either as a ladder diagram or as a single bit in memory.
Action Area	A memory area that contains flags that indicate when actions are active.
action block	A collection of all the actions for a single step in an SFC program. Each action is accompanied by its action qualifier, set value, and feedback variable.
action number	A number assigned to an action. Each action has a unique number. These numbers are used to access and to control the status of the action.
action program	A ladder diagram program written to define an action.
action qualifier	A designation made for a action to control when the action is to be executed in respect to the status of the step.
active status	One of the two main statuses that a step can be in. Active status includes pause, halt, and execute status.
active step	A step that is in either pause, halt, or execute status. There can be more than one active step.
address	A number used to identify the location of data or programming instructions in memory or to identify the location of a network or a unit in a network.
advanced instruction	An instruction input with a function code that handles data processing operations within ladder diagrams, as opposed to a basic instruction, which makes up the fundamental portion of a ladder diagram.
allocation	The process by which the PC assigns certain bits or words in memory for various functions. This includes pairing I/O bits to I/O points on Units.
analog	Something that represents or can process a continuous range of values as opposed to values that can be represented in distinct increments. Something that represents or can process values represented in distinct increments is called digital.
Analog I/O Unit	I/O Units that convert I/O between analog and digital values. An Analog Input Unit converts an analog input to a digital value for processing by the PC. An Analog Output Unit converts a digital value to an analog output.
AND	A logic operation whereby the result is true if and only if both premises are true. In ladder-diagram programming the premises are usually ON/OFF states of bits or the logical combination of such states called execution conditions.
AQ	See <i>action qualifier</i> .
area	See <i>data area</i> and <i>memory area</i> .
area prefix	A one or two letter prefix used to identify a memory area in the PC. All memory areas except the CIO area require prefixes to identify addresses in them.
ASCII	Short for American Standard Code for Information Interchange. ASCII is used to code characters for output to printers and other external devices.

Glossary

asynchronous execution	Execution of programs and servicing operations in which program execution and servicing are not synchronized with each other.
Auxiliary Area	A PC data area allocated to flags and control bits.
auxiliary bit	A bit in the Auxiliary Area.
back-up	A copy made of existing data to ensure that the data will not be lost even if the original data is corrupted or erased.
bank	One of multiple sections of a storage area for data or settings. The EM Area is divided into banks each of which is accessed using the same addresses, but different bank numbers.
BASIC	A common programming language. BASIC Units are programmed in BASIC.
basic instruction	A fundamental instruction used in a ladder diagram. See <i>advanced instruction</i> .
Basic Rack	Any of the following Racks: CPU Rack, Expansion CPU Rack, or Expansion I/O Rack.
BASIC Unit	A CPU Bus Unit used to run programs in BASIC.
baud rate	The data transmission speed between two devices in a system measured in bits per second.
BCD	Short for binary-coded decimal.
binary	A number system where all numbers are expressed in base 2, i.e., numbers are written using only 0's and 1's. Each group of four binary bits is equivalent to one hexadecimal digit. Binary data in memory is thus often expressed in hexadecimal for convenience.
binary-coded decimal	A system used to represent numbers so that every four binary bits is numerically equivalent to one decimal digit.
bit	The smallest piece of information that can be represented on a computer. A bit has the value of either zero or one, corresponding to the electrical signals ON and OFF. A bit represents one binary digit. Some bits at particular addresses are allocated to special purposes, such as holding the status of input from external devices, while other bits are available for general use in programming.
bit address	The location in memory where a bit of data is stored. A bit address specifies the data area and word that is being addressed as well as the number of the bit within the word.
bit number	A number that indicates the location of a bit within a word. Bit 00 is the rightmost (least-significant) bit; bit 15 is the leftmost (most-significant) bit.
block	See <i>logic block</i> and <i>instruction block</i> .
block comment	A comment placed in a ladder diagrams that provides user information on an instruction block.
branching	In SFC programs, a means of controlling program flow so that one step leads to two or more steps. See <i>conditional branch</i> and <i>parallel branch</i> .
buffer	A temporary storage space for data in a computerized device.

building-block PC	A PC that is constructed from individual components, or “building blocks.” With building-block PCs, there is no one Unit that is independently identifiable as a PC. The PC is rather a functional assembly of Units.
bus	A communications path used to pass data between any of the Units connected to it.
bus bar	The line leading down the left and sometimes right side of a ladder diagram. Instruction execution proceeds down the bus bar, which is the starting point for all instruction lines.
bus link	A data link that passed data between two Units across a bus.
byte	A unit of data equivalent to 8 bits, i.e., half a word.
central processing unit	A device that is capable of storing programs and data, and executing the instructions contained in the programs. In a PC System, the central processing unit executes the program, processes I/O signals, communicates with external devices, etc.
channel	See <i>word</i> .
character code	A numeric (usually binary) code used to represent an alphanumeric character.
checksum	A sum transmitted with a data pack in communications. The checksum can be recalculated from the received data to confirm that the data in the transmission has not been corrupted.
CIO Area	A memory area used to control I/O and to store and manipulate data. CIO Area addresses do not require prefixes.
common (link) parameter table	A table of settings in a SYSMAC LINK System that specifies what words are to be used in the data links for all PCs in the SYSMAC LINK System. See <i>refresh parameter table</i> .
common data	Data that is stored in a memory of a PC and which is shared by other PCs in the same the same system. Each PC has a specified section(s) of the area allocated to it. Each PC writes to the section(s) allocated to it and reads the sections allocated to the other PCs with which it shares the common data.
Completion Flag	A flag used with a timer or counter that turns ON when the timer has timed out or the counter has reached its set value.
condition	A symbol placed on an instruction line to indicate an instruction that controls the execution condition for the terminal instruction. Each condition is assigned a bit in memory that determines its status. The status of the bit assigned to each condition determines the next execution condition. Conditions correspond to LOAD, LOAD NOT, AND, AND NOT, OR, or OR NOT instructions.
conditional branch	A branch in an SFC program where one step is connected to multiple steps but the active status can be transferred to only one step at a time.
conditional join	In an SFC program, a location where multiple steps coming from the same conditional branch return to a single step.
constant	An input for an operand in which the actual numeric value is specified. Constants can be input for certain operands in place of memory area addresses. Some operands must be input as constants.

continued instruction line	An automatic process on a Programming Device whereby a single instruction is split in two to allow it to fit on the display. The continuation of the instruction line is indicated by two solid boxes, one at the end of the first line and one at the beginning of the second line, and the two resulting lines are treated as a single instruction line.
control bit	A bit in a memory area that is set either through the program or via a Programming Device to achieve a specific purpose, e.g., a Restart Bit is turned ON and OFF to restart a Unit.
control signal	A signal sent from the PC to effect the operation of the controlled system.
Control System	All of the hardware and software components used to control other devices. A Control System includes the PC System, the PC programs, and all I/O devices that are used to control or obtain feedback from the controlled system.
controlled system	The devices that are being controlled by a PC System.
count pulse	The signal counted by a counter.
counter	A dedicated group of digits or words in memory used to count the number of times a specific process has occurred, or a location in memory accessed through a TC bit and used to count the number of times the status of a bit or an execution condition has changed from OFF to ON.
CPU	See <i>central processing unit</i> .
CPU Bus Unit	A special Unit used with CV-series PCs that mounts to the CPU bus. This connection to the CPU bus enables special data links, data transfers, and processing.
CPU Rack	The main Rack in a building-block PC, the CPU Rack contains the CPU, a Power Supply, and other Units. The CPU Rack, along with the Expansion CPU Rack, provides both an I/O bus and a CPU bus.
cross-reference	An operation that searches the program for usage of a specific data area bit or word to see where and how the bit or word is being used. Used during program changes and debugging.
C-series PC	Any of the following PCs: C2000H, C1000H, C500, C200H, C40H, C28H, C20H, C60K, C60P, C40K, C40P, C28K, C28P, C20K, C20P, C120, or C20.
custom data area	A data area defined by the user within the CIO Area. Custom data areas can be set from the CVSS and certain other Programming Devices.
CV Support Software	A programming package run on an IBM PC/AT or compatible to serve as a Programming Device for CV-series PCs.
CV-mode	A form of communications useable only with CV-series PCs. See <i>C-mode</i> .
CV-series PC	Any of the following PCs: CV500, CV1000, CV2000, or CVM1
CVSS	See <i>CV Support Software</i> .
cycle	One unit of processing performed by the CPU, including SFC/ladder program execution, peripheral servicing, I/O refreshing, etc. The cycle is called the scan with C-series PCs.

cycle time	The time required to complete one cycle of CPU processing.
cyclic interrupt	See <i>scheduled interrupt</i> .
data area	An area in the PC's memory that is designed to hold a specific type of data.
data area boundary	The highest address available within a data area. When designating an operand that requires multiple words, it is necessary to ensure that the highest address in the data area is not exceeded.
data disk	A disk that is used to store user data.
data length	In communications, the number of bits that is to be treated as one unit in data transmissions.
data link	An automatic data transmission operation that allows PCs or Units within PC to pass data back and forth via common data areas.
data link area	A common data area established through a data link.
data link table	A table of settings kept in memory that specifies what words are to be part of a data link for all PCs involved in the link.
data register	A storage location in memory used to hold data. In CV-series PCs, data registers are used with or without index registers to hold data used in indirect addressing.
data trace	A process in which changes in the contents of specific memory locations are recorded during program execution.
data transfer	Moving data from one memory location to another, either within the same device or between different devices connected via a communications line or network.
debug	A process by which a draft program is corrected until it operates as intended. Debugging includes both the removal of syntax errors, as well as the fine-tuning of timing and coordination of control operations.
DEBUG mode	A mode of PC operation which enables basic debugging of user programs.
decimal	A number system where numbers are expressed to the base 10. In a PC all data is ultimately stored in binary form, four binary bits are often used to represent one decimal digit, via a system called binary-coded decimal.
decrement	Decreasing a numeric value, usually by 1.
default	A value automatically set by the PC when the user does not specifically set another value. Many devices will assume such default conditions upon the application of power.
definer	A number used as an operand for an instruction but that serves to define the instruction itself, rather than the data on which the instruction is to operate. Definers include jump numbers, subroutine numbers, etc.
destination	The location where an instruction places the data on which it is operating, as opposed to the location from which data is taken for use in the instruction. The location from which data is taken is called the source.
differentiated instruction	An instruction that is executed only once each time its execution condition goes from OFF to ON. Non-differentiated instructions are executed for each scan as long as the execution condition stays ON.

differentiation instruction	An instruction used to ensure that the operand bit is never turned ON for more than one scan after the execution condition goes either from OFF to ON for a Differentiate Up instruction or from ON to OFF for a Differentiate Down instruction.
digit	A unit of storage in memory that consists of four bits.
DIP switch	Dual in-line package switch, an array of pins in a signal package that is mounted to a circuit board and is used to set operating parameters.
distributed control	A automation concept in which control of each portion of an automated system is located near the devices actually being controlled, i.e., control is decentralized and 'distributed' over the system. Distributed control is a concept basic to PC Systems.
DM Area	A data area used to hold only word data. Words in the DM area cannot be accessed bit by bit.
DM word	A word in the DM Area.
downloading	The process of transferring a program or data from a higher-level or host computer to a lower-level or slave computer. If a Programming Device is involved, the Programming Device is considered the host computer.
DR	See <i>data register</i> .
dummy step	A step in an SFC program that contains no actions, such as one used to transfer execution to a subroutine.
EEPROM	Electrically erasable programmable read-only memory; a type of ROM in which stored data can be erased and reprogrammed. This is accomplished using a special control lead connected to the EEPROM chip and can be done without having to remove the EEPROM chip from the device in which it is mounted.
electrical noise	Random variations of one or more electrical characteristics such as voltage, current, and data, which might interfere with the normal operation of a device.
EM Area	Extended Data Memory Area; an area that can be optionally added to certain PCs to enable greater data storage. Functionally, the EM Area operates like the DM Area. Area addresses are prefixed with E and only words can be accessed. The EM Area is separated into multiple banks.
entry step	A step in SFC programming that begins a subchart or interrupt program.
entry terminal	A triangular symbol in SFC programming that comes before the entry step in a subchart or interrupt program.
EPROM	Erasable programmable read-only memory; a type of ROM in which stored data can be erased, by ultraviolet light or other means, and reprogrammed.
error code	A numeric code generated to indicate that an error exists, and something about the nature of the error. Some error codes are generated by the system; others are defined in the program by the operator.
Error Log Area	An area in System DM that is used to store records indicating the time and nature of errors that have occurred in the system.
even parity	A communication setting that adjusts the number of ON bits so that it is always even. See <i>parity</i> .

event processing	Processing that is performed in response to an event, e.g., an interrupt signal.
execution condition	The ON or OFF status under which an instruction is executed. The execution condition is determined by the logical combination of conditions on the same instruction line and up to the instruction currently being executed.
execution cycle	The cycle used to execute all processes required by the CPU, including program execution, I/O refreshing, peripheral servicing, etc.
execution time	The time required for the CPU to execute either an individual instruction or an entire program.
Expansion CPU Rack	A Rack connected to the CPU Rack to increase the virtual size of the CPU Rack. Units that may be mounted to the CPU Backplane may also be mounted to the Expansion CPU Backplane.
Expansion I/O Rack	A Rack used to increase the I/O capacity of a PC. In CV-Series PC, either one Expansion I/O Rack can be connected directly to the CPU or Expansion CPU Rack or multiple Expansion I/O Racks can be connected by using an I/O Control and I/O Interface Units.
FA	Factory automation.
factory computer	A general-purpose computer, usually quite similar to a business computer, that is used in automated factory control.
FAL error	An error generated from the user program by execution of an FAL(006) instruction.
FALS error	An error generated from the user program by execution of an FALS(007) instruction or an error generated by the system.
FAT	File Allocation Table. This is an area of a floppy or hard disk which contains information about the location of the files on the disk.
fatal error	An error that stops PC operation and requires correction before operation can continue.
fatal SFC error	An error in SFC programming that makes further program execution impossible.
FCS	See <i>frame checksum</i> .
feedback variable	One of the input fields in an action block in a SFC program. Memory area addresses can be input for feedback variables as desired by the user, but do not affect operation in any way.
file directory	A list of the files on a floppy or hard disk.
filename extension	The portion of a filename after the period. The extension can be no longer than 3 characters. It is usually used to indicate the type of the file (e.g. <code>BAS</code> indicates files containing BASIC programs, and <code>DAT</code> indicates files containing data).
FINS	See <i>CV-mode</i> .
flag	A dedicated bit in memory that is set by the system to indicate some type of operating status. Some flags, such as the carry flag, can also be set by the operator or via the program.

force reset	The process of forcibly turning OFF a bit via a programming device. Bits are usually turned OFF as a result of program execution.
force set	The process of forcibly turning ON a bit via a programming device. Bits are usually turned ON as a result of program execution.
forced status	The status of bits that have been force reset or force set.
frame checksum	The results of exclusive ORing all data within a specified calculation range. The frame checksum can be calculated on both the sending and receiving end of a data transfer to confirm that data was transmitted correctly.
function code	A two-digit number used to input an instruction into the PC.
FV	See <i>feedback variable</i> .
GPC	An acronym for Graphic Programming Console.
Graphic Programming Console	A programming device with advanced programming and debugging capabilities to facilitate PC operation. A Graphic Programming Console is provided with a large display onto which ladder-diagram programs can be written directly in ladder-diagram symbols for input into the PC without conversion to mnemonic form.
guidance display	Messages that appear on-screen to aid the operator.
halt	One of the three active statuses of steps in an SFC program. Steps in halt status are not executed.
hardware error	An error originating in the hardware structure (electronic components) of the PC, as opposed to a software error, which originates in software (i.e., programs).
hexadecimal	A number system where all numbers are expressed to the base 16. In a PC all data is ultimately stored in binary form, however, displays and inputs on Programming Devices are often expressed in hexadecimal to simplify operation. Each group of four binary bits is numerically equivalent to one hexadecimal digit.
hold bit	A bit in memory designated to maintain status when the PC's operating mode is changed or power is turned off and then back on.
hold Rack	A Rack designated to maintain output status when the PC's operating mode is changed or power is turned off and then back on.
holding area	Words in memory designated to maintain status when the PC's operating mode is changed or power is turned off and then back on.
host computer	A computer that is used to transfer data to or receive data from a PC in a Host Link system. The host computer is used for data management and overall system control. Host computers are generally small personal or business computers.
host interface	An interface that allows communications with a host computer.
Host Link System	A system with one or more host computers connected to one or more PCs via Host Link Units or host interfaces so that the host computer can be used to transfer data to and from the PC(s). Host Link Systems enable centralized management and control of PC Systems.

Host Link Unit	An interface used to connect a C-series PC to a host computer in a Host Link System.
I/O allocation	The process by which the PC assigns certain bits in memory for various functions. This includes pairing I/O bits to I/O points on Units.
I/O bit	A bit in memory used to hold I/O status. Input bits reflect the status of input terminals; output bits hold the status for output terminals.
I/O Block	Either an Input Block or an Output Block. I/O Blocks provide mounting positions for replaceable relays.
I/O capacity	The number of inputs and outputs that a PC is able to handle. This number ranges from around one hundred for smaller PCs to two thousand for the largest ones.
I/O comment	A comment in a program that is related to the use of operands.
I/O Control Unit	A Unit mounted to the CPU Rack to monitor and control I/O points on Expansion CPU Racks or Expansion I/O Racks.
I/O delay	The delay in time from when a signal is sent to an output to when the status of the output is actually in effect or the delay in time from when the status of an input changes until the signal indicating the change in the status is received.
I/O device	A device connected to the I/O terminals on I/O Units, Special I/O Units, etc. I/O devices may be either part of the Control System, if they function to help control other devices, or they may be part of the controlled system.
I/O Interface Unit	A Unit mounted to an Expansion CPU Rack or Expansion I/O Rack to interface the Rack to the CPU Rack.
I/O interrupt	An interrupt generated by a signal from I/O.
I/O interrupt entry terminal	An entry terminal for an I/O interrupt program.
I/O interrupt return terminal	A return terminal for an I/O interrupt program.
I/O name	A name assigned to a bit or word used in a program that can be used to input the bit or word, or can be displayed to indicate the bit or word on a monitor.
I/O point	The place at which an input signal enters the PC System, or at which an output signal leaves the PC System. In physical terms, I/O points correspond to terminals or connector pins on a Unit; in terms of programming, an I/O points correspond to I/O bits in the IR area.
I/O refreshing	The process of updating output status sent to external devices so that it agrees with the status of output bits held in memory and of updating input bits in memory so that they agree with the status of inputs from external devices.
I/O response time	The time required for an output signal to be sent from the PC in response to an input signal received from an external device.
I/O table	A table created within the memory of the PC that lists the I/O words allocated to each Unit in the PC System. The I/O table can be created by, or modified from, a Programming Device.
I/O Terminal	A Remote I/O Unit connected in a Wired Remote I/O System to provide a limited number of I/O points at one location. There are several types of I/O Terminals.

I/O Unit	The most basic type of Unit mounted to a Backplane. I/O Units include Input Units and Output Units, each of which is available in a range of specifications. I/O Units do not include Special I/O Units, Link Units, etc.
I/O verification error	A error generated by a disagreement between the Units registered in the I/O table and the Units actually mounted to the PC.
I/O word	A word in the CIO area that is allocated to a Unit in the PC System and is used to hold I/O status for that Unit.
IBM PC/AT or compatible	A computer that has similar architecture to, that is logically compatible with, and that can run software designed for an IBM PC/AT computer.
immediate refreshing	A form of I/O refreshing that is executed by certain types of instruction when the instruction is executed to ensure that the most current input status is used for an operand or to ensure that an output is effective immediately.
inactive status	The status of a step in an SFC program in which the actions within that step are not executed, with the exception of any actions with action qualifiers that extend execution beyond active status. Inactive status also enables a step to go into active status provided other conditions are met.
increment	Increasing a numeric value, usually by 1.
index register	A data storage location used with or without a data register in indirect addressing.
initial step	A step that automatically goes to active status when SFC program execution is begun.
initialize	Part of the startup process whereby some memory areas are cleared, system setup is checked, and default values are set.
input	The signal coming from an external device into the PC. The term input is often used abstractly or collectively to refer to incoming signals.
input bit	A bit in the CIO area that is allocated to hold the status of an input.
Input Block	A Unit used in combination with a Remote Interface to create an I/O Terminal. An Input Block provides mounting positions for replaceable relays. Each relay can be selected according to specific input requirements.
input device	An external device that sends signals into the PC System.
input point	The point at which an input enters the PC System. Input points correspond physically to terminals or connector pins.
input signal	A change in the status of a connection entering the PC. Generally an input signal is said to exist when, for example, a connection point goes from low to high voltage or from a nonconductive to a conductive state.
Input Terminal	An I/O Terminal that provides input points.
insert	The process by which a program section held in a peripheral device is saved in PC memory at the location just prior to the last program section that was saved.
instruction	A direction given in the program that tells the PC of the action to be carried out, and the data to be used in carrying out the action. Instructions can be used to

	simply turn a bit ON or OFF, or they can perform much more complex actions, such as converting and/or transferring large blocks of data.
instruction block	A group of instructions that is logically related in a ladder-diagram program. A logic block includes all of the instruction lines that interconnect with each other from one or more line connecting to the left bus bar to one or more right-hand instructions connecting to the right bus bar.
instruction execution time	The time required to execute an instruction. The execution time for any one instruction can vary with the execution conditions for the instruction and the operands used in it.
instruction line	A group of conditions that lie together on the same horizontal line of a ladder diagram. Instruction lines can branch apart or join together to form instruction blocks. Also called a rung.
interface	An interface is the conceptual boundary between systems or devices and usually involves changes in the way the communicated data is represented. Interface devices such as NSBs perform operations like changing the coding, format, or speed of the data.
intermediate code	A coding form for programs that is partway between the user-written code and machine language code.
intermediate instruction	An instruction other than one corresponding to a condition that appears in the middle of an instruction line and requires at least one more instruction between it and the right bus bar.
interrupt (signal)	A signal that stops normal program execution and causes a subroutine to be run or other processing to take place.
Interrupt Input Unit	A Rack-mounting Unit used to input external interrupts into a PC System.
interrupt program	A program that is executed in response to an interrupt.
inverse condition	See <i>normally closed condition</i> .
IOIF	An acronym for I/O Interface Unit.
IOM (Area)	A collective memory area containing all of the memory areas that can be accessed by bit, including timer and counter Completion Flags. The IOM Area includes all memory area memory addresses between 0000 and 0FFF.
JIS	An acronym for Japanese Industrial Standards.
joining	A process used in SFC programs to return execution from steps on multiple branch lines to a single step.
jump	A type of programming where execution moves directly from one point in a program to another, without sequentially executing any instructions in between. Jumps in ladder diagrams are usually conditional on an execution condition; jumps in SFC programs are conditional on the step status and transition condition status before the jump.
jump number	A definer used with a jump that defines the points from and to which a jump is to be made.
Kanji character	A character in one of the three sets of characters used to write the Japanese language

keyed retrieval	A method for searching for text that allows an item to be found though inputting only a portion of it. For example, I/O comments can be found by inputting only a portion from the beginning of the text string of which the I/O comment exists.
ladder diagram (program)	A form of program arising out of relay-based control systems that uses circuit-type diagrams to represent the logic flow of programming instructions. The appearance of the program is similar to a ladder, and thus the name.
ladder diagram symbol	A symbol used in drawing a ladder-diagram program.
leading zero	One of one or more consecutive zeros in the leftmost digits of an address or numeric value.
least-significant (bit/word)	See <i>rightmost (bit/word)</i> .
LED	Acronym for light-emitting diode; a device used as for indicators or displays.
leftmost (bit/word)	The highest numbered bits of a group of bits, generally of an entire word, or the highest numbered words of a group of words. These bits/words are often called most-significant bits/words.
link	A hardware or software connection formed between two Units. "Link" can refer either to a part of the physical connection between two Units or a software connection created to data existing at another location (i.e., data links).
Link Area	A data area that is designed for use in data links.
link parameter table	See <i>common link parameter table</i> .
Link System	A system used to connect remote I/O or to connect multiple PCs in a network. Link Systems include the following: SYSMAC BUS Remote I/O Systems, SYSMAC BUS/2 Remote I/O Systems, SYSMAC LINK Systems, Host Link Systems, and SYSMAC NET Link Systems.
Link Unit	Any of the Units used to connect a PC to a Link System. These include Remote I/O Units, SYSMAC LINK Units, and SYSMAC NET Link Units.
load	The processes of copying data either from an external device or from a storage area to an active portion of the system such as a display buffer. Also, an output device connected to the PC is called a load.
local network table	A table that specifies all of the networks that a PC belongs to and the unit numbers of the Units connecting the PC to each of these networks.
logic block	A group of instructions that is logically related in a ladder-diagram program and that requires logic block instructions to relate it to other instructions or logic blocks.
logic block instruction	An instruction used to locally combine the execution condition resulting from a logic block with a current execution condition. The current execution condition could be the result of a single condition, or of another logic block. AND Load and OR Load are the two logic block instructions.
loop-back	The processes of using an alternate communications path that runs in the reverse direction of the normal communications path to prevent communications from being disabled when communications along the normal path are not possible.

machine code	The binary program code that is actual executed by a CPU.
machine language	A programming language in which the program is written directly into machine code.
main program	All of a program except for subroutine and interrupt programs.
mark trace	A process in which changes in the contents of specific memory locations are recorded during program execution using MARK (174) instructions.
masked bit	A bit whose status has been temporarily made ineffective.
masking	'Covering' an interrupt signal so that the interrupt is not effective until the mask is removed.
Master	Short for Remote I/O Master Unit.
master	In a SYSMAC NET Link System, a Unit specified to manage network communications.
master number	A number assigned to a master in a SYSMAC NET Link System. This number is different from the unit number.
MCR Unit	Magnetic Card Reader Unit.
megabyte	A unit of storage equal to one million bytes.
memory area	Any of the areas in the PC used to hold data or programs.
memory card	A data storage media similar to a floppy disk.
memory switch	A bit or bits in memory that are used to set operating parameters similar to the way a hardware switch would be.
message number	A number assigned to a message generated with the MSG(195) instruction.
mnemonic code	A form of a ladder-diagram program that consists of a sequential list of the instructions without using a ladder diagram.
MONITOR mode	A mode of PC operation in which normal program execution is possible, and which allows modification of data held in memory. Used for monitoring or debugging the PC.
most-significant (bit/word)	See <i>leftmost (bit/word)</i> .
MS-DOS	An operating system in common use on smaller computers.
NC input	An input that is normally closed, i.e., the input signal is considered to be present when the circuit connected to the input opens.
negative delay	A delay set for a data trace in which recording data begins before the trace signal by a specified amount.
nesting	Programming one loop within another loop, programming a call to a subroutine within another subroutine, or programming an IF-ELSE programming section within another IF-ELSE section.
Network Service Board	A device with an interface to connect devices other than PCs to a SYSMAC NET Link System.

Network Service Unit	A Unit that provides two interfaces to connect peripheral devices to a SYSMAC NET Link System.
network support table	Tables of settings used to establish operating parameters for SYSMAC LINK and SYSMAC NET Link Systems.
NO input	An input that is normally open, i.e., the input signal is considered to be present when the circuit connected to the input closes.
node	One of the positions in a LAN. Each node incorporates a device that can communicate with the devices at all of the other nodes. The device at a node is identified by the node number.
node number	A number used to identify a node on a network. The node number of a CV-series PC is called the "unit number" in the PC Setup.
noise interference	Disturbances in signals caused by electrical noise.
nonfatal error	A hardware or software error that produces a warning but does not stop the PC from operating.
non-fatal SFC error	An error in SFC programming that does not make further program execution impossible, but that may be an indication of a problem in programming.
normal condition	See <i>normally open condition</i> .
normally closed condition	A condition that produces an ON execution condition when the bit assigned to it is OFF, and an OFF execution condition when the bit assigned to it is ON.
normally open condition	A condition that produces an ON execution condition when the bit assigned to it is ON, and an OFF execution condition when the bit assigned to it is OFF.
NOT	A logic operation which inverts the status of the operand. For example, AND NOT indicates an AND operation with the opposite of the actual status of the operand bit.
object code	The code that a program is converted to before actual execution. See <i>source code</i> .
octal	A number system where all numbers are expressed in base 8, i.e., numbers are written using only numerals 0 through 7.
odd parity	A communications setting that adjusts the number of ON bits so that it is always odd. See <i>parity</i> .
OFF	The status of an input or output when a signal is said not to be present. The OFF state is generally represented by a low voltage or by non-conductivity, but can be defined as the opposite of either.
OFF delay	The delay between the time when a signal is switched OFF (e.g., by an input device or PC) and the time when the signal reaches a state readable as an OFF signal (i.e., as no signal) by a receiving party (e.g., output device or PC).
offline	The state in which a Programming Device is not functionally connected to the CPU, although it may be connected physically.
offset	A positive or negative value added to a base value such as an address to specify a desired value.

ON	The status of an input or output when a signal is said to be present. The ON state is generally represented by a high voltage or by conductivity, but can be defined as the opposite of either.
ON delay	The delay between the time when an ON signal is initiated (e.g., by an input device or PC) and the time when the signal reaches a state readable as an ON signal by a receiving party (e.g., output device or PC).
online	The state in which a Programming Device is functionally connected to the CPU so that CPU data and programs can be monitored or accessed.
online edit	An edit to a program made from a peripheral device connected to and currently online with a PC in PROGRAM or MONITOR mode. In MONITOR mode, this means that the program is changed while it is actually being executed.
on-line removal	Removing a Rack-mounted Unit for replacement or maintenance during PC operation.
operand	The values designated as the data to be used for an instruction. An operand can be input as a constant expressing the actual numeric value to be used or as an address to express the location in memory of the data to be used.
operand bit	A bit designated as an operand for an instruction.
operand word	A word designated as an operand for an instruction.
operating error	An error that occurs during actual PC operation as opposed to an initialization error, which occurs before actual operations can begin.
optical cable link	In a Wired Remote I/O System, an optical cable connecting two Converting Link Adapters.
optical communications	A communications method in which signals are sent over optical fiber cable to prevent noise interference and increase transmission distance.
Optical I/O Unit	A Unit that is connected in an Optical Remote I/O System to provide 8 I/O points. Optical I/O Units are not mounted to a Rack.
Optical Master	Short for Optical Remote I/O Master Unit.
Optical Slave Rack	A Slave Rack connected through an Optical Remote I/O Slave Unit.
OR	A logic operation whereby the result is true if either of two premises is true, or if both are true. In ladder-diagram programming the premises are usually ON/OFF states of bits or the logical combination of such states called execution conditions.
output	The signal sent from the PC to an external device. The term output is often used abstractly or collectively to refer to outgoing signals.
output bit	A bit in the IR area that is allocated to hold the status to be sent to an output device.
Output Block	A Unit used in combination with a Remote Interface to create an I/O Terminal. An Output Block provides mounting positions for replaceable relays. Each relay can be selected according to specific output requirements.
output device	An external device that receives signals from the PC System.

output point	The point at which an output leaves the PC System. Output points correspond physically to terminals or connector pins.
output signal	A signal being sent to an external device. Generally an output signal is said to exist when, for example, a connection point goes from low to high voltage or from a nonconductive to a conductive state.
Output Terminal	An I/O Terminal that provides output points.
overflow	The state where the capacity of a data storage location has been exceeded.
overwrite	Changing the content of a memory location so that the previous content is lost.
parallel branch	A branch in an SFC program where one step is connection to multiple steps and the active status must be transferred to all of the steps.
parallel join	In an SFC program, a location where multiple steps coming from the same parallel branch return to a single step.
Parameter Area	A part of System DM used to designate various PC operating parameters.
Parameter Backup Area	A part of System DM used to back up the Parameter Area.
parity	Adjustment of the number of ON bits in a word or other unit of data so that the total is always an even number or always an odd number. Parity is generally used to check the accuracy of data after being transmitted by confirming that the number of ON bits is still even or still odd.
parity check	Checking parity to ensure that transmitted data has not been corrupted.
pause	One of the three active statuses of steps in an SFC program. Steps in pause status are not executed.
PC	An acronym for Programmable Controller.
PC configuration	The arrangement and interconnections of the Units that are put together to form a functional PC.
PC System	With building-block PCs, all of the Racks and independent Units connected directly to them up to, but not including the I/O devices. The boundaries of a PC System are the PC and the program in its CPU at the upper end; and the I/O Units, Special I/O Units, Optical I/O Units, Remote Terminals, etc., at the lower end.
PCB	An acronym for printed circuit board.
PC Setup	A group of operating parameters set in the PC from a Programming Device to control PC operation.
Peripheral Device	Devices connected to a PC System to aid in system operation. Peripheral devices include printers, programming devices, external storage media, etc.
peripheral servicing	Processing signals to and from peripheral devices, including refreshing, communications processing, interrupts, etc.
PID Unit	A Unit designed for PID control.
polling	The process whereby a devices consecutively sends signals to other devices in the same network to pass data back and forth, e.g., as in a data link.

positive delay	A delay set for a data trace in which recording data begins after the trace signal by a specified amount.
positive loop	The normal loop used for communications. See <i>negative loop</i> .
power-off interrupt	An interrupt executed when power to the PC is turned off.
power-on interrupt	An interrupt executed when power to the PC is turned on.
present value	The current value registered in a device at any instant during its operation. Present value is abbreviated as PV. The use of this term is generally restricted to timers and counters.
printed circuit board	A board onto which electrical circuits are printed for mounting into a computer or electrical device.
PROGRAM mode	A mode of operation that allows inputting and debugging of programs to be carried out, but that does not permit normal execution of the program.
Programmable Controller	A computerized device that can accept inputs from external devices and generate outputs to external devices according to a program held in memory. Programmable Controllers are used to automate control of external devices. Although single-unit Programmable Controllers are available, building-block Programmable Controllers are constructed from separate components. Such Programmable Controllers are formed only when enough of these separate components are assembled to form a functional assembly, i.e., there is no one individual Unit called a PC.
programmed alarm	An alarm given as a result of execution of an instruction designed to generate the alarm in the program, as opposed to one generated by the system.
programmed error	An error arising as a result of the execution of an instruction designed to generate the error in the program, as opposed to one generated by the system.
programmed message	A message generated as a result of execution of an instruction designed to generate the message in the program, as opposed to one generated by the system.
Programming Console	The simplest form of programming device available for a PC. Programming Consoles are available both as hand-held models and as CPU-mounting models.
Programming Device	A Peripheral Device used to input a program into a PC or to alter or monitor a program already held in the PC. There are dedicated programming devices, such as Programming Consoles, and there are non-dedicated devices, such as a host computer.
PROM	Programmable read-only memory; a type of ROM into which the program or data may be written after manufacture, by a customer, but which is fixed from that time on.
PROM Writer	A peripheral device used to write programs and other data into a ROM for permanent storage and application.
prompt	A message or symbol that appears on a display to request input from the operator.
protocol	The parameters and procedures that are standardized to enable two devices to communicate or to enable a programmer or operator to communicate with a device.

PV	See <i>present value</i> .
Rack	An assembly that forms a functional unit in a Rack PC System. A Rack consists of a Backplane and the Units mounted to it. These Units include the Power Supply, CPU, and I/O Units. Racks include CPU Racks, Expansion I/O Racks, and I/O Racks. The CPU Rack is the Rack with the CPU mounted to it. An Expansion I/O Rack is an additional Rack that holds extra I/O Units. An I/O Rack is used in the C2000H Duplex System, because there is no room for any I/O Units on the CPU Rack in this System.
rack number	A number assigned to a Rack according to the order that it is connected to the CPU Rack, with the CPU Rack generally being rack number 0.
Rack PC	A PC that is composed of Units mounted to one or more Racks. This configuration is the most flexible, and most large PCs are Rack PCs. A Rack PC is the opposite of a Package-type PC, which has all of the basic I/O, storage, and control functions built into a single package.
RAM	Random access memory; a data storage media. RAM will not retain data when power is disconnected.
RAS	An acronym for reliability, assurance, safety.
read-only area	A memory area from which the user can read status but to which data cannot be written.
refresh	The process of updating output status sent to external devices so that it agrees with the status of output bits held in memory and of updating input bits in memory so that they agree with the status of inputs from external devices.
refresh parameter (table)	A table of settings that specifies which words in the data links for a System are to be refreshed for a particular PC. See <i>common link parameter table</i> .
Register Area	A memory area that contains both index registers and data registers.
relay network table	A table of settings that specifies which node in a network must be passed through to reach another network.
relay-based control	The forerunner of PCs. In relay-based control, groups of relays are interconnected to form control circuits. In a PC, these are replaced by programmable circuits.
Remote I/O Master Unit	The Unit in a Remote I/O System through which signals are sent to all other Remote I/O Units. Remote I/O Master Unit is generally abbreviated to Master.
Remote I/O Slave Unit	A Unit mounted to a Backplane to form a Slave Rack. Remote I/O Slave Unit is generally abbreviated to simply "Slave."
Remote I/O Subsystem	A Master and all of the Remote I/O Units connected in series to it.
Remote I/O System	A system in which remote I/O points on Slaves are controlled through one or more Masters mounted to a CPU or Expansion CPU Rack.
Remote I/O Unit	Any of the Units in a Remote I/O System. Remote I/O Units include Masters, Slaves, Optical I/O Units, and I/O Terminals.
remote I/O word	An I/O word allocated to a Unit in a Remote I/O System.

reserved bit	A bit that is not available for user application.
reserved word	A word in memory that is reserved for a special purpose and cannot be accessed by the user.
reset	The process of turning a bit or signal OFF or of changing the present value of a timer or counter to its set value or to zero.
response monitoring time	The time a device will wait for a response to a data transmission before assuming that an error has occurred.
Restart Bit	A bit used to restart a Unit mounted to a PC.
restart continuation	A process which allows memory and program execution status to be maintained so that PC operation can be restarted from the state it was in when operation was stopped by a power interruption.
retrieve	The processes of copying data either from an external device or from a storage area to an active portion of the system such as a display buffer. Also, an output device connected to the PC is called a load.
retry	The process whereby a device will re-transmit data which has resulted in an error message from the receiving device.
return step	A step in SFC programming that ends a subroutine or interrupt program.
return terminal	A triangular symbol in SFC programming that comes after the return step in a subroutine or interrupt program.
reverse video	Displaying characters on a monitor so that the normal colors of the characters and the background are reversed.
right-hand instruction	See <i>terminal instruction</i> .
rightmost (bit/word)	The lowest numbered bits of a group of bits, generally of an entire word, or the lowest numbered words of a group of words. These bits/words are often called least-significant bits/words.
rising edge	The point where a signal actually changes from an OFF to an ON status.
ROM	Read only memory; a type of digital storage that cannot be written to. A ROM chip is manufactured with its program or data already stored in it and can never be changed. However, the program or data can be read as many times as desired.
routing table	Tables of setting that specify what networks a device is a member of and what nodes must be passed through to reach other specific networks. See <i>local network table</i> and <i>relay network table</i> .
RS-232C interface	An industry standard for serial communications.
RS-422 interface	An industry standard for serial communications.
RUN mode	The operating mode used by the PC for normal control operations.
rung	See <i>instruction line</i> .
scan	The process used to execute a ladder-diagram program. The program is examined sequentially from start to finish and each instruction is executed in turn

based on execution conditions. The scan also includes peripheral processing, I/O refreshing, etc. The scan is called the cycle with CV-series PCs.

scan time	The time required for a single scan of a ladder-diagram program.
scheduled interrupt	An interrupt that is automatically generated by the system at a specific time or program location specified by the operator. Scheduled interrupts result in the execution of specific subroutines that can be used for instructions that must be executed repeatedly at a specified interval of time.
screen editor	A program that is used on-screen to edit files.
self diagnosis	A process whereby the system checks its own operation and generates a warning or error if an abnormality is discovered.
sequential function chart	A programming method that allows overall processing to be programmed as a flowchart of steps and detailed processing to be programmed as actions within each step.
series	A wiring method in which Units are wired consecutively in a string. In Link Systems wired through Link Adapters, the Units are still functionally wired in series, even though Units are placed on branch lines.
servicing	The process whereby the PC provides data to or receives data from external devices or remote I/O Units, or otherwise handles data transactions for Link Systems.
set	The process of turning a bit or signal ON.
set value	The value from which a decrementing counter starts counting down or to which an incrementing counter counts up (i.e., the maximum count), or the time from which or for which a timer starts timing. Set value is abbreviated SV.
SFC	An acronym for sequential function chart.
SFC jump	A type of programming where execution moves directly from one step in a program to another step, without sequentially executing the steps in between.
SFC jump entry	The symbol or process used in an SFC program to indicate an SFC jump.
sheet	A unit of programming in an SFC program. There is a limit on the number of steps that can be contained within a single sheet and the types of processes that can take place between sheets.
SIOW	See <i>Special I/O Unit</i> .
Slave	See <i>Remote I/O Slave Unit</i> .
Slave Rack	A Rack containing a Remote I/O Slave Unit and controlled through a Remote I/O Master Unit. Slave Racks are generally located away from the CPU Rack.
software error	An error that originates in a software program.
software protect	A means of protecting data from being changed that uses software as opposed to a physical switch or other hardware setting.
software switch	See <i>memory switch</i> .

Glossary

source code	The code in which a program is written, e.g., ASCII. Source code must be converted to object code before execution.
Special I/O Unit	A Unit that is designed for a specific purpose. Special I/O Units include Position Control Units, High-speed Counter Units, Analog I/O Units, etc.
SRAM	Static random access memory; a data storage media.
step	A basic unit of execution in an SFC program. Steps are used to organize an SFC program by process and control the overall flow of program execution.
Step Area	A memory area that contains a flag that indicates the status of steps in an SFC program.
step timer	A timer used to time execution of actions within a step in an SFC program.
store	The process by which a program section held in a peripheral device is saved in PC memory at the same location from which it was read.
string	A sequence of letters, numbers, and/or symbols stored in memory.
subchart	A section of an SFC program that is executed like a subroutine. See <i>subroutine</i> .
subchart dummy step	A step in an SFC program that is used to call (activate) a subchart.
subchart entry step	A step in SFC programming that begins a subchart.
subchart entry terminal	A triangular symbol in SFC programming that comes before the entry step in a subchart.
subchart return step	A step in SFC programming that ends a subchart.
subchart return terminal	A triangular symbol in SFC programming that comes after the return step in sub-chart.
sub-loop	A line mode used in a Remote I/O System to maintain communications when an error occurs on the positive line.
subroutine	A group of instructions placed separate from the main program and executed only when called from the main program or activated by an interrupt.
subroutine number	A definer used to identify the subroutine that a subroutine call or interrupt activates.
SV	Abbreviation for set value.
synchronous execution	Execution of programs and servicing operations in which program execution and servicing are synchronized so that all servicing operations are executed each time the programs are executed.
syntax	The form of a program statement (as opposed to its meaning). For example, the two statements, <code>LET A=B+B</code> and <code>LET A=B*2</code> use different syntaxes, but have the same meaning.
syntax error	An error in the way in which a program is written. Syntax errors can include 'spelling' mistakes (i.e., a function code that does not exist), mistakes in specifying operands within acceptable parameters (e.g., specifying read-only bits as a

	destination), and mistakes in actual application of instructions (e.g., a call to a subroutine that does not exist).
SYSMAC BUS/2 Remote I/O System	A remote I/O system used to enable placing Slaves at remote locations to extend the applicable range of a PC System.
SYSMAC LINK System	A communications system used to create data links and enable network communications between PCs.
SYSMAC NET Link System	An optical LAN formed from PCs connected through SYSMAC NET Link Units. A SYSMAC NET Link System also normally contains nodes interfacing computers and other peripheral devices. PCs in the SYSMAC NET Link System can pass data back and forth, receive commands from any interfaced computer, and share any interfaced peripheral device.
SYSMAC NET Link Unit	The Unit used to connect PCs to a SYSMAC NET Link System.
system configuration	The arrangement in which Units in a System are connected. This term refers to the conceptual arrangement and wiring together of all the devices needed to comprise the System. In OMRON terminology, system configuration is used to describe the arrangement and connection of the Units comprising a Control System that includes one or more PCs.
System DM	A dedicated portion of the DM area that is used for special purposes in controlling and managing the PC. Includes the Program Version, Parameter Area, Parameter Backup Area, User Program Header, and Error Log Area.
system error	An error generated by the system, as opposed to one resulting from execution of an instruction designed to generate an error.
system error message	An error message generated by the system, as opposed to one resulting from execution of an instruction designed to generate a message.
terminal instruction	An instruction placed on the right side of a ladder diagram that uses the final execution conditions of an instruction line.
terminator	The code comprising an asterisk and a carriage return (* CR) which indicates the end of a block of data in communications between devices. Frames within a multi-frame block are separated by delimiters. Also a Unit in a Link System designated as the last Unit on the communications line.
timer	A location in memory accessed through a TC bit and used to time down from the timer's set value. Timers are turned ON and reset according to their execution conditions.
TR Area	A data area used to store execution conditions so that they can be reloaded later for use with other instructions.
TR bit	A bit in the TR Area.
trace	An operation whereby the program is executed and the resulting data is stored to enable step-by-step analysis and debugging.
trace memory	A memory area used to store the results of trace operations.
transfer	The process of moving data from one location to another within the PC, or between the PC and external devices. When data is transferred, generally a copy

	of the data is sent to the destination, i.e., the content of the source of the transfer is not changed.
transition	A status in a SFC program that determines when active status is transferred from one step to another. Transitions can be defined either as the status of a bit or as an execution condition resulting from a ladder diagram.
Transition Area	A memory area that contains Transition Flags.
Transition Flag	A flag that indicates when a transition is ON or OFF.
transition number	A number assigned to a transition and used to access its Transition Flag.
transmission distance	The distance that a signal can be transmitted.
trigger	A signal used to activate some process, e.g., the execution of a trace operation.
trigger address	An address in the program that defines the beginning point for tracing. The actual beginning point can be altered from the trigger by defining either a positive or negative delay.
UM area	The memory area used to hold the active program, i.e., the program that is being currently executed.
Unit	In OMRON PC terminology, the word Unit is capitalized to indicate any product sold for a PC System. Though most of the names of these products end with the word Unit, not all do, e.g., a Remote Terminal is referred to in a collective sense as a Unit. Context generally makes any limitations of this word clear.
unit address	A number used to control network communications. Unit addresses are computed for Units in various ways, e.g., 10 hex is added to the unit number to determine the unit address for a CPU Bus Unit.
unit number	A number assigned to some Link Units, Special I/O Units, and CPU Bus Units to facilitate identification when assigning words or other operating parameters.
unmasked bit	A bit whose status is effective. See <i>masked bit</i> .
uploading	The process of transferring a program or data from a lower-level or slave computer to a higher-level or host computer. If a Programming Device is involved, the Programming Device is considered the host computer.
vector table	A work file created by CVSS that is used by the software to access ladder programs for editing. The vector table lists the first address of each ladder program block.
verification error	See <i>I/O verification error</i> .
volume label	The name of a volume of storage material (a floppy disk, hard disk, or memory card).
watchdog timer	A timer within the system that ensures that the scan time stays within specified limits. When limits are reached, either warnings are given or PC operation is stopped depending on the particular limit that is reached.
WDT	See <i>watchdog timer</i> .
wildcard	A special character used in a filename or extension to indicate zero or more possible characters.

wire communications	A communications method in which signals are sent over wire cable. Although noise resistance and transmission distance can sometimes be a problem with wire communications, they are still the cheapest and the most common, and perfectly adequate for many applications.
Wired Master	A Remote I/O Master Unit connected via 2-conductor wire cables.
Wired Master	A Remote I/O Slave Unit connected via 2-conductor wire cables.
Wired Slave Rack	A Slave Rack connected through a Wired Slave.
Wired System	A Remote I/O Master System connected via 2-conductor wire cables.
word	A unit of data storage in memory that consists of 16 bits. All data areas consists of words. Some data areas can be accessed only by words; others, by either words or bits.
word address	The location in memory where a word of data is stored. A word address must specify (sometimes by default) the data area and the number of the word that is being addressed.
word allocation	The process of assigning I/O words and bits in memory to I/O Units and terminals in a PC System to create an I/O Table.
Word Grouping	See <i>custom data area</i> .
work area	A part of memory containing work words/bits.
work bit	A bit in a work word.
work disk	The location is memory when data currently being worked with is stored.
work word	A word that can be used for data calculation or other manipulation in programming, i.e., a 'work space' in memory. A large portion of the IR area is always reserved for work words. Parts of other areas not required for special purposes may also be used as work words.
write protect switch	A switch used to write-protect the contents of a storage device, e.g., a floppy disk. If the hole on the upper left of a floppy disk is open, the information on this floppy disk cannot be altered.
write-protect	A state in which the contents of a storage device can be read but cannot be altered.
zero-cross refresh	An I/O refresh process in which I/O status is refreshed when the voltage of an AC power supply is at zero volts.

Index

This index covers all three CVSS Operation Manuals. The manual the page numbers refer to is given in italics just prior to the number: Basics, Online, and Offline.

Symbols

.COD extension: *Basics* 64, 78

A

abbreviations: *Basics* 16; *Offline* 13; *Online* 13

action blocks

editing: *Offline* 32

AQ: *Offline* 34

FV: *Offline* 35

SV: *Offline* 34

execution time: *Offline* 35

leading zeros: *Offline* 37

monitoring: *Online* 20

SV: *Online* 21

action programs: *Basics* 43

SFC: *Basics* 59

addresses

changing, ladder: *Offline* 103

changing word and bit addresses together, ladder: *Offline* 109

I/O monitoring, ladder: *Online* 44

Alt Key: *Basics* 30

ASCII: *Basics* 66

AUTOEXEC.BAT: *Basics* 25

AUTOEXEC.CVS: *Basics* 25

B

Backspace Key: *Basics* 30

bit addresses, changing, ladder: *Offline* 87, 103, 107

block comments: *Basics* 44

comments used, ladder: *Offline* 70

creating, ladder: *Offline* 99

used, SFC: *Offline* 19

C

Capitals Lock Key: *Basics* 30

character keys: *Basics* 29

checking procedure

ladder: *Offline* 119

SFC: *Offline* 46

clearing

action blocks, SFC: *Offline* 38

errors, ladder: *Online* 42

memory areas

ladder: *Online* 54

SFC: *Online* 29

multiple SFC parts: *Offline* 42

SFC parts: *Offline* 32

clearing memory

ladder: *Offline* 65

related operations, ladder: *Offline* 66

SFC: *Offline* 17

clearing programs

ladder: *Offline* 66, 67, 69

specified ranges: *Offline* 68

SFC: *Offline* 17, 18

sheets, SFC: *Offline* 18

clock

displaying: *Online* 149

setting: *Online* 149

CNT, changing, ladder: *Offline* 103, 107

columns

clearing from SFC: *Offline* 42

copying in SFC: *Offline* 41

creating, ladder: *Offline* 89

deleting, ladder: *Offline* 89

entering in SFC: *Offline* 40

comments, finding, ladder: *Offline* 99

communication unit settings, Link Units: *Online* 105

compare, programs: *Offline* 211; *Online* 84

conditional branch, clearing, SFC: *Offline* 32

conditions, finding, ladder: *Offline* 97

CONFIG.SYS: *Basics* 25

connecting

computer to PC: *Basics* 18, 65

computer to printer: *Basics* 19

hood assembly: *Basics* 22

shielded wire not connecting to FG: *Basics* 21

shielded wire to FG: *Basics* 20

soldering: *Basics* 21

connectors

RS-232C: *Basics* 18, 20

RS-422: *Basics* 20

continuing operation, example, ladder: *Offline* 85, 86

control bits, data tracing: *Online* 60

converting

SFC or ladder program to UM: *Offline* 208

maximum actions: *Offline* 209

maximum steps and transitions: *Offline* 209

protecting: *Offline* 210

SFC online editing space: *Offline* 210

UM: *Offline* 207

UM to SFC or ladder program: *Offline* 211

copying, floppy disks: *Basics 22*
CPU Bus Units, communication unit settings: *Online 104*
CPU SIOU Units
 software switches: *Online 112*
 system setup: *Online 111*
Ctrl Key: *Basics 30*
cursor
 action blocks, SFC: *Offline 33*
 DM: *Offline 152*
 editing DM: *Online 95*
 editing PC IDs: *Offline 187*
 general, SFC: *Offline 25*
 jumping, SFC: *Offline 44*
 ladder: *Offline 77*
 mnemonic display mode, ladder: *Offline 113*
 overview mode, SFC: *Offline 60*
 program view mode, SFC: *Offline 61*
Cursor Keys: *Basics 30*
custom data areas: *Offline 240; Online 164*
 comparing: *Online 165*
 downloading: *Online 165*
 menu: *Offline 240*
 retrieving: *Offline 243*
 saving: *Offline 243*
 uploading: *Online 165*
CVSS
 setting operating environment: *Basics 49, 72*
 starting: *Basics 49, 72*
CVSS package: *Basics 2, 22*

D

data area lists: *Offline 194*
 cross-references: *Offline 195*
 printing
 cross-reference lists: *Offline 197*
 used data areas: *Offline 196*
 used data areas with I/O comments: *Offline 197*
 used data areas: *Offline 194*
 with I/O comments: *Offline 195*
data areas: *Basics 14, 38; Offline 11; Online 11*
data disks: *Basics 37*
data file structure: *Basics 40*
 directories: *Basics 41*
data storage: *Basics 38*
data tracing: *Offline 197; Online 60*
 cancelling: *Online 66*
 control bits and flags: *Online 60*
 executing: *Online 63, 65*
 inputting parameters: *Online 65*
 resetting parameters: *Online 65*
 menu: *Online 62*
 menu operations: *Offline 198*
 reading: *Offline 198*
 retrieving: *Offline 198; Online 66*
 saving: *Offline 198; Online 66*
data types: *Basics 41*
 comments: *Basics 43*
 I/O names: *Basics 43*
 programming: *Basics 41*
 SFC: *Basics 41*
debugging: *Basics 3*
 procedure, ladder: *Online 57*
 section, ladder: *Online 56, 59*
 setting stop conditions, ladder: *Online 56, 59*
 specifying the first step, ladder: *Online 56*
 step, ladder: *Online 56, 58*
Del Key: *Basics 30*
DEVICE: *Basics 25*
Device Driver Path: *Basics 24*
DIET: *Basics 2; Offline 2; Online 2*
directories: *Basics 41*
display modes
 addresses and I/O names, ladder: *Offline 72*
 changing SFC settings: *Offline 20; Online 19*
 I/O addresses only, ladder: *Offline 72*
 I/O names and I/O comments, ladder: *Offline 73, 74*
 I/O names only, ladder: *Offline 73*
 instruction blocks, ladder: *Offline 71*
 mnemonic ladder programming: *Offline 74*
 program modes, ladder: *Offline 71*
 SFC programming menu: *Offline 16*
 switching procedure, ladder: *Offline 70, 72, 75*
DM
 changing prefixes: *Offline 241*
 copying: *Offline 153; Online 97*
 creating: *Offline 242*
 editing: *Online 95*
 initial display: *Online 95*
 switching pages: *Online 95*
 switching PC Modes: *Online 96*
 writing data: *Online 96*
 fill: *Offline 153; Online 97*
 HEX-ASCII switching: *Offline 154; Online 97*
 printing: *Offline 154; Online 97*
 reading an address: *Offline 153; Online 96*
 retrieving data: *Offline 156; Online 99*
 saving data: *Offline 155; Online 98*
 switching bank numbers: *Online 98*
 switching display pages: *Offline 152*
 transferring data: *Online 99*
 comparing data: *Online 101*
 downloading data: *Online 100*
 uploading data: *Online 101*
 writing data: *Offline 152*
DOS prompt: *Basics 23*
downloading
 custom data areas: *Online 165*
 DM data: *Online 100*
 EM data: *Online 100*
 from data disks: *Online 85*
 from hard disk: *Online 85*
 from work disk: *Online 83*
 routing tables: *Online 133*
 SYSMAC LINK data link tables: *Online 121*
 SYSMAC NET data link tables: *Online 115*

E

editing

DM: *Offline 151; Online 95*
examples, ladder: *Offline 87*
general online editing
 ladder: *Online 50*
 SFC: *Online 25*
I/O comments: *Offline 138*
I/O names: *Offline 131*
I/O table: *Offline 157*
 function key operations: *Offline 158*
I/O tables: *Online 90*
insert mode, ladder: *Offline 89*
modes, ladder: *Offline 65*
monitor display, ladder: *Online 35*
network support tables: *Offline 169*
PC IDs: *Offline 186*
 function key operations: *Offline 187*
PC Mode, SFC: *Online 27*
related operations, ladder: *Online 52*
set values, ladder: *Online 37*
settings, SFC: *Offline 20; Online 18*
step status, SFC: *Online 30*
steps, SFC: *Offline 38*
transitions, SFC: *Offline 38*
write mode, ladder: *Offline 87*

EM, transferring data

comparing data: *Online 102*
downloading data: *Online 100*
uploading data: *Online 101*

End Key: *Basics 30*

Enter Key: *Basics 30*

entering

action blocks, SFC: *Offline 38*
addresses, ladder: *Offline 79*
conditions, ladder: *Offline 77*
initial steps, SFC: *Offline 30*
instructions, ladder: *Offline 116*
interrupt numbers: *Offline 29*
ladder diagrams: *Offline 77*
 basic instructions: *Offline 80*
 using function codes: *Offline 81*
mnemonic display mode, ladder: *Offline 113*
mnemonics with the function keys: *Offline 113*
operands, ladder: *Offline 79*
SFC jumps: *Offline 30*
SFC parts: *Offline 26*
step numbers, SFC: *Offline 28*
subchart dummy step, SFC: *Offline 31*
text, SFC: *Offline 27*
transition numbers, SFC: *Offline 28*

error messages: *Basics 88; Online 148*

access right: *Online 149*
all levels, ladder: *Offline 120*
check level A, SFC: *Offline 46*
check level B, SFC: *Offline 48*
check level C, SFC: *Offline 49*
current directory: *Online 148*
history: *Online 149*
I/O tables: *Offline 167*
link program: *Offline 149*

routing tables

 local network table: *Offline 184*
 relay network tables: *Offline 184*
SYSMAC LINK data link parameters
 common link parameters: *Offline 178*
 refresh parameters: *Offline 178*
SYSMAC NET data link tables: *Offline 172*

Esc Key: *Basics 30*

execution time, measuring, ladder: *Online 53*

F

files

changing drive and path name: *Offline 205*
copying: *Offline 204*
creating and deleting directories: *Offline 205*
data
 retrieving: *Offline 157*
 saving: *Offline 156*
deleting: *Offline 205*
directories: *Offline 204*
management: *Offline 203*
 memory card: *Online 152*
 menu operations: *Basics 5; Offline 2, 203; Online 2*
printing: *Offline 206*
renaming: *Offline 205*

FINS command response codes, displays: *Basics 93*

flags, data tracing: *Online 60*

floppy disks

 copying: *Basics 22*
 formatting: *Basics 63, 77*
 using: *Basics 22*

FORMAT: *Offline 202*

formatting floppy disk: *Basics 63, 77*

function codes

 changing: *Offline 241*
 customizing: *Offline 240*
 menu: *Offline 240*
 retrieving: *Offline 243*
 saving: *Offline 243*

function keys: *Basics 31*

 debugging, ladder: *Online 56*
 I/O monitoring, ladder: *Online 45*
 I/O tables: *Online 88*
 monitoring display, ladder: *Online 36*
 read mode, ladder: *Offline 94*
 write mode, ladder: *Offline 76*

H

HIS programs: *Offline 239–240*

 deleting: *Offline 240*
 recording: *Offline 239*

Home Key: *Basics 30*

hood assembly: *Basics 22*

I

I/O addresses

- checking: *Offline 136*
- displays: *Basics 85*
- later assignment of I/O addresses: *Basics 84*
- specifying: *Offline 140*

I/O comments: *Basics 43*

- clearing: *Offline 141*
- comment change, ladder: *Offline 106*
- comments used
 - ladder: *Offline 70*
 - SFC: *Offline 19*
- displaying: *Offline 74*
- finding: *Offline 142*
- printing: *Offline 141*
- retrieving: *Offline 140*
- saving: *Offline 140*

I/O monitoring

- all I/O monitor display, ladder: *Online 42*
- alphanumeric key input, ladder: *Online 45*
- ASCII, ladder: *Online 46*
- clearing, ladder: *Online 46*
- editing PV, ladder: *Online 47*
- example, ladder: *Online 46*
- force reset, ladder: *Online 46*
- force set, ladder: *Online 46*
- input area, ladder: *Online 43*
- part I/O monitor display, ladder: *Online 42*
- pause monitor, ladder: *Online 48*
- SFC: *Online 24*
- writing, ladder: *Online 45*

I/O names: *Basics 81*

- assigning names: *Basics 81*
- basic editing procedure: *Offline 133*
- checking: *Offline 136*
- clearing: *Offline 134*
- deleting unused names: *Offline 136*
- displays: *Basics 85*
- edit mode key operations: *Offline 139*
- edit mode key sequences: *Offline 132*
- editing: *Offline 132*
- finding: *Offline 137*
- later assignment of I/O addresses: *Basics 84*
- linking to programs: *Offline 136*
- name change, ladder: *Offline 104*
- names used
 - ladder: *Offline 70*
 - SFC: *Offline 19*
- printing: *Offline 135*
- retrieving: *Offline 134*
- saving: *Offline 133*
- sorting: *Offline 137*
- writing: *Offline 132*
- writing a program with I/O names: *Basics 82*

I/O tables: *Online 86*

- checking: *Offline 167; Online 94*
 - error messages: *Offline 167*
- clearing: *Offline 169*
- comparing: *Online 93*
- creating: *Online 93*
- customizing: *Offline 169*

displaying

- SYSMAC BUS Slaves: *Online 89*
- SYSMAC BUS/2 Slaves: *Online 88*

editing: *Online 90*

entering

- CPU Bus Units: *Offline 162*
- I/O Terminals: *Offline 166*
- SYSMAC BUS Slaves: *Offline 166*
- SYSMAC BUS/2 Group-1 Slaves: *Offline 163*
- SYSMAC BUS/2 Group-2 Slaves: *Offline 164*
- SYSMAC BUS/2 Group-3 Slaves: *Offline 165*

guidance displays

- CPU Bus Unit: *Online 90*
- Group-2 events: *Online 90*
- I/O terminals: *Online 90*
- I/O Units: *Online 90*
- interrupt units: *Online 90*
- SYSMAC BUS Masters: *Online 90*

PC Setup: *Offline 169; Online 94*

registering: *Basics 66*

retrieving: *Offline 169*

saving: *Offline 168*

transferring: *Online 92*

- computer to PC: *Online 92*
- PC to computer: *Online 92*

writing

- basic racks: *Offline 159*
- C-series allocations: *Offline 161*
- function keys: *Offline 160*
- help screen: *Offline 162*
- Slave limitations: *Offline 162*

IEC standards: *Basics 3*

initialization: *Offline 202*

Ins Key: *Basics 30*

installing

- CVSS: *Basics 23*
- display: *Basics 24*

instruction blocks

- editing, ladder: *Offline 101*
- editing operations, ladder: *Offline 102*
- editing procedure, ladder: *Offline 102*
- ladder: *Offline 71*

instructions

- finding, ladder: *Offline 97*
- function codes, ladder: *Basics 10; Offline 7; Online 7*
- mnemonics list, ladder: *Basics 12; Offline 9; Online 9*
- reading, ladder: *Offline 95*
- reading previous or next block, ladder: *Offline 96*
- scrolling large blocks, ladder: *Offline 96*
- tracing: *Online 71*

interrupt programs, editing, ladder: *Offline 111; Online 52*

K

keyboard: *Basics 29*

- character keys: *Basics 29*
- function keys: *Basics 31*
- special keys: *Basics 30*

L

ladder diagrams

preparations

- clearing memory: *Offline 75*
- setting display mode: *Offline 75*
- setting editing mode: *Offline 75*
- reversing NO and NC: *Offline 89*

ladder programs

- backing up the program: *Basics 77*
- creating: *Basics 73*
- guidelines: *Basics 72*
- monitoring: *Basics 78*
- overview: *Basics 71*
- procedures: *Basics 72*
- view mode: *Basics 29*

Ladder Support Software, comparison with CVSS: *Basics 4*

line connections

- connecting instruction lines, ladder: *Offline 84*
- connecting multiple inputs, ladder: *Offline 84*
- continuing operation, ladder: *Offline 85*
- creating a blank line, ladder: *Offline 89*
- deleting, ladder: *Offline 82*
- deleting a blank line, ladder: *Offline 89*
- deleting vertical connections, ladder: *Offline 88*
- entering, ladder: *Offline 82*
- examples, ladder: *Offline 82*
- horizontal connections, ladder: *Offline 83*

lines

- clearing from SFC: *Offline 41*
- copying in SFC: *Offline 41*
- entering in SFC: *Offline 40*

Link Units, software switches: *Online 104*

links: *Offline 142*

- executing: *Offline 147*
- link mode, setting: *Offline 147*
- parameters
 - clearing: *Offline 150*
 - creating: *Offline 143, 144*
 - I/O comments: *Offline 143*
 - I/O names: *Offline 143*
 - printing: *Offline 150*
 - retrieving: *Offline 150*
 - save: *Offline 150*
 - SFC programs: *Offline 143*
- program
 - edit mode key operations: *Offline 146*
 - menu: *Offline 146*

M

main offline menu: *Basics 28*

marks, tracing: *Online 77*

memory

- capacity, ladder: *Offline 70*
- configuration: *Basics 37*
- display
 - ladder: *Offline 69*

- SFC: *Offline 19*
- left, PC: *Offline 19*

map

- ladder: *Online 35*
- SFC: *Online 26*

media: *Basics 37*

- data disks: *Basics 37*
- main memory: *Basics 37*
- work disks: *Basics 37*

required, PC: *Offline 19*

used

- ladder: *Offline 70*
- ladder-diagram: *Offline 19*
- SFC: *Offline 19*

memory areas, clearing

- ladder: *Online 54*
- SFC: *Online 29*

memory banks, switching: *Offline 155*

memory card

- copying files: *Offline 215*
- deleting files: *Offline 215*
- initialization: *Offline 215*
- Memory Card Writer: *Offline 213*
 - buffer RAM: *Offline 213*
- menu operations: *Offline 214*
- printing: *Offline 216*
- renaming files: *Offline 215*
- transferring files
 - computer to memory card: *Offline 215*
 - memory to computer: *Offline 215*

memory cards: *Online 152*

- changing files: *Online 158*
- clearing files: *Online 159*
- copying files: *Online 158*
- file management: *Online 152*
 - menu operations: *Online 152*
- file types and extensions: *Online 154*
- initializing: *Online 154*
- menu operations: *Online 153*
- transferring between computer and memory card: *Online 158*
- transferring from memory card to PC
 - all programs: *Online 157*
 - extended PC Setup: *Online 158*
 - IOM words: *Online 157*
- transferring from PC to memory card
 - extended PC Setup: *Online 157*
 - IOM words: *Online 156*
 - programs: *Online 155*

mnemonic display mode

- alphanumeric key input, ladder: *Offline 115*
- changing instructions, ladder: *Offline 117*
- correcting input characters, ladder: *Offline 116*
- deleting instructions, ladder: *Offline 118*
- editing numbers, ladder: *Offline 115*
- entering bit addresses, ladder: *Offline 115*
- entering data, ladder: *Offline 115*
- entering instructions, ladder: *Offline 115*
- entering word addresses, ladder: *Offline 115*
- inserting instructions, ladder: *Offline 117*
- main programming menu, ladder: *Offline 113*
- preparations, ladder: *Offline 112*
- programming screen, ladder: *Offline 112*

reading programs, ladder: *Offline 118*

monitoring: *Basics 3*

action status: *Online 23*

 clear: *Online 24*

 PV: *Online 24*

 range: *Online 24*

 SV: *Online 24*

cross-references

 ladder: *Online 41*

 SFC: *Online 25*

cycle time, SFC: *Online 28*

differentiate monitor, ladder: *Online 40*

function keys, ladder: *Online 34*

initial display, SFC: *Online 19*

ladder programs: *Basics 78*

menu

 ladder: *Online 34*

 SFC: *Online 16*

pause monitor, ladder: *Online 38*

SFC programs: *Basics 68*

moving, multiple SFC parts: *Offline 43*

N

number of displayed steps, changing SFC settings: *Offline 22*;
Online 19

Numerical Lock Key: *Basics 31*

numeric ranges permitted: *Offline 49*

O

offline

 data flow: *Basics 37*

 data areas: *Basics 38*

 data storage: *Basics 38*

edit

 DM operations: *Basics 7*; *Offline 4*; *Online 4*

 I/O table operations: *Basics 7*; *Offline 4*; *Online 4*

 miscellaneous operations: *Basics 7*; *Offline 4*; *Online 4*

programming

 ladder-only mode: *Basics 6*; *Offline 3*; *Online 3*

 SFC detail view mode: *Basics 5*; *Offline 2*; *Online 2*

 SFC program view: *Basics 6*; *Offline 3*; *Online 3*

offline operations: *Basics 32*

 Command.com: *Basics 34*

 Convert UM: *Basics 34*

 Customize: *Basics 34*

 Data Area Lists: *Basics 33*

 Data trace: *Basics 33*

 Edit DM: *Basics 33*

 Edit I/O comments: *Basics 33*

 Edit I/O names: *Basics 33*

 Edit I/O table: *Basics 33*

 Edit PC ID: *Basics 33*

 End: *Basics 34*

 File management: *Basics 33*

 Format floppy: *Basics 34*

 Memory card: *Basics 34*

 Network support table: *Basics 34*

PC setup: *Basics 34*

Program: *Basics 32*

Program Link: *Basics 33*

System setup: *Basics 33*

online

 data flow: *Basics 38*

 edit

 DM operations: *Basics 9*; *Offline 6*; *Online 6*

 I/O table operations: *Basics 9*; *Offline 6*; *Online 6*

 going online: *Basics 65*

 miscellaneous operations: *Basics 9*; *Offline 6*; *Online 6*

 monitoring

 ladder mode: *Basics 8*; *Offline 6*; *Online 6*

 SFC detail view mode: *Basics 8*; *Offline 5*; *Online 5*

 SFC program view: *Basics 8*; *Offline 6*; *Online 6*

 transfer program and data: *Basics 8*; *Offline 5*; *Online 5*

online operations: *Basics 34*

 Clock: *Basics 36*

 CPU Bus Unit setup: *Basics 36*

 Customize: *Basics 36*

 Data trace: *Basics 35*

 Debug: *Basics 35*

 Diagnosis network: *Basics 36*

 Edit DM: *Basics 35*

 Edit I/O table: *Basics 35*

 File management: *Basics 36*

 Memory card: *Basics 36*

 Monitor: *Basics 35*

 Network support table: *Basics 36*

 PC setup: *Basics 36*

 Program trace: *Basics 36*

 Protect UM: *Basics 36*

 Read errors: *Basics 36*

 SYSMAC BUS/2: *Basics 36*

 System setup: *Basics 36*

 Transfer program & data: *Basics 35*

operands, finding, ladder: *Offline 98*

operating modes: *Basics 28*

 ladder program view: *Basics 29*

 overview: *Basics 29*

 SFC detail view: *Basics 28*

overview mode: *Basics 29*

 SFC: *Offline 59*; *Online 31*

P

PC ID, I/O monitoring: *Online 44*

PC IDs

 changing: *Offline 188*

 checking: *Offline 191*

 clearing: *Offline 190*

 edit menu: *Offline 189*

 fill: *Offline 190*

 finding: *Offline 192*

 printing: *Offline 190*

 retrieving: *Offline 189*

 saving: *Offline 189*

 sorting: *Offline 191*

 writing: *Offline 188*

- PC Setup: *Offline 221; Online 163*
- clearing: *Offline 239*
- displays
 - CPU Bus Links: *Offline 233*
 - cycle monitoring time: *Offline 237*
 - cycle time: *Offline 236*
 - display mode at startup: *Offline 238*
 - error log area: *Offline 237*
 - execution controls 1: *Offline 232*
 - execution controls 2: *Offline 232*
 - first words for Group-1 and Group-2 Slaves: *Offline 234*
 - first words for Group-3 Slaves: *Offline 235*
 - first words for I/O terminals: *Offline 235*
 - first words for local racks: *Offline 234*
 - holding bits: *Offline 229*
 - host link: *Offline 233*
 - I/O refresh: *Offline 231*
 - momentary power interruption time: *Offline 236*
 - scheduled interrupt interval: *Offline 233*
 - startup hold: *Offline 230*
 - startup mode: *Offline 230*
 - startup processing: *Offline 230*
- menu operations: *Online 163*
- retrieving: *Offline 238; Online 164*
- saving: *Offline 238; Online 164*
- setting: *Online 164*
- system setup: *Offline 222*
 - default settings: *Offline 228*
 - details: *Offline 224*
 - overview: *Offline 222*
- transferring: *Online 164*

- PgDn Key: *Basics 31*

- PgUp Key: *Basics 31*

- pins, functions: *Basics 20*

- printers, models: *Basics 20*

- printing
 - all sheets, SFC: *Offline 53*
 - current sheet, SFC: *Offline 59*
 - examples
 - ladder: *Offline 127*
 - SFC: *Offline 56*
 - ladder diagrams: *Offline 125*
 - mnemonics, ladder: *Offline 127*
 - procedure, ladder: *Offline 124*
 - settings, ladder: *Offline 126*

- program addresses, retrieving, ladder: *Offline 96*

- program tracing: *Online 67*
 - action traces: *Online 68*
 - executing: *Online 68*
 - retrieving: *Online 70*
 - instructions: *Online 71*
 - executing: *Online 72*
 - retrieving: *Online 74*
 - mark traces: *Online 77*
 - executing: *Online 77*
 - retrieving: *Online 79*

- program view mode
 - preparations, SFC: *Online 31*
 - returning to detail view, SFC: *Online 32*
 - selecting steps, SFC: *Online 31*
 - selecting transitions, SFC: *Online 32*
 - SFC: *Offline 61*
 - specifying blanks, SFC: *Online 32*

- programming
 - general, SFC: *Offline 24*
 - input screen, ladder: *Offline 75*
 - ladder: *Offline 75*
 - menu
 - ladder: *Offline 64*
 - SFC: *Offline 16*
 - preparations for SFC: *Offline 24*
 - screen
 - ladder: *Offline 64*
 - SFC: *Offline 24*

- programs
 - comparing: *Offline 211; Online 84*
 - structure: *Basics 41*
 - writing with I/O names: *Basics 82*

- PrtSc Key: *Basics 31*

R

- RAM disks: *Basics 37*

- response codes, FINS commands, displays: *Basics 93*

- retrieving
 - data trace: *Online 66*
 - DM data: *Online 99*
 - examples, ladder: *Offline 96*
 - ladder: *Offline 93; Online 37*
 - ladder programs: *Offline 95*
 - ladder read screen: *Offline 93*
 - PC Setup: *Online 164*
 - programs
 - ladder: *Offline 123*
 - SFC: *Offline 53*
 - sheets, SFC: *Offline 49*

- routing tables
 - C-series PCs communication: *Offline 182*
 - checking: *Offline 183*
 - clearing: *Offline 184; Online 132*
 - comparing: *Online 133*
 - display: *Online 130*
 - downloading: *Online 133*
 - editing
 - local network table: *Offline 182*
 - relay network table: *Offline 183*
 - error message table
 - local network table: *Offline 184*
 - relay network table: *Offline 184*
 - local network table: *Offline 180*
 - menu: *Offline 181; Online 131*
 - network communication range: *Offline 181*
 - printing: *Offline 185*
 - relay network table: *Offline 181*
 - retrieving: *Offline 185; Online 131*
 - saving: *Offline 184; Online 134*
 - transferring: *Online 131*
 - uploading: *Online 132*

S

- saving
 - PC Setup: *Online 164*
 - programs
 - ladder: *Offline 121*
 - SFC: *Offline 52*
 - sheets, SFC: *Offline 49*
- screen displays: *Basics 28*
 - main offline menu: *Basics 28*
- searching, ladder: *Offline 93*
- SFC
 - action programs: *Basics 59*
 - backing up the program: *Basics 63*
 - creating SFC: *Basics 50*
 - detail view mode: *Basics 28*
 - guidelines: *Basics 49*
 - monitoring: *Basics 68*
 - overview: *Basics 48*
 - procedures: *Basics 49*
 - registering I/O tables: *Basics 66*
 - transferring programs: *Basics 67*
 - transition programs: *Basics 59*
- sheets
 - retrieving, SFC: *Offline 51*
 - saving, SFC: *Offline 49*
 - size, changing SFC settings: *Offline 23; Online 19*
 - transferring
 - computer to PC: *Online 27*
 - PC to computer: *Online 26*
 - related operations: *Online 28*
 - SFC: *Online 16*
 - writing, SFC program view mode: *Offline 61*
- shielded wire: *Basics 20*
- Shift Key: *Basics 31*
- software switches
 - CPU SIOU Units: *Online 112*
 - Link Units: *Online 104*
 - settings
 - SYSMAC BUS/2 Masters: *Online 110*
 - SYSMAC LINK: *Online 110*
 - SYSMAC NET: *Online 109*
- soldering: *Basics 21*
- SPDTLDRV.SYS: *Basics 25*
- SPDWADRV.SYS: *Basics 25*
- special keys: *Basics 30*
 - Alt Key: *Basics 30*
 - Backspace Key: *Basics 30*
 - Capital Lock Key: *Basics 30*
 - Ctrl Key: *Basics 30*
 - Cursor Keys: *Basics 30*
 - Del Key: *Basics 30*
 - End Key: *Basics 30*
 - Enter Key: *Basics 30*
 - Esc Key: *Basics 30*
 - Home Key: *Basics 30*
 - Ins Key: *Basics 30*
 - Numeral Lock Key: *Basics 31*
 - PgDn Key: *Basics 31*
 - PgUp Key: *Basics 31*
 - PrtSc Key: *Basics 31*
 - Shift Key: *Basics 31*
 - Tab Key: *Basics 31*
- specifications, computer: *Basics 2*
- starting, CVSS: *Basics 25, 49, 72*
- steps
 - clearing, SFC: *Offline 32*
 - editing operations, SFC: *Offline 39*
 - monitoring
 - clear: *Online 23*
 - range: *Online 22*
 - SFC: *Online 21*
 - specifying, SFC program view mode: *Offline 62*
- store
 - editing, ladder: *Offline 90*
 - program sections not applicable, ladder: *Offline 91*
- store insert
 - editing, ladder: *Offline 90*
 - program sections not applicable, ladder: *Offline 91*
- symbols
 - deleting, ladder: *Offline 88*
 - inserting, ladder: *Offline 88*
- SYSMAC BUS/2 Remote I/O System
 - communication cycle time: *Online 109*
 - communication error process: *Online 108*
 - error check: *Online 108*
 - hardware checks: *Online 109*
 - response monitor time: *Online 109*
 - transfer error count: *Online 109*
- SYSMAC BUS/2 support: *Online 141*
 - activating Slaves: *Online 144*
 - displaying status: *Online 142*
 - inactivating Slaves: *Online 144*
 - line mode: *Online 145*
 - reading cycle time: *Online 143*
 - Slave connection status: *Online 143*
 - testing: *Online 142*
- SYSMAC LINK data link tables: *Offline 173*
 - checking: *Offline 177*
 - clearing: *Offline 179; Online 126*
 - common link parameter screen: *Offline 173*
 - communication cycle time: *Online 129*
 - comparing: *Online 123*
 - copying: *Offline 178*
 - downloading: *Online 121*
 - editing: *Offline 175*
 - editing refresh parameters: *Offline 176*
 - error message table
 - common link parameter: *Offline 178*
 - refresh parameter: *Offline 178*
 - function keys: *Offline 175*
 - menu: *Offline 174; Online 118*
 - monitoring status: *Online 128*
 - node refresh parameter screen: *Offline 174*
 - parameter ranges: *Offline 177*
 - printing: *Offline 180*
 - refresh cycle time: *Online 130*
 - retrieving: *Offline 179; Online 120*
 - saving: *Offline 179; Online 127*
 - starting and stopping: *Online 127*

transferring: *Online 120*
uploading: *Online 120*

SYSMAC LINK Systems

data link areas: *Online 107*
number of words: *Online 107*
setting polled or polling: *Online 108*

SYSMAC NET data link tables: *Offline 170; Online 114*

checking: *Offline 171*
error message table: *Offline 172*
clearing: *Offline 172*
comparing: *Online 116*
downloading: *Online 115*
editing: *Offline 171*
monitoring status: *Online 117*
printing: *Offline 173*
retrieving: *Offline 172; Online 114*
saving: *Offline 172; Online 116*
starting and stopping: *Online 117*
transferring: *Online 114*
uploading: *Online 115*

SYSMAC NET Link Systems

Binary and ASCII: *Online 106*
data link areas: *Online 106*
datagram format: *Online 106*
Master and Slave: *Online 106*
number of words: *Online 106*
transfer delay time: *Online 106*

system disks: *Basics 2, 22; Offline 2; Online 2*

system settings: *Basics 5; Offline 2; Online 2*

system setup: *Offline 218; Online 162*

communications mode: *Offline 218*
ASCII: *Offline 219*
binary: *Offline 219*
CPU SIOU Units: *Online 111*
destination network: *Online 162*
host interface specifications: *Online 163*
Memory Card Writer: *Offline 221*
menu operations: *Online 162*
message number: *Offline 221; Online 163*
printer: *Online 163*
printer type: *Offline 221*
program check PC: *Offline 221*
program type: *Offline 221*

T

Tab Key: *Basics 31*

testing: *Online 134*

SYSMAC LINK: *Online 137*
broadcast test: *Online 138*
internode test: *Online 137*
network parameters: *Online 140*
node status: *Online 139*

unit error history: *Online 140*
SYSMAC NET: *Online 135*
internode test: *Online 135*
node status: *Online 136*
unit error history: *Online 136*

text input

action blocks, SFC: *Offline 36*
changing SFC settings: *Offline 20; Online 19*

TIM, changing, ladder: *Offline 103, 107*

transferring

data: *Online 82*
program data from PC: *Basics 45*
program data to data disk: *Basics 44*
program data to PC: *Basics 44*
programs: *Online 82*
SFC programs: *Basics 67*

transition programs: *Basics 43*

SFC: *Basics 59*

transitions

editing operations, SFC: *Offline 39*
specifying, SFC program view mode: *Offline 62*

U

UM

clearing all protection: *Online 166*
converting: *Offline 207*
partially clearing protection: *Online 166*
protecting: *Online 165, 166*

uploading

custom data areas: *Online 165*
DM data: *Online 101*
EM data: *Online 101*
routing tables: *Online 132*
SYSMAC LINK data link tables: *Online 120*
SYSMAC NET data link tables: *Online 115*
to data disk: *Online 85*
to hard disk: *Online 85*
to work disk: *Online 83*

V

VDISK.SYS: *Basics 24, 25*

W

wire connectors: *Basics 20*

word addresses, changing, ladder: *Offline 108, 109*

work disks: *Basics 22, 37*

writing, cycle time, ladder: *Online 52*

Revision History

A manual revision code appears as a suffix to the catalog number on the front cover of the manual.

Cat. No. W201-E1-2
 Revision code

The following table outlines the changes made to the manual during each revision. Page numbers refer to the previous version.

Revision code	Date	Revised content
1	May 1992	Original production
2	February 1993	<p>The manual was revised accompany release of version 2 of the software. Major changes are outlined on page 3 of the <i>CV Support Software: Basics Operation Manual</i>. Other changes are as follows:</p> <p>Page 3: Note added to Memory Map description saying it is not supported in SFC program view mode.</p> <p>Page 5: Block Transfer changed to Transfer Program and Data.</p> <p>Page 64: Note at bottom changed to include “and “M:Memory map”.”</p> <p>Page 98: The first paragraph of <i>3-5 Creating Block Comments</i> has been rewritten.</p> <p>Page 114 and other: Need to input data area prefixes in upper-case removed.</p> <p>Page 125: Pagination items have been clarified.</p> <p>Page 204: A note has been added.</p> <p>Page 217 and 218: “SYSMAC BUS/2” was added for clarification for row “L” and “SYSMAC BUS/2 and SYSMAC BUS” was added for clarification for row “N.”</p> <p>Page 221: SYSMAC BUS was corrected to SYSMAC BUS/2 for the first line of “Operation” for row “N.”</p> <p>Page 222: IORF was corrected to IOIF for row T.</p>