

**New!**

**OMRON**

# **SYSMAC CS/CJ-Series Position Control Units**

**CJ1W-NCF71  
CS1W-NCF71 *NEW***

Transforming Devices with Motion Field Network  
MECHATROLINK-II-compatible Position Control Unit

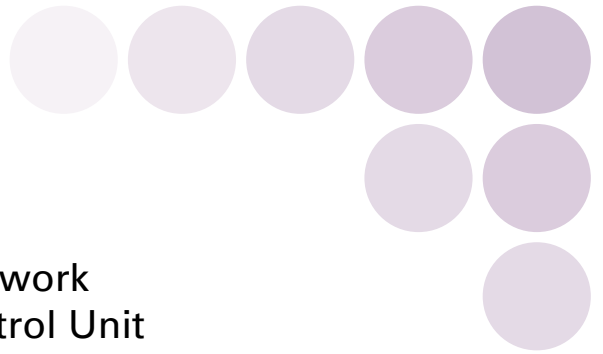

**realizing**

# Quick and Simple Multi-axis System

Introducing a Position Control Unit that can control up to 16 axes across a MECHATROLINK-II\* high-speed field network. With it, every aspect of multi-axis systems from machine design to future expansions can be changed quickly and simply.

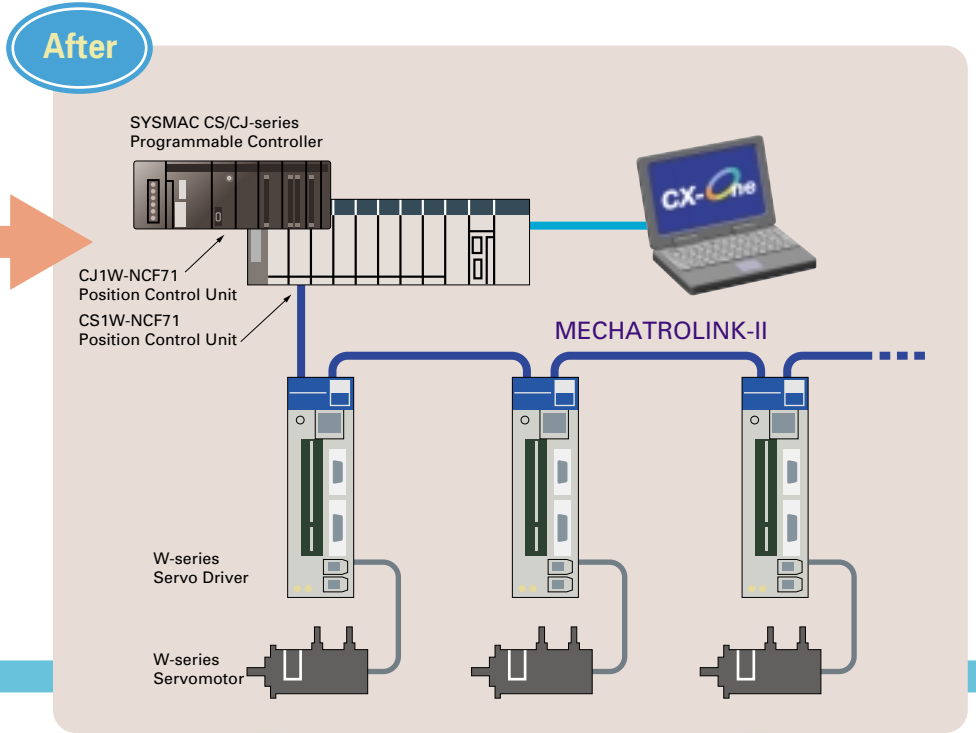
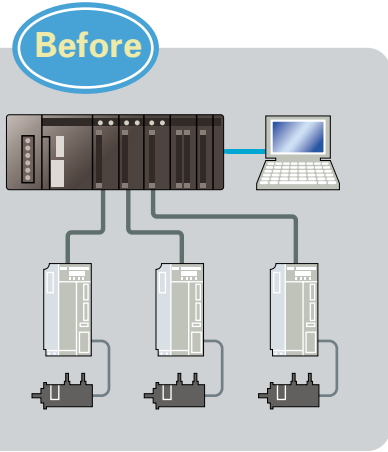

- Routing wires was difficult because of the number of wires involved.
- Expanding or modifying equipment was complicated because the number of axes dictated the number of Units.
- Settings took time because Controllers and Servo Drivers had to be set separately.

## More Compact

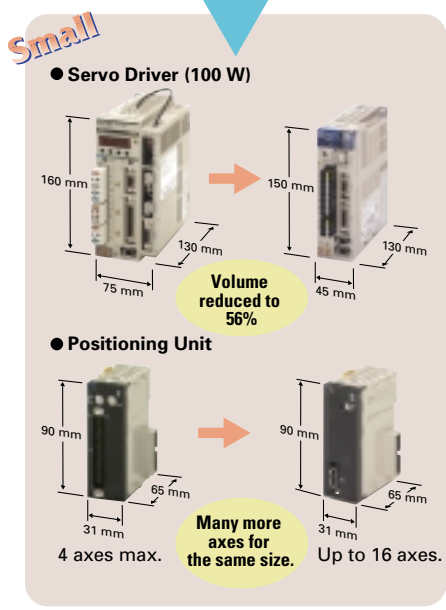

## Less Wiring

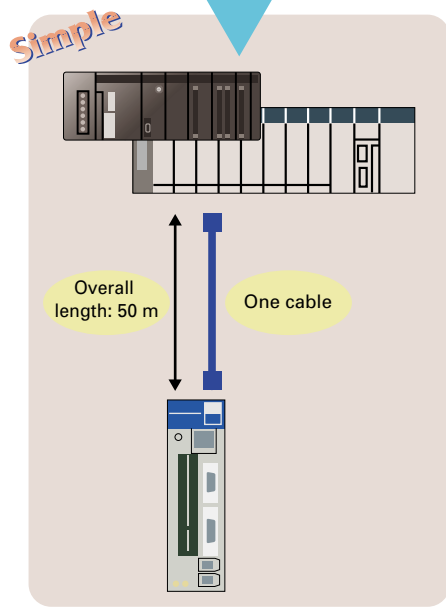

## Centralized Data Control

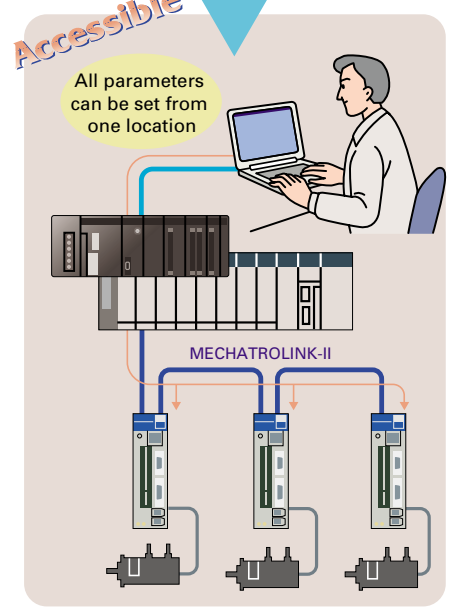

### Even smaller

Previously, W-series Units had to be connected to a MECHATROLINK-II Module. Now, OMNUC W-series AC Servo Drivers with built-in MECHATROLINK-II communications are available. This reduces the volume to 2/3 or more of previous models.

### Single-cable connection offers wiring flexibility

Servo Driver connection was greatly simplified: just one shielded twisted-pair cable is needed with a MECHATROLINK-II network. The overall cable length is 50 m (30 m max. with 16 axes connected) and there is less wiring and more flexibility in device arrangement.

### Less Time Spent on Startup and Maintenance

Servo Driver parameters can be set from the PLC. This means that settings and adjustments can be performed from one location rather than having to connect a Programming Device to each Servo Drive individually. Servo Drive alarm status and other information, such as speed and torque, can also be monitored from the PLC.

# Implementation

## A Whole New World of Machine Control from OMRON

OMRON has developed a whole new environment that seamlessly integrates different control devices and networks over the entire life cycle of equipment and machines, ranging from design and startup to operation and maintenance. The system will still be viable as new systems are developed and new control devices and controllers become available. It all begins with OMRON Standard Libraries.

### OMRON Standard Libraries

OMRON Standard Libraries are software applications that customers can load into their system and use without modification. The OMRON FB Library and Smart Active Parts (SAPs) Library are available now. These libraries simplify the software developed for interface components between Programmable Controllers (PLCs) or Programmable Terminals and various other control devices. They also improve the quality of the software by using standardized software components.

### OMRON FB Library

The OMRON FB Library contains functional components for Programmable Controllers (PLCs). These components can be used by customers to produce finished programs that interface with various control devices in much less time. Since the components are standardized, they also improve the quality of the finished programs.

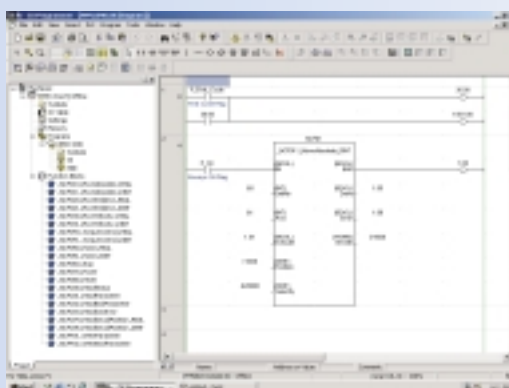

Frequently used ladder programming is provided in each function block. Several function blocks form a library that facilitates program and program asset development.

### Smart Active Parts (SAPs) Library

The Smart Active Parts (SAPs) Library, formerly known as the Device Library, consists of screens with functions for Programmable Terminals. SAPs can be used on screens developed by customers to produce finished screens that interface with various control devices in much less time. Since the components are standardized, they also improve screen quality.

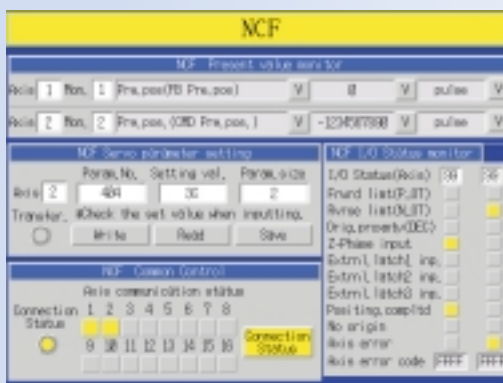

The SAPs include various operating screens for Position Control Units. Simply paste SAPs to simplify design work and eliminate unnecessary user programming.

The OMRON FB Library and Smart Active Parts Library can be used with CS/CJ-series Programmable Controller CPU Units version 3.0 or later and NS-series Programmable Terminals version 6 or later, respectively.

### Multi-axis Control

Flexible

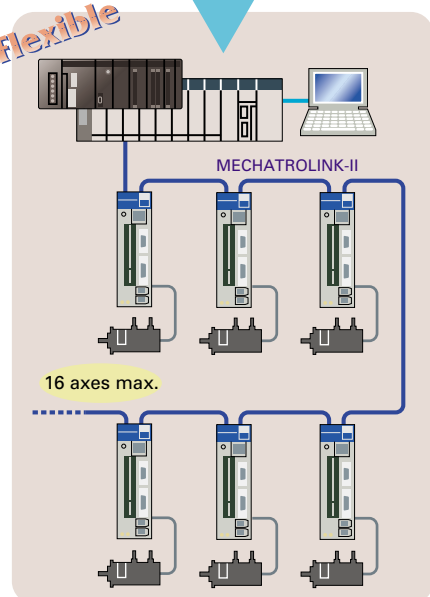

### Simple Expansion

An easily expandable system can be constructed that is just as efficient now with a few axes or later with up to 16 axes.

\*MECHATROLINK and MECHATROLINK are registered trademarks of Yaskawa Electric Corporation.

# Simplifying the Task of Designing Various T

## Assembly Equipment

Absolute and relative positioning of multiple axes can be performed by manipulating bits directly from the PLC. The target position and target speed can be changed instantly even while the positioning operation is in progress simply by sending another command.

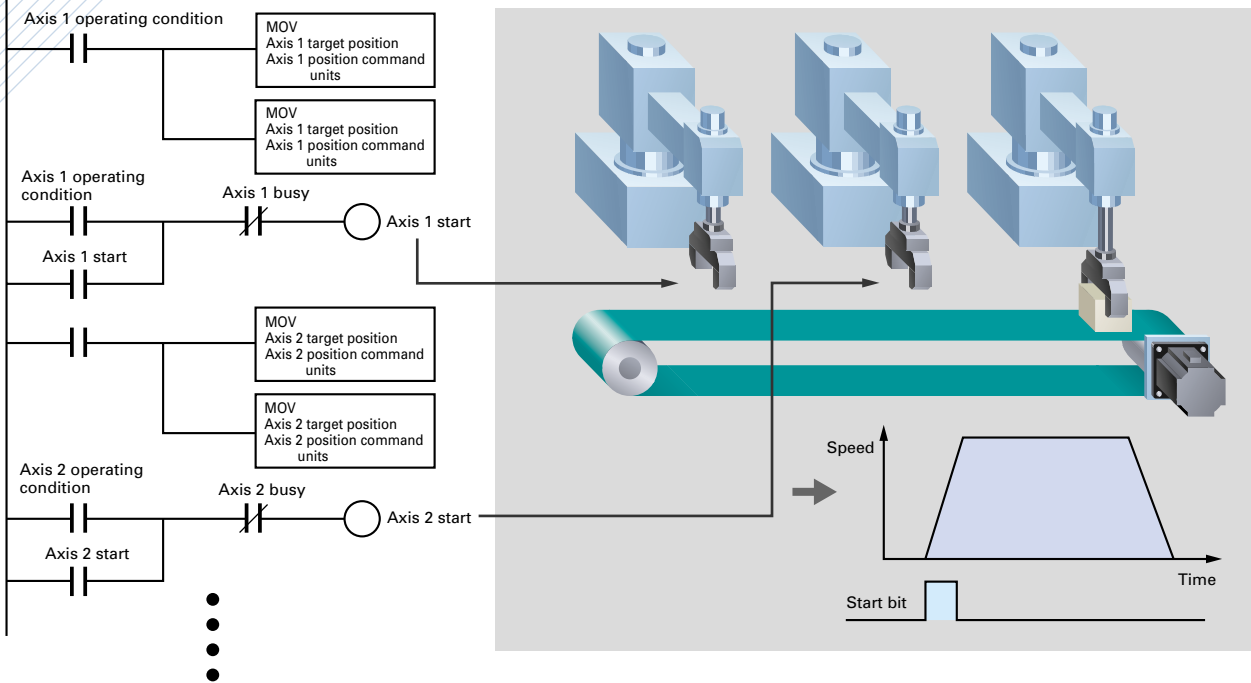

## Feeders

Just as with position control, speed and torque can also be controlled by operating bits directly from the PLC. The position, speed, and torque can be changed while the axis is operating simply by turning ON individual control bits.

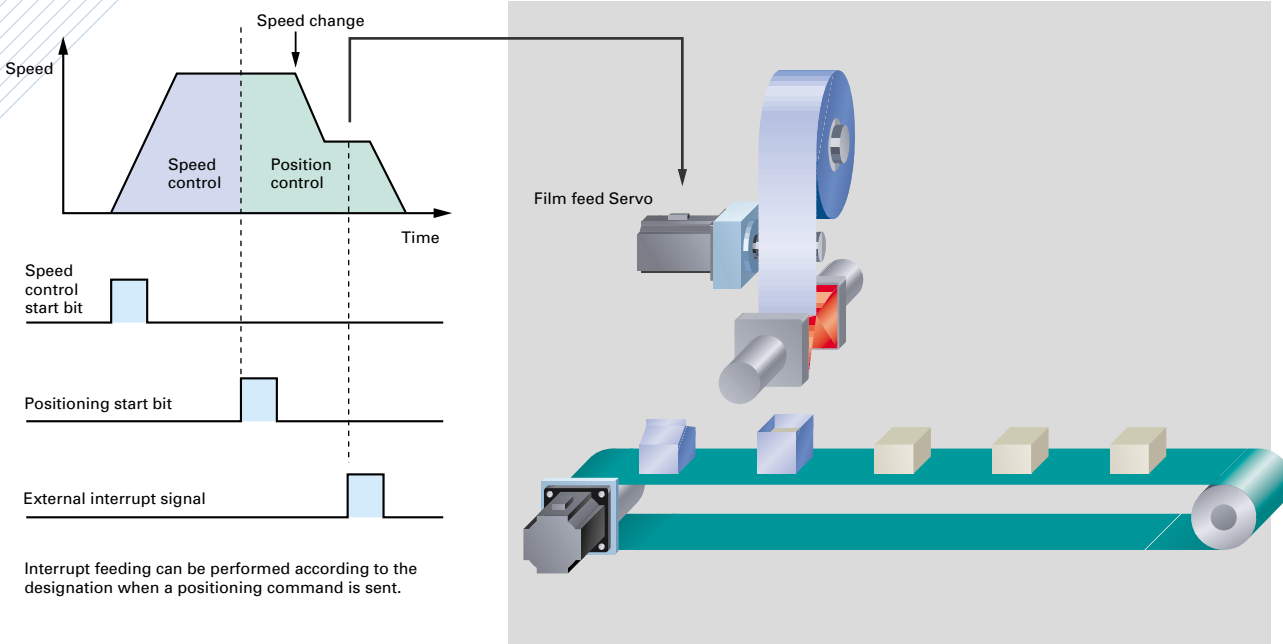

Interrupt feeding can be performed according to the designation when a positioning command is sent.

# Types of Control

## Processing Equipment

Position, speed, and torque can be controlled using a torque limit. The torque limit can be enabled or disabled and a new torque limit can be written while the axis is operating.

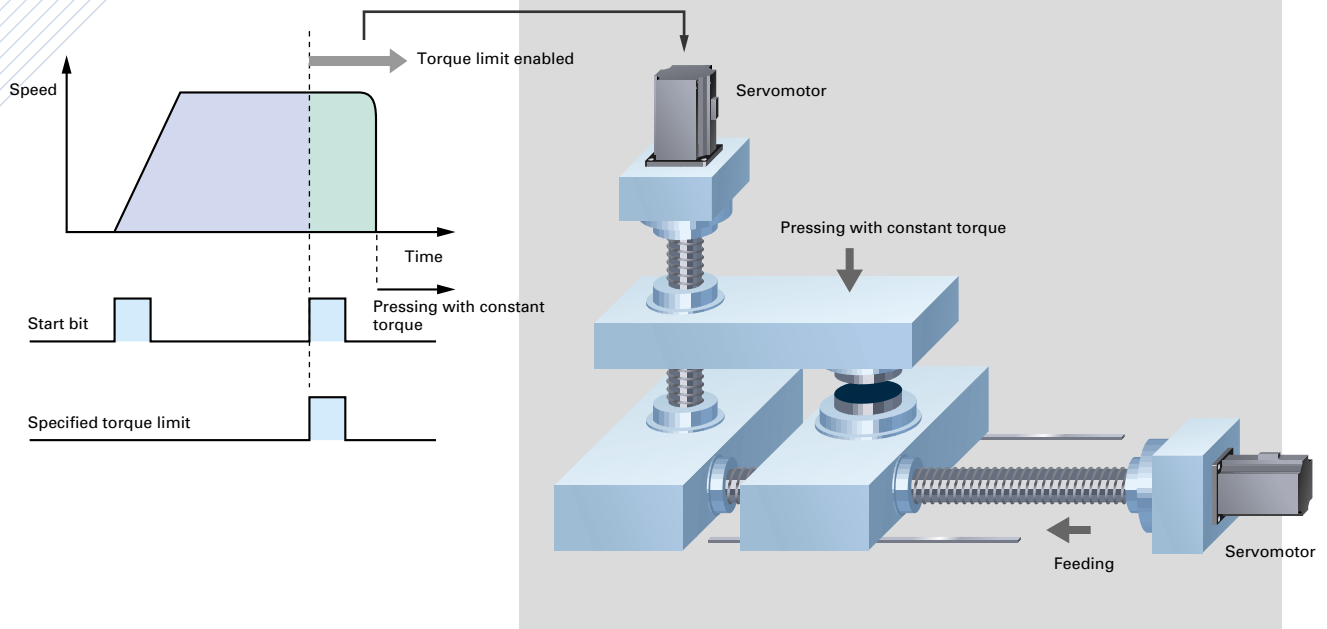

## Conveyors

This example uses a W-series Servomotor with an Absolute Encoder. This eliminates establishing the origin each time the equipment is started up.

Establish the origin and set the offset the first time only.

After that, just turn ON the power to start operation.

This simplifies standby and recovery processing when faults such as a power interruptions occur.

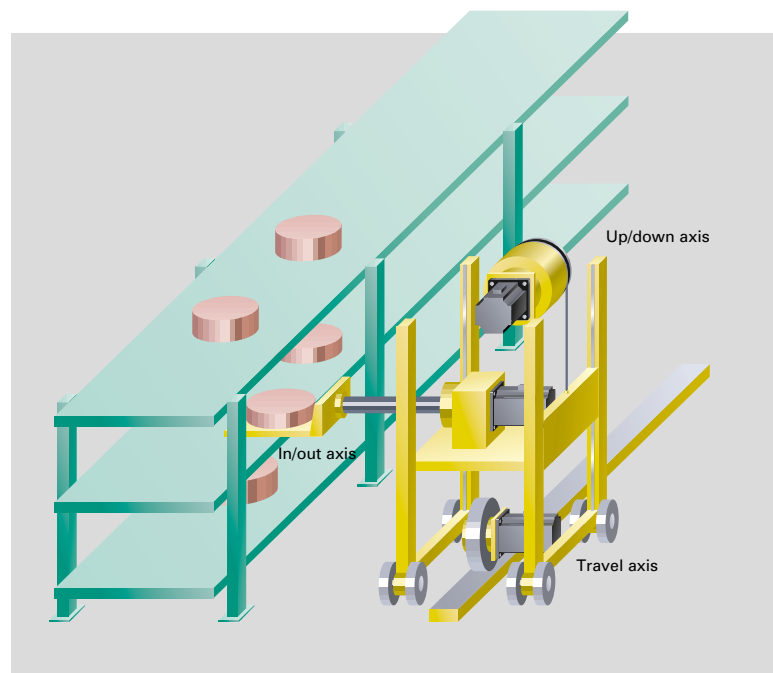

Full advantage can be taken of more advanced Servo Drivers and Servomotors to meet customer needs thanks to motion field network capabilities that include monitoring functions for various Servo Driver status conditions and a wide speed command range.



■ System Configuration Examples



The Support Software for the NCF71 allows all parameters, including Servo Driver parameters, to be sent at one time.

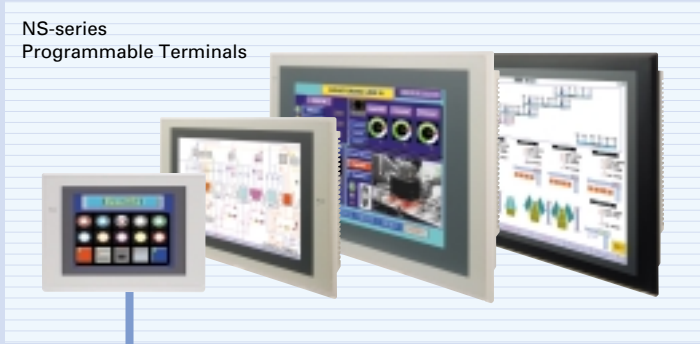

NS-series Programmable Terminals

RS-232C Communications (NT Link)

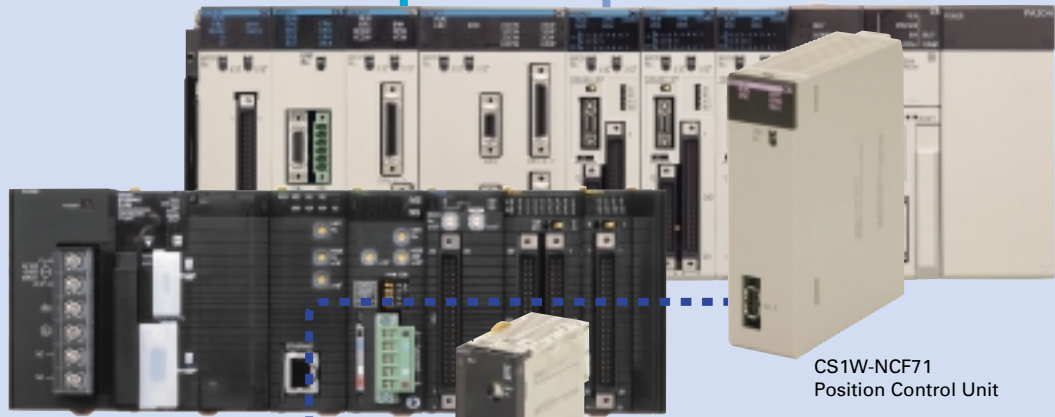

SYSMAC CS/CJ-series Programmable Controller

CS1W-NCF71 Position Control Unit

CJ1W-NCF71 Position Control Unit

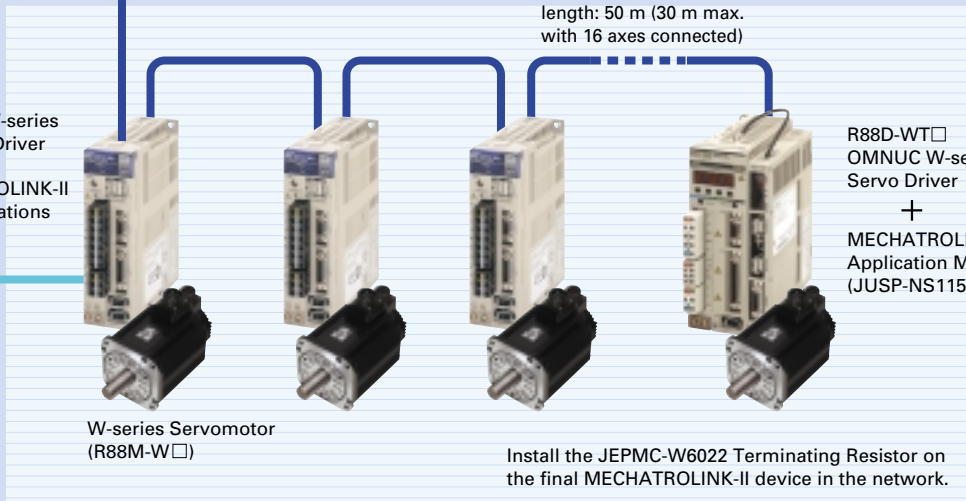

## Ordering Information

Name	Model	Standards
Position Control Unit	CJ1W-NCF71	CE, UL
	CS1W-NCF71	CE, UL

## Related Products

Name	Yaskawa model number	OMRON model number	Remarks
MECHATROLINK-II Application Module	JUSP-NS115	FNY-NS115	—
MECHATROLINK-II Cable	JEPMC-W6003-A5	FNY-W6003-A5	0.5 m
	JEPMC-W6003-01	FNY-W6003-01	1.0 m
	JEPMC-W6003-03	FNY-W6003-03	3.0 m
	JEPMC-W6003-05	FNY-W6003-05	5.0 m
	JEPMC-W6003-10	FNY-W6003-10	10 m
	JEPMC-W6003-20	FNY-W6003-20	20 m
MECHATROLINK-II Terminating Resistor	JEPMC-W6022	FNY-W6022	—

The MECHATROLINK-II Application Module, Cables, and Terminating Resistor (all made by Yaskawa Electric Corporation) can be ordered from OMRON using our model numbers in the table above.

## Support Software

Name	Specification	Model	Standards
CX-One FA Integrated Tool Package version 1.1	The CX-One is an integrated tool package that provides programming and monitoring software for OMRON PLCs and components. The CX-One runs on any of the following operating systems: Windows 98 SE, Me, NT 4.0 (Service Pack 6a), 2000 (Service Pack 3 or higher), or XP The CX-One includes CX-Motion-NCF Ver 1.□. Refer to the CX-One Catalog (R134) for details.	One license	CXONE-AL01C-E
		Three licenses	CXONE-AL03C-E
		Ten licenses	CXONE-AL10C-E
		Thirty licenses	CXONE-AL30C-E
		Fifty licenses	CXONE-AL50C-E
	The CX-Motion-NCF can also be ordered individually using the following model number.		
CX-Motion-NCF Ver. 1.□	Support Software for Position Control Units with MECHATROLINK-II communications. Operating system: Windows 98 SE, Me, NT 4.0 (Service Pack 6a), 2000 (Service Pack 3 or higher), or XP	One license	WS02-MNTC1

Site-licensed products are available for users who will run CX-One on multiple computers. Ask your OMRON sales representative for details.

## Specifications

Item	Specification
Model	CJ1W-NCF71 CS1W-NCF71
Unit classification	CPU Bus Unit
Applicable PLCs	CJ Series CS Series
Unit number settings	0 to F
I/O allocations	Common Operating Memory Area
	Axis Operating Memory Area
Compatible devices	OMRON W-series Servo Drivers equipped with MECHATROLINK-II Application Module
Control method	Control commands executed using MECHATROLINK-II synchronous communications
Maximum number of controlled axes	16 axes
Control commands	Position commands
	Speed commands for position control
	Acceleration/deceleration for position control
	Speed commands for control
	Torque commands for torque control
Control functions	Servo lock/unlock
	Position control
	Establishing the origin
	Jogging
	Interrupt feeding
	Speed control
	Torque control
	Stop functions
	Acceleration/deceleration curves
	Torque limit
	Override
	Servo parameter transfer
	Monitoring function
	Software limits
	Backlash compensation
External I/O	Position Control Unit
	Servo Driver I/O
Self-diagnostic functions	Watchdog, flash memory check, memory corruption check
Error detection functions	Overtravel, Servo Driver alarm detection, CPU error, MECHATROLINK communications error, Unit setting error
Internal current consumption	360 mA max. at 5 V DC 360 mA max. at 5 V DC
Dimensions	31 x 90 x 65 mm (W x H x D) 35 x 130 x 101 mm (W x H x D)
Weight	95 g max. 188 g max.
Ambient operating temperature	0 to 55°C 0 to 55°C

● When a MECHATROLINK-II Application Module must be mounted to a W-series Servo Driver, use the following device versions.

Device	Compatible versions
R88D-WT□ W-series Servo Driver	Version 39 or later
JUSP-NS115 MECHATROLINK-II Application Module	Version □□□03 or later

The versions of both the W-series Servo Driver and MECHATROLINK-II Application Module can be found on the nameplate on the side of each device. If an earlier version of the device is used, it will not function properly. Always use products with versions listed in the table (or later versions).

### CJ1W-NCF71

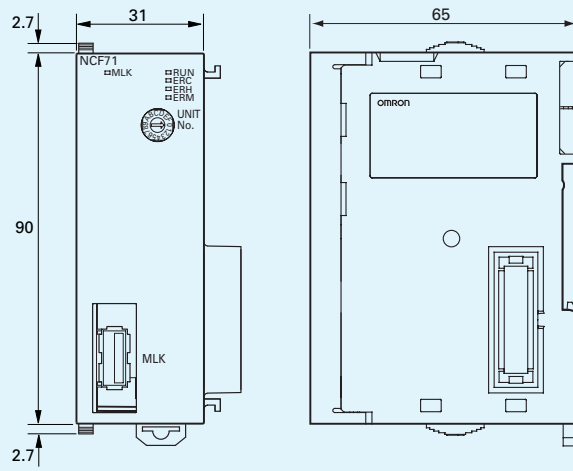

### CS1W-NCF71

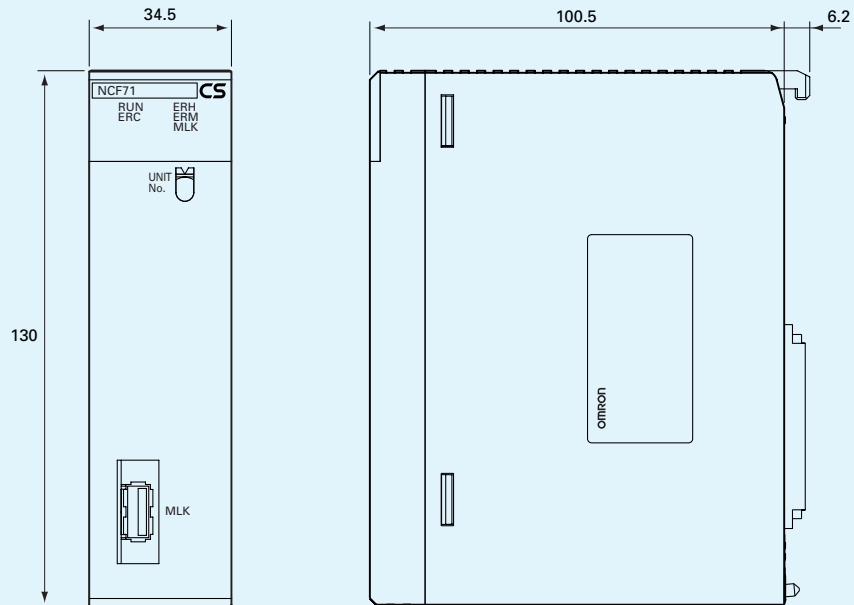



## ■ AC Servo Driver and Servomotor Selection

● The following combinations of Servo Drivers and Servomotors can be connected to Position Control Units.

Combination	Servo Driver	AC Servomotor
①	R88D-WN□□□□-ML2 OMNUC W-series AC Servo Driver supporting MECHATROLINK-II communications	OMNUC W-series AC Servomotor Use a 200-V AC Servomotor for both 100-V and 200-V Servo Drivers.
②	R88D-WT□□□□ OMNUC W-series AC Servo Driver with MECHATROLINK-II Interface Unit	OMNUC W-series AC Servomotor

## ● Servo Driver and Servomotor Combinations

Servomotors R88M- <span style="border: 1px dashed black; padding: 2px;">        </span>						①			②			Application
						R88D-□□-ML2 Servo Drivers with MECHATROLINK-II Communications			Servo Drivers R88D- <span style="border: 1px dashed black; padding: 2px;">        </span>			
Type	Rated speed (maximum number of rotations)	Capacity	International standards CE, UL/cUL	Shaft end (not using decelerator)	Enclosure rating	100 V	200 V single phase	200 V three phase	100 V	200 V single phase	200 V three phase	
Cylinder	3000 r/min (5000 r/min)	30 W	Approved	Straight With key With key and tap Straight with tap	IP55 (excluding shaft opening)	—	—	—	WTA3HL	WTA3H	—	● Low-inertia machines ● Machines with fast tact time <b>Robots</b> <b>Assembly machines</b> <b>Conveyors</b>
		50 W				WNA5L	WNA5H	—	WTA5HL	WTA5H	—	
		100 W				WN01L	WN01H	—	WT01HL	WT01H	—	
		200 W				WN02L	WN02H	—	WT02HL	WT02H	—	
		400 W				WN04L	WN04H	—	—	WT04H	—	
		750 W		—	WN08H	—	—	WT08H*	WT08H			
		1 kW		—	—	WN10H	—	—	WT10H			
		1.5 kW		—	—	WN15H	—	—	WT15H			
		2 kW		—	—	WN20H	—	—	WT20H			
		3 kW		—	—	WN30H	—	—	WT30H			
	4 kW	—	—	—	—	—	WT50H					
	5 kW	—	—	—	—	—	WT50H					
	1500 r/min (3000 r/min)	450 W	Approved	With key and tap Straight	IP67 (excluding shaft opening)	—	—	WN05H	—	—	WT05H	● Machines requiring high torque <b>Simple processing machines</b> <b>Assembly machines</b> <b>Transfer machines</b>
		850 W				—	—	WN10H	—	—	WT10H	
		1.3 kW				—	—	WN15H	—	—	WT15H	
		1.8 kW				—	—	WN20H	—	—	WT20H	
		2.9 kW				—	—	—	—	—	WT30H	
		4.4 kW				—	—	—	—	—	WT50H	
		5.5 kW				—	—	—	—	—	WT60H	
		7.5 kW				—	—	—	—	—	WT75H	
	1500 r/min (2000 r/min)	11 kW	—	—	—	—	—	—	—	WT150H		
		15 kW	—	—	—	—	—	—	—	WT150H		
	1000 r/min (2000 r/min)	300 W	Approved	With key and tap Straight	IP67 (excluding shaft opening)	—	—	WN05H	—	—	WT05H	● Machines requiring high torque <b>Simple processing machines</b> <b>Assembly machines</b> <b>Transfer machines</b>
		600 W				—	—	WN10H	—	—	WT08H	
		900 W				—	—	WN10H	—	—	WT10H	
		1.2 kW				—	—	WN15H	—	—	WT15H	
		2 kW				—	—	WN20H	—	—	WT20H	
		3 kW				—	—	—	—	—	WT30H	
4 kW		—				—	—	—	—	WT50H		
5.5 kW		—				—	—	—	—	WT60H		
Slim profile	100 W	Approved	Straight With key With key and tap Straight with tap	IP55 (excluding shaft opening)	WN01L	WN01H	—	WT01HL	WT01H	—	● Machines with limited motor depth ● Machines requiring water-resistant motors <b>Semiconductor manufacturing machines</b> <b>Food-processing machines</b> <b>AGVs</b>	
	200 W				WN02L	WN02H	—	WT02HL	WT02H	—		
	400 W				WN04L	WN04H	—	—	WT04H	—		
	750 W			—	WN08H	—	—	WT08H*	WT08H			
	1.5 kW			—	—	WN15H	—	—	WT15H			

\*Power supply wiring must be partly changed when using 200-V single-phase Servo Drivers.  
The power supply input specifications are 220 to 230 VAC (+10% to -15%).

## ■ Dimensions of AC Servo Driver with MECHATROLINK-II Communications

### ● AC Servo Drivers

- 200 VAC: 50 W, 100 W or 200 W  
R88D-WNA5H-ML2/WN01H-ML2/WN02H-ML2
- 100 VAC: 50 W, 100 W or 200 W  
R88D-WNA5L-ML2/WN01L-ML2/WN02L-ML2

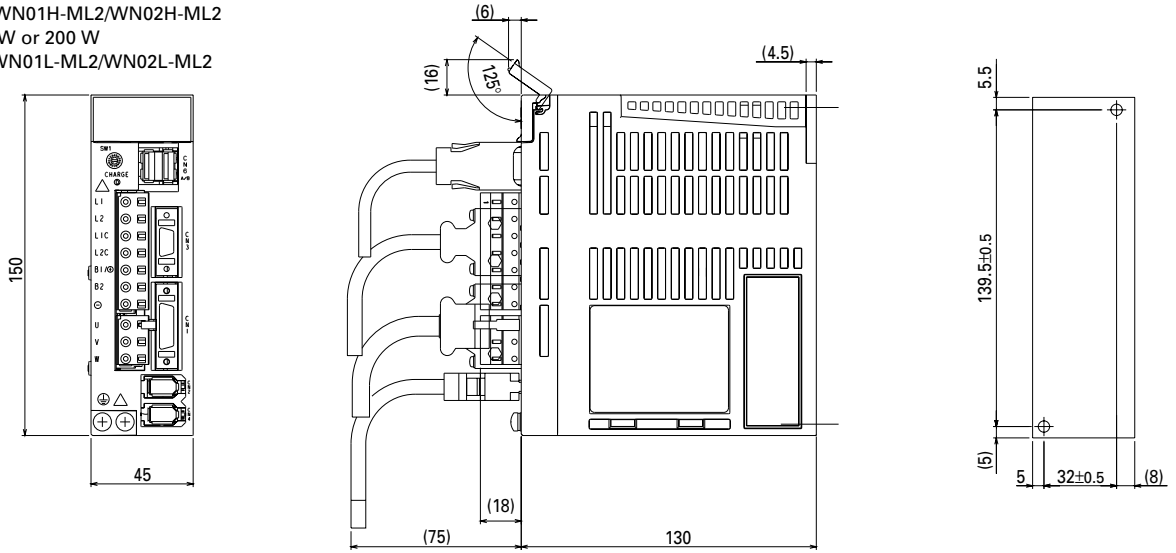

- 200 VAC: 400 W  
R88D-WN04H-ML2

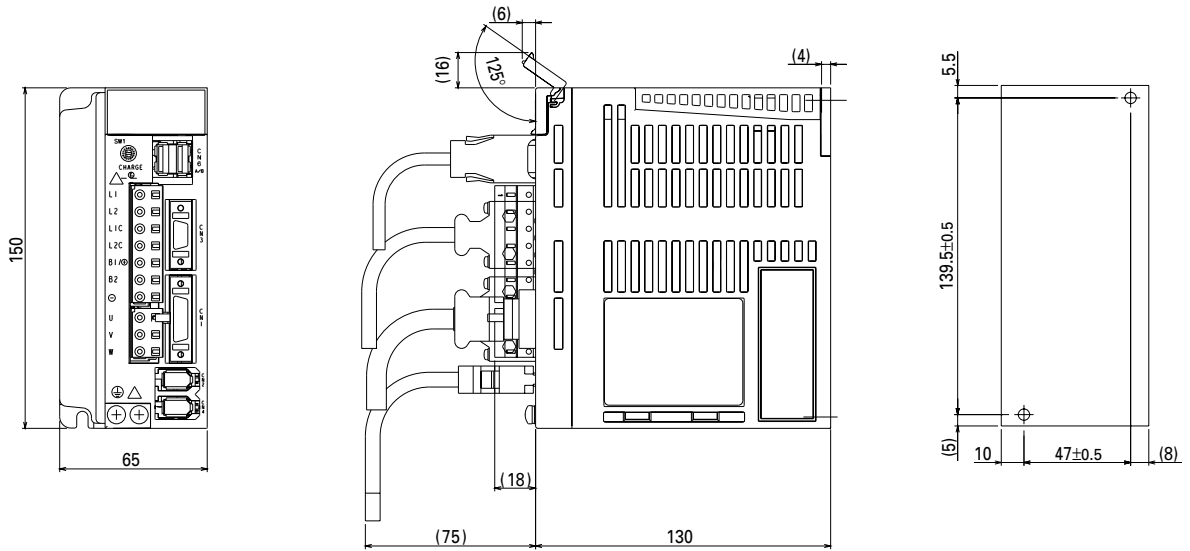

- 100 VAC: 400 W  
R88D-WN04L-ML2

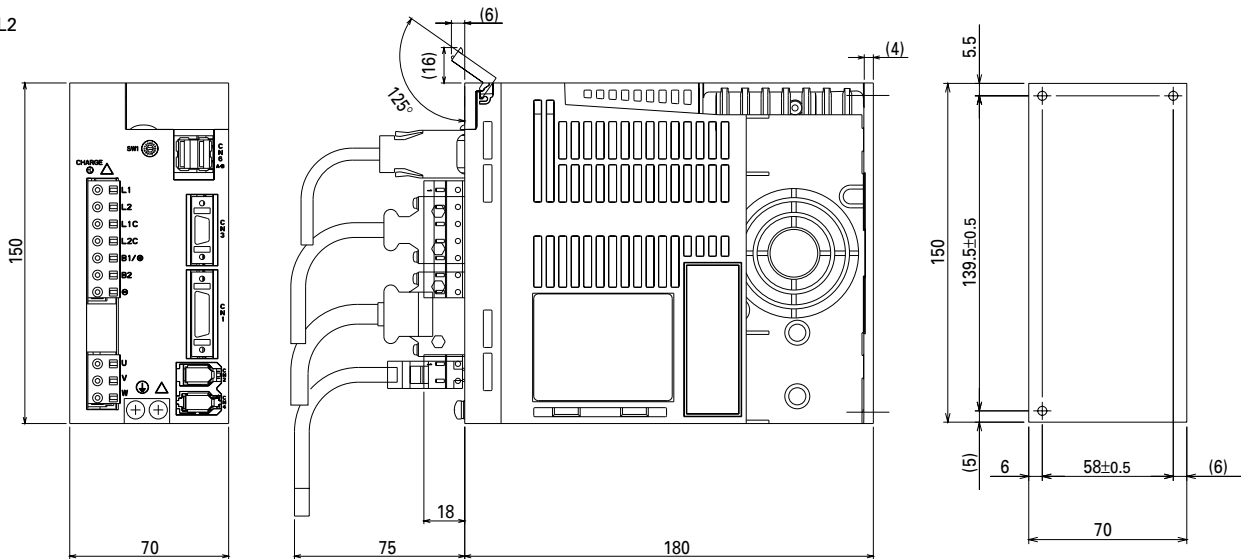

• 200 VAC: 500 W, 750 W or 1 KW  
R88D-WN05H-ML2/WN08H-ML2/WN10H-ML2

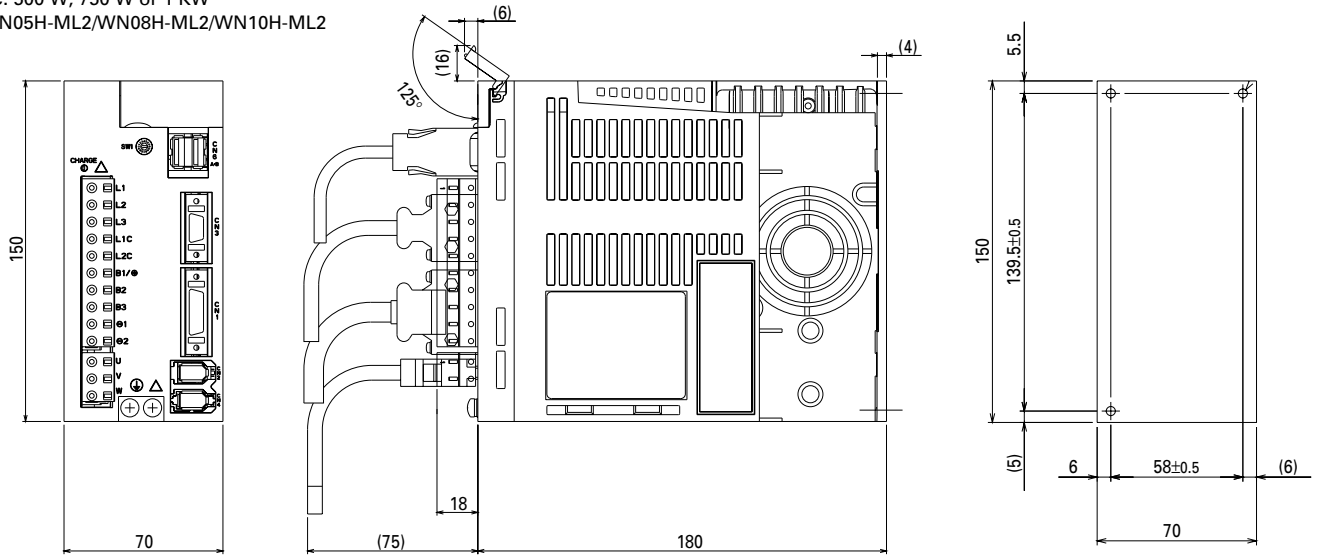

• 200 VAC: 1.5 KW  
R88D-WN15H-ML2

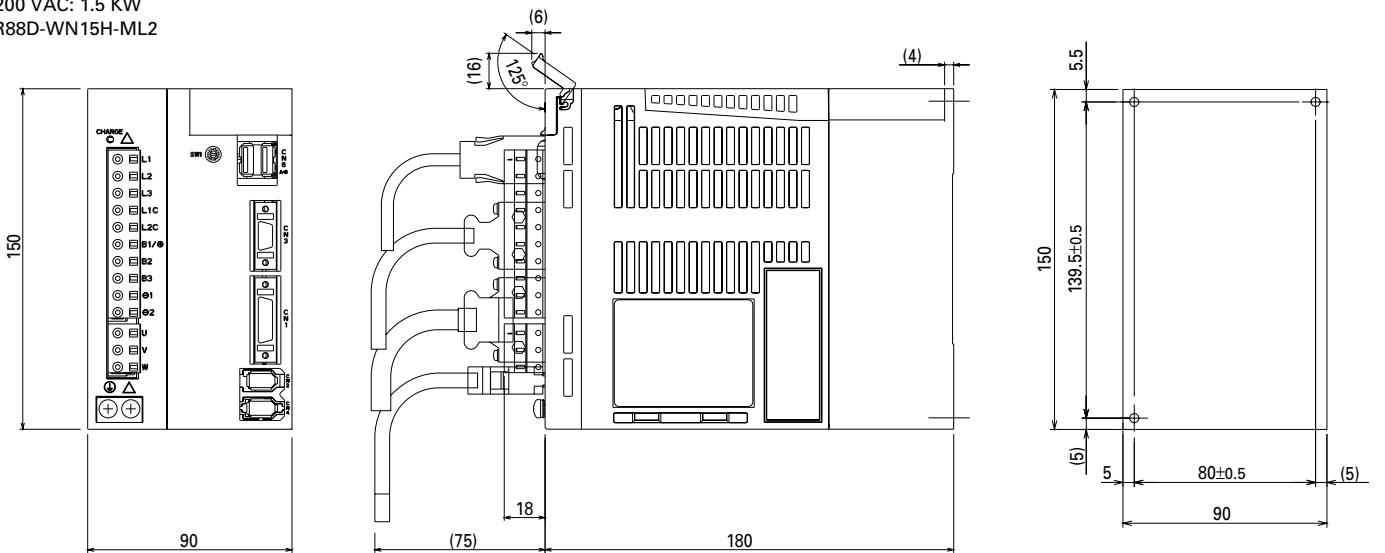

• 200 VAC: 2 KW or 3 KW  
R88D-WN20H-ML2/WN30H-ML2

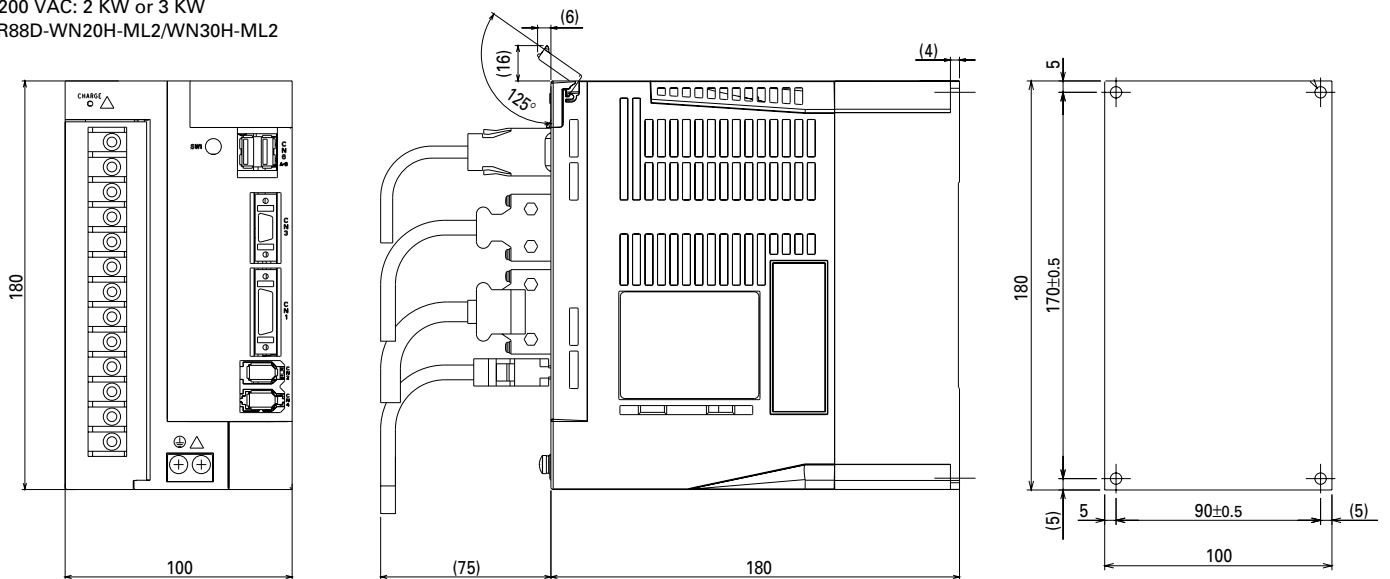

### Warranty and Limitations of Liability

#### WARRANTY

OMRON's exclusive warranty is that the products are free from defects in materials and workmanship for a period of one year (or other period if specified) from date of sale by OMRON.

OMRON MAKES NO WARRANTY OR REPRESENTATION, EXPRESS OR IMPLIED, REGARDING NON-INFRINGEMENT, MERCHANTABILITY, OR FITNESS FOR PARTICULAR PURPOSE OF THE PRODUCTS. ANY BUYER OR USER ACKNOWLEDGES THAT THE BUYER OR USER ALONE HAS DETERMINED THAT THE PRODUCTS WILL SUITABLY MEET THE REQUIREMENTS OF THEIR INTENDED USE. OMRON DISCLAIMS ALL OTHER WARRANTIES, EXPRESS OR IMPLIED.

#### LIMITATIONS OF LIABILITY

OMRON SHALL NOT BE RESPONSIBLE FOR SPECIAL, INDIRECT, OR CONSEQUENTIAL DAMAGES, LOSS OF PROFITS, OR COMMERCIAL LOSS IN ANY WAY CONNECTED WITH THE PRODUCTS, WHETHER SUCH CLAIM IS BASED ON CONTRACT, WARRANTY, NEGLIGENCE, OR STRICT LIABILITY.

In no event shall the responsibility of OMRON for any act exceed the individual price of the product on which liability is asserted.

IN NO EVENT SHALL OMRON BE RESPONSIBLE FOR WARRANTY, REPAIR, OR OTHER CLAIMS REGARDING THE PRODUCTS UNLESS OMRON'S ANALYSIS CONFIRMS THAT THE PRODUCTS WERE PROPERLY HANDLED, STORED, INSTALLED, AND MAINTAINED AND NOT SUBJECT TO CONTAMINATION, ABUSE, MISUSE, OR INAPPROPRIATE MODIFICATION OR REPAIR.

**Note: Do not use this document to operate the Unit.**

Printed on 100%  
Recycled Paper



#### OMRON Corporation

Control Devices Division H.Q.  
Shiokoji Horikawa, Shimogyo-ku,  
Kyoto, 600-8530 Japan  
Tel: (81)75-344-7109  
Fax: (81)75-344-7149

#### Regional Headquarters

OMRON EUROPE B.V.  
Wegalaan 67-69, NL-2132 JD Hoofddorp  
The Netherlands  
Tel: (31)2356-81-300/  
Fax: (31)2356-81-388

#### OMRON ELECTRONICS LLC

1 East Commerce Drive, Schaumburg,  
IL 60173 U.S.A.  
Tel: (1)847-843-7900/Fax: (1)847-843-8568

#### OMRON ASIA PACIFIC PTE. LTD.

83 Clemenceau Avenue,  
#11-01, UE Square,  
Singapore 239920  
Tel: (65)6835-3011/Fax: (65)6835-2711

#### OMRON (CHINA) CO., LTD.

Room 2211, Bank of China Tower,  
200 Yin Cheng Zhong Road,  
PuDong New Area, Shanghai, 200120 China  
Tel: (86)21-5037-2222/Fax: (86)21-5037-2200

Authorized Distributor:

Note: Specifications subject to change without notice.

Cat. No. R118-E1-02  
Printed in Japan  
1205-1M