

SYSMAC
CVM1-PRO01-V1 Teaching Box
with CVM1-MP702-V1 ROM Cassette
(For Motion Control Units)

Operation Manual

Revised August 2002

Notice:

OMRON products are manufactured for use according to proper procedures by a qualified operator and only for the purposes described in this manual.

The following conventions are used to indicate and classify precautions in this manual. Always heed the information provided with them. Failure to heed precautions can result in injury to people or damage to property.

 **DANGER** Indicates an imminently hazardous situation which, if not avoided, will result in death or serious injury.

 **WARNING** Indicates a potentially hazardous situation which, if not avoided, could result in death or serious injury.

 **Caution** Indicates a potentially hazardous situation which, if not avoided, may result in minor or moderate injury, or property damage.

OMRON Product References

All OMRON products are capitalized in this manual. The word “Unit” is also capitalized when it refers to an OMRON product, regardless of whether or not it appears in the proper name of the product.

The abbreviation “Ch,” which appears in some displays and on some OMRON products, often means “word” and is abbreviated “Wd” in documentation in this sense.

The abbreviation “PC” means Programmable Controller and is not used as an abbreviation for anything else.

Visual Aids

The following headings appear in the left column of the manual to help you locate different types of information.

Note Indicates information of particular interest for efficient and convenient operation of the product.

1, 2, 3... 1. Indicates lists of one sort or another, such as procedures, checklists, etc.

© OMRON, 1997

All rights reserved. No part of this publication may be reproduced, stored in a retrieval system, or transmitted, in any form, or by any means, mechanical, electronic, photocopying, recording, or otherwise, without the prior written permission of OMRON.

No patent liability is assumed with respect to the use of the information contained herein. Moreover, because OMRON is constantly striving to improve its high-quality products, the information contained in this manual is subject to change without notice. Every precaution has been taken in the preparation of this manual. Nevertheless, OMRON assumes no responsibility for errors or omissions. Neither is any liability assumed for damages resulting from the use of the information contained in this publication.

TABLE OF CONTENTS

PRECAUTIONS	xi
1 Intended Audience	xii
2 General Precautions	xii
3 Operating Environment Precautions	xii
4 Application Precautions	xiii
SECTION 1	
Introduction	1
1-1 Features and Applications	2
1-2 System Configuration	3
1-3 Table of Operations	7
1-4 Nomenclature and Functions	10
1-5 Precautions When Using the CV500-MC221	12
1-6 Operating Procedure	13
SECTION 2	
MC Unit Operation	15
2-1 Axes and Tasks	16
2-2 MC Unit Control Modes	16
2-3 Restricted Functions	18
SECTION 3	
Connecting the Teaching Box	21
3-1 Connecting to the MC Unit	22
3-2 Installing in a Panel	24
3-3 Selecting the Connected Model	26
3-4 Changing the Display Language (English/Japanese)	27
SECTION 4	
Basic Operations	31
4-1 Initial Operation	32
4-2 Changing the MC Unit Control Mode	33
4-3 Changing the Teaching Box Mode	35
4-4 Direct Functions	35
4-5 Basic Input Operations	36
4-6 Axis and Task Displays	37
4-7 Handling Error Messages	37
4-8 Table of Operations	39
SECTION 5	
MONITOR Mode Operations	41
5-1 MONITOR Mode	42
5-2 Monitoring the Present Position	43
5-3 Monitoring and Changing I/O Signals	44
5-4 Error Data Displays	46
5-5 Monitoring and Changing Position Data	47
5-6 Monitoring the Z-Phase Tolerance	48
5-7 Monitoring and Changing Servo Parameters	49
SECTION 6	
Origin Searches, Program Execution, Jogging, and MPG	53
6-1 Origin Search	54
6-2 Program Execution	55
6-3 Jogging	57
6-4 Handle Feeding	58

TABLE OF CONTENTS

SECTION 7	
EXTENSION Mode Operations	61
7-1 EXTENSION Mode	62
7-2 Servo-lock/Unlock	63
7-3 Memory Protect/Release	65
7-4 Initial Setting of the Absolute Encoder	65
7-5 Software Reset of the Absolute Encoder	67
7-6 Origin Setting of the Absolute Encoder	68
7-7 Switching the Message Display (CS1W-MC221/421 Only)	69
7-8 Saving Data	70
SECTION 8	
Direct Functions	73
8-1 Changing the Override Value	74
8-2 Teaching	75
SECTION 9	
Other Operations	77
9-1 Deceleration Stop	78
9-2 Error Resetting	78
Appendices	
A Standard Models	81
B Error Displays and Error Processing	83
C Specifications and External Dimensions	85
Index	87
Revision History	89

About this Manual:

This manual describes the installation and operation of the CVM1-PRO01-V1 Teaching Box and includes the sections described below. In particular it describes the operation of the Teaching Box when it is connected to a Motion Control Unit. The CVM1-PRO01-V1 Teaching Box is a Programming Device for CS1-series PCs and C/CV-series PCs and is used with the CV500-MC221, CV500-MC421, C200H-MC221, CS1W-MC221, and CS1W-MC421 Motion Control Units.

Please read this manual carefully along with the operation manuals for the CV500-MC221, CV500-MC421, C200H-MC221, CS1W-MC221, and CS1W-MC421 Motion Control Units, and be sure you understand the information provided before attempting to install and operate the Teaching Box.

There are five manuals, excluding this one, used with the CV500-MC221, CV500-MC421, C200H-MC221, CS1W-MC221, and CS1W-MC421 Motion Control Units (MC Units). These manuals are listed in the following table. The suffixes have been left off of the catalog numbers. Be sure you are using the most recent version for your area.

Name	Content	Cat. No.
CS1W-MC221/MC421 Motion Control Unit Operation Manual	Describes the features, applications, and basic operation of the CS1-series Motion Control Units. Read this manual first before using a Motion Control Unit.	W359
CV500-MC221/MC421 Motion Control Unit Operation Manual: Introduction	Describes the features, applications, and basic operation of the CV-series Motion Control Units. Read this manual first before using a Motion Control Unit.	W254
CV500-MC221/MC421 Motion Control Unit Operation Manual: Details	Describes the operation of the CV-series Motion Control Units in detail. Read the <i>Operation Manual: Introduction</i> , above, before attempting to read this manual.	W255
C200H-MC221 Motion Control Unit Operation Manual: Introduction	Describes the features, applications, and basic operation of the C200H Motion Control Unit. Read this manual first before using a Motion Control Unit.	W314
C200H-MC221 Motion Control Unit Operation Manual: Details	Describes operation of the Motion Control Unit in detail. Read the <i>Operation Manual: Introduction</i> , above, before attempting to read this manual.	W315

 **WARNING** Failure to read and understand the information provided in this manual may result in personal injury or death, damage to the product, or product failure. Please read each section in its entirety and be sure you understand the information provided in the section and related sections before attempting any of the procedures or operations given.

Section 1 contains information on the Teaching Box functions and a list of key names and their functions.

Section 2 explains the operating principles, ways of delivering instructions, Motion Control Unit modes, and the operations that can be performed using the Teaching Box. Be sure that you understand all of the subjects covered in this section before attempting any actual operations.

Section 3 describes the procedures for connecting the Teaching Box, installing it on in a control panel, and changing displays.

Section 4 contains information on the basic operations necessary for operating the Teaching Box. Be sure to read this section to fully understand the basic operations before reading detailed descriptions of each function given in subsequent sections.

Section 5 describes the methods for monitoring the various kinds of data. The procedure described in the first subsection is required for monitoring any type of data. Read the first subsection before reading any other subsection.

Section 6 provides information on procedures for origin searches, program execution, jogging, and handle feeding operations. Execute these operations only after locking the servo for the axis to be moved.

Section 7 explains how to change operation modes, how to use operations involving servo-lock and servo-free, memory protection, and operations for absolute encoders. Before attempting any of these operations, be sure to read the material covered in *7-1 EXTENSION Mode*.

Section 8 describes procedures for changing the override value and for teaching.

Section 9 explains how to execute deceleration stops and reset errors.

Appendix A provides a list of standard models.

Appendix B provides tables showing the error code displays, causes of errors, and possible remedies. Refer to this appendix when an error occurs. "PC" stands for "Programmable Controller" and "MC Unit" stands for "Motion Control Unit."

Appendix C provides specifications and external dimensions.

PRECAUTIONS

This section provides general precautions for using the Programmable Controller (PC) and related devices.

The information contained in this section is important for the safe and reliable application of the PC. You must read this section and understand the information contained before attempting to set up or operate a PC system.

1 Intended Audience	xii
2 General Precautions	xii
3 Operating Environment Precautions	xii
4 Application Precautions	xiii

1 Intended Audience

This manual is intended for the following personnel, who must also have knowledge of electrical systems (an electrical engineer or the equivalent).

- Personnel in charge of installing FA systems.
- Personnel in charge of designing FA systems.
- Personnel in charge of managing FA systems and facilities.

2 General Precautions

The user must operate the product according to the performance specifications described in the operation manuals.

Before using the product under conditions which are not described in the manual or applying the product to nuclear control systems, railroad systems, aviation systems, vehicles, combustion systems, medical equipment, amusement machines, safety equipment, and other systems, machines, and equipment that may have a serious influence on lives and property if used improperly, consult your OMRON representative.

Make sure that the ratings and performance characteristics of the product are sufficient for the systems, machines, and equipment, and be sure to provide the systems, machines, and equipment with double safety mechanisms.

This manual provides information for programming and operating OMRON PCs. Be sure to read this manual before attempting to use the software and keep this manual close at hand for reference during operation.

3 Operating Environment Precautions

Install the Teaching Box properly as specified in this manual.

Do not install the Teaching Box in any of the following locations.

- Locations subject to direct sunlight.
- Locations subject to temperatures or humidity outside the range specified in the specifications.
- Locations subject to condensation as the result of severe changes in temperature.
- Locations subject to corrosive or flammable gases.
- Locations subject to dust (especially iron dust) or salts.
- Locations subject to exposure to water, oil, or chemicals.
- Locations subject to shock or vibration.
- Take appropriate and sufficient countermeasures when installing the Teaching Box in the following locations.
 - Locations subject to static electricity or other forms of noise.
 - Locations subject to strong electromagnetic fields.
 - Locations subject to possible exposure to radioactivity.
 - Locations close to power supplies.

4 Application Precautions

Observe the following precautions when using MC Unit, PCU, Teaching Box, or PC.

 **WARNING** Do not attempt to take the Unit apart while the power is being supplied. Doing so may result in electric shock.

 **WARNING** Do not touch any of the terminals while the power is being supplied. Doing so may result in electric shock.

 **WARNING** Provide safety measures in external circuits, i.e., not in the Programmable Controller or MC Unit, in order to ensure safety in the system if an abnormality occurs due to malfunction of the PC, MC Unit, or any other external factor affecting the PC operation. Not doing so may result in a serious accident.

- Emergency stop circuits, interlock circuits, limit circuits, and similar safety measures must be provided in external control circuits.
- The PC will turn OFF all outputs when its self-diagnosis function detects any error or when a severe failure alarm (FALS) instruction is executed. As a countermeasure for such errors, external safety measures must be provided to ensure safety in the system.
- The PC outputs may remain ON or OFF due to deposition or burning of the output relays or destruction of the output transistors. As a countermeasure for such problems, external safety measures must be provided to ensure safety in the system.
- When the 24-VDC output (service power supply to the PC) is overloaded or short-circuited, the voltage may drop and result in the outputs being turned OFF. As a countermeasure for such problems, external safety measures must be provided to ensure safety in the system.
- The system may operate unexpectedly when connectors for the MC Unit are connected or disconnected from the Teaching Box, MPG, I/O, or Servodriver. As a countermeasure for such problems, external safety measures must be provided to ensure safety in the system.

 **Caution** Do not change the message display language (Japanese/English) during memory operation or while the motor is running. Doing so may result in unexpected operation.

 **Caution** The following precautions are necessary to ensure the general safety of the system. Always heed these precautions.

- Mount the Units after confirming that the connectors are properly connected.
- Always use the power supply voltage specified in this manual.
- Take appropriate measures to ensure that the specified power with the rated voltage and frequency is supplied, particularly in places where the power supply is unstable.
- Always connect to a ground of 100 Ω or less when installing the Units.
- Be sure that the terminal blocks, Memory Units, expansion cables, and other items with locking devices are properly locked into place.
- Double-check all the wiring before turning ON the power supply.
- Before touching a Unit, be sure to first touch a grounded metallic object in order to discharge any static built-up.

- Disconnect the functional ground terminal when performing withstand voltage tests.
- Be sure to confirm that no adverse effect will occur in the equipment before executing Jog, Origin Search, Error Resetting, or Deceleration Stop.
- Be sure to confirm that no adverse effect will occur in the equipment before changing the operation mode of the Teaching Box.
- Be sure to confirm that no adverse effect will occur in the equipment before changing the present value.
- Be sure to confirm that no adverse effect will occur in the equipment before changing the set value.
- Be sure to confirm that the set parameter or data operates properly.
- Be sure to confirm that no adverse effect will occur in the equipment before executing the forced set/reset.
- Be sure to rewrite the flash memory after changing the position data or parameters.
- Do not turn OFF the power supply to the Unit while the flash memory is being written. In the worst case, the flash memory may malfunction.
- Be sure to confirm that system parameters operate properly.
- Always turn OFF the power supply before mounting or dismounting Memory Cassettes.
- Do not attempt to disassemble, repair, or modify any Units.
- Do not damage, pull on, apply excessive stresses to, place heavy objects on, or pinch the cables.
- Do not pull on cables when transporting the Units.

SECTION 1

Introduction

This section contains information on the Teaching Box functions and a list of key names and their functions.

If using the Teaching Box for the first time, be sure to familiarize yourself with this section before attempting to operate the Teaching Box.

1-1	Features and Applications	2
1-2	System Configuration	3
1-3	Table of Operations	7
1-4	Nomenclature and Functions	10
1-5	Precautions When Using the CV500-MC221	12
1-6	Operating Procedure	13

1-1 Features and Applications

Features

The CVM1-PRO01-V1 Teaching Box has the following features.

Compatibility

The Teaching Box can be used with MC Units, Position Control Units, and Position Drivers. Either an MC Unit or a Position Control Unit can be connected, depending on the type of Position Control Unit that is selected. In this section, operations are explained in the context of connection to a Position Control Unit.

Detailed Displays

The status of all axes (four axes when the CV500-MC421/221 or CS1W-MC421/221 is connected and two axes when the C200H-MC221 is connected) can be seen at a glance from the message displays (16 characters x 4 lines).

Interactive Operation

Interactive operation allows even those who use the Teaching Box for the first time to use it with ease through key inputs from menus.

Error Messages

Error messages are displayed when errors occur in the Position Control Unit or in the servodriver. These error messages help minimize the scale of problems caused by the error.

Applications

The Teaching Box is mainly used for the following purposes.

- Wiring check
- Monitoring operation via program execution
- Checking movement during feeding operations
- Creating position data through feeding operations and teaching

When feeding operations are performed using a manual pulse generator or jogging operations from the PC, the Teaching Box is mainly used for monitoring the current position.

1-2 System Configuration

Teaching Box Connection

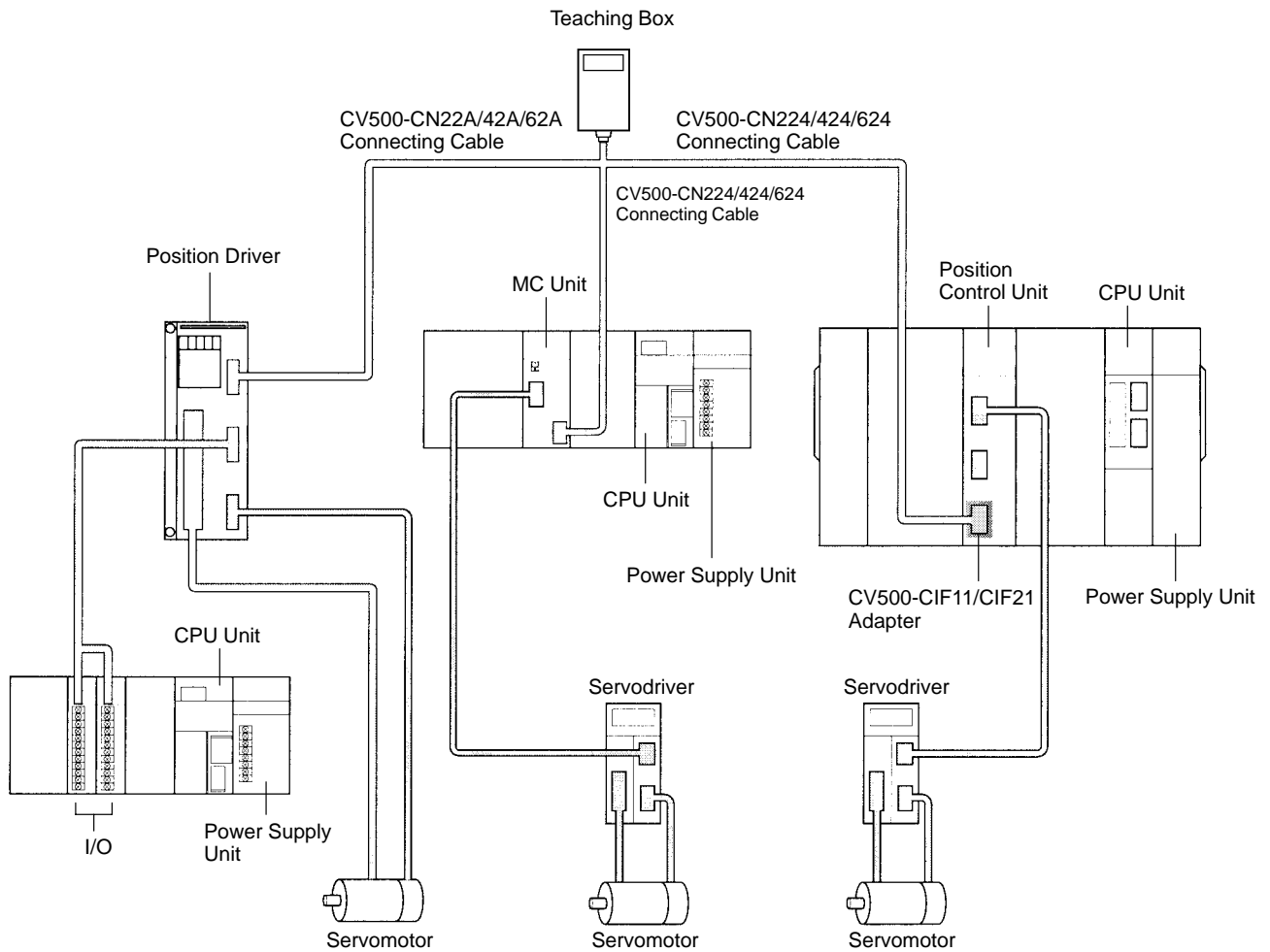

Note Only one Teaching Box can be connected to a Unit. It cannot be connected to more than one Unit.

CS1-series MC Unit Connection

The following example is for the CS1W-MC421.

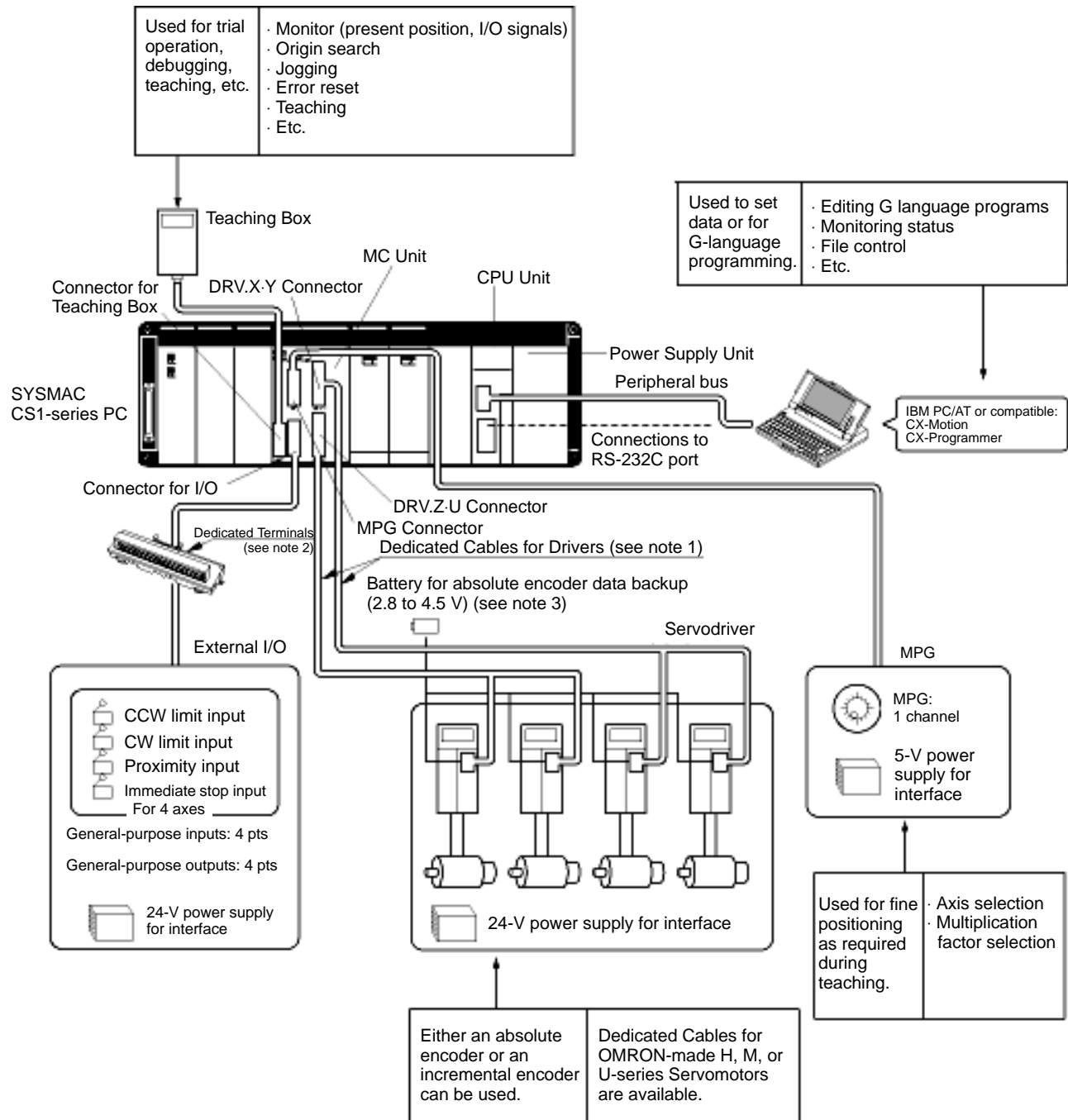

- Note**
1. Dedicated Cables compatible with OMRON H, M, or U-series Servomotors are available. The user can also provide their own cables.
 2. A Dedicated Cable for connections to the Dedicated Terminals is available. The user can also provide their own cable.
 3. A data backup battery must be used when using an absolute encoder.

CV-series MC Unit Connection

The following example is for the CV500-MC421.

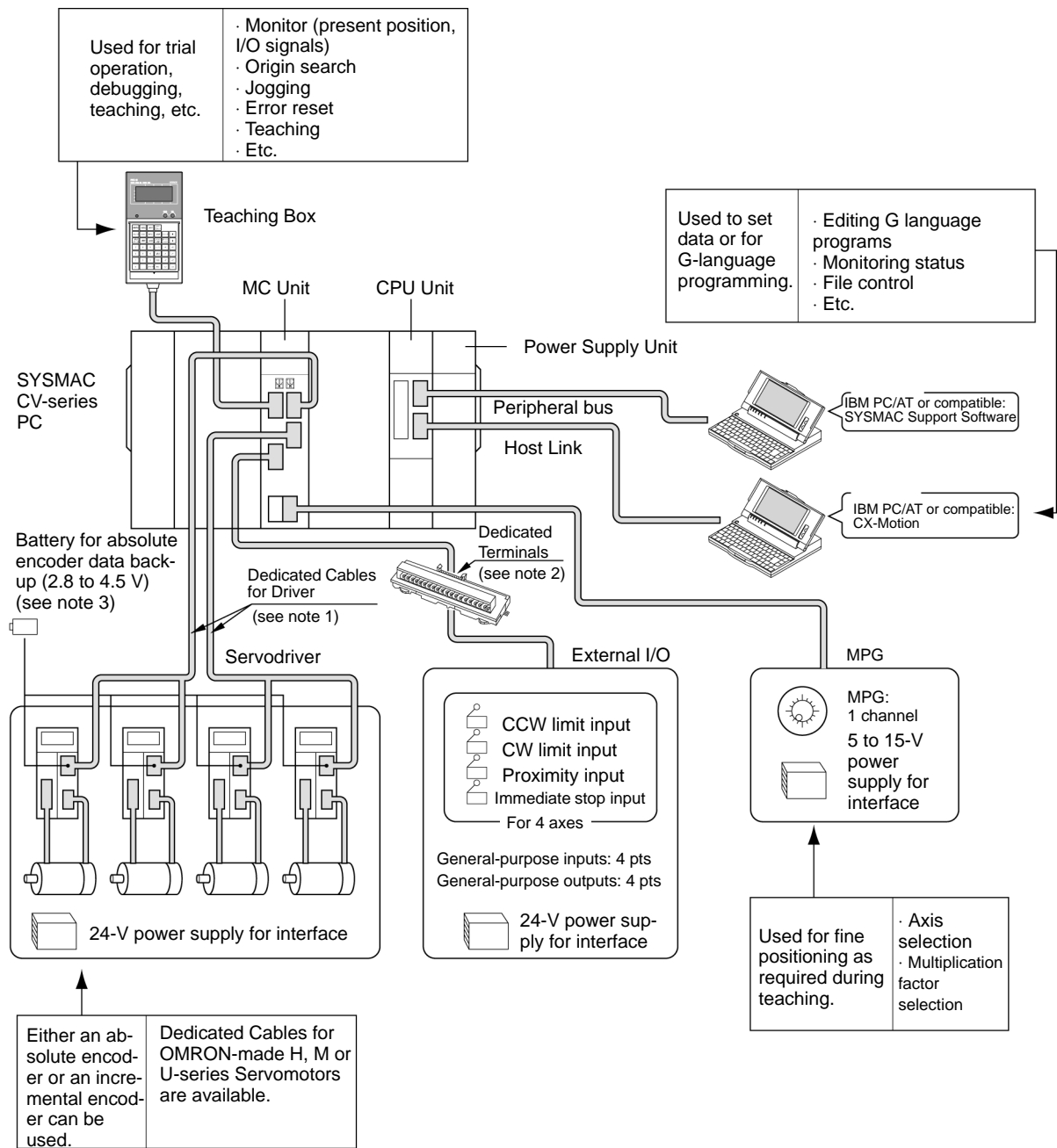

- Note**
1. Dedicated Cables compatible with OMRON H, M, or U-series Servomotors are available. The user can also provide their own cables.
 2. A Dedicated Cable for connections to the Dedicated Terminals is available. The user can also provide their own cable.
 3. A data backup battery must be used when using an absolute encoder.

C200H-MC221

The following example shows the system configuration when a C200HZ/HX/HG/HE PC is used. The C200H and C200HS can also be used.

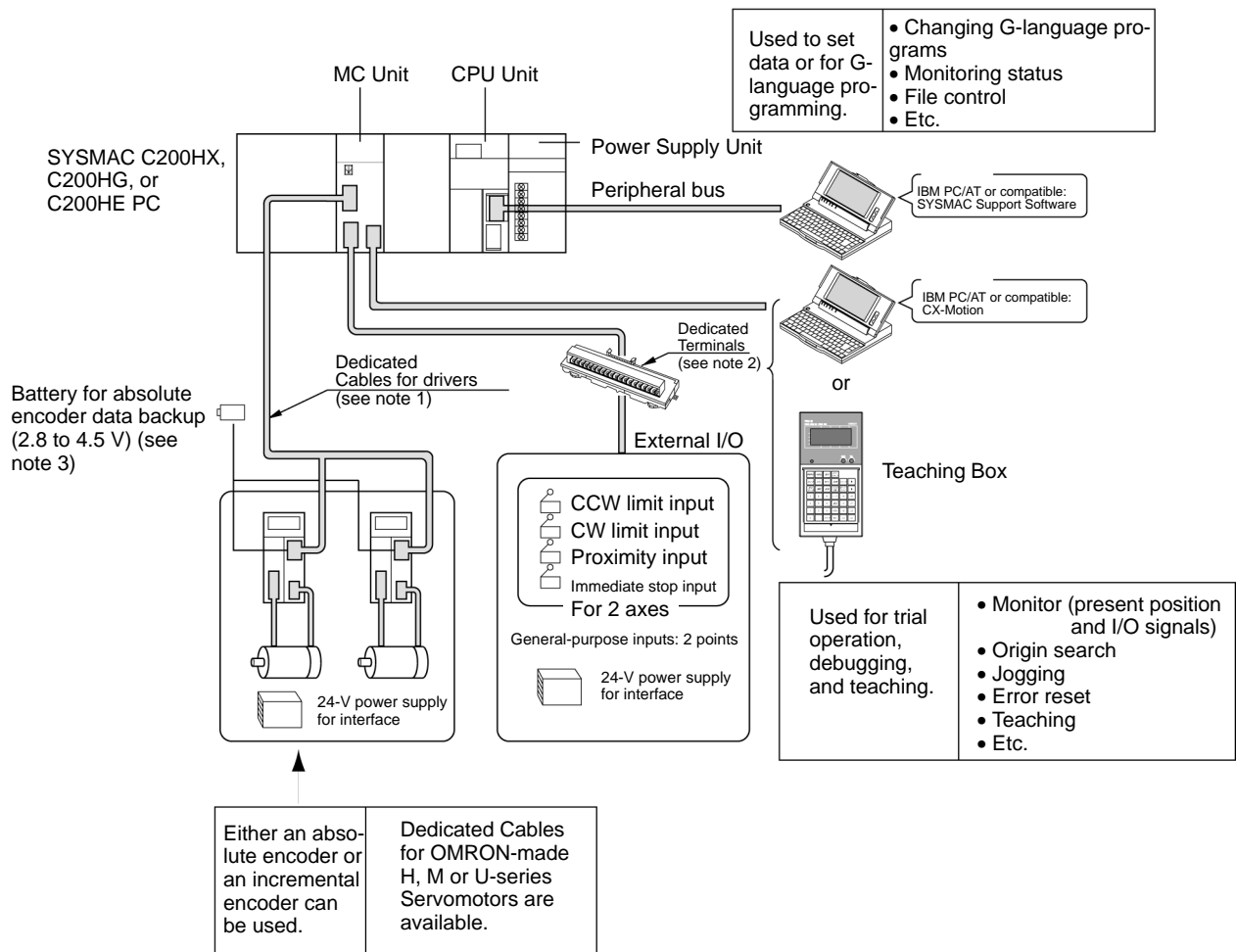

- Note**
1. Dedicated Cables compatible with OMRON H, M, or U-series Servomotors are available. The user can also provide their own cables.
 2. A Dedicated Cable for connections to the Dedicated Terminals is available. The user can also provide their own cable.
 3. A data backup battery must be used when using an absolute encoder.

1-3 Table of Operations

The following tables list the operations of the Teaching Box.

When CS1W-MC221/421 is Used

Function		Description	Page
Monitor	Current position	Monitors the following current positions: Current position in the reference coordinate system (using user-set units such as "mm.") Current position in the reference coordinate system (in pulses.) Error counter value.	43
	I/O signals	Monitors and changes I/O signals connected to the MC Unit.	44
	Errors	Reads errors that have occurred in the MC Unit.	46
	Position data	Reads and changes position data stored in the MC Unit.	47
	Z-phase tolerance	Monitors the number of pulses from the origin input to the Z phase.	48
	Servo parameters	Reads and changes servo parameters.	49
Origin search		Searches for the origin.	54
Program execution	Task/Program No. designation	Designates the desired task and program to be executed.	55
	Cycle run	Executes tasks.	
	Single block run	Executes the program block by block.	
Jogging		Jogs individual axes. More than one axis cannot be jogged at the same time.	57
MPG feeding	Axis	Designates the axis to be fed by MPG (manual pulse generator).	58
	Multiplication factor	Designates the multiplication factor for 1 pulse for the MPG.	
Extension	Mode	Changes the mode used to control the MC Unit.	35
	Servo-lock/ Servo-unlock	Locks or unlocks the servomotor.	63
	Memory protect	Protects or clears protection for memory (position data area) in the MC Unit.	65
	Absolute origin setting	Takes a value of 0 for the mechanical absolute position for the absolute encoder, and establishes an origin. This function is used when replacing an absolute encoder or using an absolute encoder for the first time.	68
	Message switching	Switches the messages displayed by the Teaching Box between English and Japanese.	69
	Saving	Saves system parameters, position data and programs to flash memory.	70
Override		Increases or decreases the operating speed in axis units during memory operation.	74
Teaching		Registers the current position as position data.	75
Deceleration stop		Decelerates all axes to a stop. Stops the currently operating program.	78
Error reset	MC Unit error reset	Resets errors that have occurred in the MC Unit.	78
	Servodriver error reset	Resets alarms for the Servodriver.	
Error detection		CPU errors Communications errors	83

When CV500-MC221/421 is Used

Function		Description	Page
Monitor	Current position	Monitors the following current positions: Current position in the reference coordinate system (using user-set units such as "mm.") Current position in the reference coordinate system (in pulses.) Error counter value.	43
	I/O signals	Monitors and changes I/O signals connected to the MC Unit.	44
	Errors	Reads errors that have occurred in the MC Unit.	46
	Position data	Reads and changes position data stored in the MC Unit.	47
	Z-phase tolerance	Monitors the number of pulses from the origin input to the Z phase.	48
Origin search		Searches for the origin.	54
Program execution	Task/Program No. designation	Designates the desired task and program to be executed.	55
	Cycle run	Executes tasks.	
	Single block run	Executes the program block by block.	
Jogging		Jogs individual axes. More than one axis cannot be jogged at the same time.	57
MPG feeding	Axis	Designates the axis to be fed by MPG (manual pulse generator).	58
	Multiplication factor	Designates the multiplication factor for 1 pulse for the MPG.	
Extension	Mode	Changes the mode used to control the MC Unit.	35
	Servo-lock/ Servo-unlock	Locks or unlocks the servomotor.	63
	Memory protect	Protects or clears protection for memory (position data area) in the MC Unit.	65
	Absolute encoder initial setting	Sets the current position to 0 when using an absolute encoder. This function is used when replacing an absolute encoder or using an absolute encoder for the first time.	65
	Absolute encoder software reset	Tentatively sets the current position to 0 when using the absolute encoder. This function is used for incrementing after the absolute encoder initial setting has been made.	67
Override		Increases or decreased the operating speed in axis units during memory operation.	74
Teaching		Registers the current position as position data.	75
Deceleration stop		Decelerates all axes to a stop. Stops the currently operating program.	78
Error reset	MC Unit error reset	Resets errors that have occurred in the MC Unit.	78
	Servodriver error reset	Resets alarms for the Servodriver.	
Error detection		CPU errors Communications errors	83

When C200H-MC221 is Used

Function		Description	Page
Monitor	Current position	Monitors the following current position: Current position in the reference coordinate system (using user-set unit such as "mm.") Current position in the reference coordinate system (in pulses.) Error counter value.	43
	I/O signals	Monitors and changes I/O signals connected to the MC Unit.	44
	Errors	Reads errors that have occurred in the MC Unit.	46
	Position data	Reads and changes position data stored in the MC Unit.	47
	Z-phase tolerance	Monitors the number of pulses from the origin input to the Z phase.	48
	Servo-parameters	Reads or changes the Servodriver parameters.	49
Origin search		Searches for the origin.	54
Program execution	Task/program No. designation	Designates the desired task and program to be executed.	55
	Cycle run	Executes tasks.	
	Single block run	Executes the program block by block.	
Jogging		Jogs individual axes. More than one axis cannot be jogged at the same time.	57
MPG feeding	Multiplication factor	Designates the multiplication factor for 1 pulse for the MPG.	58
Extension	Mode	Changes the mode used to control the MC Unit.	35
	Servo-lock/ servo-unlock	Locks or unlocks the servomotor.	63
	Memory protect	Protects or clears protection for memory (position data area) in the MC Unit.	65
	Absolute encoder initial setting	Sets the current position to 0 when using an absolute encoder. This function is used when replacing an absolute encoder or using an absolute encoder for the first time.	65
	Absolute encoder software reset	Tentatively sets the current position to 0 when using the absolute encoder. This function is used for incrementing after the absolute encoder initial setting has been made.	67
	Saving	Saves the system parameters, position data, and programs in the flash memory.	70
Override		Increases or decreases the operating speed during memory operation.	74
Teaching		Registers the current position as position data.	75
Deceleration stop		Decelerates all axes to a stop. Stops the currently operating program.	78
Error reset	MC Unit error reset	Resets errors that have occurred in the MC Unit.	78
	Servodriver error reset	Resets alarms for the Servodriver.	
Error detection		CPU errors Communications errors	83

1-4 Nomenclature and Functions

Shown below are the parts, functions, and key arrangement of the Teaching Box.

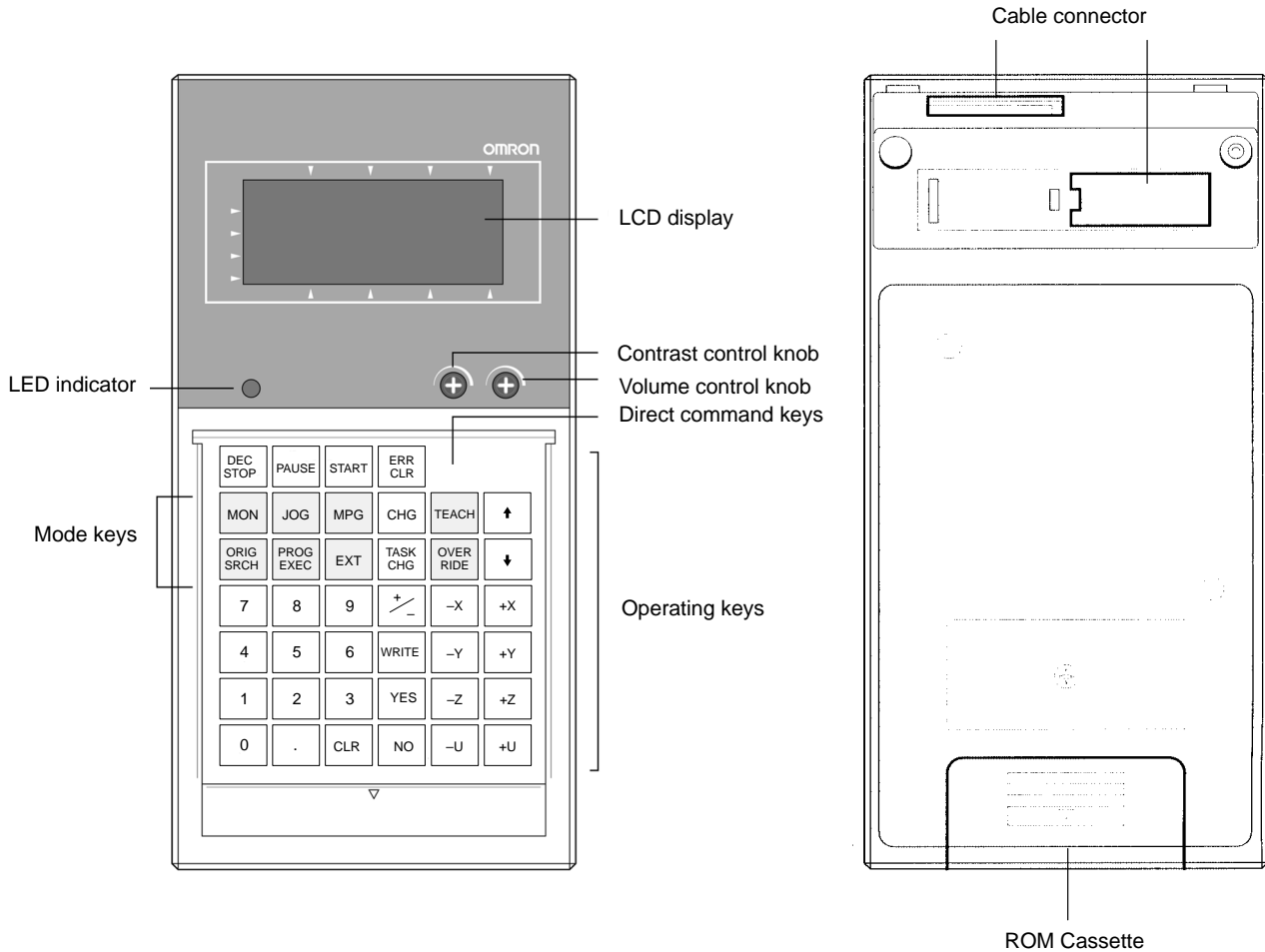

Part	Function
LCD display	Displays various data. Illuminated by LED.
LED indicator	Lit while the CPU of the PC is executing the user program (RUN or MONITOR mode).
Contrast control knob	Used to control the contrast of the LCD display.
Volume control knob	Used to control the buzzer sound produced when an input is made by pressing keys or when an error occurs.
Operating keys	Refer to the following pages.

Operating Key Arrangement

Classification	Function
Mode keys	Used to set the Teaching Box mode.
Direct command keys	Used to give a direct command to immediately execute a specific function in any Teaching Box mode.

Key Functions

Classification	Key	Function
Mode keys	MON	Monitors current position or I/O signals (MONITOR mode).
	ORIG SRCH	Moves the selected axis to the origin (ORIGIN SEARCH mode).
	JOG	Jogs the selected axis (JOG mode).
	MPG	Designates the axis and multiplication factor when using a manual pulse generator (MPG mode).
	PROG EXEC	Executes programs (RUN mode).
	EXT	Sets the control mode for the MC Unit, force-locks/unlocks the servo, etc. (EXTENSION mode).
Direct command keys	OVERRIDE	Increases or decreases the speed of the axis under operation.
	TEACH	Writes the current position of axes as position data.
Other keys	DEC STOP	Decelerates and stops all axis movement. Stopping using the DEC STOP Key is treated as a system error.
	PAUSE	Stops program execution or origin searches. This key is valid only during program execution or origin searches.
	START	Starts positioning.
	ERR CLR	Resets errors to clear the error status of the MC Unit.
	CHG	Enables changing numeral data.
	TASK CHG	Changes the task to be executed in PROGRAM EXECUTION mode.
	Numeric	Used to input numeric data.
	+/-	Used to change the sign (+/-) of numbers. Every press of the key toggles the sign. (+ is not displayed.)
	CLR	Clears data that has been set or returns to the previous display.
	WRITE	Outputs data that has been set or writes it to memory.
	YES, NO	Used when a confirmation display appears.
	↓,↑	Scroll the display up and down.
	Feed keys	Used to jog or handle-feed an axis. These keys are valid only in JOG or MPG mode. These keys are also used to select the servo parameter axis for the CS1W-421/221 and C200H-MC221.

Note The feed keys are +X, -X, +Y, -Y, +Z, -Z, +U and -U. +Z, -Z, +U, and -U are not effective for the CS1W-MC221, CV500-MC221 and C200H-MC221.

1-5 Precautions When Using the CV500-MC221

The operating procedures of the Teaching Box using the CS1W-MC421 MC Unit or the CS1W-MC221 MC Unit are respectively the same as those of the Teaching Box using the CV500-MC421 MC Unit or the CV500-MC221 MC Unit.

Descriptions in this manual are given for the Teaching Box using the CS1W-MC421 or the CV500-MC421. Note the following precautions when using the CV500-MC221.

Item	Precautions
Monitoring	<p>Monitored current data is displayed for all four axes. "0" is displayed for the unsupported axes (Z and U axes).</p> <p>The I/O signals are also displayed for all four axes. The CCW limit input, CW limit input, emergency stop input and alarm input are displayed as "1" for unsupported axes as shown below. (Even when "1" is displayed, the X and Y axis can be operated.)</p> <div style="border: 1px solid black; padding: 5px; margin: 10px 0;"> <pre> MONI XYZU IN IORIG POS**00 ICCW LINT**11 ICW LIMIT**11 </pre> </div> <div style="border: 1px solid black; padding: 5px; margin: 10px 0;"> <pre> MONI XYZU IN IDRUV ALRM**11 ISTOP **11 </pre> </div> <p>*: "0" or "1"</p>
Jog MPG	The +Z, -Z, +U and -U Keys are not supported.
Other functions	All other operations for the Z and U axes are also not supported.

1-6 Operating Procedure

Follow the procedure outlined below to operate axes using the Teaching Box.

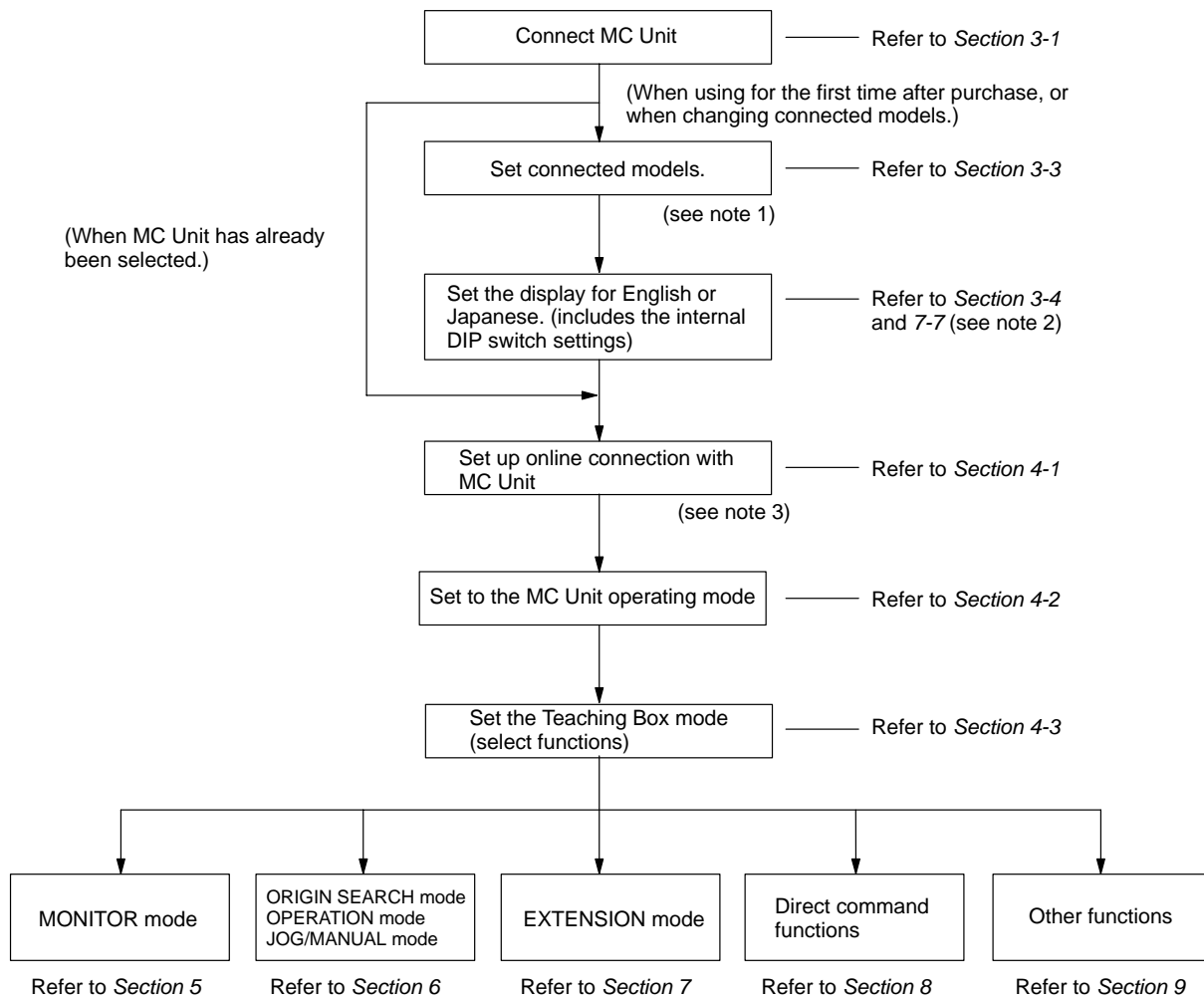

- Note**
1. By turning ON power to the PC while the CLR Key is pressed, the connected models selection screen can be displayed.
 2. With the CS1W-MC421/221, messages can be switched between English and Japanese in EXTENSION mode.
 3. "Online connection" refers to the state in which data can pass back and forth between the MC Unit and the Teaching Box.

SECTION 2

MC Unit Operation

This section explains the operating principles, ways of delivering instructions, Motion Control Unit modes, and the operations that can be performed using the Teaching Box. Be sure that you understand all of the subjects covered in this section before attempting any actual operations.

2-1	Axes and Tasks	16
2-2	MC Unit Control Modes	16
2-3	Restricted Functions	18

2-1 Axes and Tasks

The axes for operation and tasks to be performed are described below.

Motion Control

The basic objects of motion control are the axes. Axes can be controlled either in combination or independently.

Tasks

A task is an executable unit of programming in MC programs.

Up to four tasks can be executed by the MC Unit.

Tasks must be taken into consideration when creating or teaching position data or when executing programs.

Each task is designed to control one or more axes as illustrated by the following example.

Example:

The following example for the CS1W-MC421 or CV500-MC421 shows two tasks designed to control two axes each.

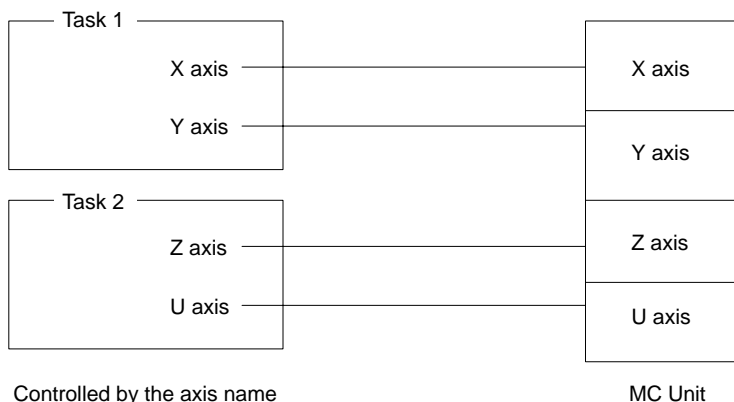

2-2 MC Unit Control Modes

The following section describes the systems and modes used to control the MC Unit.

When the C200H-MC221 is Used

Tasks are controlled through the following three systems: the MC Support Software, ladder-diagram program, and Teaching Box

The MC Unit may be processing commands from any two of these systems at the same time.

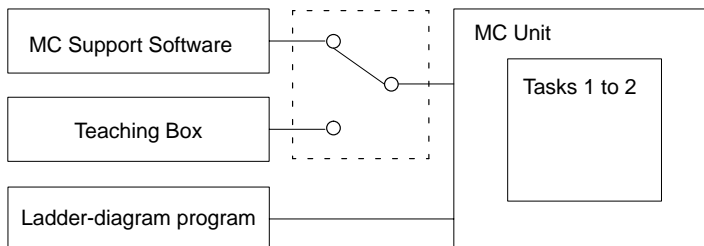

When the CS1W-MC221/421 or CV500-MC221/421 is Used

Tasks are controlled through the following three systems: the CX-Motion, ladder-diagram program, and Teaching Box

The MC Unit may be processing commands from all the three systems at the same time.



MC Unit Control Modes

There are three modes used to control the MC Unit from the Teaching Box. These three control modes are provided to avoid possible problems that may be caused with commands coming from three different control systems and also to assure the user's safety.

- The MC Unit is initially set to the T.BOX LIMITED mode which allows only monitoring from the Teaching Box.
- When executing any function other than monitoring, change the control mode to either T.BOX ENABLED or T.BOX RESERVED.
- Control modes of the MC Unit can be changed only from the Teaching Box.

Refer to 4-2 *Changing the MC Unit Control Mode* for information on changing the control mode.

Control mode	Description
T.BOX LIMITED	Default setting which allows only monitoring from the Teaching Box. This mode is automatically returned to when the power supply to the MC Unit is reset or when the Teaching Box is disconnected and reconnected. Normally used for monitoring the current position.
T.BOX ENABLED	Used to execute programs (debugging), teaching, and perform other operations from the Teaching Box. When the MC Unit is set for this control mode, only the following operations are possible from the ladder-diagram program (cyclic). Deceleration stop (for interlocking while jogging) Optional switches (for debugging during program execution) Resetting M codes (for debugging during program execution)
T.BOX RESERVED	All commands (cyclic) from the ladder-diagram program are ignored. This mode is used when performing wiring checks or when teaching. When programs are executed in this mode, those functions that are interfaced with external devices, such as waiting for M code resets or optional inputs, are ignored. The only difference between this mode and the T.BOX ENABLED mode is that in this mode, all commands from the ladder-diagram program are ignored.

“T.BOX” stands for the Teaching Box and is used in Teaching Box displays.

Note The setting of the Error Counter Selection Bit in the PC Interface Area (word n, bit 07) made from the ladder program is valid for the CS1W-MC421/221 regardless of the operating mode of the Teaching Box.

2-3 Restricted Functions

Some Teaching Box functions are restricted depending on the control mode of the MC Unit.

The following tables show which functions are valid for each control mode.

CS1W-MC221/421

Function		Control mode		
		T.BOX LIMITED	T.BOX ENABLED	T.BOX RESERVED
Monitoring	Current position	OK	OK	OK
	I/O signals	See note 1	OK	OK
	Error data	OK	OK	OK
	Position data	See note 2	OK	OK
	Z-phase tolerance	OK	OK	OK
	Servo parameters	OK	OK	OK
Origin searches		No	OK	OK
Program execution		No	OK	OK
Jogging		No	OK	OK
MPG (handle feeding)		No	OK	OK
Extension	Change mode	OK	OK	OK
	Servo-lock/ Servo-unlock	No	OK	OK
	Memory protection	No	OK	OK
	Absolute origin setting	No	OK	OK
	Message switching	OK	OK	OK
	Saving	No	OK	OK
Override		See note 3	OK	OK
Teaching		No	OK	OK
Deceleration stop		No	OK	OK
Error reset		No	OK	OK

- Note**
1. Only monitoring of the ON/OFF status of output signals and monitoring of analog output data is possible. No changes can be made.
 2. Only monitoring of position data is possible. No changes can be made.
 3. Only the override value can be monitored. No changes can be made.

CV500-MC221/421

Function		Control mode		
		T.BOX LIMITED	T.BOX ENABLED	T.BOX RESERVED
Monitoring	Current position	OK	OK	OK
	I/O signals	See note 2	OK	OK
	Error data	OK	OK	OK
	Position data	OK	OK	OK
	Z-phase tolerance	OK	OK	OK
Origin searches		No	OK	OK
Program execution		No	OK	OK
Jogging		No	OK	OK
MPG (handle feeding)		No	OK	OK
Extension	Change mode	OK	OK	OK
	Servo-lock/ Servo-unlock	No	OK	OK
	Memory protection	No	OK	OK
	Absolute encoder initial setting	No	OK	OK
	Absolute encoder software reset	No	OK	OK
Override		See note 1	OK	OK
Teaching		No	OK	OK
Deceleration stop		No	OK	OK
Error reset		No	OK	OK

- Note**
1. Only the override value can be monitored. No changes can be made.
 2. Only monitoring of the ON/OFF status of output signals and monitoring of analog output data is possible. No changes can be made.

C200H-MC221

Function		Control mode		
		T.BOX LIMITED	T.BOX ENABLED	T.BOX RESERVED
Monitoring	Present position	OK	OK	OK
	I/O signals	See note 2	OK	OK
	Error data	OK	OK	OK
	Position data	See note 3	OK	OK
	Z-phase tolerance	OK	OK	OK
	Servo-parameters	OK	OK	OK
Origin searches		No	OK	OK
Program execution		No	OK	OK
Jogging		No	OK	OK
MPG (handle feeding)		No	OK	OK
Extension	Change mode	OK	OK	OK
	Servo-lock/ Servo-unlock	No	OK	OK
	Memory protection	No	OK	OK
	Absolute encoder initial setting	No	OK	OK
	Absolute encoder soft reset	No	OK	OK
	Saving	No	OK	OK
Override		See note 1	OK	OK
Teaching		No	OK	OK
Deceleration stop		No	OK	OK
Error reset		No	OK	OK

- Note**
1. Only the override value can be monitored. No changes can be made.
 2. Only monitoring of the ON/OFF status of output signals and monitoring of analog output data is possible. No changes can be made.
 3. Only monitors the position data. No changes can be made.

SECTION 3

Connecting the Teaching Box

This section describes the procedures for connecting the Teaching Box, installing it on in a control panel, and changing displays.

3-1	Connecting to the MC Unit	22
3-2	Installing in a Panel	24
3-3	Selecting the Connected Model	26
3-4	Changing the Display Language (English/Japanese)	27

3-1 Connecting to the MC Unit

The procedure for connecting the Teaching Box to the MC Unit is described below.

- Note**
1. Be sure that the power supply is turned OFF before mounting or removing the ROM Cassette.
 2. For a connecting cable with a lock mechanism, be sure that the lock is securely fastened.

Connecting Cables

Use the connecting cables listed below (sold separately) to connect the Teaching Box to the MC Unit.

Model	Cable length
CV500-CN224	2 m
CV500-CN424	4 m
CV500-CN624	6 m

Attaching the Keysheet

Attach the Keysheet to the MC Unit as shown below.

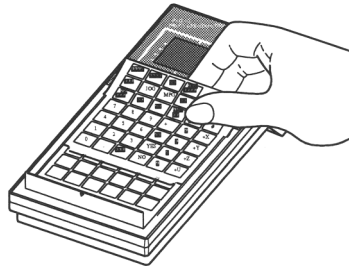

Installing the ROM Cassette

Install the ROM Cassette as shown below, and secure it with a M3 x 5-mm screw.

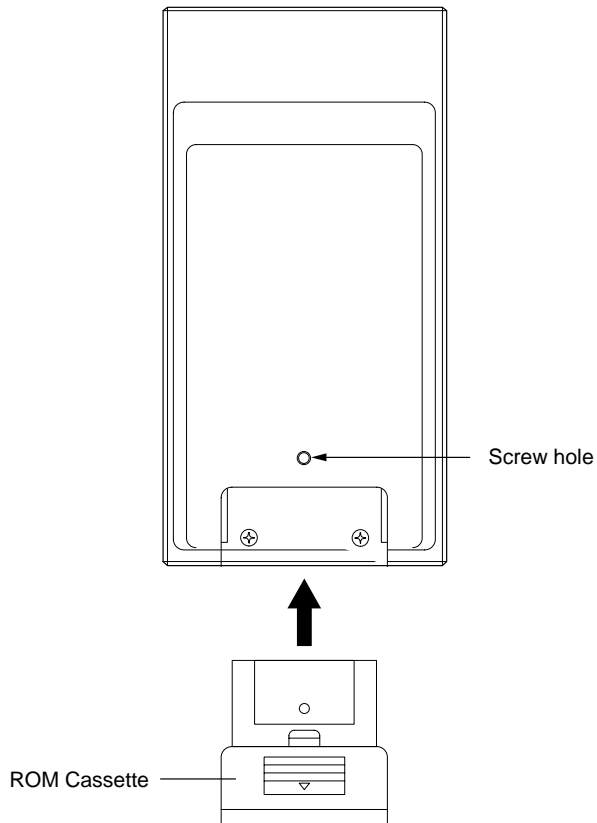

Connecting to the MC Unit

- 1, 2, 3... 1. Remove the connector cover.

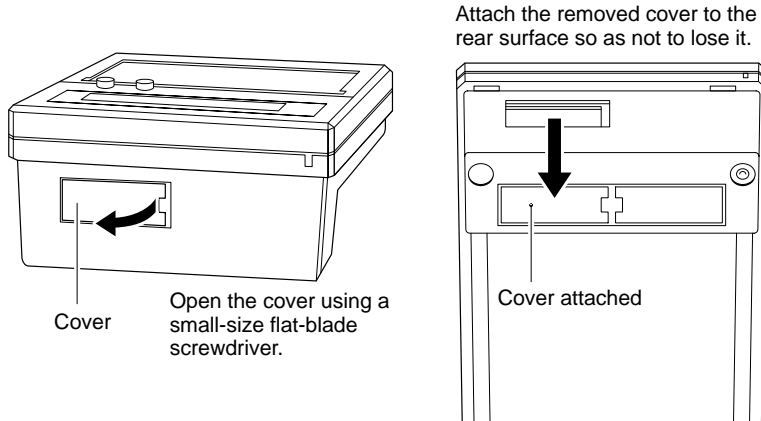

2. Plug the connecting cable's connector into the Teaching Box's connector.

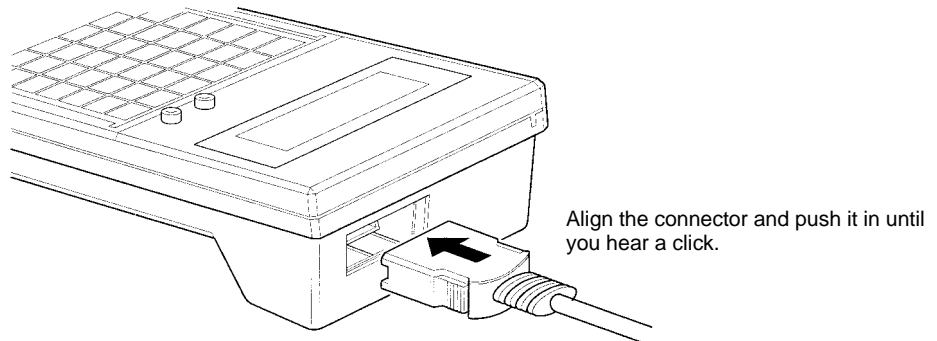

3. Insert the connecting cable's connector into the MC Unit's peripheral connector. For the CS1W-MC221/421 and CV500-MC221/421, "T.B" is written on the connector and for the C200H-MC221, "TOOL" is written on the connector. The location of the peripheral connector on each of the MC Units is shown below.

For the C200H-MC221, connect the connector and then set the tool selection switch to "T.B."

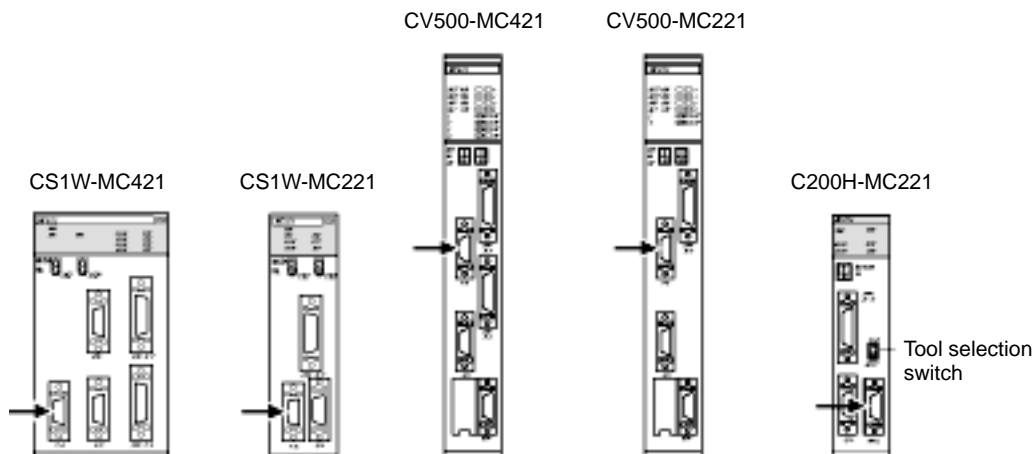

Removing the Cable

Using your fingers, press in and hold the clamps on both sides of the connector and pull out the connector.

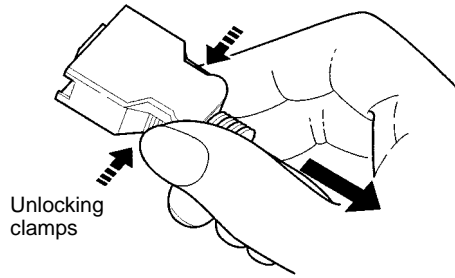

Adjusting the Buzzer and Display Contrast

Turn the volume control knob to adjust the loudness of the buzzer.

Turn the contrast control knob to adjust the contrast of the LCD display.

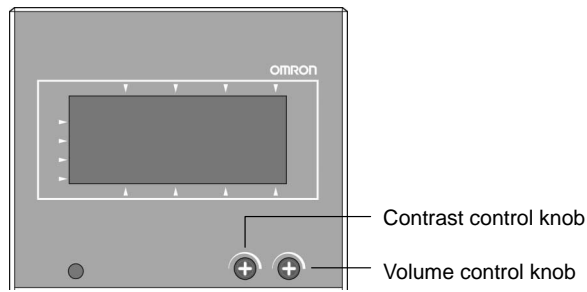

3-2 Installing in a Panel

The procedure for installing the Teaching Box in a panel is described below.

Use the C200H-ATT01 Mounting Bracket (sold separately) to instal the Teaching Box in a panel.

Note When using the Teaching Box inside a control panel, be sure to maintain the ambient temperature and relative humidity within the specified ranges.

- 1, 2, 3... 1. Prepare mounting holes according to the following diagram.

Mounting Hole Dimensions

The following is a standard panel cut.
(Conforming to DIN43700)

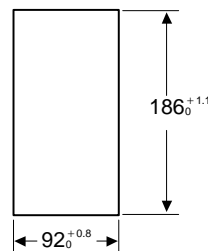

2. Provide sufficient spaces so that the connector can be easily connected or disconnected to/from the Teaching Box.

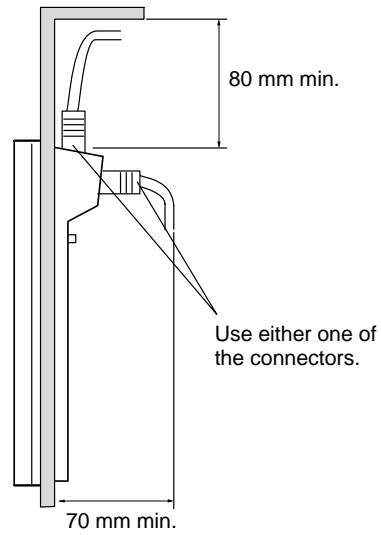

3. Mount the Teaching Box, aligning with the mounting holes and tighten the Mounting Bracket from the back side using screws.

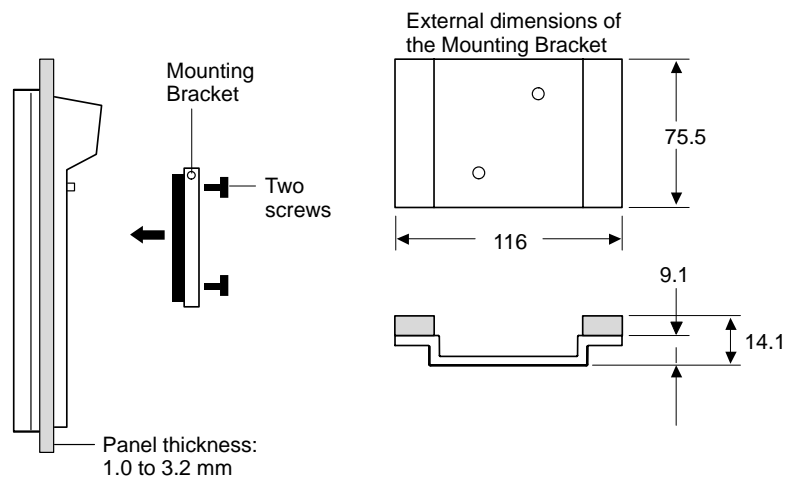

3-3 Selecting the Connected Model

Set the model that the Teaching Box is connected to. Select “MC Series” out of the following:

- Servodriver (Position Driver)
- MC Series (Motion Control)
- 3G2A5-NC111-EV1 Position Control Unit
- C500-NC222-E Position Control Unit

The MC Series is the default setting. When it is set to another Unit and changes are necessary, use the procedure outlined below to set it to the MC Series. Select the model that was connected as explained in 3-1 *Connecting to the MC Unit*.

- 1, 2, 3...** 1. Turn ON the power to the PC.
The following screen will be displayed.

When MC Series is selected

```
TBOX-V1.00
  MC SERIES
↑:SET CLR:CONN
```

When C500-NC222-E is selected

```
TBOX-V1.00
  NC222
↑:SET CLR:CONN
```

When 3G2A5-NC111-EV1 is selected

```
TBOX-V1.00
  NC111-V1/NC112
↑:SET CLR:CONN
```

When Servodriver is selected

```
TBOX-V1.00
  SERVODRIVER
  9600
↑:SET CLR:CONN
```

If “MC SERIES” is displayed here, it will not be necessary to change the setting and the following procedure will not be needed.

2. Press the Up Cursor Key.

```
MODEL SETTING
1:MC SERIES
2:NC222
3:NC111V1/NC112▼
```

3. Press the “1” Key. MC Series has been set.
4. To restore the initial screen, press the CLR Key.

3-4 Changing the Display Language (English/Japanese)

Use this procedure to change the display language for the Teaching Box between English and Japanese.

CS1W-MC221/421

Changing of the display language is performed in the EXTENSION mode. When power is supplied the screen will be displayed in English.

After "MC Series" has been set as the connected model, press the CLR Key. After the initial screen has been restored (refer to 3-3 *Selecting the Connected Model*), perform the settings in EXTENSION mode.

Caution Do not change the display language while the program is being executed or while a motor is moving. Unexpected operation can result.

For details regarding online connections, refer to 4-1 *Initial Operation*.

CV500-MC221/421, C200H-MC221

It is necessary to set the display language both before and after online connection. The Teaching Box display language before online connection is set from the Teaching Box. After online connection this setting is made using the MC Unit's DIP switch.

For details on online connection refer to 4-1 *Initial Operation*.

In the following example, the Teaching Box and MC Unit are connected, as described in 3-1 *Connecting to the MC Unit*.

Note Before performing this operation, be sure that the power to the PC is OFF.

CS1W-MC221/421

1. Turn ON the power to the PC.

```
TBOX-V1.00
MC SERIES
↑:SET CLR:CONN
```

2. Press the CLR Key. After approximately 2 s the initial screen will be displayed.

```
MDNIX*      0.00
ORGIY*      0.00
IZ*         0.00
IU*         0.00
```

3. Press the EXT Key.

```
EXTI 1/3
1. CHANGE MODE
2. SERVO LOCK
3. SERVO FREE
```

4. Press "6."

```
EXTI-LANGUAGE-
| JAPANESE
|
| SWITCH: ↑, ↓
```

5. Press the Up/Down Cursor Key to select English or Japanese as desired.

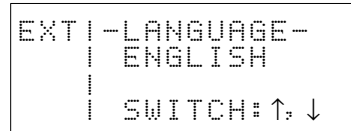

6. Press the WRITE Key. From now on, messages will be displayed in the language selected.

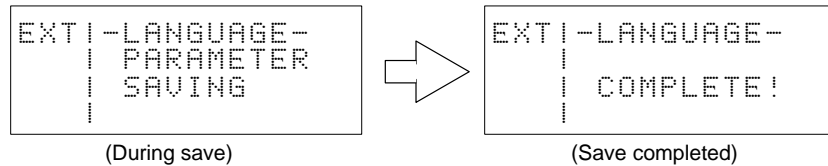

CV500-MC221/421

1, 2, 3... 1. Remove the DIP switch cover on the front of the MC Unit.

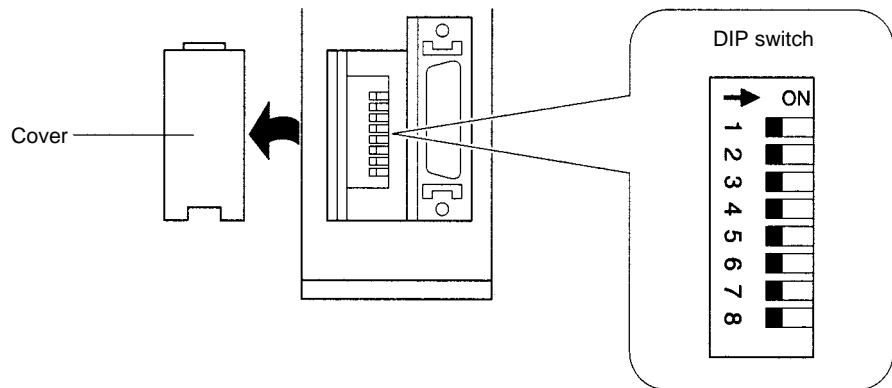

2. Set pin 2 of the DIP switch to ON for English and to OFF for Japanese. The default setting is OFF (Japanese). Set it to ON for English displays.
 3. Turn ON the power to the PC.

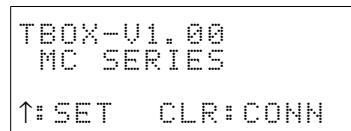

4. Press the Up Cursor Key.

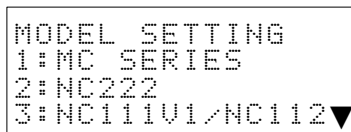

5. Press "1."

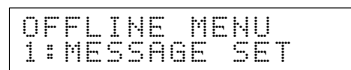

6. Press "1."

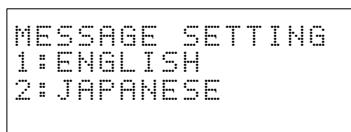

7. Press either "1" or "2."

Note Once the connections have been completed, setting of the connected device can be performed using the following operations when changing the display language between English and Japanese:

- Turning ON the power supply for the PC while pressing the CLR Key.
- Connecting the Teaching Box while pressing the CLR Key.

The setting of pin 2 will be checked and become valid only when the power to the PC is turned ON.

C200H-MC221

To display messages in Japanese on the Teaching Box, set pin 2 of the DIP switch on the MC Unit's rear panel to OFF.

The default setting is ON (English.)

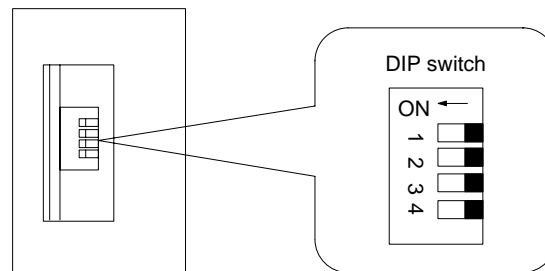

The remaining procedure is the same as that for the CV500-MC221/421.

Note Once the connections have been completed, setting of the connected device can be performed using the following operations when changing the display language between English and Japanese:

- Turning ON the power supply for the PC while pressing the CLR Key.
- Connecting the Teaching Box while pressing the CLR Key.

The setting of pin 2 will be checked and become valid only when the power to the PC is turned ON.

SECTION 4

Basic Operations

This section contains information on the basic operations necessary for operating the Teaching Box. Be sure to read this section to fully understand the basic operations before reading detailed descriptions of each function given in subsequent sections.

4-1	Initial Operation	32
4-2	Changing the MC Unit Control Mode	33
4-3	Changing the Teaching Box Mode	35
4-4	Direct Functions	35
4-5	Basic Input Operations	36
4-6	Axis and Task Displays	37
4-7	Handling Error Messages	37
4-8	Table of Operations	39

4-1 Initial Operation

This section describes the screen following power-up and explains online connection with the MC Unit.

- 1, 2, 3... 1. Turn ON the power to the PC. The following display will appear.

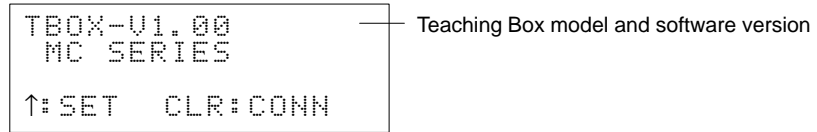

2. Press the CLR Key.

C200H-MC221

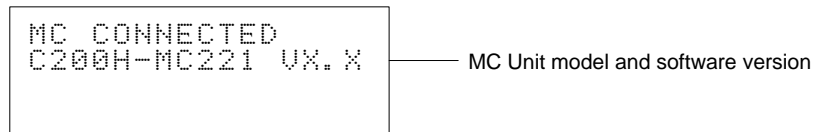

CV500-MC421

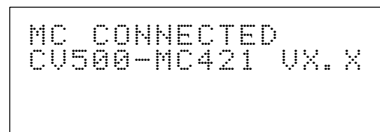

CV500-MC221

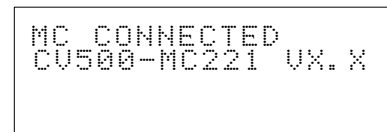

CS1W-MC421

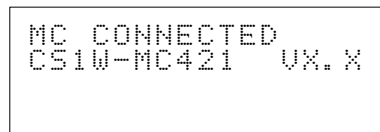

CS1W-MC221

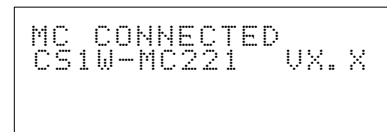

↓ After 2 seconds the following display will appear.

CV500-MC221/421, CS1W-MC221/421

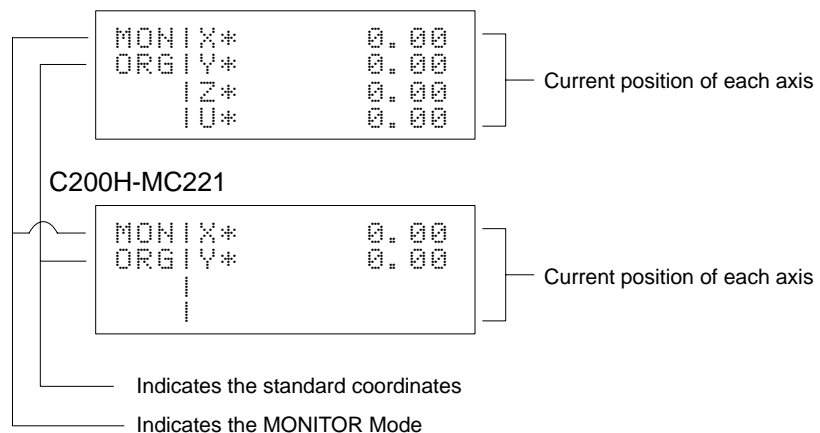

3. Perform the necessary key operations.

- Note**
1. When the power is turned ON, the MONITOR mode is always displayed.
 2. The MC Unit is initially set to the T.BOX LIMITED mode, which allows only monitoring from the Teaching Box.

To perform functions other than monitoring, change the MC Unit control mode.

4-2 Changing the MC Unit Control Mode

Control Modes

The MC Unit has three control modes; T.BOX LIMITED, T.BOX ENABLED, and T.BOX RESERVED.

Note For details on these three modes, refer to 2-2 MC Unit Control Modes.

The MC Unit is initially set to the T.BOX LIMITED mode, which allows only monitoring from the Teaching Box. The control mode can only be changed from the Teaching Box.

To perform other operations, the MC Unit control mode must be changed to either T.BOX ENABLED or T.BOX RESERVED.

When an attempt is made to select a function other than monitoring, the following error message will appear if the MC Unit is in T.BOX LIMITED mode.

```
CHANGE TO T.BOX
ENABLED OR T.BOX
RESERVED MODE
AND PROCEED.
```

A buzzer will sound when this error message appears.

When the above message appears, clear the message using the procedure outlined in procedure two.

Procedure

Changing the Mode to T.BOX ENABLED

The following procedure shows how to change to the T.BOX ENABLED mode.

- 1, 2, 3... 1. Press the EXT Key.
CS1W-MC421



```
EXTI 1/3
1. CHANGE MODE
2. SERVO LOCK
3. SERVO FREE
```

2. Press "1."



```
EXTI-CHG MODE-
| T.BOX
| LIMITED
| SWITCH: ↑, ↓
```

3. Press the Down Cursor Key.
(Press the Up Cursor Key or the Down Cursor Key to select either T.BOX LIMITED, T.BOX RESERVED, or T.BOX ENABLED.)



```
EXTI-CHG MODE-
| T.BOX
| RESERVED
| SWITCH: ↑, ↓
```

Procedure

Clearing Error Messages

The following procedure shows how to clear an error message. The procedure to clear the error message that is displayed with the CS1W-MC421 when an EXTENSION mode function for the absolute encoder is selected without setting the mode to T.BOX ENABLED is shown as an example.

```
EXTI 2/3
4. MEM PROTECT
5. ABS ORIG SET
6. LANGUAGE
```

EXTENSION mode menu

- 1, 2, 3... 1. In the T.BOX RESERVED state, press "5."
An error message is displayed.

5

```
CHANGE TO T.BOX  
ENABLED OR T.BOX  
RESERVED MODE  
AND PROCEED.
```

A buzzer will sound when this error message appears.

2. Press the CLR Key.
The error message will be cleared, and the previous screen will be returned.

CLR

```
EXTI 2/3  
4. MEM PROTECT  
5. ABS ORIG SET  
6. LANGUAGE
```

4-3 Changing the Teaching Box Mode

The Teaching Box is initially set to the MONITOR mode.

When operating the Teaching Box in another mode, change the mode using the mode keys.

When the control mode of the MC Unit is set to T.BOX LIMITED, only monitoring is possible.

Procedure

The following procedure can be used to change to the ORIGIN SEARCH mode.

- 1, 2, 3... 1. Set the control mode of the MC Unit to either T.BOX RESERVED or T.BOX ENABLED.
2. Press the ORIG SRCH Key.

Example: CV500-MC421 or CS1W-MC421

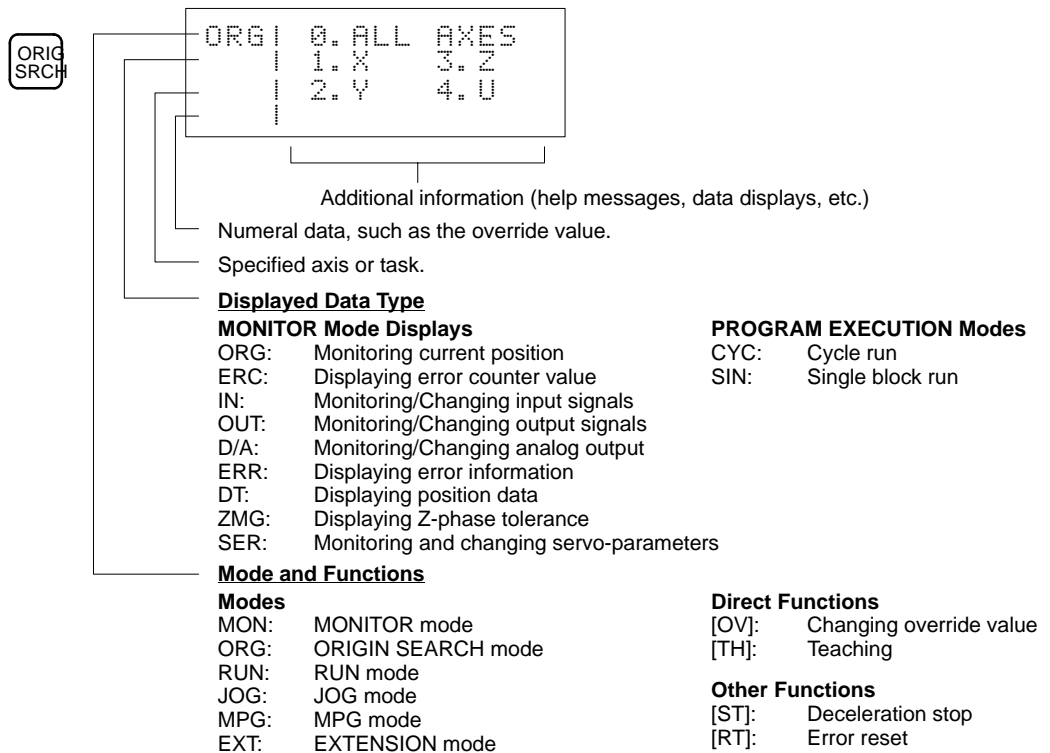

Refer to Sections 5 to 7 for details on operations in each mode.

4-4 Direct Functions

Some functions can be executed regardless of the Teaching Box mode, unless the control mode of the MC Unit is set to T.BOX LIMITED. These functions are called direct functions.

The MC Unit can be operated directly from the Teaching Box.

Pressing a direct function key will execute the corresponding function regardless of the Teaching Box mode.

The following two direct functions are available

- Changing the override value
- Teaching position data

Procedure

The following procedure can be used to change the override value.
Press the OVERRIDE Key.

Example: CV500-MC421 or CS1W-MC421

The direct function name is represented by the two letters in parentheses.

[OV]X	100.0	[OV]: Override
Y	50.0	[TH]: Teaching
Z	100.0	
U	50.0	

Refer to *Section 8 Direct Functions* for further details on direct functions.

4-5 Basic Input Operations

Basic input operations that are common in the Teaching Box operations are described below.

Basic Operation 1

Inputting Numeric Values

Use the 0 to 9, ., +/- Keys to input numeric values.
When a numeric value is input, the previous value is deleted.

Example: CV500-MC421 or CS1W-MC421

MONIX	10.0
D/AIV	10.0
I2	1.0
I0	-10.0

1

MONIX	10.1
D/AIV	10.0
I2	1.0
I0	-10.0

If the number just input is wrong, press the CLR Key to return to the previous value.

CLR

MONIX	10.0
D/AIV	10.0
I2	1.0
I0	-10.0

Basic Operation 2

Setting Input Values

There are two methods to set input values.

- One method is to press a specific key other than a numeric key or CLR Key after inputting a numeric value.

This method is used when inputting data, such as a program number, that does not need to be stored in the system.

Do not press the WRITE Key when not storing data in the system. When changing the D/A output, press the WRITE Key.

- The other method is to press the WRITE Key after inputting a numeric value.

This method is used when inputting data, such as position data, that must be stored in the system.

If there is more than one input item, pressing the WRITE Key will move the cursor to the next item.

Basic Operation 3

Returning to the Previous Display

- Press the CLR Key to return to the previous display. If the CLR Key is pressed while inputting numeric values, it will return the display to the previous numeric value.
- Press the CLR Key several times to return to the initial display for the current modes.

Basic Operation 4

Buzzer Operation

Each buzzer sound has the following meaning.

Sound	Meaning
Beep (short)	A valid key was pressed.
Beep-beep-beep (short)	An operation was attempted for an axis that is not controlled by the MC Unit. An invalid key was pressed. An error occurred.
Beep (longer)	An attempt was made to execute an invalid function for the current display or an error has occurred.

Basic Operation 5

Cursor Displays

The cursor appears as a “-” mark at the first input item only in displays that require input of numeric values.

4-6 Axis and Task Displays

Axes and tasks are displayed as shown below.

Axis Displays

The CV500-MC421 and CS1W-MC421 MC Units are capable of controlling a maximum of four axes. Accordingly, the axis data includes information on all four axes.

Example: Monitor Display

MONIX	-100.00
ORGIY	-10.1
I Z	10.0
I U	990.99

If you try to operate an axis that is not defined in any task, a warning buzzer will sound.

Task Displays

Axis data is displayed for each task, as shown in the following display.

Example: CV500-MC421 and CS1W-MC421 Teaching Display

[TH]X	100.00
Y	1000.0
TK1 Z	10.0
0000U	

Task No.

← No data is displayed for the U axis because it has not been assigned to task 1.

4-7 Handling Error Messages

Descriptions of error message displays and operations for clearing errors are shown below.

The Teaching Box continuously monitors the status of the system, tasks, and axes, and displays any errors that are detected. If more than one error occurs at the same time, an error message is displayed based on the following conditions.

- Only the first system error detected is displayed and stored in memory.

- Only the first task error detected for each task is displayed and stored in memory.
- Only the first axis error detected for each axis is displayed and stored in memory.

Error Display Example

The buzzer sounds when an error message is displayed.

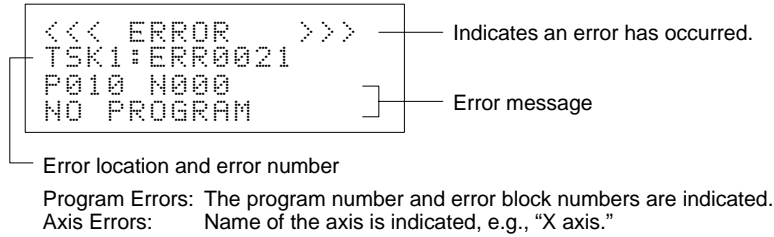

Procedure

Clearing and Resetting Errors

Example: CS1W-MC421

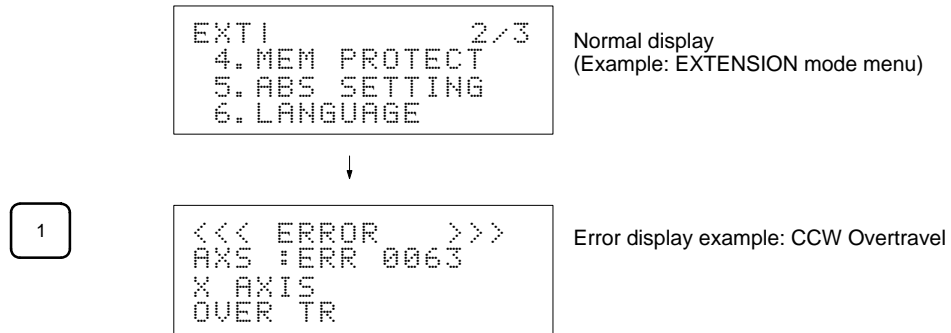

For further information on error messages refer to *Appendix B Error Displays and Error Processing* in this manual and to the troubleshooting section in the relevant MC Unit operation manual.

1, 2, 3...

1. Press the CLR Key.

The displayed error is cleared and the display returns to the one that existed just before the error occurred.

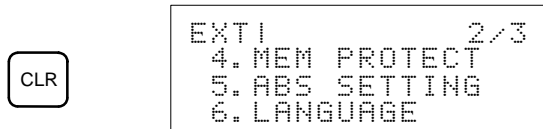

2. Set the MC Unit control mode to either T.BOX ENABLED or T.BOX RESERVED.
3. Press the ERR CLR Key.
After resetting the error display, remove the cause of the error.
Unless the cause of the error is removed, the same error will occur when the same function is executed.

For details on how to change the MC Unit control mode, refer to *4-2 Changing the MC Unit Control Mode*.

For information on resetting errors, refer to *9-2 Error Resetting*.

4-8 Table of Operations

The following table provides a summary of Teaching Box operations. Operations which appear in parentheses indicate operations which may be necessary, depending on the function and Teaching Box model used.

Function	Description	Operation procedure	Page
Monitoring	Monitors the current position. Monitors or changes I/O signals. Reads error information. Monitors or changes position data. (Changes are only possible with the CS1W-MC421/221 or the C200H-MC221.) Monitors Z-phase tolerance. Monitors or changes servo-parameters. (CS1W-MC421/221, C200H-MC221 only)		42 to 48
Origin search	Finds the origin of all or specified axes.		54
Program execution	Executes cyclic or single block run.		55
Jogging	Jogs axes.		57
MPG feeding	Feeds axes by MPG (manual pulse generator.)		58

Function	Description	Operation procedure	Page
Extension	<p>Changes the MC Unit control mode.</p> <p>Locks or unlocks the servomotor.</p> <p>Protects or clears memory protection for MC Unit memory.</p> <p>Performs initial settings for the absolute encoder. (CV500-MC421/221, C200H-MC221 only)</p> <p>Performs software reset for the absolute encoder. (CV500-MC421/221, C200H-MC221 only)</p> <p>Performs origin setting for the absolute encoder. (CS1W-MC421/221 only)</p> <p>Writes all types of data to the MC Unit flash memory. (CS1W-MC421/221, C200H-MC221 only)</p>	<pre> graph TD EXT[EXT] --> A[↓ / ↑] A --> B[1 / 6] B --> C["(7)"] C --> D[CLR] D --> E[YES] E --> F["0 to 2"] F --> G["(3 , 4)"] G --> H["↓ / ↑"] H --> EXT </pre>	62 to 70
Override	Changes the override value	<pre> graph TD OR[OVER RIDE] --> CHG[CHG] CHG --> A[↓ / ↑] A --> B[WRITE] B --> C["0 to 9 , ."] C --> OR </pre>	74
Teaching	Registers the position data.	<pre> graph TD TEACH[TEACH] --> TC["(TASK CHG)"] TC --> A["0 to 9"] A --> B[WRITE] B --> C[YES] C --> TEACH </pre>	75
Deceleration stop	Decelerates all axes to a stop.	<pre> graph TD DSTOP[DEC STOP] </pre>	78
Resetting	Resets errors that have occurred in the MC Unit or the Servodriver.	<pre> graph TD ECLR[ERR CLR] --> A["1 / 2"] A --> B["(0 to 4)"] B --> C[YES] </pre>	78

SECTION 5

MONITOR Mode Operations

This section describes the methods for monitoring the various kinds of data. The procedure described in the first subsection is required for monitoring any type of data. Read the first subsection before reading any other subsection.

5-1	MONITOR Mode	42
5-2	Monitoring the Present Position	43
5-3	Monitoring and Changing I/O Signals	44
5-4	Error Data Displays	46
5-5	Monitoring and Changing Position Data	47
5-6	Monitoring the Z-Phase Tolerance	48
5-7	Monitoring and Changing Servo Parameters	49

5-1 MONITOR Mode

The kinds of data shown in the following table can be monitored and changed in the MONITOR mode.

CV500-MC221/421

Menu item	Function	Page
1. PRESENT POSITION	Monitors the present position.	43
2. IN/OUT	Monitors or changes I/O signals.	44
3. ERROR	Reads error information.	46
4. POSITION DATA	Monitors position data.	47
5. Z-PHASE TOLERANCE	Monitors the Z-phase tolerance.	48

CS1W-MC221/421, C200H-MC221

Menu item	Function	Page
1. PRESENT POSITION	Monitors the present position.	43
2. IN/OUT	Monitors or changes I/O signals.	44
3. ERROR	Reads error information.	46
4. POSITION DATA	Monitors position data.	47
5. Z-PHASE TOLERANCE	Monitors the Z-phase tolerance.	48
6. SERVO PARAMETERS	Monitors and changes servo system parameters.	49

Procedure

Use the following procedure to access the MONITOR mode menu and select a function.

- 1, 2, 3... 1. Press the MON Key. The present position will be displayed.

CS1W-MC221/421

C200H-MC221



```

MONIX      0.00
ORGLV -399999.99
  LZ      0.0000
  IU    399999.99
    
```

```

MONIX      0.00
ORGLV -399999.99
  |
  |
    
```

CV500-MC221/421

```

MONIX      0.00
ORGLV -399999.99
  LZ      0.0000
  IU    399999.99
    
```

2. Press the CLR Key. The MONITOR mode menu will be displayed.

CS1W-MC221/421

C200H-MC221



```

MONI 1/2
1. PRESENT POSIT
2. IN/OUT
3. ERROR
    
```

```

MONI 1/2
1. PRESENT POSIT
2. IN/OUT
3. ERROR
    
```

CV500-MC221/421

```

MONI 1/2
1. PRESENT POSIT
2. IN/OUT
3. ERROR
    
```

3. Press the Down Key to see the remaining portion of the menu.

CS1W-MC221/421

C200H-MC221



```
MONI                2/2
4. POSITION DATA
5. Z-PHASE TOLER
6. SERVO PARAM
```

```
MONI                2/2
4. POSITION DATA
5. Z-PHASE TOLER
6. SERVO PARAM
```

CV500-MC221/421

```
MONI                2/2
4. POSITION DATA
5. Z-PHASE TOLER
```

These two displays can be switched with the Up and Down Keys.

4. Press one of the numeric keys 1 to 6 to select the desired operation.

5-2 Monitoring the Present Position

This operation displays the present position so that it can be monitored. It can be used for monitoring either the X and Y axes or the X, Y, Z, and U axis.

Data for axes that are not being used is also displayed.

If no encoder is connected to an axis that is not being used, the display will read "0." If an encoder is connected, the display increases or decreases depending on the rotation of the encoder.

Note This function can also be executed by selecting "1. PRESENT POSITION" in the MONITOR mode menu.

Procedure

Use the following procedure to monitor the present position.

Press the MON Key.

The present position in the reference coordinate system is displayed.

CS1W-MC221/421, CV500-MC221/421

C200H-MC221



```
MONIX                0.00
ORGIV -399999.99
IZ*                  0.000
IU                   0.000
```

```
MONIX                0.00
ORGIV -399999.99
|
```

An asterisk (*) indicates that the origin has not been defined.

Press the Up or Down Key to change the display method as shown below.

• Present Position for Standard Coordinate System (Pulses)

CS1W-MC221/421, CV500-MC221/421

C200H-MC221



```
MONIX                0P
ORGIV -39999999P
IZ*                  0P
IU                   0P
```

```
MONIX                0P
ORGIV -39999999P
|
```

**P" indicates that the unit is pulse.

With the CS1W-MC221/421, the value displayed is 1, 2 or 4 times the actual value according to the setting of the encoder multiplication rate in the mechanical specification parameters.

With the CV500-MC221/421 or C200H-MC221, the value displayed is 4 times the actual value.

For example, at an encoder resolution of 1,000 p/r, with an encoder multiplication rate of 4, one revolution from the 0-pulse position would be as follows:

$$1,000 \times 4 = 4,000.$$

• Deviation Counter Value (Pulses)

CS1W-MC221/421, CV500-MC221/421 C200H-MC221



```

MONIX      -200P
ERCIV      100P
  IZ*      -10P
  IO       0P
    
```

```

MONIX      -200P
ERCIV      100P
  I
    
```

With the CS1W-MC221/421, the value displayed is 1, 2 or 4 times the actual value according to the setting of the encoder multiplication rate in the mechanical specification parameters.

With the CV500-MC221/421 or C200H-MC221, the value displayed is 4 times the actual value.

5-3 Monitoring and Changing I/O Signals

This operation is used to display the status of input signals, output signals, and analog outputs.

The values of output signals and analog output can be changed.

Caution Before changing output signals or analog outputs, be sure that the equipment will not be affected.

Note Be sure that the operation according to the set values is correct.

The status of the following input and output signals are displayed.

Type	Signal
Input signals	Origin, CCW limit, CW limit, driver alarm input, immediate stop, and general-purpose inputs
Output signals	Run command, alarm reset, sensor ON, and general-purpose outputs
Analog output	Displays analog output in the range between -10.0 V and +10.0 V.

The values for output signals and analog outputs can be changed at their respective display screens.

Use the Up and Down Keys to switch among the input signal display, output signal display, and analog output display.

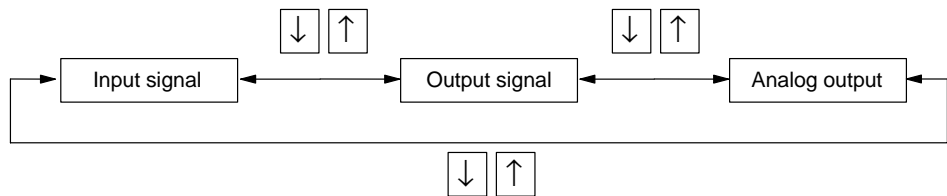

Procedure 1

Use the following procedure to monitor input signals.

- 1, 2, 3... 1. Select "2. IN/OUT" from the MONITOR mode menu,

CS1W-MC221/421, CV500-MC221/421 C200H-MC221



```

MONI      XYZU
IN IORIG POS0100
  ICCW LIMIT0001
  ICW  LIMIT0000
    
```

```

MONI      XY
IN IORIG POS 01
  ICCW LIMIT 00
  ICW  LIMIT 00
    
```

1: ON 0: OFF

2. Change the display using the Up and Down Keys.

CS1W-MC221/421, CV500-MC221/421

C200H-MC221



```
MONI      XYZU
IN |DRV ALRM0010
|STOP    0010
|
```

```
MONI      XY
IN |DRV ALRM 00
|STOP    00
|
```

DRV alarm: Driver alarm input

CS1W-MC221/421, CV500-MC221/421

C200H-MC221



```
MONI      1234
IN |GET IN  0010
|
|2
```

```
MONI      12
IN |GET IN  00
|
|B
```

GET IN: General-purpose inputs

Procedure 2

Use the following procedure to monitor the output signals.

1, 2, 3...

1. With the last screen of Procedure 1 displayed, press the Down Key.

CS1W-MC221/421, CV500-MC221/421

C200H-MC221



```
MONI      XYZU
OUT|RUN COM 0010
|ALM RSET0000
|SENSR ON1111
```

```
MONI      XY
OUT|RUN COM 00
|ALM RSET 00
|SENSR ON  11
```

2. Change the display using the Up and Down Keys.

CS1W-MC221/421, CV500-MC221/421



```
MONI      1234
OUT|GET OUT 0010
|
```

There are no general-purpose outputs for the C200H-MC221.

GET OUT: General-purpose outputs

Procedure 3

Use the following procedure to monitor the analog outputs.

With the last screen of the Procedure 2 displayed, press the Down Key.

CS1W-MC221/421, CV500-MC221/421

C200H-MC221



```
MONIX      10.0
D/AIY*    10.0
|Z        1.0
|O        -10.0
```

```
MONIX      10.0
D/AIY*    10.0
|
|
```

Analog output status is displayed in the range between -10.0 V and +10.0 V.

Procedure 4

Use the following procedure to change the output signals.

1, 2, 3...

1. After selecting the output signal from the MONITOR mode display, press the CHG Key.

CS1W-MC221/421, CV500-MC221/421

C200H-MC221



```
MONI      XYZU
OUT|RUN COM 0010
|ALM RSET0000
|SENSR ON1111
```

```
MONI      XY
OUT|RUN COM 00
|ALM RSET 00
|SENSR ON  11
```

- Press the CLR Key to return to the initial display.
- Follow the steps given below to change the value.
Use the Up and Down Keys to move the cursor.
The data is input in combinations of 0 and 1, from 0 to 1111 for the CS1W-MC221/421 and CV500-MC221/421. Input for the U or Z axes is invalid for the CS1W-MC221 and the CV500-MC221.
The data is input in combinations of 0 and 1, from 0 to 11 for the C200H-MC221.
For example, for the CS1W-MC421, input "0001" to output an operation instruction to the U axis and leave the other axes unchanged.
Pressing the CLR Key while data is being input will reset the display to the output state right before the data was input.
 - Press the WRITE Key to set and output the newly input data.



Procedure 5

1, 2, 3...

- Use the following procedure to change an analog output.
- After selecting the analog output from the MONITOR mode display, press the CHG Key.

CS1W-MC221/421, CV500-MC221/421 C200H-MC221

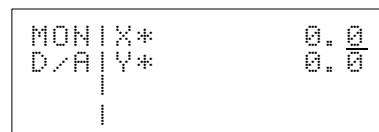
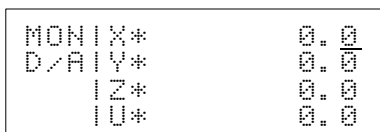

- Change the value.
Data can be input in the range between -10.0 and +10.0.
Other input procedures are the same as in Procedure 4, above.



- Press the WRITE Key.
The newly input data is defined and output.

Note When changing the values displayed in Procedures 4 and 5 above, the following two conditions must both be satisfied:

- The MC Unit's operating mode must be set to either "T.BOX ENABLED" or "T.BOX RESERVED."
- All axes must be in servo-unlock status.

If either of these conditions is not satisfied, one of the following messages will be displayed.

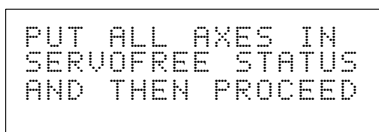
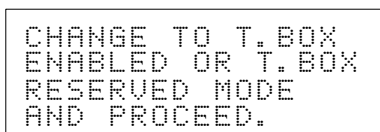

Press the CLR Key to return to the previous screen.
For details on changing the operating mode, refer to 4-2 *Changing the MC Unit Control Mode*. For details regarding servo-lock and servo-unlock, refer to 7-2 *Servo Lock*.

5-4 Error Data Displays

Information on errors that have occurred in the system or in tasks 1 to 4 can be read and displayed using this operation.

If an error occurs during normal operation, the display will automatically change to the error display.

For details on automatic error displays and error resetting, refer to 9-2 *Error Resetting*.

Procedure

Use the following procedure to access error data.

- 1, 2, 3... 1. Select "3. ERROR" from the MONITOR mode menu.

CS1W-MC221/421, CV500-MC221/421 C200H-MC221

3

```
MONISYSTEM  -
ERRI        1234
ITASK       -E--
IAXIS       --E-
```

```
MONISYSTEM  -
ERRI        12
ITASK       -E
IAXIS       --
```

"E" is displayed where errors have occurred.

"-" indicates a normal state (no error).

"1" to "4" correspond to the X through U axes.

2. Press the Down Key.

For the CS1W-MC221/421 and CV500-MC221/421, errors are displayed in the following order: system, task 1, task 2, task 3, task 4, X axis, Y axis, Z axis, and U axis. Only items where errors have occurred are displayed.

Example: Error in Program Execution

↓

```
<<< ERROR >>>
TSK2:ERR0021
P010 N000
NO PROGRAM
```

Example: Error in Jogging

↓

```
<<< ERROR >>>
AXS :ERR 0063
AXIS X
CCW OVER TR
```

Note If an error has occurred in more than one item, change the display using the Up and Down Keys.

5-5 Monitoring and Changing Position Data

 **Caution** Confirm that no adverse effect will occur in the system before changing any set value in memory.

 **Caution** Confirm that the set parameters operate correctly.

This operation is used to display position data stored in the MC Unit so that it can be monitored. When the CS1W-MC421/221 or C200H-MC221 is used, position data can also be changed.

The position data is stored in A0000 to A1999.

Procedure 1

Use the following procedure to display position data.

- 1, 2, 3... 1. Select "4. POSITION DATA" from the MONITOR mode menu.

4

```
MONIPOSIT  A0000
DT |
  |
  |
```

- Input the address number of the first position to be monitored.
"100" is input in this example.



```
MONIPOSIT  A 100
DT |
  |
  |
```

If this step is skipped, the display will start from A0000.

- Press the Down Key.
Four positions starting from the one designated in step 2 will be displayed.



```
A0100=-3999.9999
A0101=  0.0000
A0102=  -1.0000
A0103= 3999.9999
```

Press the Down Key to display the next positions and the Up Key to display the previous positions.



```
A0101=  0.0000
A0102=  -1.0000
A0103= 3999.9999
A0104= 50.0000
```

Procedure 2

Use the following procedure to monitor position data. (This procedure can only be used with a CS1W-MC421/221 or C200H-MC221 Motion Control Unit.)

- 1, 2, 3... 1. While the screen showing the position data is displayed, press the CHG Key.

```
A0100=-3999.9999
A0101=  0.0000
A0102=  -1.0000
A0103= 3999.9999
```

← The cursor is displayed here.

(To return to the screen prior to when the CHG Key was pressed, press the CLR Key.)

2. Change the values.
Use the Up and Down Keys to move the cursor, and then enter the position data with the +/- Key and the numeric keys from 0 to 9. Data can be input within a range of -39,999,999 to 0.0000 to +39,999,999.
Pressing the CLR Key while data is being input will restore the prior data.
3. Press the WRITE Key to set the data.

Note When the WRITE Key is pressed, the position data is stored in RAM and will be lost if the power is turned OFF. To save the changes, use the DATA SAVE operation to store the position data in flash memory.

5-6 Monitoring the Z-Phase Tolerance

This operation is used to display the Z-phase tolerance.
When the origin search operation has been completed for all the axes, the distance between the proximity sensor and the Z phase signal of the encoder is displayed as an absolute value (in pulse units).
With the CS1W-MC221/421, the value displayed is 1, 2 or 4 times the actual value according to the setting of the encoder multiplication rate in the mechanical specification parameters.

With the CV500-MC221/421 or C200H-MC221, the value displayed is 4 times the actual value.

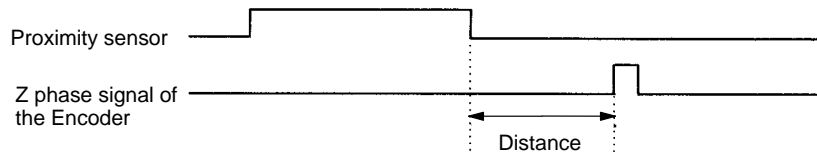

Note This function is normally used during adjustments of the system after the origin search operations are completed.

Procedure

Use the following procedure to display the Z-phase tolerance so that it can be monitored.

Select "5. Z-PHASE TOLERANCE" from the MONITOR mode menu.

CS1W-MC221/421, CV500-MC221/421 C200H-MC221

5

MONIX	1000P
ZMGIY*	0P
I2	11P
I0	2000P

MONIX	1000P
ZMGIY*	0P
I	

An asterisk (*) indicates that the origin has not been defined.

In this example, the tolerance for the Y axis is not displayed because the origin search operation for the Y axis has not been completed.

The Z-phase tolerance may vary somewhat according to the speed at the time the Z-phase is detected. This variation can be determined by means of the following equation:

$$\text{Variation [pulses]} = (\text{Speed when Z-phase detected [p/s]} / 250)$$

With the CV500-MC221/421 and C200H-MC221, the tolerance is always 0 for axes using an absolute encoder.

5-7 Monitoring and Changing Servo Parameters

Caution Confirm that no adverse effect will occur in the system before changing any set value in memory.

Caution Confirm that the set parameters operate correctly.

The procedure shown below can be used to monitor and change servo parameters.

Note Servo parameters can only be changed for the CS1W-MC221/421 and C200H-MC221.

Procedure 1

Use the following procedure to display servo parameters.

- 1, 2, 3... 1. Select "6. SERVO PARAMETERS" from the MONITOR mode menu.
Just after the power is turned ON, the X-axis residual pulse warning value is displayed.

CV500-MC221/421, C200H-MC221 CS1W-MC221/421

MONI	1/5
SERERR CNT WARN	
X (0-65000)	
I	10000

MONI	1/7
SERERR CNT WARN	
X (0-65000)	
I	10000

2. Use the Up and Down Keys to switch between the following data displays.

CV500-MC221/421, C200H-MC221

CS1W-MC221/421



```
MONI                2/5
SER|IN POSITION
X | (0-999)
|
| 10
```

```
MONI                2/7
SER|IN POSITION
X | (0-10000)
|
| 10
```

```
MONI                3/5
SER|POS GAIN
X | (5-250)
|
| 40
```

```
MONI                3/7
SER|POS GAIN
X | (1-250)
|
| 40
```

```
MONI                4/5
SER|POS FF GAIN
X | (0-100)
|
| 0
```

```
MONI                4/7
SER|POS FF GAIN
X | (0-100)
|
| 0
```

```
MONI                5/5
SER|BACKLASH
X | (0-999)
|
| 0
```

```
MONI                5/7
SER|BACKLASH
X | (0-10000)
|
| 0
```

```
MONI                6/7
SER|BRAKE OFF
X | (0-10000)
|
| 0
```

```
MONI                7/7
SER|BRAKE ON
X | (0-10000)
|
| 0
```

The X-axis and Y-axis parameters can be changed as follows:

X-axis parameter selection: -X or +X

Y-axis parameter selection: -Y or +Y

After the change, the same parameters will be displayed.

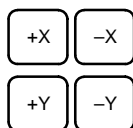

```
MONI                5/5
SER|BACKLASH
X | (0-999)
|
| 10
```



```
MONI                5/5
SER|BACKLASH
Y | (0-999)
|
| 0
```

Procedure 2

Use the following procedure to change servo parameters.

Note Servo parameters can only be changed for the CS1W-MC221/421 and C200H-MC221.

- 1, 2, 3...** 1. With the servo parameters displayed, press the CHG Key. The cursor will be displayed.

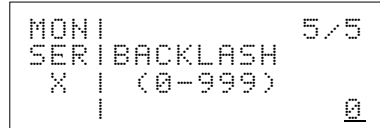

```
MONI 5/5
SERIBACKLASH
X | (0-999)
|
```

The previous output status will be retained.

2. Change the values. The input methods are the same as for changing I/O signals.

Press the WRITE Key to set the data.

Note When the WRITE Key is pressed, the changed values are stored in RAM and will be lost if the power is turned OFF. To save the changes, use the DATA SAVE operation to store the data in FLASH memory.

SECTION 6

Origin Searches, Program Execution, Jogging, and MPG

This section provides information on procedures for origin searches, program execution, jogging, and handle feeding operations. Execute these operations only after locking the servo for the axis to be moved.

6-1	Origin Search	54
6-2	Program Execution	55
6-3	Jogging	57
6-4	Handle Feeding	58

6-1 Origin Search

This operation is used to execute origin searches for a specified axis or for all axes.

 **Caution** Before executing an origin search, be sure that it will not affect the equipment.

• CV500-MC221/421, C200H-MC221

The present position will be force-set to 0 to define the present position as the origin if the origin search operation is entered with the origin search method set to set the origin when power is turned ON.

If the origin search method is set to any other method, the origin search is executed using the following two steps.

Step 1: The mechanical origin is located.

Step 2: A move is made to the origin in the reference coordinate system.

When origin search is performed for an axis using an absolute encoder, it will move to the mechanical origin (reference coordinate system origin).

Press the PAUSE Key to cancel an origin search during execution.

- Note**
1. The offset value between the mechanical origin and the origin in the reference coordinate system must be set in advance using the system parameter.
 2. The offset value is not valid for axes using an absolute encoder.
 3. The ORIGIN SEARCH mode is specified as a system parameter.

• CS1W-MC221/421

The present position will be force-set to 0 to define the present position as the origin if the origin search operation is entered with the origin search method set to set the origin when power is turned ON.

If the origin search method is set to any other method, the origin search is executed using the following two steps.

Step 1: The mechanical origin is located.

Step 2: A move is made to the origin in the reference coordinate system.

Origin search can be performed for an axis using an absolute encoder in the same way as for an incremental encoder.

Press the PAUSE Key to cancel an origin search during execution.

- Note**
1. The offset value between the mechanical origin and the origin in the reference coordinate system must be set in advance using the system parameter.
 2. The ORIGIN SEARCH mode is specified as a system parameter.

Procedure

Use the following procedure to execute an origin search for all axes.

- 1, 2, 3...** 1. Press the ORIG SRCH Key.

CS1W-MC221/421, CV500-MC221/421 C200H-MC221

ORIG
SRCH

```

ORIG| 0. ALL AXES
      | 1. X      3. Z
      | 2. Y      4. U
      |
  
```

```

ORIG| 0. ALL AXES
      | 1. X
      | 2. Y
      |
  
```

2. Press "0."

When selecting an individual axis, press one of the numeric keys 1 to 4.

0

```

ORG |
    | OK?
ALL |
    | YES / NO
    
```

Indicates that all axes have been selected. Selected axes are indicated as follows:

ALL: All axes, X: X axis, Y: Y axis, Z: Z axis and U: U axis
 For the CS1W-MC221, C200H-MC221: ALL: All axes, X: X axis, Y: Y axis

3. Press the YES Key.

The origin search is started and the present position monitor display appears.

CS1W-MC221/421, CV500-MC221/421 C200H-MC221

YES

```

ORGIX*      0.00
|Y* -399999.99
ALLIZ*      0.000
|U*         0.00
    
```

```

ORGIX*      0.00
|Y* -399999.99
ALL|
|
    
```

An asterisk (*) indicates that the origin has not been defined.

The present position is updated for the axes in motion.

When an axis has come to a stop at the origin in the reference coordinate system, the origin search is completed and the asterisks in the display disappear.

The following display will appear when the search has been completed for all designated axes.

```

ORG |
    |
ALL | COMPLETE!
    |
    
```

4. Press the CLR Key.

The axis selection display shown in step 1, above, will return.

- Note**
1. The CLR Key is not valid during origin searches.
 2. Press the PAUSE Key to cancel the origin search.

6-2 Program Execution

This operation is used to execute the program using a cycle run or a single-block run.

A program and task stored in the MC Unit are designated for execution.

Cycle Run

The designated program is executed from the beginning.

Single-block Run

The designated program is executed block by block.

- Note** Programs can be easily debugged by alternately executing them using a cycle run and single-block run.

Procedure 1

Use the following procedure to execute a cycle run.

- 1, 2, 3...** 1. Press the PROG EXEC Key.



```
RUN| 1. CYCLE RUN
    | 2. SINGLE RUN
    |
    |
```

2. Select "1. CYCLE RUN" from the RUN mode menu.



```
RUN| -CYCLE RUN-
    | CYC|PROGRAM P000
    | TK1|BLOCK N000
    |   | RUN: START
```

Indicates task 1.

Press the TASK CHG Key to change the task.

3. Designate the program number.
In this example, "50" has been input.

```
RUN| -CYCLE RUN-
    | CYC|PROGRAM P 50
    | TK1|BLOCK N000
    |   | RUN: START
```

If the program has been altered from the MC Support Software, input the program number again, even when executing the same program. If the program number is not input again, an error will occur. The new program will be executed from the first block.

4. Press the PROG EXEC Key.

```
RUN| STATUS RUN
    | CYC|PROGRAM P050
    | TK1|BLOCK N010
    |
```

Status
 RUN: Under operation
 END: Operation completed
 ERR: Error occurred.
 PAUSE: Temporarily stopped

If the PAUSE Key is pressed, the program will be temporarily stopped and the display will revert to the previous one.

Program execution will resume when the PROG EXEC is pressed. If the program number is input, the program will start from the beginning.

The program cannot be executed if any error has occurred.

5. Press the CLR Key to return to the RUN mode menu.
The CLR Key is not valid during program execution.
To return to the restart display, press the CLR Key while the status is END or ERR.

Procedure 2

Use the following procedure to execute a program block by block.

- 1, 2, 3...** 1. Press the PROG EXEC Key.



```
RUN| 1. CYCLE RUN
    | 2. SINGLE RUN
    |
    |
```

2. Select "2. SINGLE RUN" from the RUN mode menu.

2

```

RUN1-SINGLE RUN-
SINI PROGRAM P000
TK1|BLOCK N000
| RUN: START
    
```

Indicates task 1.
Press the TASK CHG Key to change the task.

3. Designate a program number.

In this example, "50" is input.

5 0

4. Press the START Key.

The first block of the program number 50 will be executed.

START

```

RUN1 STATUS RUN
SINI PROGRAM P050
TK1|BLOCK N001
|
    
```

Press the PAUSE Key to stop execution in progress.

When first block has been executed, the status will be set to PAUSE and execution will stop.

The next block number to be executed will be displayed.

```

RUN1 STATUS PAUSE
SINI PROGRAM P050
TK1|BLOCK N002
| RUN: START
    
```

Press the START Key while the status is set to PAUSE to execute the next block.

CLR

5. Press the CLR Key to return to the display to input the program number.

Press the CLR Key again to return to the RUN mode menu display.

- Note**
1. Press the PAUSE Key during cycle run execution to stop the program. Then, press the CLR Key to access the RUN mode menu. Select the single-block run operation on the menu to resume operation using a single-block run.
 2. Programs can be more easily debugged by alternately executing cycle runs and the single-block runs.

6-3 Jogging

This operation is used to jog an axis.

Caution Before executing a jogging operation, be sure that it will not affect the equipment.

The actual feedrate used for jogging is determined according to the following formula.

$$\text{Feedrate} = \text{Override (\%)} \times \text{Maximum jog feedrate}$$

The maximum jog feedrate is set as a parameter in advance.

To teach positions during jogging, press the TEACH Key where necessary.

Refer to 8-2 *Teaching* for information on teaching.

Procedure

Use the following procedure to jog.

- 1, 2, 3...** 1. Press the JOG Key to enter the JOG mode. The following display will appear.

CS1W-MC221/421, CV500-MC221/421 C200H-MC221

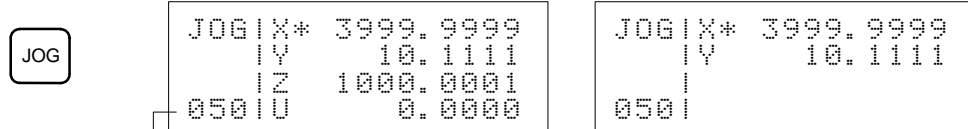

Indicates the override value (%).

The initial value is 50%. The value can be changed between 10% and 100% in 10% increments using the Up and Down Keys.

An asterisk (*) indicates that the origin has not been defined.

The value set in this step will not be cleared until the MC Unit power is turned OFF or the Teaching Box is disconnected.

2. Press one of the following jog feed keys:

For the CS1W-MC421 or CV500-MC421, use the following keys:

+X, -X, +Y, -Y, +Z, -Z, +U, -U

For the CS1W-MC221, CV500-MC221 or C200H-MC221, use the following keys:

+X, +Y, -X, -Y

The selected axis will be jogged and the present position on the display will be updated.

- Note**
1. The override value used here is valid only in the JOG mode.
 2. When the mode is changed, the override value that existed before selecting the JOG mode will become valid until the JOG mode is entered again.
 3. The operating feedrates are thus not affected by the change between RUN mode and JOG mode.

6-4 Handle Feeding

This operation is used to designate the axis and the MPG multiplication factor for handle feeding.

The MPG multiplication factor can be selected out of the four values registered in the system parameters.

To teach positions during handle feeding operations, press the TEACH Key where necessary.

Refer to 8-2 Teaching for information on teaching.

Procedure

Use the following procedure to execute handle feed operations.

- 1, 2, 3...** 1. Press the MPG Key to enter the MPG mode. The following display will appear.

CS1W-MC221/421, CV500-MC221/421

MPG

```

MPG I X   3999.9999
          |Y*   10.1111
          |X I Z  1000.0001
          |100 I U   0.0000
    
```

The present position of each axis is displayed in mm.
An asterisk (*) indicates that the origin has not been defined.

Indicates the axis to be fed.

The axis will not be displayed right after the MPG Key is pressed.

Press one of the following keys, and the selected axis will be displayed: +X, -X, +Y, -Y, +Z, -Z, +U, and -U Keys.

Use the following feed keys to change the axis being fed.

X axis: +X or -X Key Y axis: +Y or -Y Key

Z axis: +Z or -Z Key U axis: +U or -U Key

Indicates the multiplication factor for handle feeding. With the CS1W-MC221/421, the value of the numerator for the multiplication factor setting is displayed.

The multiplication factor will not be displayed right after the MPG Key is pressed.

Press an appropriate axis feed key (+X to -U), and the data registered in the system parameters for multiplication factor 1 will be displayed.

Any one of the four MPG multiplication factors registered in the system parameters can be used.

Select a desired factor using the Up and Down Keys.

System parameters

MPG multiplication factor 1
MPG multiplication factor 2
MPG multiplication factor 3
MPG multiplication factor 4

← Initially displayed

C200H-MC221

MPG

```

MPG I X   3999.9999
          |
          |X I
          |100 I
    
```

With the C200H-MC221, handle feeding can only be used for the X axis, therefore, the Y, Z, and U feeding keys are not valid.

Indicates the multiplication factor for handle feeding.

The multiplication factor will not be displayed right after the MPG Key is pressed.

Press an appropriate axis feed key (+X to -X), and the data registered in the system parameters for multiplication factor 1 will be displayed.

2. Turn the MPG connected to the MC Unit to feed the selected axis.

Note If turning the MPG by one scale unit feeds the axis the exact amount designated by the multiplication factor, use the following procedure to feed the axis.

- a) Stop the MPG (without turning it.)
- b) Press the MPG Key.
- c) Select a desired axis.
- d) Turn the MPG to feed the selected axis.

-  **Caution** In the following cases, turning the MPG by one scale unit may not feed the axis by the amount designated by the multiplication factor.
- While the MPG is being turned, the MPG Key is pressed to select an axis.
 - While the MPG is being turned, an axis other than the one currently being operated is selected.

SECTION 7

EXTENSION Mode Operations

This section explains how to change operation modes, how to use operations involving servo-lock and servo-unlock, memory protection, and operations for absolute encoders. Before attempting any of these operations, be sure to read the material covered in *7-1 EXTENSION Mode*.

7-1	EXTENSION Mode	62
7-2	Servo-lock/Unlock	63
7-3	Memory Protect/Release	65
7-4	Initial Setting of the Absolute Encoder	65
7-5	Software Reset of the Absolute Encoder	67
7-6	Origin Setting of the Absolute Encoder	68
7-7	Switching the Message Display (CS1W-MC221/421 Only)	69
7-8	Saving Data	70

7-1 EXTENSION Mode

This section provides an overview of EXTENSION mode operations and explains how to access the EXTENSION mode menu.

The following operations can be executed in the EXTENSION mode.

CV500-MC221/421

Operation	Function	Page
1. CHANGE MODE	Changes the control mode of the MC Unit. The control mode is initially set to the T.BOX LIMITED mode. The control mode must be changed when executing any operations other than monitoring.	33
2. SERVO LOCK	Locks the servo for a designated axis or for all axes.	63
3. SERVO FREE	Unlocks the servo for a designated axis or for all axes.	63
4. MEM PROTECT	Protects or frees the memory of the MC Unit.	65
5. ABS INIT SET	Performs initial settings for an absolute encoder.	65
6. ABS SOFT RSET	Performs a software reset for an absolute encoder.	67

C200H-MC221

Operation	Function	Page
1. CHANGE MODE	Changes the control mode of the MC Unit. The control mode is initially set to the T.BOX LIMITED mode. The control mode must be changed when executing any operation other than monitoring.	33
2. SERVO LOCK	Locks the servo for a designated axis or for all axes.	63
3. SERVO FREE	Unlocks the servo for a designated axis or for all axes.	63
4. MEM PROTECT	Protects or frees the memory of the MC Unit.	65
5. ABS INIT SET	Performs initial settings for an absolute encoder.	65
6. ABS SOFT RSET	Performs a software reset for an absolute encoder.	67
7. DATA SAVE	Saves position data, parameters, and program to flash memory.	70

CS1W-MC221/421

Operation	Function	Page
1. CHANGE MODE	Changes the control mode of the MC Unit. The control mode is initially set to the T.BOX LIMITED mode. The control mode must be changed when executing any operation other than monitoring.	33
2. SERVO LOCK	Locks the servo for a designated axis or for all axes.	63
3. SERVO FREE	Unlocks the servo for a designated axis or for all axes.	63
4. MEM PROTECT	Protects or frees the memory of the MC Unit.	65
5. ABS SETTING	Performs origin setting for an absolute encoder.	68
6. LANGUAGE	Switches display for Teaching Box messages between Japanese and English.	69
7. DATA SAVE	Saves position data, parameters, and program to flash memory.	70

For details on changing the control mode (1. CHANGE MODE), refer to 4-2 *Changing the MC Unit Control Mode*.

Procedure

Use the following procedure to access the EXTENSION mode menu.

1, 2, 3...

1. Press the EXT Key.

CV500-MC221/421

CS1W-MC221/421, C200H-MC221



```
EXTI 1/2
1. CHANGE MODE
2. SERVO LOCK
3. SERVO FREE
```

```
EXTI 1/3
1. CHANGE MODE
2. SERVO LOCK
3. SERVO FREE
```

Using the Up or Down Cursor Key, scroll up or down the menu.

CV500-MC221/421

C200H-MC221



```
EXTI 2/2
4. MEM PROTECT
5. ABS INIT SET
6. ABS SOFT RSET
```

```
EXTI 2/3
4. MEM PROTECT
5. ABS INIT SET
6. ABS SOFT RSET
```



```
EXTI 3/3
7. DATA SAVE
```



CS1W-MC221/421

```
EXTI 2/3
4. MEM PROTECT
5. ABS SETTING
6. LANGUAGE
```



```
EXTI 3/3
7. DATA SAVE
```

2. Press one of the numeric keys 1 to 6 (or 1 to 7) to select an operation.

Refer to the following sections for the procedures for individual operations.

3. Press the CLR Key after completing the selected operation.



The display will return to the EXTENSION mode menu.

7-2 Servo-lock/Unlock

This operation can be used to lock or unlock the servo for a selected axis or for all axes.

Procedure 1

Use the following procedure to lock the servo.

1, 2, 3...

1. Select "2. SERVO LOCK" from the EXTENSION mode menu.

CS1W-MC221/421, CV500-MC221/421

C200H-MC221



```
EXTI-SERVO LOCK-
| 0. ALL AXES
| 1. X 3. Z
| 2. Y 4. U
```

```
EXTI-SERVO LOCK-
| 0. ALL AXES
| 1. X
| 2. Y
```

2. Select the axis or axes for which servo-lock is to be executed.

In this example, all axes are selected.

0

```

EXTI-SERVO LOCK-
| OK?
ALL|
| YES / NO

```

Indicates selected axes as follows:

ALL: All axes; X: X axis; Y: Y axis; Z: Z axis; U: U axis

3. Press the YES Key to execute servo-lock.

When the operation has been completed, the following display will appear.

YES

```

EXTI-SERVO LOCK-
|
ALL| COMPLETE!
|

```

Procedure 2

Use the following procedure to unlock the servo.

1, 2, 3...

1. Select "3. SERVO FREE" from the EXTENSION mode menu.

CS1W-MC221/421, CV500-MC221/421 C200H-MC221

3

```

EXTI-SERVO FREE-
| 0. ALL AXES
| 1. X 3. Z
| 2. Y 4. U

```

```

EXTI-SERVO FREE-
| 0. ALL AXES
| 1. X
| 2. Y

```

2. Select the axis or axes for which servo-unlock is to be executed.

In this example, all axes are selected.

0

```

EXTI-SERVO FREE-
| OK?
ALL|
| YES / NO

```

Indicates selected axes as follows:

ALL: All axes; X: X axis; Y: Y axis; Z: Z axis; U: U axis

3. Press the YES Key to execute servo-unlock.

When the operation has been completed, the following display will appear.

YES

```

EXTI-SERVO FREE-
|
ALL| COMPLETE!
|

```

7-3 Memory Protect/Release

This operation can be used to protect or release the memory protection in the MC Unit.

Procedure

Use the following procedure to protect or release memory protection.

- 1, 2, 3... 1. Select "4. MEMORY PROTECT" from the EXTENSION mode menu.

4

```
EXTI-MEM PROT-
|PROTECTED
|
|SWITCH: ↑, ↓
```

The initial setting is for the memory to be protected.

2. Select "protected" or "released" using the Up or Down Key.

When the Up or Down Key is pressed, the display will toggle between "protected" and "released."

Note If the TEACH Key is pressed while the memory is protected, the following display will appear.

```
POSITION DATA IS
PROTECTED.
RELEASE THE PRO-
TECT AND PROCEED
```

Press the CLR Key to return to the previous display.

7-4 Initial Setting of the Absolute Encoder

This operation is used to perform initial setting for the absolute encoder for a specific axis or all axes.

Note This procedure is only supported for the CV500-MC221/421 and C200H-MC221.

The compensation value for the absolute encoder is read, and the present position is moved to the mechanical origin (absolute value "0"). Use this procedure to write the initial settings values for the absolute encoder into the system parameters.

Initial setting is used at the following times:

- When changing the mechanical origin.
- When using a Servodriver with an absolute encoder for the first time.
- When present position values are lost due to battery discharge during normal operation.
- When the absolute encoder malfunctions.
- When replacing a Servomotor mounted with an absolute encoder.

Note For details regarding the operations necessary to set multiple rotation data for the absolute encoder to "0," refer to the relevant Servodriver manual.

The initial settings procedure is used at the Servodriver (OMRON U Series), immediately after setup.

When this procedure is performed, the position at which an axis using the absolute encoder is at rest will be registered as the mechanical origin.

Once the mechanical origin has been established, it will never be necessary to perform initial settings again. As a safety precaution, this function can be protected by setting DIP switch pin1 on the MC Unit to ON. In this protected state, if an attempt to perform this function is made, an error will be generated.

This procedure has the following restriction:

Initial setting cannot be performed if the present position registered in the absolute encoder has an absolute value exceeding 32,767 pulses.

After setup, if the motor is rotated, the value may exceed 32,767 pulses. In this case, perform the initial setting procedure once again after either setting up the Servodriver again, or moving the motor close to the position after setup.

Note Before performing this procedure, it is necessary to set DIP switch pin 1 on the MC Unit to OFF.

If "5.ABS INIT SET" is selected in EXTENSION mode with DIP switch pin 1 ON, the following display will appear:

```

TURN OFF
DIP SW No.1 AND
THEN PROCEED.
    
```

Press the CLR Key to return to the EXTENSION mode menu. After releasing memory protection by selecting "4.MEM PROTECT," re-attempt the procedure.

Procedure

Use the following procedure to perform initial setting for an absolute encoder.

Note After completion of initial setting, as a safety precaution, perform backup for the system parameters using MC Support Software.

- 1, 2, 3... 1. Select "5.ABS INIT SET," from the EXTENSION mode menu.
 CV500-MC221/421 C200H-MC221

5

```

EXTI-ABS IN SET-
| 0. ALL AXES
| 1. X      3. Z
| 2. Y      4. U
    
```

```

EXTI-ABS IN SET-
| 0. ALL AXES
| 1. X
| 2. Y
    
```

2. Select the axis or axes for which servo-unlock is to be executed.
 In this example, all axes are selected.

0

```

EXTI-ABS IN SET-
| OK?
ALL|
| YES / NO
    
```

Indicates selected axes as follows:
 ALL: All axes; X: X axis; Y: Y axis; Z: Z axis; U: U axis

3. Press the YES Key to perform initial setting.
 The initial setting values will be read into the system parameters.
 When the operation has been completed, the following display will appear.

YES

```

EXTI-ABS IN SET-
|
ALL| COMPLETE!
|
    
```

This display will appear even if initial setting is accidentally performed for an axis not using an absolute encoder. In this case, however, the initial setting values will not be read into the system parameters.

Note When using the C200H-MC221, the initial setting values will be stored in the internal memory. For this reason, if the power supply for the MC Unit is turned OFF, the initial setting will return to the original values. Save the parameters by writing them to flash memory.

7-5 Software Reset of the Absolute Encoder

This operation is used to set the present position for a specific axis or all axes using an absolute encoder tentatively to "0."

Note This procedure is only supported for the CV500-MC221/421 and C200H-MC221.

This operation is used to set the offset value to the system parameters. This operation is used when incrementing the mechanical origin established using the initial setting procedure. With a software reset, it is not necessary to perform set-up at the Servodriver as it is when performing initial setting.

As with initial setting, once the mechanical origin is established, it will never be necessary to perform it again. As a safety precaution, this function can be protected by setting DIP switch pin 1 on the MC Unit to ON. In this protected state, if an attempt to perform this function is made, an error will be generated.

This procedure has the following restriction:

A software reset cannot be performed if the present position has an absolute value exceeding 32,767 pulses. In this case, if this procedure is attempted, an error will be generated.

- Note**
1. This operation is used when performing incrementing after permanently setting the absolute value to "0" in the absolute encoder initial settings.
 2. Before performing this procedure, it is necessary to set DIP switch pin 1 on the MC Unit to OFF.

If "6.ABS SOFT RSET" is selected in EXTENSION mode with DIP switch pin 1 ON, the following display will appear:

```
TURN OFF
DIP SW No. 1 AND
THEN PROCEED.
```

Press the CLR Key to return to the EXTENSION mode menu. After releasing memory protection by selecting "4.MEM PROTECT," re-attempt the procedure.

Procedure

Use the following procedure to perform a software reset for an absolute encoder.

Note After completion of a software reset, as a safety precaution, perform backup for the system parameters using MC Support Software.

- 1, 2, 3...**
1. Select "6.ABS SOFT RSET," from the EXTENSION mode menu.

CV500-MC221/421

C200H-MC221

6

```
EXTI-ABS SF RST-
| 0. ALL AXES
| 1. X 3. Z
| 2. Y 4. U
```

```
EXTI-ABS SF RST-
| 0. ALL AXES
| 1. X
| 2. Y
```

2. Select the axis or axes for which the servo is to be unlocked.
In this example, all axes are selected.

0

```
EXTI-ABS SF RST-
| OK?
ALL|
| YES / NO
```

Indicates selected axes as follows:

ALL: All axes; X: X axis; Y: Y axis; Z: Z axis; U: U axis

- Press the YES Key to perform a software reset.
The offset values will be read into the system parameters.
When the operation has been completed, the following display will appear.

YES

```
EXTI-ABS SF RST-
|
ALL COMPLETE!
```

This display will appear even if a software reset is accidentally performed for an axis not using an absolute encoder. In this case, however, the offset values will not be read into the system parameters.

Note When using the C200H-MC221, the offset values will be stored in the RAM. For this reason, if the power supply for the MC Unit is turned OFF, the a software reset values will return to the original values. Save the parameters by writing them to flash memory.

7-6 Origin Setting of the Absolute Encoder

This operation is used to set the origin for the absolute encoder for a specific axis or all axes.

Note This procedure is only supported for the CS1W-MC221/421.

After completion of origin search, or after moving the axis to the position desired as the origin using jogging operation, by performing origin setting for the absolute encoder, the position at which the axis is at rest is registered in the MC Unit as the absolute position of the origin.

More specifically, the procedure involves reading the absolute encoder value for the mechanical origin, and writing it into the mechanical position parameter as an absolute position setting. After this setting has been made, the absolute position value will be deducted from values read in after servo-lock, giving the present position and making origin search unnecessary. Further, when performing origin search, the offset value for the origin (the standard origin offset value) can also be set.

Absolute origin setting is used at the following times:

- When changing the mechanical origin.
- When using a Servodriver with an absolute encoder for the first time.
- When present position values are lost due to battery discharge during normal operation.
- When the absolute encoder malfunctions.
- When replacing a Servomotor mounted with an absolute encoder.

- Note**
- For details regarding the operations necessary to set multiple rotation data for the absolute encoder to "0," refer to the relevant Servodriver manual.
 - Before performing this procedure, release memory protection in EXTENSION mode.

If "5. ABS SETTING" is selected in EXTENSION mode, with memory protection enabled, the following message will be displayed:

```
FLASH MEMORY IS
PROTECTED.
RELEASE THE PRO-
TECT AND PROCEED
```

Press the CLR Key. The EXTENSION mode menu will be returned. After releasing memory protection by selecting "4. MEMORY PROTECT," re-attempt the operation.

Procedure

Use the following procedure to perform origin setting for an absolute encoder.

Note After completion of ABS origin setting, as a safety precaution, perform backup for the system parameters using CX-Motion.

- 1, 2, 3... 1. Select "5. ABS SETTING," from the EXTENSION mode menu.

5

```

EXTI-ABS SET-
| 0. ALL AXES
| 1. X      3. Z
| 2. Y      4. U
  
```

2. Select the axis or axes for which servo-unlock is to be executed.
In this example, all axes are selected.

0

```

EXTI-ABS SET-
| OK?
ALL|
| YES / NO
  
```

Indicates selected axes as follows:

ALL: All axes; X: X axis; Y: Y axis; Z: Z axis; U: U axis

3. Press the YES Key to perform origin setting.
The absolute encoder values will be written into the system parameters.
When the operation has been completed, the following display will appear.

YES

```

EXTI-ABS SET-
|
ALL| COMPLETE!
|
  
```

This display will appear even if origin setting is accidentally performed for an axis not using an absolute encoder. In this case, however, the absolute encoder values will not be written into the system parameters.

Note When using the CS1W-MC221/421, the absolute position settings will be stored in the internal memory. For this reason, if the power supply for the MC Unit is turned OFF, the absolute position settings will return to the original values. Save the parameters by writing them to flash memory.

7-7 Switching the Message Display (CS1W-MC221/421 Only)

This operation is used to switch the message display for the Teaching Box between English and Japanese.

The factory setting is for English display.

After selecting "MC Series" as the connected device, press the CLR Key to display the online connections initialization screen, and make the setting in EXTENSION mode.

 **Caution** Do not change the display language while the program is being executed or while a motor is moving. Unexpected operation can result.

Procedure

Use the following procedure to switch the language for the message display.

- 1, 2, 3... 1. Select "6. LANGUAGE," from the EXTENSION mode menu.

```

EXTI-LANGUAGE-
| JAPANESE
|
| SWITCH: ↑, ↓
  
```

2. Use the Up/Down Cursor Key to select English or Japanese as desired.

```
EXT | -LANGUAGE-
    | ENGLISH
    |
    | SWITCH: ↑, ↓
```

3. Press the WRITE Key. From now on, messages will be displayed in the language selected.

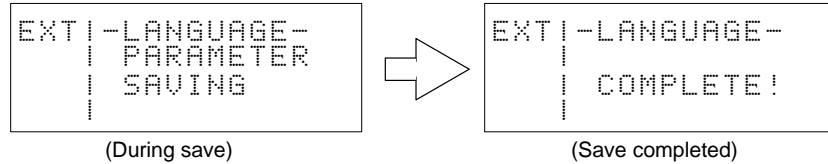

7-8 Saving Data

This procedure is used to save position data, parameters, and programs to flash memory. It can only be used with the CS1W-MC221/421 and C200H-MC221 MC Units.

The various kinds of data that are saved using this operation are copied from the flash memory to internal memory after a power-up or restart. This data in internal memory is controlled during normal operation. In addition, position data or parameters that are changed using the teaching or monitoring operations are also stored in internal memory.

This operation saves the data from internal memory to flash memory. Be sure to use it when changing position data, parameters, etc.

Procedure

Use the following procedure to write data to flash memory.

1, 2, 3... 1. Select "7. DATA SAVE" from the EXTENSION mode menu.

7

```
EXT | -DATA SAVE-
    |
    | 0. ALL 2. PRG
    | 1. PRM 3. DAT
```

2. Select the type of data.
In this example, "all data" is selected.

0

```
EXT | -DATA SAVE-
    | OK?
    | ALL
    | YES / NO
```

Indicates selected data as follows:
ALL: All data
PRM: Parameters
PRG: Program
DAT: Position data

3. Press the YES Key.
When the operation has been completed, the following display will appear.

YES

```
EXT | -DATA SAVE-
    |
    | ALL
    | COMPLETE!
```

This message will appear even if the content of the data to be saved is the same as the data already in flash memory (i.e., if the data has not changed).

Note If the data fails when writing to flash memory, the following message will appear.

```
AN ERROR HAS OC-  
CURRED BY FLASH-  
MEMORY.
```

Press the CLR Key to return to the menu display in step 1.

Press the CLR Key. The EXTENSION mode menu will be returned. After releasing memory protection by selecting "4. MEMORY PROTECT," re-attempt the operation.

SECTION 8

Direct Functions

This section describes procedures for changing the override value and for teaching. The functions described in this section can be executed in any control mode.

8-1	Changing the Override Value	74
8-2	Teaching	75

8-1 Changing the Override Value

This operation can be used to change the override value for each axis. The current override value is displayed for each axis in real time.

Procedure

Use the following procedure to change the override value.

- 1, 2, 3... 1. Press the OVERRIDE Key.



CS1W-MC221/421, CV500-MC221/421

[OV]X	100.0
Y*	50.0
Z	100.0
U	50.0

C200H-MC221

[OV]X	100.0
Y*	50.0

An asterisk (*) indicates that the origin has not been defined.

Pressing the CLR Key from this initial display will return it to the previous mode.

2. Press the CHG Key.



CS1W-MC221/421, CV500-MC221/421

[OV]X	100.0
Y*	50.0
Z	100.0
U	50.0

C200H-MC221

[OV]X	100.0
Y*	50.0

The cursor appears.

3. Using the Up and Down Keys, move the cursor to the value to be changed. In this example, the cursor is moved to the Y axis value.



CS1W-MC221/421, CV500-MC221/421

[OV]X	100.0
Y*	50.0
Z	100.0
U	50.0

C200H-MC221

[OV]X	100.0
Y*	50.0

4. Using the numeric Keys, input a new override value between 0.1 and 199.9. In this example, 111.5 is input.

1

1

1

.

5

CS1W-MC221/421, CV500-MC221/421

[OV]X	100.0
Y*	111.5
Z	100.0
U	50.0

C200H-MC221

[OV]X	100.0
Y*	111.5

If a wrong value is input, press the CLR Key. The previous override value will return.

5. Press the WRITE Key to set the newly input data.

8-2 Teaching

This operation can be used to teach position data.

Positions set by jogging or handle feeding can be written into designated addresses using this operation.

Note This operation cannot be executed if the present position has not been defined or if the memory of the MC Unit is protected. Release the memory protection to execute this function. If an attempt is made to execute the function while the memory is protected, the following message will be displayed.

```

POSITION DATA IS
PROTECTED.
RELEASE THE PRO-
TECT AND PROCEED
    
```

Press the CLR Key to return to the previous display.

For instructions on releasing the memory protection, refer to 7-3 Memory Protect/Release.

Procedure

Use the following procedure to teach position data

- 1, 2, 3... 1. Press the TEACH Key.

The present position of the axes controlled by task 1 are displayed.

TEACH

CS1W-MC221/421, CV500-MC221/421

```

[TH]X      100.00
  Y        1000.0
TK1 Z      1111.0
0000U      1111111
    
```

C200H-MC221

```

[TH]X      100.00
  Y        1000.0
TK1
0000
    
```

The present position is updated in realtime.

Indicates the task number.

Press the TASK CHG to select another task number.

Indicates the address of the first position data.

Use numeric keys to change the address if desired.

The setting range is from 0 to 1999.

The address will not be accepted when the WRITE Key is pressed if it is not between the first and last addresses set as memory control parameters in the system parameters.

Press the CLR Key to return the display to the previous address.

2. Press the WRITE Key.

WRITE

CS1W-MC221/421, CV500-MC221/421

```

[TH]      A0000=X
          A0001=Y
TK1      A0002=Z
0000 Y/N?A0003=U
    
```

C200H-MC221

```

[TH]      A0000=X
          A0001=Y
TK1
0000 Y/N?
    
```

The address where position data is stored will be displayed for each axis.

3. Press the YES Key to write the position data.

YES

CS1W-MC221/421, CV500-MC221/421

```
[TH]X      100.00
      Y      1000.0
TK1 Z      1111.1
0004      1111111
```

C200H-MC221

```
[TH]X      100.00
      Y      1000.0
TK1
0002
```

Indicates the address of the next position data.

Position data is stored in series for the axes controlled by one task.

The following example shows the memory addresses when the X and Y axes are controlled by task 1.

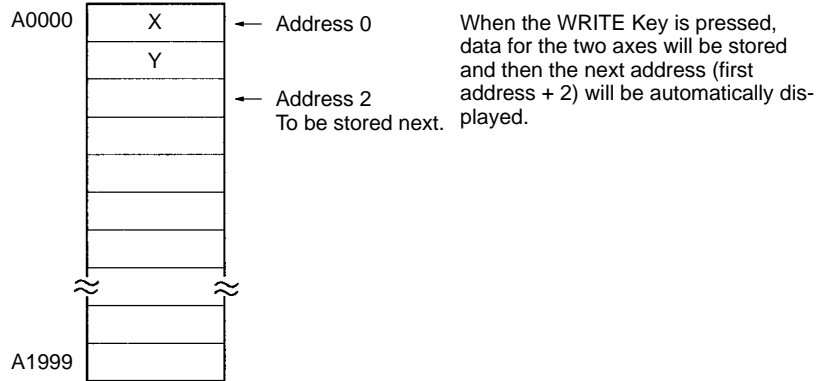

SECTION 9

Other Operations

This section explains how to execute deceleration stops and reset errors.

9-1	Deceleration Stop	78
9-2	Error Resetting	78

9-1 Deceleration Stop

This operation can be used to decelerate and stop all axes and, at the same time, to stop program execution.

Caution Before executing a deceleration stop, be sure that it will not affect the equipment.

Note A deceleration stop is treated as a system error. After pressing the DEC STOP Key, reset the error. Unless the error is reset, other operations cannot be executed. For instructions on resetting errors, refer to 9-2 *Error Resetting*.

Procedure

Use the following procedure to execute a deceleration stop.

- 1, 2, 3... 1. Press the DEC STOP Key.



```
<<< ERROR >>>
SYS: ERR0010
DECEL STOP
```

2. Press the CLR Key.

```
[ST]
ALL TASKS STOP !
```

3. Press the CLR Key to return to the MONITOR mode.

9-2 Error Resetting

This operation can be used to reset errors in the MC Unit or the Servodriver.

Caution Before resetting an error, be sure that it will not affect the equipment.

Procedure 1

Use the following procedure to reset an error which has occurred in the MC Unit.

- 1, 2, 3... 1. Press the ERR CLR Key.



```
[RT]
1. MC UNIT
2. DRIVER
```

2. Press the 1 Key.



```
[RT] MC UNIT
RESET ERROR ?
YES / NO
```

3. Press the YES Key.

The error will be reset only for the task where it has occurred.



```
[RT] MC UNIT
ERROR RESET !
```

Procedure 2

Use the following procedure to reset an error in the Servodriver.

- 1, 2, 3... 1. Select "2. DRIVER" from the menu shown in step 1. in procedure 1.

CS1W-MC221/421, CV500-MC221/421 C200H-MC221

2

```
[RT]          DRIVER
              0. ALL AXES
              1. X      3. Z
              2. Y      4. U
```

```
[RT]          DRIVER
              0. ALL AXES
              1. X
              2. Y
```

2. Using the 0 to 4 Keys, select an axis for which to reset the error.
In this example, all axes are selected.

```
[RT]          DRIVER
              <ALL AXES>
              RESET ERROR ?
              YES / NO
```

Indicates the axes selected.
0: All axes; 1: X axis; 2: Y axis; 3: Z axis; 4: U axis

3. Press the YES Key to reset the error for the selected axes.



YES

```
[RT]          DRIVER
              ERROR RESET !
```

Appendix A

Standard Models

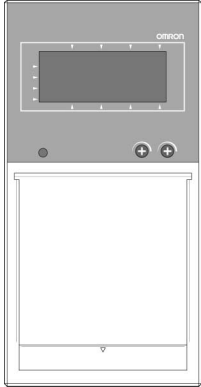
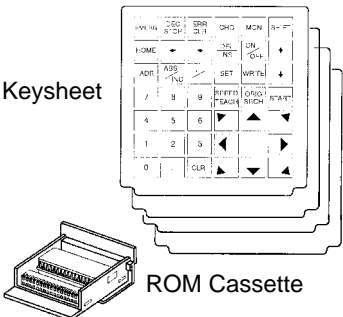
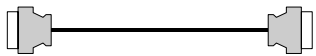
The Teaching Box can be connected to and used for a Motion Control Unit, Position Control Unit, or Position Driver. The following table shows the products required for each.

Connected unit	MC Unit	PC Unit	Position Driver
Teaching Box 	Any one of the following: CVM1-PRO01-V1 (Without ROM Cassette) CVM1-PRS21-□□□ (with CV Programming Console ROM Cassette) CVM1-PRS71 (with MC Unit ROM Cassette, see note) Note: The CVM1-PRS71 is not longer being manufactured. Use the CVM1-PRO01-V1.		
ROM Cassette Keysheet 	CVM1-MP702-V1 (Can be used with MC Units, PC Units, or Position Drivers.)	CVM1-MP702-V1 (Can be used with MC Units, PC Units, or Position Drivers.) CVM1-MP703-V1 (Position Drivers only)	
Applicable devices	CV500-MC421 CV500-MC221 CS1W-MC421 CS1W-MC221 C200H-MC221	C500-NC222-E 3G2A5-NC111-EV1	FND-X-series Position Driver
Connecting Cable 	Any one of the following: CV500-CN224 (2 m) CV500-CN424 (4 m) CV500-CN624 (6 m)		Any one of the following: CV500-CN22A (2 m) CV500-CN42A (4 m) CV500-CN62A (6 m)
Conversion Adaptor 	Not used.	CV500-CIF11 (NC111-EV1) CV500-CIF21 (NC222-E)	Not used.
Applicable Manual	This Manual	CVM1-PRO01-V1 Teaching Box (For Position Control Units) Operation Manual (W321)	CVM1-PRO01-V1 Teaching Box For Position Drivers Operation Manual (W354)

Note The CVM1-PRS21-□□□ Programming Console can be used as a Teaching Box for Motion Control Units by replacing the ROM Cassette and Keysheet. Purchase a CVM1-MP702-V1 ROM Cassette. The CVM1-PRS71 MC Unit Teaching Box can also be used for Position Control Units and Position Drivers if a CVM1-MP702-V1 ROM Cassette is used.

Appendix B

Error Displays and Error Processing

The error messages and probable causes and remedies are shown in the following table.
The buzzer will sound when the message is displayed.

No.	Messages	Causes and Remedy
1	POSITION DATA IS PROTECTED. RELEASE THE PROTECT AND PROCEED	One of the following operations was performed with the memory protected. The TEACH Key was pressed. The WRITE Key was pressed. Switch to the EXTENSION mode and release the memory protection. See <i>Section 7-3</i> .
2	TURN OFF DIP SW No.1 AND THEN PROCEED.	Only for the CV500-MC221/421 and C200H-MC221. One of the absolute encoder functions in the EXTENSION mode was selected with pin 1 on the DIP switch of the MC Unit turned ON. Turn OFF pin 1 on DIP switch of the MC Unit.
4	AN ERROR HAS OCCURRED. RESET ERROR AND THEN PROCEED.	An attempt was made to execute a function other than monitoring or a deceleration stop while an error message was displayed. Reset the error. See <i>Section 9-2</i> . Data can be written to the flash memory, even when an error occurs.
5	CHANGE TO T.BOX ENABLED OR T.BOX RESERVED MODE AND PROCEED.	An attempt was made in the T.BOX LIMITED mode to execute a function that can be executed only in the T.BOX ENABLED or T.BOX RESERVED mode. Change the mode to either T.BOX ENABLED or T.BOX RESERVED. See <i>Section 4-2</i> .
6	PUT ALL AXES IN SERVOFREE STATUS AND THEN PROCEED	An attempt was made to change the D/A output or output signal with the servo locked. Free the servo for all axes. See <i>Section 7-2</i> .
7	SYSTEM PARAMETERS ARE CORRUPTED. DOWNLOAD SYSTEM PARAMETER	The system parameters are corrupted for some unknown reason. Download the system parameters using the MC Support Software or CX-Motion. After downloading, restart the MC Unit or reset the power. No operation will be possible while this message is displayed.
8	ORIGIN IS NOT ESTABLISHED. ESTABLISH ORIGIN AND THEN PROCEED	An attempt was made to teach the current position without establishing the origin. Establish the origin for all axes controlled by the task and then proceed.
9	PUT THE AXIS IN SERVOLOCK STATUS AND THEN PROCEED	An attempt was made to execute MPG feeding or jogging without locking the servos. Lock the servos for the designated axes and then proceed.
10	AN ERROR HAS OCCURRED BY FLASH-MEMORY.	Only for the CS1W-MC221/421 and C200H-MC221. An error has occurred in the flash memory of the MC Unit. Repeat the operation. If the same error occurs again, replace the MC Unit.
11	FLASH MEMORY IS PROTECTED. RELEASE THE PROTECT AND PROCEED	An attempt was made to write data to the flash memory while the memory was protected. Switch to the EXTENSION mode and release the memory protection. See <i>Section 7-3</i> .
	<<EEPROM ERROR>>	The CVM1-PRO01-V1 or CVM1-PRS21-EV2 was operated with a CVM1-MP702 ROM Cassette mounted. Replace the CVM1-MP702 with a CVM1-MP702-V1 ROM Cassette. Note This error will appear when the Teaching Box power is turned ON, but the buzzer will not sound.

Appendix C

Specifications and External Dimensions

General specifications and external dimensions are given below.

General Specifications

Item	Specifications
Power supply	300 mA max. at 5 VDC ^{+5%/} _{-10%} , (Supplied from the MC Unit.)
Ambient operating temperature	0°C to 55°C
Ambient operating humidity	10% to 90% RH (no condensation)
Ambient operating atmosphere	No corrosive gasses
Storage temperature	-20°C to 75°C
Display	Semi-transmissive liquid crystal display (with LED) 16 characters x 4 rows; 5 x 7 dots/character
Weight	400 g
External dimensions	192 x 96 x 48.5 mm (H x W x D)

External Dimensions (Unit: mm)

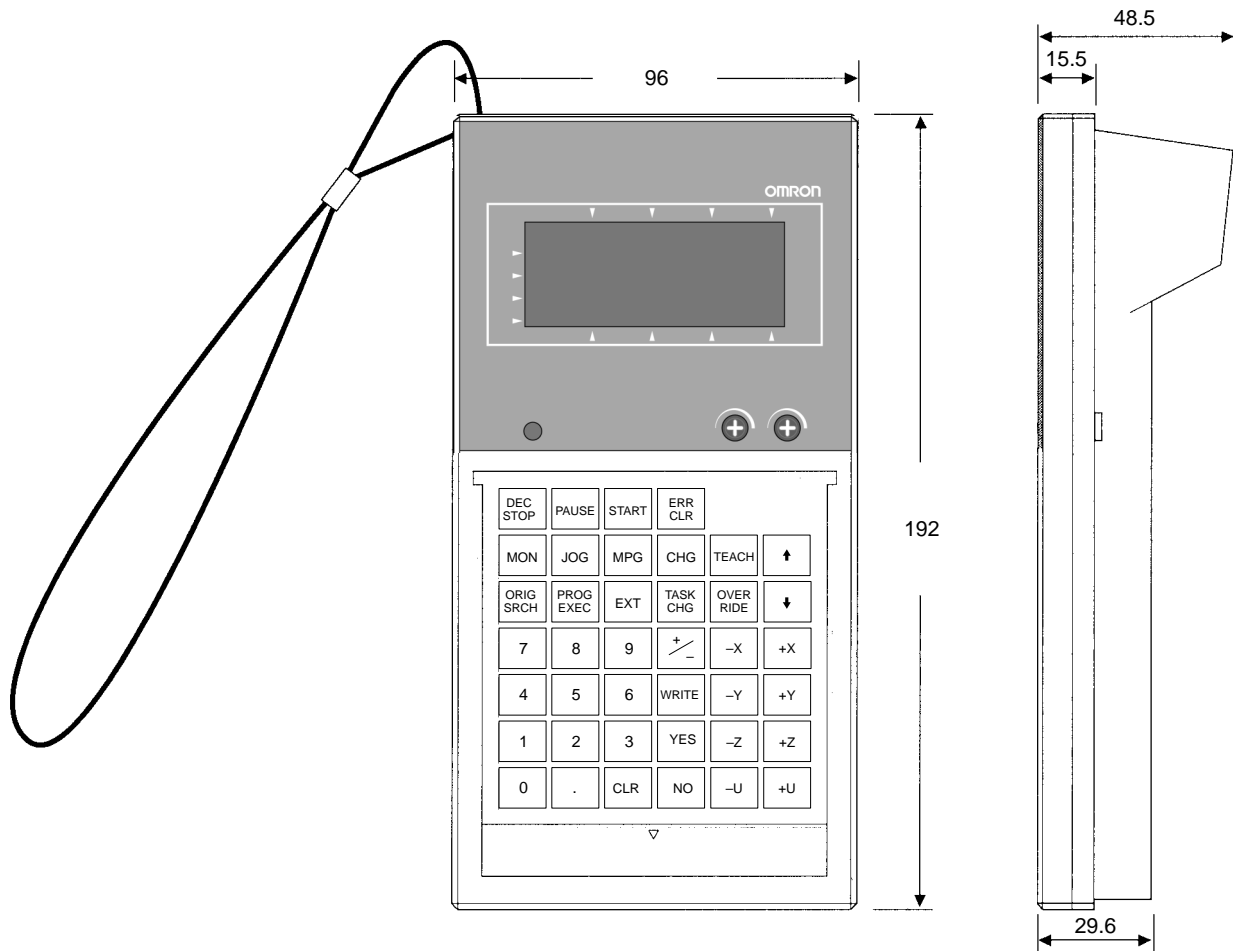

Index

A–B

- absolute encoder
 - initial setting, 65
 - origin setting, 68
 - soft reset, 67
- analog outputs
 - changing, 46
 - monitoring, 45
- applications, 2
- axes for operation, 16
- axis
 - changing override value, 74
 - decelerate/stop, 78
 - displays, 37
 - jogging, 57
 - origin search, 54
 - servo lock, 63
- basic input operations, 36
 - buzzer operation, 37
 - cursor displays, 37
 - inputting numeric values, 36
 - returning to previous display, 36
 - setting input values, 36

C

- C200H-MC221
 - changing display language, 29
 - operations, 9
 - restricted functions, 20
- changing
 - display language, 27
 - I/O signals, 44
 - override value, 74
 - position data, 47
 - servo parameters, 49
- compatibility, 2
- connected model, selecting, 26
- connecting to MC Unit, 22
 - attaching Keysheet, 22
 - cables, 22
 - installing ROM Cassette, 22
 - procedure, 23
- connection
 - MC Unit, 4
 - Teaching Box, 3
- CS1W-MC221
 - changing display language, 27
 - operations, 7
 - restricted functions, 18
- CS1W-MC421
 - changing display language, 27

- operations, 7
- restricted functions, 18
- CV500-MC221
 - changing display language, 28
 - operations, 8
 - precautions, 12
 - restricted functions, 19
- CV500-MC421
 - changing display language, 28
 - operations, 8
 - restricted functions, 19

D

- deceleration stop, 78
- direct functions, 35, 73
 - changing override value, 35
 - teaching position data, 35
- display language, changing, 27

E

- error data displays, 46
- error displays, 83
- error messages, handling, 37
- error processing, 83
- error reset, 78
- errors
 - clearing and resetting, 38
 - reset, 78
- EXTENSION mode, 62
 - possible operations
 - C200H-MC221, 62
 - CS1W-MC221/421, 62
 - CV500-MC221/421, 62
- external dimensions, 85

F

- features, 2
- flash memory, 70
- functions, 10

G–I

general specifications, 85
handle feeding, 58
I/O signals
 changing, 44
 monitoring, 44
initial operation, 32
input signals, monitoring, 44
installing in a panel, 24

J–L

jogging, 57
key arrangement, 10
key functions, 11
language, messages, changing, 69

M

MC programs, 16
MC Unit
 absolute encoder
 initial setting, 65
 origin setting, 68
 soft reset, 67
 error reset, 78
 memory protection, release/protect, 65
MC Unit Control Modes, 16
 changing, 33
 T.BOX ENABLED, 17, 33
 T.BOX LIMITED, 17, 33
 T.BOX RESERVED, 17, 33
memory protect/release, 65
MONITOR mode, 42
monitoring
 I/O signals, 44
 position data, 47
 present position, 43
 servo parameters, 49
 Z-phase tolerance, 48
motion control, axes, 16
MPG multiplication factor, 58

O

operating procedure, 13
operations, 7
 basic input, 36
origin search, 54
origin setting, absolute encoder, 68

output signals
 changing, 45
 monitoring, 45
override value, changing, 74

P

parts, 10
position data
 changing, 47
 monitoring, 47
 teaching, 75
precautions
 application, xiii
 general, xi, xii
 operating environment, xii
present position, monitoring, 43
program execution, 55
 block run, 55
 cycle run, 55
 stop, 78

R–S

restricted functions, 18
saving data to flash memory, 70
servo lock, 63
servo parameters
 changing, 49
 monitoring, 49
servodriver, error reset, 79
soft reset, absolute encoder, 67
specifications, 85
standard models, 81
system configuration, 3

T

T.BOX ENABLED mode, 17
T.BOX LIMITED mode, 17
T.BOX RESERVED mode, 17
table of operations, 39
task displays, 37
tasks, 16
teaching, 75
Teaching Box
 installing in a panel, 24
 summary of operations, 39
Teaching Box modes
 changing, 35
 MONITOR, 35

Revision History

A manual revision code appears as a suffix to the catalog number on the front cover of the manual.

Cat. No. W320-E1-03

↑
Revision code

The following table outlines the changes made to the manual during each revision. Page numbers refer to the previous version.

Revision code	Date	Revised content
1	June 1997	Original production
2	May 1999	Information on the CS1-series CS1W-MC421/MC221 Motion Control Units, FND-X-series Position Driver, and absolute encoders added throughout the manual.
03	August 2002	Page ix, 2, 81, 83, and 85: Changes made for new versions of the Units.