

## F3SN-A□□□□P□□ Series Safety Light Curtain

### Instruction Manual

---

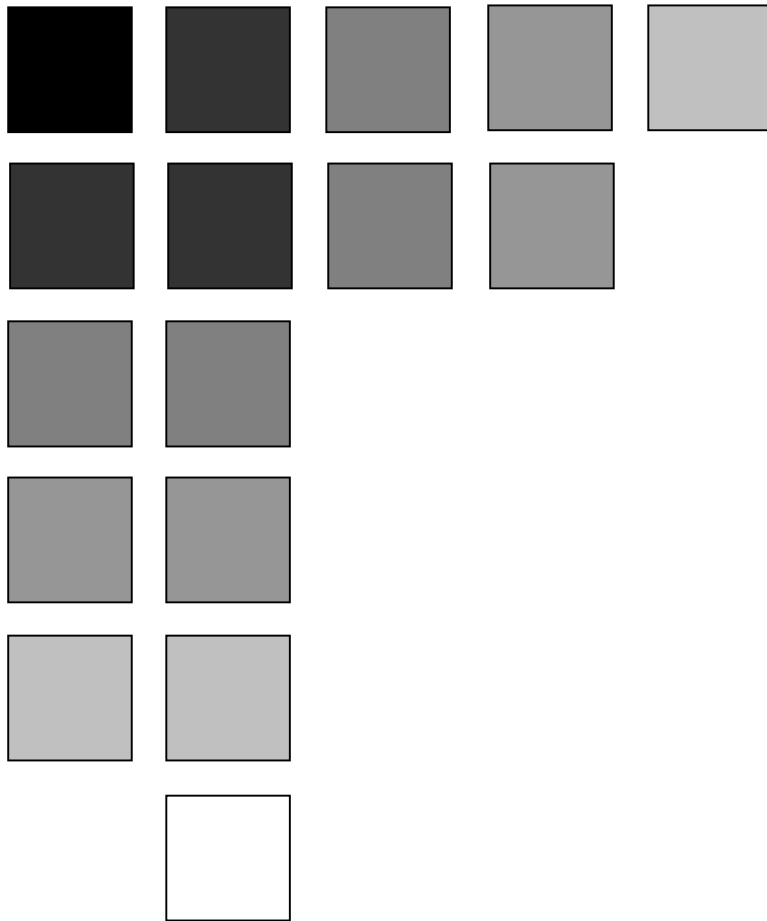

*TYPE 4*  
*PNP Output Type*

## Introduction

Thank you for purchasing the F3SN-A Series Safety Light Curtain (hereinafter referred to as "the F3SN-A").

This is the Instruction Manual describing the use of the F3SN-A.

Always heed the following points when using the F3SN-A:

- Read this manual thoroughly and be sure you understand the information provided before attempting to operate the F3SN-A.
- It is assumed that the F3SN-A will be used properly according to the installation environment, performance and function of the machine. Qualified personnel should conduct risk assessment on the machine and determine the suitability of this product before installation.
- Make sure that the personnel operating the F3SN-A are knowledgeable about its' operation and the machine on which it is installed.
- Keep the manual in a secure and convenient location and refer to it as necessary.

### Regulations and Standards

1. The F3SN-A has not received the type approval provided by Article 44-2 of the Industrial Safety and Health Law of Japan. Therefore, it cannot be used in Japan as a safety device for pressing or shearing machines provided by article 42 of that law.
  2. (1) The F3SN-A is electro-sensitive protective equipment (ESPE) in accordance with European Union (EU) Machinery Directive Annex IV, B, Safety Components, Item 1.  
(2) The F3SN-A complies with the following regulations and standards:
    1. EU regulations
      - Machinery Directive: Directive 98/37/EC
      - EMC Directive: Directive 89/336/EEC
    2. European standard: EN61496-1 (TYPE 4 ESPE)
    3. International standard: IEC61496-1 (TYPE 4 ESPE), IEC61496-2 (TYPE 4 AOPD)
  - (3) The F3SN-A received the following approvals from the EU accredited body DEMKO A/S:
    - EC Type-Examination in accordance with the EU Machinery Directive
    - Certificate of a Competent Body for EMC
    - DEMKO Type Approval TYPE 4 ESPE (EN61496-1)  
TYPE 4 AOPD (IEC61496-2)  
Use: EN954-1 Category B, 1, 2, 3, 4
  - (4) The F3SN-A received the following approvals from the Third Party Assessment Body UL:
    - Certificate of UL listing for US and Canadian safety standards  
Both of which are: TYPE 4 ESPE (IEC61496-1)  
TYPE 4 AOPD (IEC61496-2)
    - Certificate of Programmable System (UL1998, IEC61496-1)
3. The F3SN-A is designed according to the following standards. To make sure that the F3SN-A complies with the following standards and regulations, you are asked to design and use it as provided by any other related standards, laws, and regulations.  
Consult UL or other standardization bodies if you have any questions.
    - EN415-4, prEN691, EN692, prEN693 (European standard)
    - OSHA 29 CFR 1910.212 (US Industrial Safety and Health Regulation)
    - OSHA 29 CFR 1910.217 (US Industrial Safety and Health Regulation)
    - ANSI B11.1~B11.19 (US standard)
    - ANSI/RIA 15.06 (US standard)

## Notice

**Give sufficient safety considerations and make enough allowance with regard to ratings and functions of the system when using the F3SN-A under following conditions:**

- (1) Conditions or environment not specified in this manual
- (2) Applications to devices and facilities requiring special safety precautions, such as; nuclear energy control, railway, aircraft, vehicles, combustion facility, medical system, space development, large amusement machines, etc.)

## Precaution on Safety

### ● General conventions for safe use

The following conventions are used for precautionary items in this manual in order to ensure safe and proper use of the F3SN-A. Items listed here are critical for safety and must be heeded at all times.



### WARNING

Indicates a potentially hazardous situation, which, if not avoided, could result in death or serious injury.



Indicates prohibited actions.



### WARNING

After setting the fixed blanking, check that the F3SN-A detects a test rod at any position in the detection zone through which a person can reach the hazardous part of the machine. If any positions are found by check above, install protective structures to prevent intrusion, which the F3SN-A can not detect. Failure to do so may result in serious injury. (Chapter 1-2)

Use of the floating blanking increases the size of the detection capability. To calculate a safety distance, be sure to use the increased size of the detection capability. Failure to do so causes the machine to fail to stop before an operator reaches the dangerous area and may result in serious injury. (Chapter 1-2)

Do not use the F3SN-A on machines that cannot be stopped by electrical control in case of an emergency, such as a pressing machine with full-rotation clutch system. Serious injury may result if the machine does not stop before someone reaches the hazardous part. (Chapter 2-1)

Proper configuration of the control circuit is required between the F3SN-A and the machine which it is used in PSDI "presence sensing device initiator" mode. Refer to OSHA1910.217, IEC61496-1, and other related standards and regulations for more detail on PSDI. (Chapter 2-1)

Install protective structures around the machine so that you must pass through the detection zone of the F3SN-A to reach a hazardous part of the machine. Install the F3SN-A so that some part of the operator's body remains in the detection zone at all times when the operator works in a hazardous area. (Chapter 2-1)

The switch to reset the interlock condition must be installed so that the entire hazardous area is visible and free of personnel, also the switch must not be able to be operated from within the hazardous area. (Chapter 2-1)

Do not use the F3SN-A in flammable or explosive environments. Failure to do this may cause an explosion. (Chapter 2-1)

The F3SN-A does not offer protection to the operator's body from projectiles exiting the hazardous area. Proper means of mechanical guarding must be provided to ensure protection from these potentially hazardous projectiles. (Chapter 2-1)

Always maintain the safe calculated distance between the F3SN-A and the hazardous part of a machine to avoid serious injury that may be caused by reaching the hazard before the machine has stopped. (Chapter 2-1)

Do not install the F3SN-A in a location where it can be affected by wall reflections to avoid detection failure which may result in serious injury. (Chapter 2-1)

Use the emitter and receiver in proper arrangement to avoid creation of undetectable zones. The set type of the emitter and receiver must be the same. (Chapter 2-1)

Be sure to securely fasten the F3SN-A to the machine and tighten the cable connector. (Chapter 2-1)

When using multiple sets of F3SN-A, arrange them to prevent mutual interference. (Chapter 2-1)

Do not short-circuit the outputs to the +24V. Doing so will cause the output to be always ON, creating a hazardous situation. Connect the 0V line of the power supply directly to protective earth to prevent the earth fault. Otherwise the earth fault causes the outputs to be ON. (Chapter 2-4)

Connect loads between the output and 0V line. (PNP output)

Connecting loads between the output and +24V line will reverse the operation mode and the machine will be ON when it is light-interrupted. (Chapter 2-4)



## WARNING

Always use the two OSSD outputs to configure the safety system.

Using only one OSSD of the safety system may result in serious injury when there is an output circuit failure. (Chapter 2-4)

Do not connect any of the F3SN-A lines to a DC power supply with more than 24VDC+10% or to an AC power supply to avoid the danger of electric shock. (Chapter 2-4)

DC power supply units must satisfy all of the conditions below so that the F3SN-A can comply with the applicable standards IEC 61496-1, and UL 508.

- The power supply voltage must be within specified ratings (24 VDC  $\pm$  10 %).
- The power supply is connected only to the F3SN-A and to the devices related to the electro-sensitive protective function of the F3SN-A, such as a safety controller and muting sensors, and it has enough rated current for all the devices. The power supply must not be connected to other devices or machines.
- The power supply uses double or reinforced insulation between the primary and secondary circuits
- The power supply automatically resets overcurrent protection characteristics (voltage drop).
- The power supply maintains an output holding time of at least 20 ms.
- FG (frame ground terminal) must be connected to PE (protective earth) when using a commercially available switching regulator.
- The power supply must have output characteristics of Class 2 Circuit of Limited Voltage-Current Circuit as defined in UL508 (see "2-4-1 Remark").
- The power supply must conform to regulatory requirements and standards, regarding EMC and electrical equipment safety, of the country where the F3SN-A is installed and where machinery will be operated. Example: The EMC Directive (industrial environment) and the Low Voltage Directive in EU.

A qualified person must confirm that installation, inspection and maintenance of the F3SN-A are implemented correctly as determined by local regulations where the equipment is installed and used.

Do not disassemble, repair or modify the F3SN-A.

Do not use the F3SN-A in a reflective configuration, otherwise detection may fail. (Chapter 2-1)

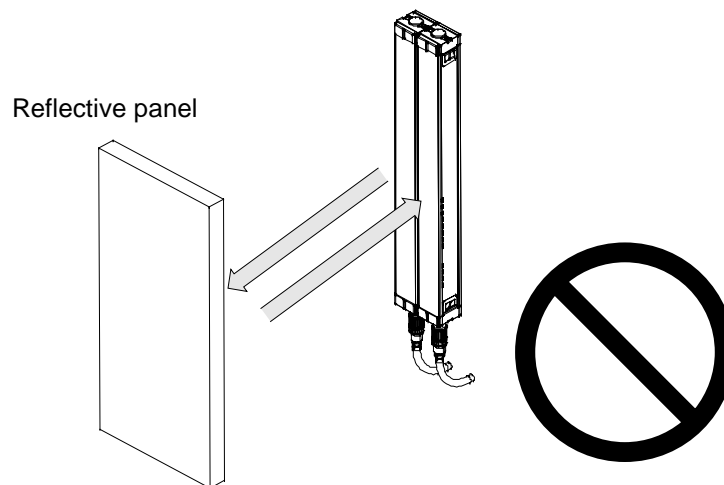

## Notice

### For your safety, always heed the followings:

- (1) The procedures of installation, inspection and maintenance in this manual should be read carefully.
- (2) Loads must satisfy all the conditions below:
  - Is not short-circuited.
  - Is not used with current higher than the rating.
- (3) All input lines and output lines of the F3SN-A should insulate against hazardous voltage levels (230 VAC, etc.), not simply against 24 VDC, with double or reinforced insulation to protect against electrical shock. In case of the combination with the F3SP-B1P, all relay output terminals (13-14, 23-24, 33-34, and 41-42) should insulate against hazardous voltage levels with basic insulation.
- (4) Be sure to dispose of the F3SN-A as industrial waste.

## Correct Usage

### For your safety, always heed the following:

#### ■ Installation Environment

- Do not install the F3SN-A in the following environments:
  - Areas exposed to intense interference light, such as direct sunlight
  - Areas with high-humidity where condensation is likely to occur
  - Areas exposed to corrosive gases
  - Areas exposed to vibration or shock levels higher than specification provisions.
  - Areas where the light curtain may come in direct contact with water.
- Do not use radio equipment, such as cellular phones, walkie-talkies, or transceivers with high power, near the F3SN-A.

#### ■ Wiring and Mounting

- Be sure to turn OFF the power prior to wiring, otherwise the diagnostic function may prevent the light curtain from operating.
- Use shielded twisted pair cable (cross-sectional area:  $\phi 0.3\text{mm}^2$  or more) when extending the communication lines with a cable other than the dedicated cable (F39-JC ), and connect the shield to the 0V line.
- When replacing the cable connector with other connectors (e.g. resin connectors), make sure the connector is rated IP54 or higher.
- When the distance between the emitter and the receiver is less than 0.2m, there is a possibility of the malfunction that the F3SN-A goes to the OFF-state momentary. Be sure to install the F3SN-A within the rated operating range.
- Check the signal name of all terminals for correct wiring.
- Devise a measure to protect against mutual interference when using two or more sets of F3SN-A beside one another.
- Do not operate the control system until one second or more after turning ON the power of the F3SN-A.
- Be sure to route the F3SN-A cable separate from high-potential power lines or through an exclusive conduit.
- The emitter and receiver are to be mounted in parallel and facing one another.

- Do not use any solvents such as paint thinners, benzine or acetone to clean the F3SN-A because it will dissolve resin and paint.

- The F3SN-A cannot detect transparent or semi-transparent materials.

## PRIOR TO USE

Verify the following items are supplied with each F3SN-A, contact your nearest OMRON representative or distributor if any item is missing.

- F3SN-A□□□□P□□ unit (emitter qty. 1, receiver qty. 1)
- Mounting brackets (top and bottom) qty. 4

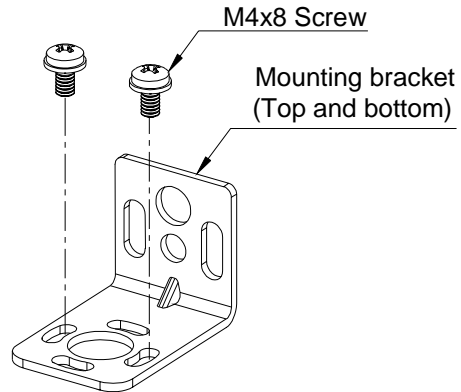

- Mounting brackets (intermediate)  
Supplied with light curtains, which have a mounting interval of 640 mm or more. A maximum of 4 sets is supplied for mounting within 640 mm (2 sets max. for each of emitter and receiver), depending on the length of the light curtain.

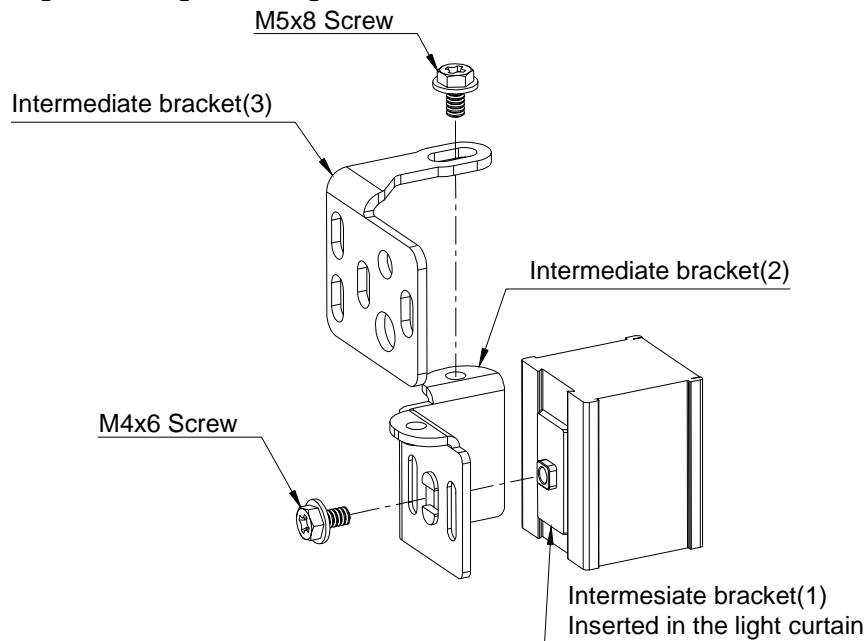

- Test Rod qty. 1  
14mm dia. for F3SN-A□□□□P14 series  
25mm dia. for F3SN-A□□□□P25 series  
40mm dia. for F3SN-A□□□□P40 series  
(Test rod is not supplied with the F3SN-A□□□□P70 series.)
- Error mode label qty. 1
- Instruction manual (this manual) qty. 1

# Contents

Section 1 Description .....	1
1-1 Features .....	1
1-2 Functions .....	2
1-2-1 Interlock function .....	2
1-2-2 Test function .....	2
1-2-3 Auxiliary Output .....	3
1-2-4 External indicator output .....	3
1-2-5 EDM (External device monitoring) .....	4
1-2-6 Fixed blanking function (Optional) .....	4
1-2-7 Floating blanking function (Optional) .....	4
1-2-8 Detection zone .....	5
1-2-9 Series connection .....	5
1-2-10 Indicators .....	6
1-3 Ratings and Performance .....	7
1-3-1 Specification .....	7
1-3-2 Response time .....	9
Section 2 Wiring and Mounting .....	10
2-1 Installation Conditions .....	10
2-1-1 Detection Zone and Intrusion Path .....	10
2-1-2 Safety Distance .....	11
2-1-3 Distances from Reflective Surfaces .....	12
2-1-4 How to Prevent Mutual Interference .....	13
2-2 Dimensional Drawings .....	15
2-2-1 Side mounting (e.g.: emitter) .....	15
2-2-2 Rear mounting (e.g.: emitter) .....	17
2-3 Mounting .....	19
2-3-1 How to Mount the Unit .....	19
2-3-2 Dimensional Drawing of the Mounting Bracket .....	20
2-4 Wiring .....	22
2-4-1 Power Supply Units .....	22
2-4-2 Wiring Diagram .....	23
2-4-3 Wiring Procedures .....	25
2-4-4 Adjustment Procedures .....	26
2-5 Check List .....	27
Section 3 I/O Circuit .....	29
Section 4 Application .....	31
Section 5 Maintenance .....	33
5-1 Daily Inspections .....	33
5-2 Inspections Every Six Months .....	34
Section 6 Troubleshooting .....	35
6-1 Lockout condition .....	35
6-2 Other trouble .....	36
Section 7 Optional Accessory .....	37
Section 8 Referenced standards .....	39

# Section 1 Description

## 1-1 Features

### Available in either 7 m or 10 m operating range:

- F3SN-A□□□□P14 Series: 7 m
- F3SN-A□□□□P25 Series: 10 m
- F3SN-A□□□□P40 Series: 10 m
- F3SN-A□□□□P70 Series: 10 m

### Detection capability:

- F3SN-A□□□□P14 Series: 14 mm dia.
- F3SN-A□□□□P25 Series: 25 mm dia.
- F3SN-A□□□□P40 Series: 40 mm dia.
- F3SN-A□□□□P70 Series: 70 mm dia.

### Protective height (light curtain length): Come in wide selection to suit individual requirements

- F3SN-A□□□□P14 Series: 106 models in 9 mm increments between 180 mm ~ 1125 mm
- F3SN-A□□□□P25 Series: 108 models in 15 mm increments between 217 mm ~ 1822 mm
- F3SN-A□□□□P40 Series: 54 models in 30 mm increments between 217 mm ~ 1807 mm
- F3SN-A□□□□P70 Series: 27 models in 60 mm increments between 277 mm ~ 1777 mm

**[Note]:** The following types are available on request. For ordering, consult our sales staff:

F3SN-A□□□□P14 Series (except for the F3SN-A□□□□P14 which number of beams is odd number.), F3SN-A□□□□P25-02, F3SN-A□□□□P40 Series, F3SN-A□□□□P70 Series

### External size of the light curtain ≅ Protective height:

(Except for the F3SN-A□□□□P14 series)

### Indication of light intensity

Received light intensity is indicated by a 5-bar LED display to aid in beam alignment.

### Indication of error mode

Error mode is indicated by a separate 3-bar LED display.

### Safety-related functions:

- External test function (Emission stop function)
- EDM (External device monitoring function)
- Interlock function
- Fixed blanking function / Floating blanking function (require set by the F39-MC11)

### Auxiliary output (Non-safety output)

Allows the light curtain status to be transmitted to a PLC or other device.

### Control Unit: F3SP-B1P (Optional accessory)

Allows for quick connection of the light curtain into the safety circuit.

### Setting Console: F39-MC11 (Optional accessory)

By connecting this handheld console to the light curtain, various functions of the light curtain can be accessed.

### Degree of protection : IP65 (for light curtain only)

### Series connectable models

The series-connection type allows multiple units to be connected together to protect against mutual interference, or an external indicator can be connected to indicate the light curtain status.

### [Nomenclature]

F3SN – A□□□□P□□ – □ – □□

① ② ③ ④ ⑤

① Protective height (mm)

② P: PNP output type

③ Detection capability (mm)

④ Blank: Set of emitter and receiver, L: Emitter, D: Receiver

⑤ Connection method

	Connection with main system	Series connection
Blank	Connector type	-
01	Connector type	Connector type
02	Cable with connector	-



## Section 1 Description

### 1-2 Functions

#### 1-2-1 Interlock function

The auto reset mode and the manual reset mode are wire selectable features of the F3SN-A.

##### 1) Auto reset mode

After the power is turned ON and none of the beams are interrupted the OSSD (Output Signal Switching Device) outputs will go to their ON-state.

To enable auto reset mode:

- ① Leave the interlock selection input line open or connect it to 0VDC.
- ② Connect the Reset input line to 24VDC. (9VDC to  $V_s$ , nominal 24VDC)
- ③ Turn ON the power to the F3SN-A.

##### 2) Manual reset mode

There are 3 options for manual reset:

- Start/restart interlock  
After the power is turned ON, or when at least one beam is interrupted, the light curtain enters the interlock condition.
- Start interlock  
Only after power ON, the light curtain enters the interlock condition.
- Restart interlock  
Only when at least one beam is interrupted, the light curtain enters the interlock condition.

For the factory setting, the start/restart interlock is selected in the manual reset mode. Other options are selected by the setting console, F39-MC11 (optional). When the light curtain enters the interlock condition, it keeps the OSSD outputs in the OFF-state. Even if all beams become free, the OSSD outputs will not go to the ON-state. When none of the beams are interrupted in the detection zone, applying the reset input<sup>(\*)</sup> resets the interlock condition and the OSSD outputs go to the ON-state.

- \*1. Apply a voltage of 24VDC (9VDC to  $V_s$ , nominal 24VDC) to the reset input line for 100 ms or more, then remove power to the reset input line or apply a voltage of 0 VDC.

To enable manual reset mode:

- ① Connect the Interlock selection input line to 24VDC (9VDC to  $V_s$ , nominal 24VDC)
- ② Connect the reset input line to 24VDC (9VDC to  $V_s$ , nominal 24VDC) via a reset switch (normally open contact).
- ③ Turn on the power to the light curtain while the reset switch contact remains open.

**[Note1]:** The switch to reset the interlock condition has to be installed out of the hazardous area. Before the start/restart interlock is reset, the hazardous area must be visibly free of personnel.

**[Note2]:** Prevent short-circuiting of unconnected wires of the light curtain with other wires.

#### 1-2-2 Test function

##### 1) Self-test

After power ON, the F3SN-A performs a complete self-test within 1 second. In addition, it performs a self-test (within response time) periodically during operation.

##### 2) External test

This function will stop the light-emitting of the light curtain at any time to confirm the output is turned OFF normally. Applying a voltage of 24VDC (9V to  $V_s$ , nominal 24VDC)<sup>(NOTE1)</sup> to the test input line of the emitter makes the emitter stop emitting.

**[Note1]:** Applied time should be more than four times of  $T_{OFF}$ .

**[Note2]:** For  $T_{ON}$  and  $T_{OFF}$ , refer to "1-3 Ratings and Performance."

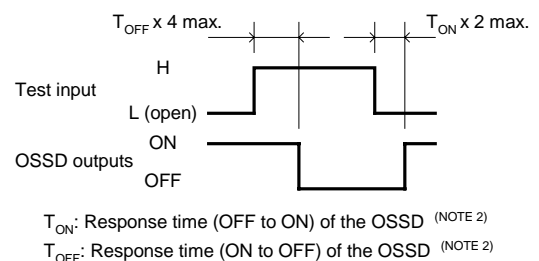

### 3) Error detection and restoration (Lockout condition)

If an error is detected by the self-test the light curtain enters the lockout condition, keeps the OSSD outputs in their OFF-state and displays the error mode<sup>(\*)</sup>.

Turning the power ON again, or applying the reset input<sup>(\*\*)</sup> to the light curtain, resets the lockout condition (For noise, eliminating the noise automatically resets the lockout condition.)

\*1. Refer to "1-2-10 Indicators" for the indicating patterns.

\*2. In case of manual reset mode: Apply a voltage of 24VDC (9VDC to  $V_s$ , nominal 24VDC) to the reset input line for 100 ms or more, then remove power to the reset input line or apply a voltage of 0VDC.

In case of auto reset mode: Open the reset input line or connect it to 0VDC for 100ms or more, then re-apply a voltage of 24VDC (9VDC to  $V_s$ , nominal 24VDC).

### 1-2-3 Auxiliary Output (Non-safety output)

The default of this output is the reverse signal of the safety outputs (Dark-ON output). This output can be used for monitoring purposes by connecting it to a device such as a PLC.

The auxiliary output can be selected to give one of the following output operation modes by the F39-MC11.

- Dark-ON output mode
- Light-ON output mode
- Light diagnosis mode
- Lockout mode
- Outermost-beam monitoring mode
- Specified-beam mode
- Blanking monitoring mode

The diagram on the right shows the timing chart for the Dark-ON output mode. For detailed information, refer to the instruction manual of the F39-MC11.

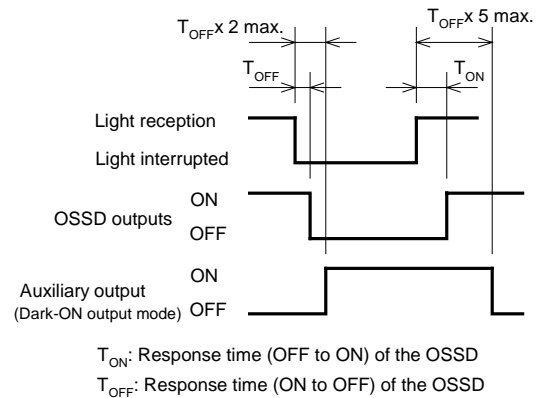

### 1-2-4 External indicator output (Non-safety output, available for the series-connection type only)

This output can be connected to an external indicator to display one of the operation modes as selected by the F39-MC11. The default of this output is Light-ON output. Selectable output modes are as follows.

- Dark-ON output mode
- Light-ON output mode
- Light diagnosis mode
- Lockout mode

The diagram on the right shows the timing chart for the Light-ON output mode. For detailed information, refer to the instruction manual for the F39-MC11.

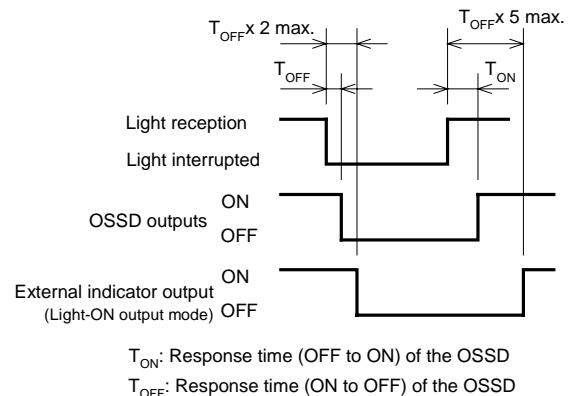

The large indicator can be directly attached to the light curtain by using the external indicator F39-A01P□-□(optional), as shown in the figure on the right, for use with series-connection types only.

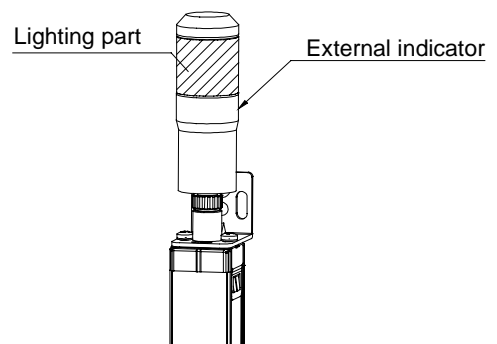

## Section 1 Description

### 1-2-5 EDM (External device monitoring)

This function makes it possible to monitor the state of the NC contacts of the MPCEs<sup>(\*)</sup>, so that a malfunction of a MPCE, such as a welded contact, can be detected. Connect<sup>(\*\*)</sup> the NC contact of the MPCEs to the EDM input line of the receiver. If the correct logical relationship between the OSSD outputs and the EDM input is not kept, the light curtain immediately enters the lockout condition and the OSSD outputs will go to their OFF-state. The light curtain's normal operation is up to 300ms max.<sup>(\*\*\*)</sup>, this allows for the delay time caused by the release of the MPCEs. To ensure the correct usage of this function, the MPCEs must be safety-approved types with forcibly-guided contacts.

#### [When the EDM is not used]

In the case the EDM input is not used, connect the auxiliary output in the Dark-ON output mode to the EDM input line, or disable the EDM with the F39-MC11 setting console.

- \*1. MPCEs (Machine Primary Control Elements) are usually relays or contactors used to control hazardous movement directly.
- \*2. Connect the wires such that 24VDC (9VDC to Vs, nominal 24VDC) is applied to the EDM input via the series connected NC contacts (Refer to 2-4 Wiring).
- \*3. The value can be changed by the F39-MC11.

### 1-2-6 Fixed blanking function (Optional)



#### WARNING

After setting the fixed blanking, check that the F3SN-A detects a test rod at any position in the detection zone through which a person can reach the hazardous part of the machine. If any positions are found by check above, install protective structures to prevent intrusion, which the F3SN-A can not detect. Failure to do so may result in serious injury.

This function is set with the F39-MC11 setting console and disables part of detection zone of the light curtain. If an object enters the disabled detection zone, the OSSD outputs status will not change. This function is used when there is a stationary object in the detection zone that needs to be ignored.

Refer to the instruction manual of the F39-MC11 for detailed information.

### 1-2-7 Floating blanking function (Optional)



#### WARNING

Use of the floating blanking increases the size of the detection capability. To calculate a safety distance, be sure to use the increased size of the detection capability. Failure to do so causes the machine to fail to stop before an operator reaches the dangerous area and may result in serious injury.

This function is set with the F39-MC11 setting console.

During normal operation when floating blanking is disabled, and at least one beam is interrupted the light curtain will go to the OFF-state. However, using this function prevents the light curtain from going to the OFF-state until multiple beams<sup>(\*)</sup> are interrupted.

- \*1. The number of the floating blanking beams can be selected in the range of 1 to 3 beams.
- \*2. This function can be set so that the light curtain goes to the OFF-state only if the interrupted beams are adjacent to each other and the number of interrupted beams is the set number or more.
- \*3. This function can be set so that the top and bottom beams cannot be set for the function.

The size of the detection capability is increased by using floating blanking as shown in the following table. The label on the light curtain indicates all 4 kinds of the possible detection capabilities. Obscure inapplicable sizes of the detection capability with a permanent marker, and leave only an applicable size on the label.

	No. of floating blanking beams			
	No beam	1 beam	2 beams	3 beams
F3SN-A□□□□P14 series	14 mm	23 mm	32 mm	41 mm
F3SN-A□□□□P25 series	25 mm	40 mm	55 mm	70 mm
F3SN-A□□□□P40 series	40 mm	70 mm	100 mm	130 mm
F3SN-A□□□□P70 series	70 mm	130 mm	190 mm	250 mm

For detailed information, refer to the instruction manual for F39-MC11.

## 1-2-8 Detection zone

### [Protective height]

F3SN-A□□□□P14 series : Protective height = Total length of the optical cover  
 Other series : Protective height = Total length of the light curtain

### [Beam centre-line mark]

The two lines marked at the centre of the cap indicate the centre of the beam (See the figure shown below). This position is a reference line for measuring safety distance. Use the line closer to the hazardous area as a reference line for the safety distance.

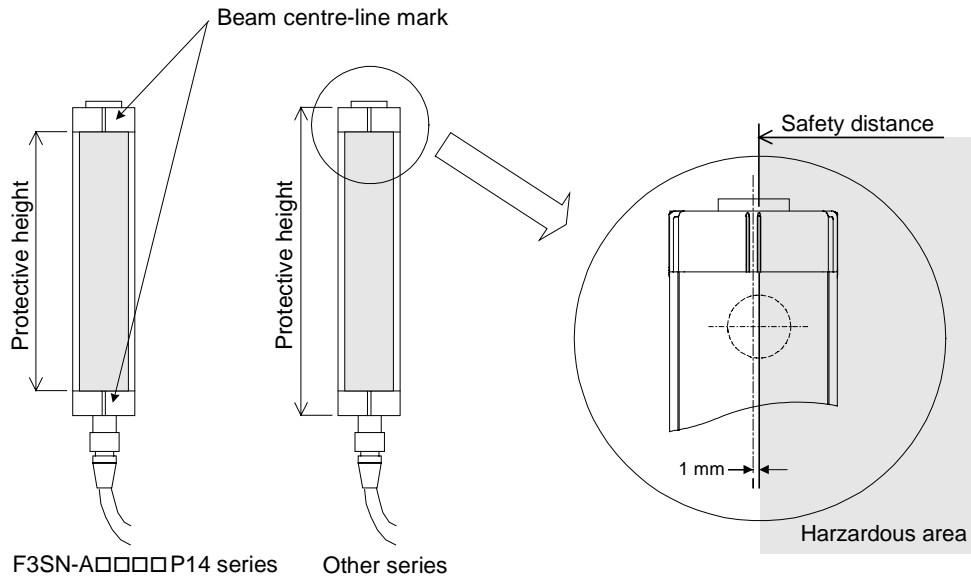

## 1-2-9 Series connection

Light curtains can be connected in series using the types supplied with the connector for the series connection as shown in the figure below. Both the stand-alone type and the series connection type can be used for the light curtains located at the top end. (The F3SN-A□□□□P□□ series can connect with the F3SN-A□□□□P□□ series only.)

When any beam of the light curtains connected in series is interrupted, both the OSSD outputs go to the OFF-state. The LED indicators for each light curtain are individually lit.

- No. of series connected light curtains: Up to 3 sets
- No. of beams: Up to 240 beams
- Length of the series connection cable: 3 m max.

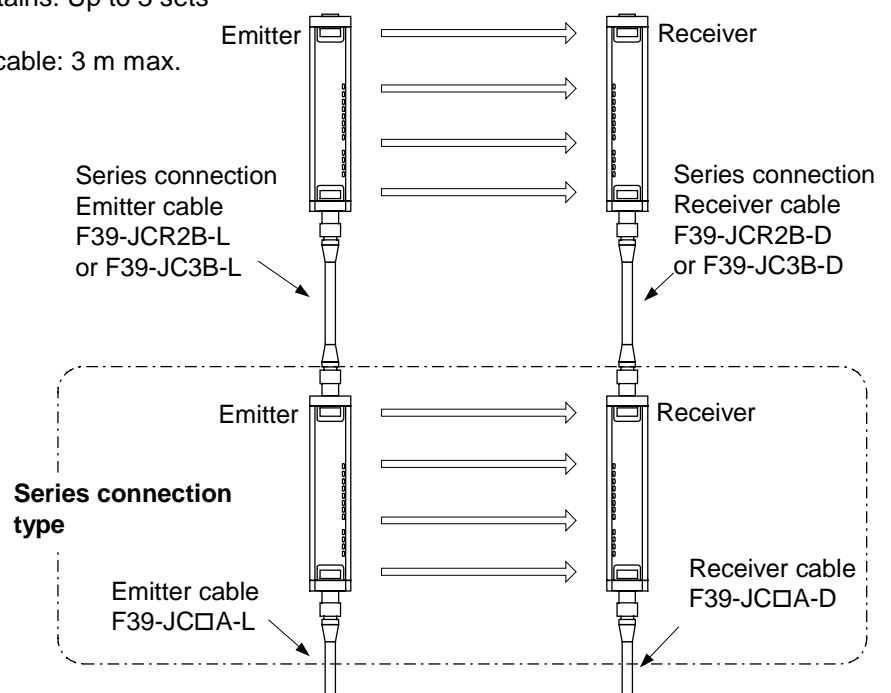

# Section 1 Description

## 1-2-10 Indicators

[Emitter]

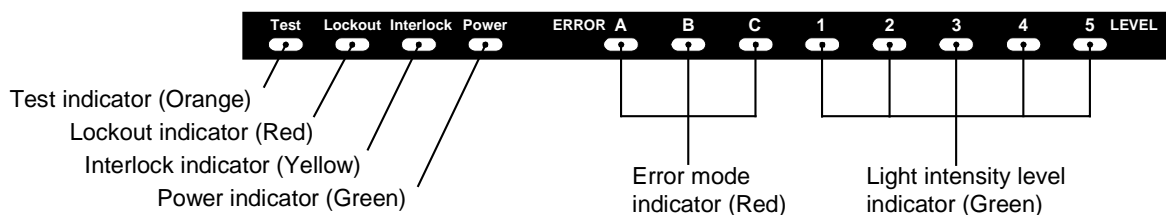

[Receiver]

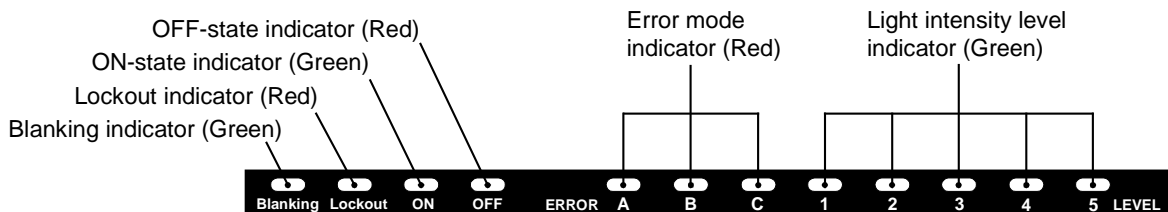

- Power indicator : Lit when power is supplied
- Interlock indicator : Lit during interlock condition
- Lockout indicator : Flashing during lockout condition
- Test indicator : Lit during external test, Flashing after a lapse of 30000 hours
- ON-state indicator : Lit when OSSD outputs are in ON-state
- OFF-state indicator : Lit when OSSD outputs are in OFF-state
- Blanking indicator : Lit when blanking is set, flashing when the F39-MC11 is connected, Flashing after a lapse of 30000 hours
- Light intensity level indicator : Lit according to light intensity (See the table shown below)
- Error mode indicator : Flashing to indicate error mode (Flashing pattern varies depending on the error condition. See the table shown below)

	1	2	3	4	5	Light intensity level
<b>Light intensity level indicator</b>  Lit     Not lit						200% and above of ON threshold level
						150 to 200% of ON threshold level
						100 to 150% of ON threshold level
						75 to 100% of ON threshold level
						50 to 75% of ON threshold level
						less than 50% of ON threshold level

	A	B	C	Cause of error
<b>Error mode indicator</b>  Flashing     Not lit				The Interlock selection input line or the reset input line is not wired correctly or became open.
				Relay contact is welded. Releasing time of the relay takes too long. The EDM input line is not wired correctly or became open.
				Communication line (RS-485) is not wired correctly, became open, or causes other errors.
				One of the OSSD outputs is shorted or is not wired correctly.
				Mutual interference. Interference light is received.
				Types of the receiver and emitter are not the same. Numbers of the receiver and emitter connected in series are not the same.
				External noise. Internal hardware failure of the receiver or the emitter.

\* Attaching the supplied error mode label near the light curtain facilitates diagnosis of the cause of errors.

## 1-3 Ratings and Performance

### 1-3-1 Specification

The 4-digit numbers indicating the protective heights are substituted by □□□□ in the type names.

Type	Stand-alone	F3SN-A□□□□P14 F3SN-A□□□□P14-02	F3SN-A□□□□P25 F3SN-A□□□□P25-02	F3SN-A□□□□P40 F3SN-A□□□□P40-02	F3SN-A□□□□P70 F3SN-A□□□□P70-02
	Series connection	F3SN-A□□□□P14-01	F3SN-A□□□□P25-01	F3SN-A□□□□P40-01	F3SN-A□□□□P70-01
Detection capability		Non-transparent: 14 mm min. in diameter	Non-transparent: 25 mm min. in diameter	Non-transparent: 40 mm min. in diameter	Non-transparent: 70 mm min. in diameter
Beam gap (P)		9 mm	15 mm	30mm	60mm
No. of beams (n)		20 to 125	13 to 120	7 to 60	5 to 30
Protective height(PH)		180 to 1125 mm	217 to 1822 mm	217 to 1807 mm	277 to 1777 mm
		PH = n x P	PH = (n-1) x P + 37		
Operating range		0.2 to 7.0 m	0.2 to 10.0 m		
Response time		ON to OFF: 10ms to 15.5ms max. OFF to ON: 40ms to 62ms max. (under stable light incident condition), See 1-3-2 for detail.			
Startup waiting time		1 s max.			
Supply voltage (Vs)		24 VDC ±10% (ripple p-p 10% max.)			
Current consumption (under no-load conditions)	Emitter	Up to 50 beams:140 mA max., 51 to 85 beams:155 mA max., 86 beams and more:170 mA max.			
	Receiver	Up to 50 beams:100 mA max., 51 to 85 beams:110 mA max., 86 beams and more:120 mA max.			
Light source		Infrared LED (870 nm wavelength)			
Effective aperture angle (EAA)		Within ±2.5° for the emitter and receiver at a detection distance of at least 3 m according to IEC 61496-2			
OSSD *1		Two PNP transistor outputs, load current 300 mA max., residual voltage 2 V max. (except for voltage drop due to cable extension)			
Auxiliary output (Non-safety output)		One PNP transistor output, load current 50 mA max., residual voltage 2 V max. (except for voltage drop due to cable extension)			
External indicator output (Non-safety output) *2		One PNP transistor output, load current 50 mA max., residual voltage 2 V max. (except for voltage drop due to cable extension)			
Output operation mode *1		OSSD output : Light-ON Auxiliary output : Dark-ON (can be changed by the F39-MC11) External indicator output : Light-ON (can be changed by the F39-MC11) *2			
Input voltage		Test input, Interlock selection input, Reset input, EDM input: ON voltage : 9 to 24 VDC (3 mA max. sink current) OFF voltage : 0 to 1.5 VDC or open			
Indicators	Emitter	Light intensity level indicator (Green LED x5) : Lit according to light intensity Error mode indicator (Red LED x3) : Flashing to indicate error mode Power indicator (Green LED) : Lit when power is supplied Interlock indicator (Yellow LED) : Lit during interlock condition Lockout indicator (Red LED) : Flashing during lockout condition Test indicator (Orange LED) : Lit during external test *3			
	Receiver	Light intensity level indicator (Green LED x5) : Lit according to light intensity Error mode indicator (Red LED x3) : Flashing to indicate error mode OFF-state indicator (Red LED) : Lit when OSSDs are in OFF-state ON-state indicator (Green LED) : Lit when OSSDs are in ON-state Lockout indicator (Red LED) : Flashing during lockout condition Blanking indicator (Green LED) : Lit when blanking is set *3			
Mutual interference prevention function *2		<ul style="list-style-type: none"> <li>• Number of series connected light curtains: Up to 3 sets</li> <li>• Number of beams: Up to 240 beams</li> <li>• Length of the series connection cable: 3 m max.</li> </ul>			
Test functions		<ul style="list-style-type: none"> <li>• Self-test (After power ON, and during operation)</li> <li>• External test (Light emission stop function by test input)</li> </ul>			



### 1-3-2 Response time

The response time of OSSD outputs are as follows:

F3SN-A□□□□P14 series	Protective height(mm)	No. of beams	Response time (ON to OFF)	Response time (OFF to ON)
	180 to 450	20 to 50	10.0	40
	459 to 765	51 to 85	12.5	50
	774 to 1080	86 to 120	15.0	60
	1089 to 1125	121 to 125	15.5	62

F3SN-A□□□□P25 series	Protective height(mm)	No. of beams	Response time (ON to OFF)	Response time (OFF to ON)
	217 to 772	13 to 50	10.0	40
	787 to 1297	51 to 85	12.5	50
	1312 to 1822	86 to 120	15.0	60

F3SN-A□□□□P40 series	Protective height(mm)	No. of beams	Response time (ON to OFF)	Response time (OFF to ON)
	217 to 757	7 to 25	10.0	40
	787 to 1297	26 to 43	12.5	50
	1327 to 1807	44 to 60	15.0	60

F3SN-A□□□□P70 series	Protective height(mm)	No. of beams	Response time (ON to OFF)	Response time (OFF to ON)
	277 to 757	5 to 13	10.0	40
	817 to 1297	14 to 22	12.5	50
	1357 to 1777	23 to 30	15.0	60

- **Response time for series connected types is calculated as follows:**

**For 2 sets:**

Response time (ON to OFF): Response time of Light curtain 1 + Response time of Light curtain 2 + 3 ms  
 Response time (OFF to ON): Response time of Light curtain 1 + Response time of Light curtain 2 + 12 ms

**For 3 sets:**

Response time (ON to OFF): Response time of Light curtain 1 + Response time of Light curtain 2  
 + Response time of Light curtain 3 + 4 ms  
 Response time (OFF to ON): Response time of Light curtain 1 + Response time of Light curtain 2  
 + Response time of Light curtain 3 + 16 ms

- **Response time of F3SP-B1P is 10 ms, operation time is 100 ms.**

**[Note]:** If the controller is included in the set, calculate safety distance by adding the controller response time to the F3SN response time.



## Section 2 Wiring and Mounting

# Section 2 Wiring and Mounting

## 2-1 Installation Conditions

### 2-1-1 Detection Zone and Intrusion Path

#### **WARNING**

Do not use the F3SN-A on machines that cannot be stopped by electrical control in case of an emergency, such as a pressing machine with full-rotation clutch system. Serious injury may result if the machine does not stop before someone reaches the hazardous part.

Proper configuration of the control circuit is required between the F3SN-A and the machine which it is used in PSDI "presence sensing device initiator" mode. Refer to OSHA1910.217, IEC61496-1, and other related standards and regulations for more detail on PSDI.

Install protective structures around the machine so that you must pass through the detection zone of the F3SN-A to reach a hazardous part of the machine. Install the F3SN-A so that some part of the operator's body remains in the detection zone at all times when the operator works in a hazardous area.

The switch to reset the interlock condition must be installed so that the entire hazardous area is visible and free of personnel, also the switch must not be able to be operated from within the hazardous area

Do not use the F3SN-A in flammable or explosive environments. Failure to do this may cause an explosion.

The F3SN-A does not offer protection to the operator's body from projectiles exiting the hazardous area. Proper means of mechanical guarding must be provided to ensure protection from these potentially hazardous projectiles.

Be sure to securely fasten the F3SN-A to the machine and tighten the cable connector.

#### Correct Installation

A hazardous part of a machine can be reached only by passing through the sensor detection zone.

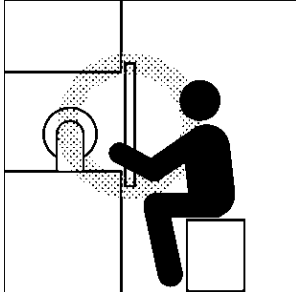

Some part of the operator's body remains in the detection zone while they are working.

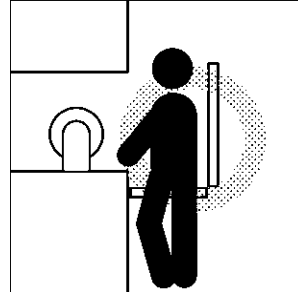

#### Incorrect Installation

A hazardous part of a machine can be reached without passing through the sensor detection zone.

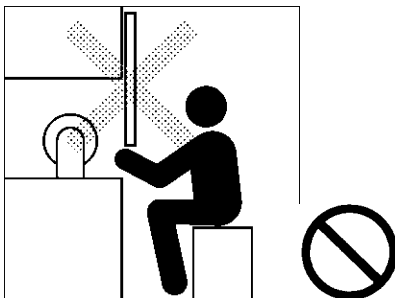

A worker is between the sensor detection zone and a hazardous part of a machine.

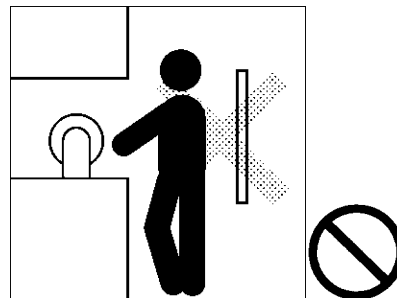

### 2-1-2 Safety Distance



#### WARNING

Always maintain a safe distance (S) between the F3SN-A and a hazardous part of a machine.  
 Serious injury may result if the machine does not stop before someone reaches the hazardous part.

The "Safety distance" is the minimum distance that must be maintained between the F3SN-A and a hazardous part of a machine in order to stop the machine before someone or something reaches it. The safety distance is calculated based on the following equation when a person moves perpendicular to the detection zone of a light curtain.

Safety distance (S) = Intrusion speed into the detection zone (K) x Total response time for the machine and light curtain (T) + Additional distance calculated based on the detection capability of the light curtain (C) ... (1)

The safety distance varies with national standards and individual machine standards. Be sure to refer to related standards.

The equation is also different if the direction of intrusion is not perpendicular to the detection zone of the light curtain.

#### <Reference> Method for calculating safety distance as provided by European Norm EN999 (for intrusion perpendicular to the detection zone)

##### [Detection capability: 40mm or less]

Substitute  $K = 2,000 \text{ mm/s}$  and  $C = 8 (d - 14 \text{ mm})$  in equation (1) and calculate as shown below.

$$S = 2,000 \text{ mm/s} \times (T_m + T_s) + 8 (d - 14 \text{ mm}) \quad \dots(2)$$

Where: S = Safety distance (mm)

$T_m$  = Machine response time (s) \*1

$T_s$  = Light curtain response time (s) \*2

d = Detection capability of the light curtain (mm)

e.g.:

$$T_m = 0.05\text{s}, T_s = 0.01\text{s}, d = 14 \text{ mm}:$$

$$S = 2,000 \text{ mm/s} \times (0.05\text{s} + 0.01\text{s}) + 8 (14 \text{ mm} - 14 \text{ mm}) \\ = 120 \text{ mm}$$

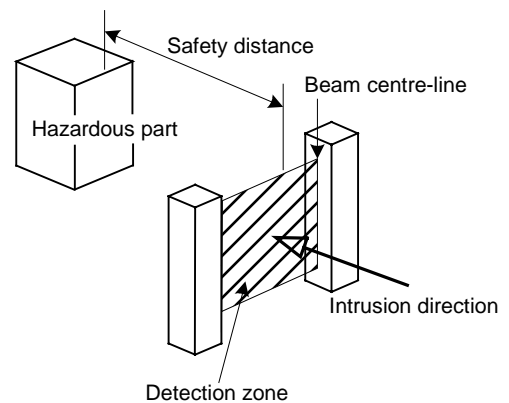

Use  $S = 100 \text{ mm}$  if the result of equation (2) is less than 100 mm.

Recalculate using the following equation with  $K = 1,600 \text{ mm/s}$  if the result is over 500 mm.

$$S = 1,600 \text{ mm/s} \times (T_m + T_s) + 850 \quad \dots(3)$$

Use  $S = 500 \text{ mm}$  if the result from equation (3) is less than 500 mm.

##### [Detection capability: over 40mm]

Substitute  $K = 1,600 \text{ mm/s}$  and  $C = 850 \text{ mm}$  in equation (1) and calculate as shown below.

$$S = 1,600 \text{ mm/s} \times (T_m + T_s) + 850 \quad \dots(4)$$

Where :S = Safety distance (mm)

$T_m$  = Machine response time (s) \*1

$T_s$  = Light curtain response time (s) \*2

e.g.:

$$T_m = 0.05\text{s}, T_s = 0.01\text{s}:$$

$$S = 1,600 \text{ mm/s} \times (0.05\text{s} + 0.01\text{s}) + 850 \text{ mm} \\ = 946 \text{ mm}$$

- \*1. The machine response time refers to the maximum time from the moment the machine receives a stop signal to the moment the hazardous part of the machine stops. The machine response time should be measured on actual machines. The machine response time should be measured and confirmed periodically.
- \*2. The light curtain response time refers to the time required for output to change from ON to OFF.

## Section 2 Wiring and Mounting

### <Reference> Method for calculating the safety distance as provided by ANSI B11.19 (US)

Safety distance (S) = Intrusion speed into the detection zone (K) x Response time (Ts + Tc + Tr + Tbm) + Additional distance (Dpf) ... (5)

Where: K = Intrusion speed (Recommended value in OSHA standards is 1,600 mm/s)

ANSI B11.19. does not define Intrusion speed (K). When determining K, consider possible factors including physical ability of operators.

Ts = Time required for machine to stop (s)

Tr = F3SN-A response time (s) \*1

Tc = Maximum response time required for machine control circuit to apply brake (s)

Tbm = Additional time (s)

If the machine is provided with a brake monitor, Tbm = brake monitor setting time - (Ts + Tc). If not provided with a brake monitor, it is recommended to determine a value more than 20% of (Ts + Tc) as the additional time.

Dpf = Additional distance. Dpf is calculated as follows based on ANSI standards.

Dpf = 3.4 x (d - 7.0): d is the detection capability of the light curtain (mm).

e.g.:

Where: K = 1,600 mm/s, Ts + Tc = 0.06s, Brake monitor setting time = 0.1s, Tr = 0.1s, d = 14mm,

From equation (5):

Tbm = 0.1 - 0.06 = 0.04s

Dpf = 3.4 x (14 - 7.0) = 23.8mm

S = 1,600 x (0.06 + 0.1 - 0.04) + 23.8 = 215.8mm

\*1. The light curtain response time refers to the time required for output to change from ON to OFF.

### 2-1-3 Distances from Reflective Surfaces



**WARNING**

Be sure to install the F3SN-A to minimize the effects of reflection from nearby surfaces. Failure to do so may cause detection to fail and may result in serious injury.

Install the F3SN-A with minimum Distance D shown below from reflective surfaces (highly reflective surfaces) such as metal walls, floors, ceilings, and work pieces.

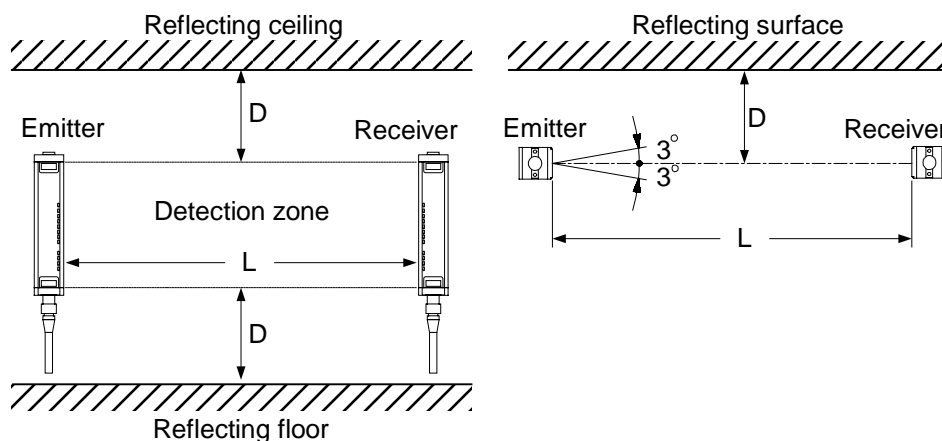

Distance between emitter and receiver (Operating range L)	Minimum installation distance D
0.2 to 3m	0.16m
over 3m	$L \times \tan 3^\circ = L \times 0.052$ (m)

[Note]: Effective aperture angle of the F3SN-A is  $\pm 2.5^\circ$  (when  $L > 3m$ ) as defined by IEC61496-2. However, set the effective aperture angle to  $\pm 3^\circ$  and install the F3SN-A apart from reflective surfaces with considering differences of the beams during installation.

### 2-1-4 How to Prevent Mutual Interference



#### WARNING

The set type of the emitter and receiver must be the same.

Do not use the F3SN-A in a reflective configuration. Otherwise detection may fail.

When using multiple sets of F3SN-A, connect them and/or use light interruption panels to prevent mutual interference.

#### 1) Series connection (Up to 3 sets, 240 beams, the series connection type is required for connection)

Multiple sets of the F3SN-A can be connected in series.

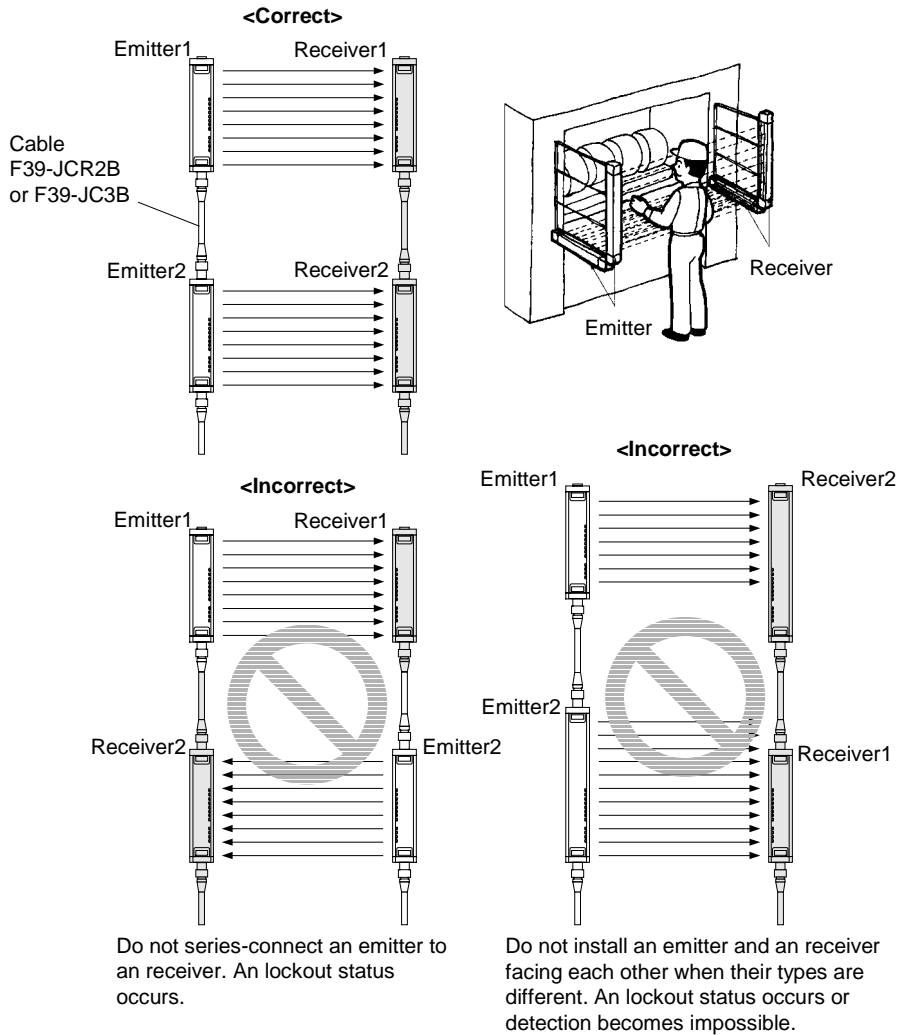

## Section 2 Wiring and Mounting

### 2) When not connected

When installing two or more light curtains without connecting them to each other due to wiring conditions, considerations must be made to prevent mutual interference. Failure to do so may cause the F3SN-A to go into a lockout condition.

#### Installation which may cause mutual interference

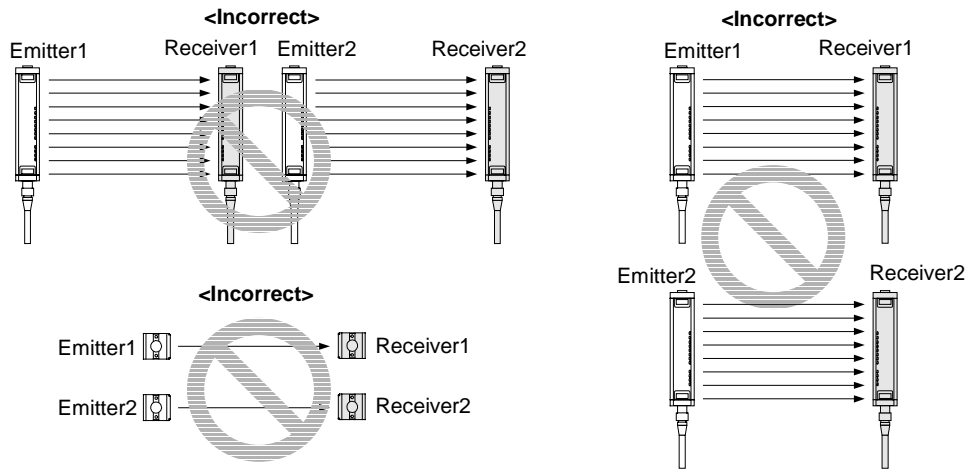

#### Installation to prevent mutual interference

- Install so that the two light curtains emit in the opposite directions (staggered).

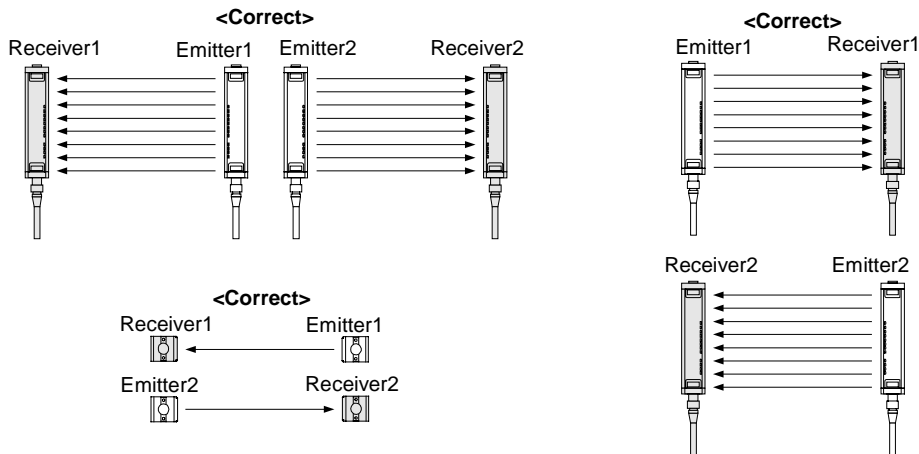

- Install a light interrupting wall in between sensors.

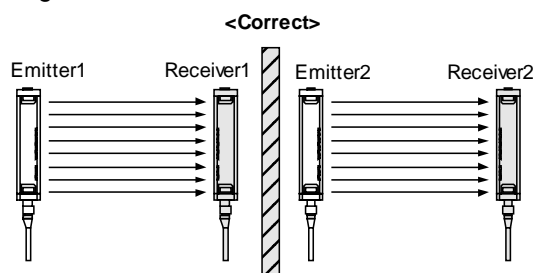

- Install the light curtains facing away from the one another to eliminate mutual interference.

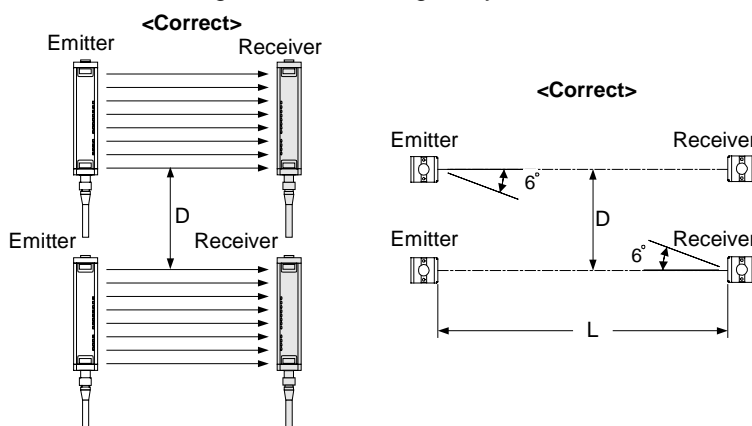

Distance between emitter and receiver (Operating range L)	Minimum installation distance D
0.2 to 3m	0.32m
over 3m	$L \times \tan 6^\circ = L \times 0.105 \text{ (m)}$

## 2-2 Dimensional Drawings

### 2-2-1 Side mounting (e.g.: emitter)

● F3SN-A□□□□P□□

Dimensions according to the type can be calculated by using the following equations.

**F3SN-A□□□□P14 series**

Dimension C2 (Protective height): 4 digits in the type name

Dimension A = C2 + 86

Dimension B = C2 + 54

Dimension D = 15.5

Dimension E = C2 – 9

Dimension F: See the right table.

Protective height (C2)	Number of intermediate mounting bracket	Dimension F (*1)
to 0620	0	–
0621 to 1125	1	F = B / 2

**Other series**

Dimension C1 (Protective height) : 4 digits in the type name

Dimension A = C1 + 64

Dimension B = C1 + 32

Dimension D = 18.5

Dimension E = C1 – 37

Dimension F: See the right table.

Protective height (C1)	Number of intermediate mounting bracket	Dimension F (*1)
to 0640	0	–
0641 to 1280	1	F = B / 2
1281 to 1822	2	F = B / 3

\*1. If value F obtained from the above equation is not used, set F to 670 mm or less.

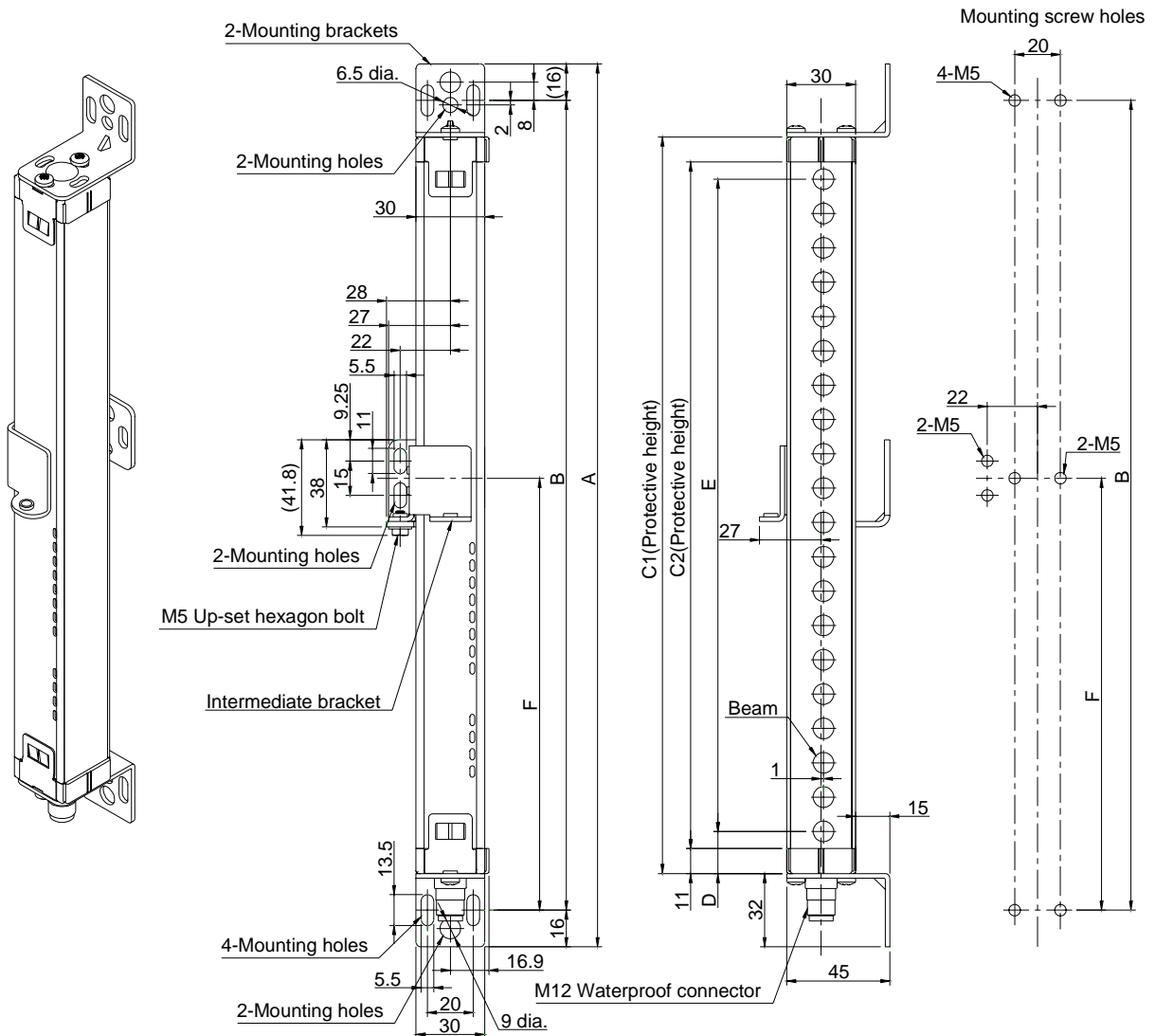

## Section 2 Wiring and Mounting

The following figures show only dimensions which are different from those of the F3SN-A□□□□P□□

### ● F3SN-A□□□□P□□-01

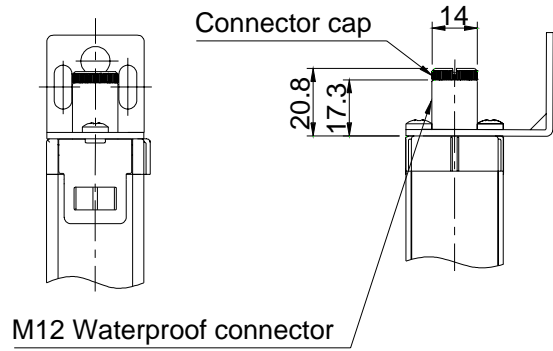
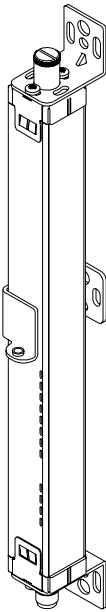

### ● F3SN-A□□□□P□□-02

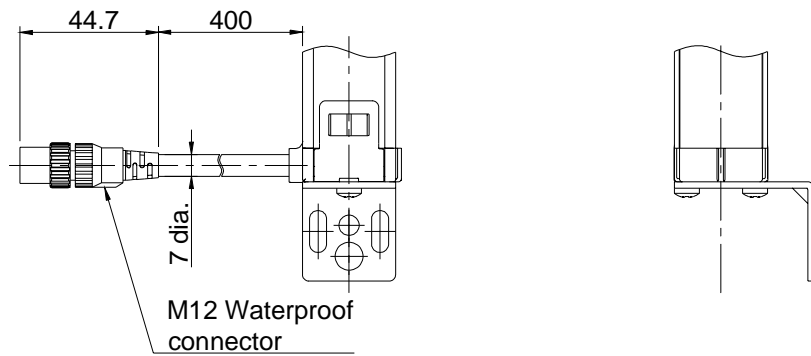
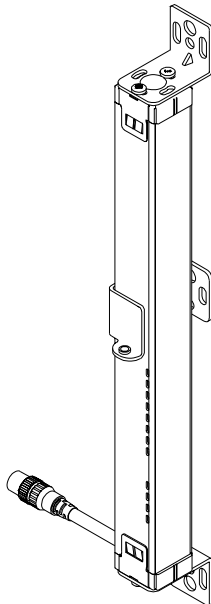

## 2-2-2 Rear mounting (e.g.: emitter)

● F3SN-A□□□□P□□

Dimensions according to the type can be calculated by using the following equations.

**F3SN-A□□□□P14 series**

Dimension C2 (Protective height): 4 digits in the type name

Dimension A = C2 + 86

Dimension B = C2 + 54

Dimension D = 15.5

Dimension E = C2 - 9

Dimension F: See the right table.

Protective height (C2)	Number of intermediate mounting bracket	Dimension F (*1)
to 0620	0	-
0621 to 1125	1	F = B / 2

**Other series**

Dimension C1 (Protective height) : 4 digits in the type name

Dimension A = C1 + 64

Dimension B = C1 + 32

Dimension D = 18.5

Dimension E = C1 - 37

Dimension F: See the right table.

Protective height (C1)	Number of intermediate mounting bracket	Dimension F (*1)
to 0640	0	-
0641 to 1280	1	F = B / 2
1281 to 1822	2	F = B / 3

\*1. If value F obtained from the above equation is not used, set F to 670 mm or less.

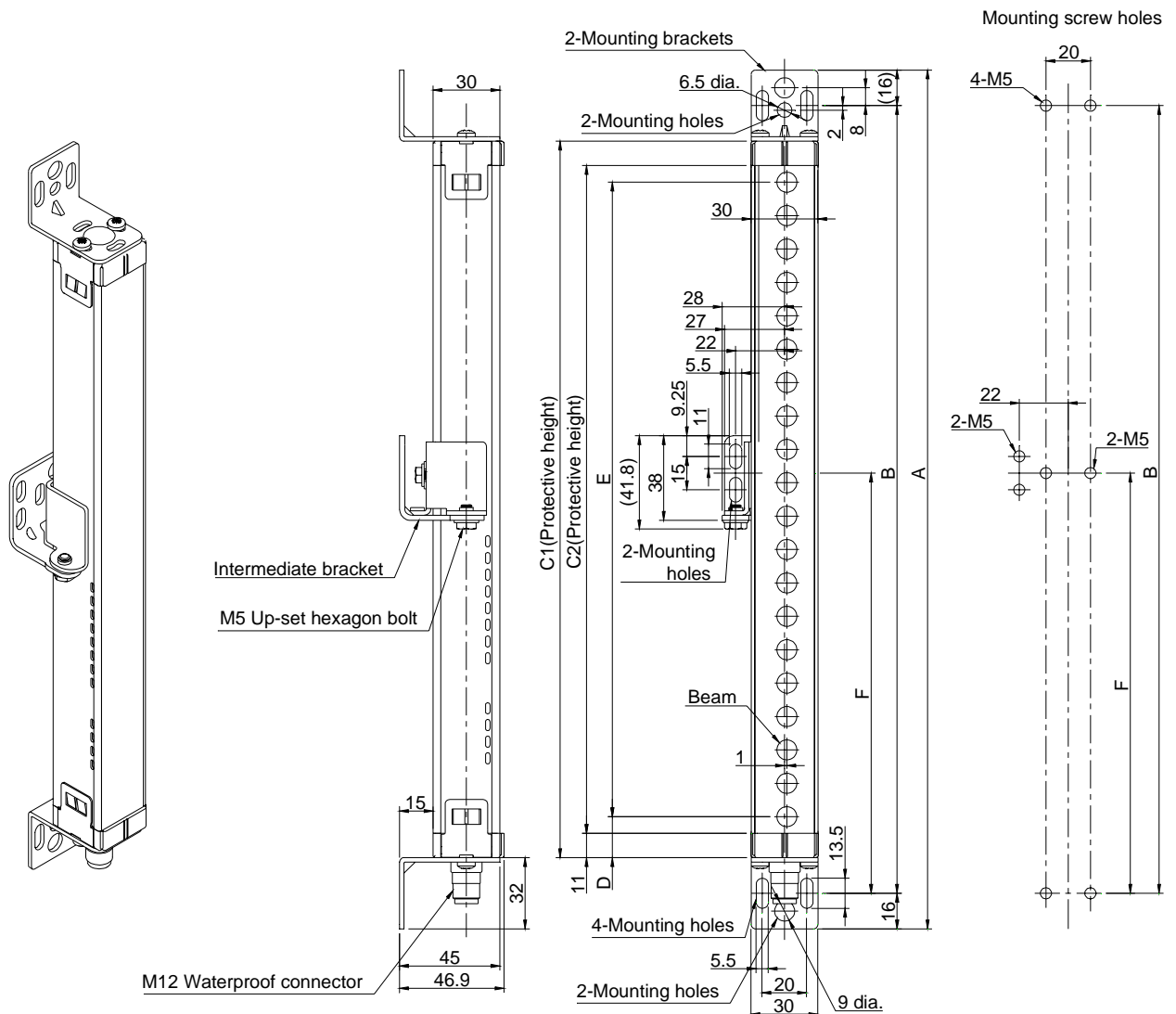



## Section 2 Wiring and Mounting

The following figures show only dimensions which are different from those of the F3SN-A□□□□P□□

### ● F3SN-A□□□□P□□-01

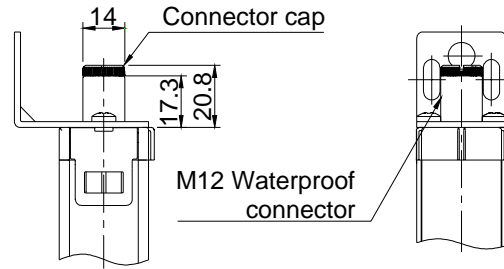
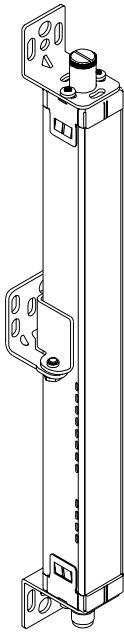

### ● F3SN-A□□□□P□□-02

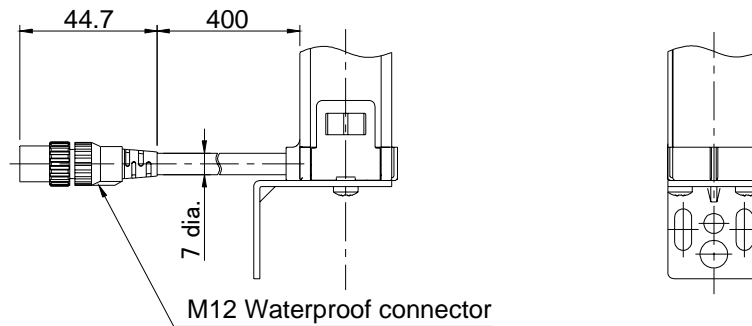
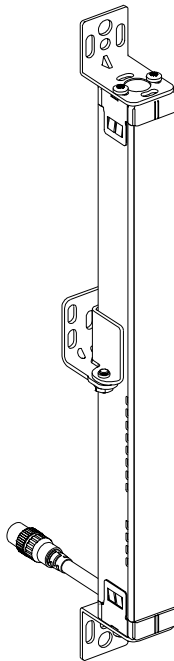

### 2-3 Mounting

#### 2-3-1 How to Mount the Unit

- Be sure to have a bend radius of the F3SN-A cable of R36 (mm) or more. Eventual failure of the cable may result.

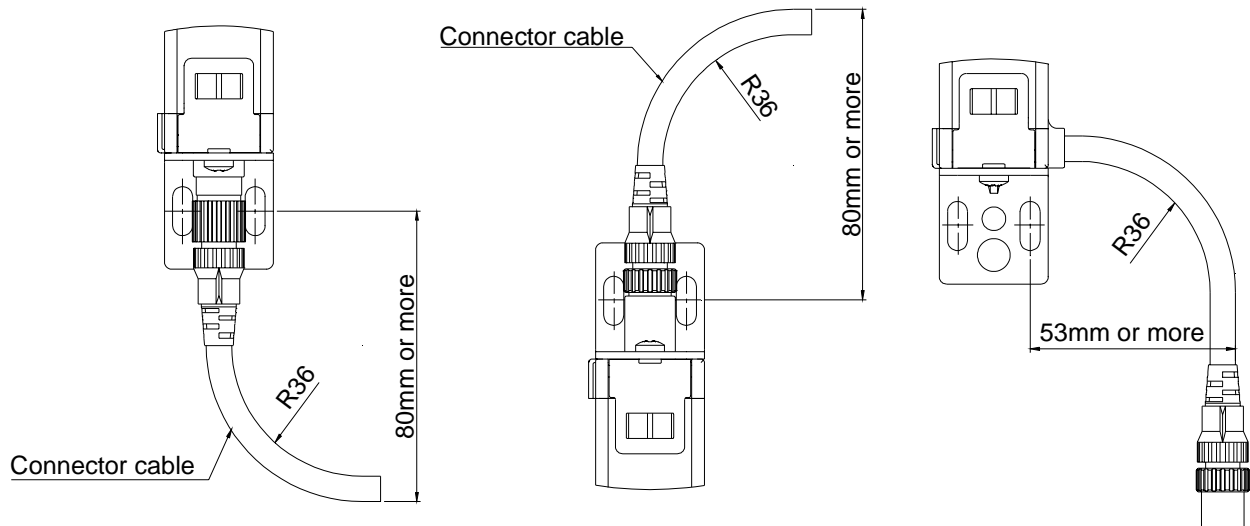

- Shown below with mounting brackets for the emitter and receiver attached. Also shown is how to assemble intermediate mounting bracket and positions where screw holes can be drilled to mount the brackets.

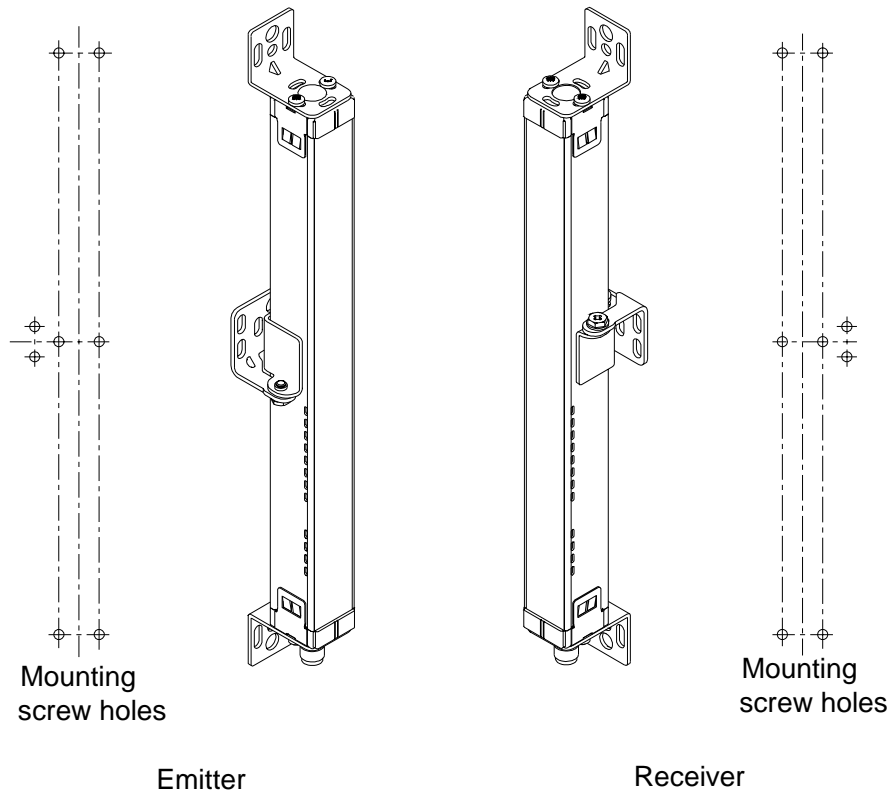

## Section 2 Wiring and Mounting

### 2-3-2 Dimensional Drawing of the Mounting Bracket

- Mounting bracket (top and bottom)

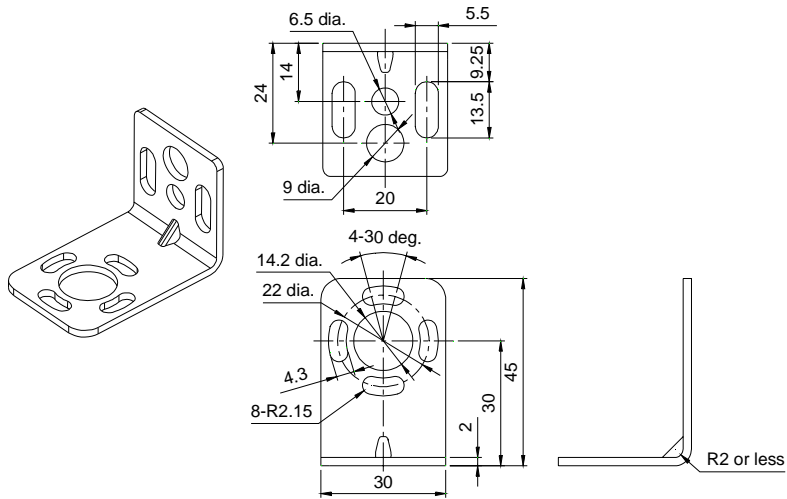

Material: Carbon steel

- Mounting bracket (intermediate)

Configuration for rear mounting

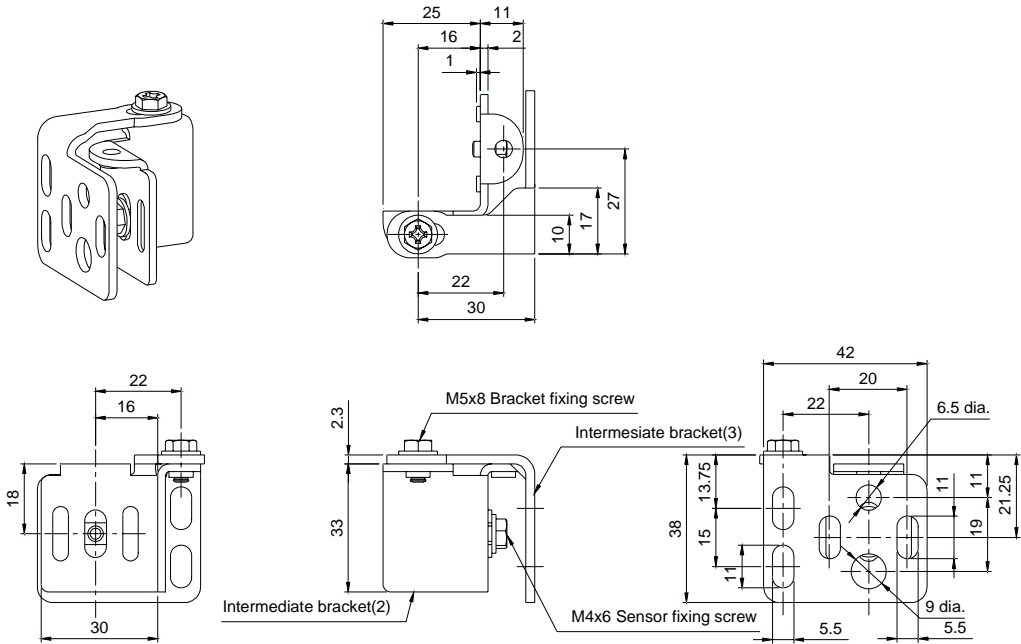

Material: Carbon steel

Configuration for side mounting

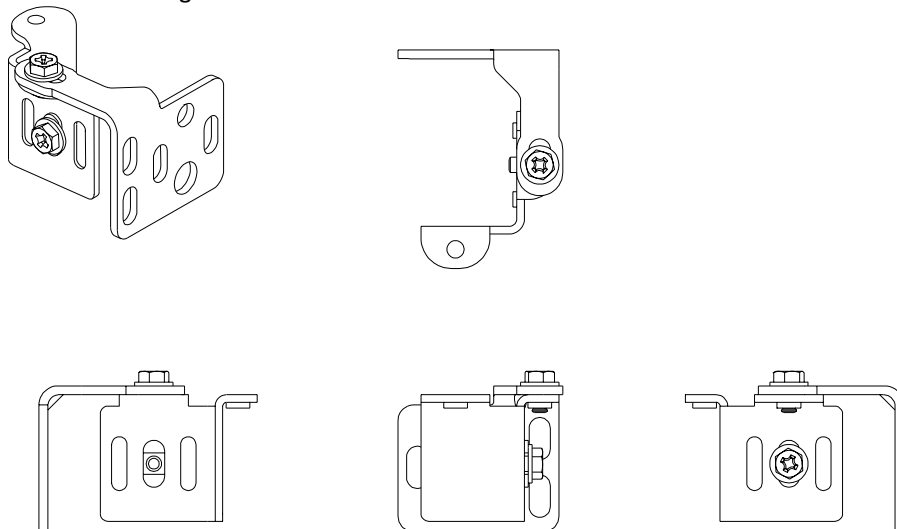

## Section 2 Wiring and Mounting

### Setup procedure when the supplied mounting brackets are used

- I. Secure the bottom bracket (power connector side) on a wall or column.
- II. Secure the intermediate bracket (3) on a wall or column.  
**[Note]:** The intermediate bracket(3) of the receiver is mounted upside down compared with that of the emitter.
- III. Align the intermediate bracket (2) with the protrusion of intermediate bracket (1) located on the rear side of the light curtain, and temporarily tighten the supplied screw (M4x6).  
**[Note]:** Mount the intermediate bracket (2) so that its direction is the same as that of the intermediate bracket (3).
- IV. Insert the cable connector of the light curtain into the bottom bracket.
- V. Move the intermediate bracket (2) until its height is aligned with that of the intermediate bracket (3)(V-a), securely tighten the screw (M4x6)(V-b).  
**[Note]:** Be sure to perform this step prior to mounting the top bracket (cap side).
- VI. After having aligned the intermediate bracket (2) with the intermediate bracket (3) in the direction of mounting the light curtain, temporarily tighten the supplied screw (M5x8). Intermediate brackets (2) and (3) are assembled in the following three ways; VI-a, VI-b, VI-c.
- VII. Align the top bracket (cap side) with the round hole on the cap, and secure it on a wall or column.
- VIII. Insert two supplied screws (M4x8) into both top and bottom brackets, and temporary tighten them (VIII-a, VIII-b). (The figure shown below describes the side mounting.)
- IX. Adjust the torsion angle of the light curtain in the point where the five light receiving level indicators are lit.
- X. Securely tighten the bottom and top brackets.
- XI. Then, securely tighten the intermediate brackets. The procedure to mount the light curtain is now complete.

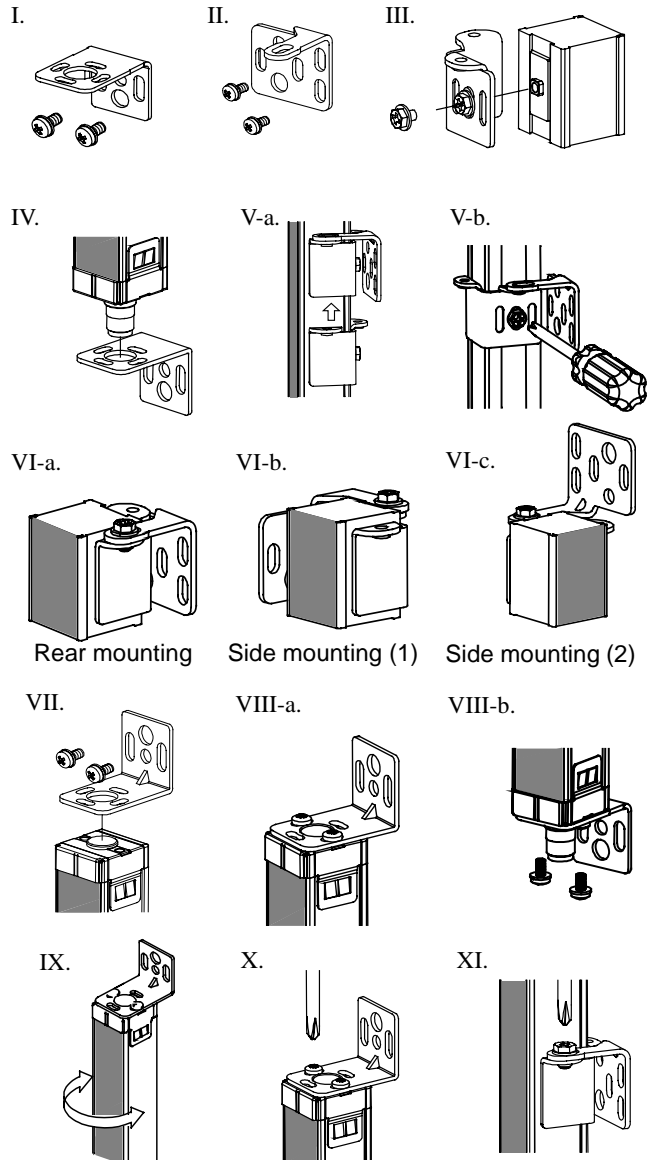

[Rear mounting]

[Side mounting]

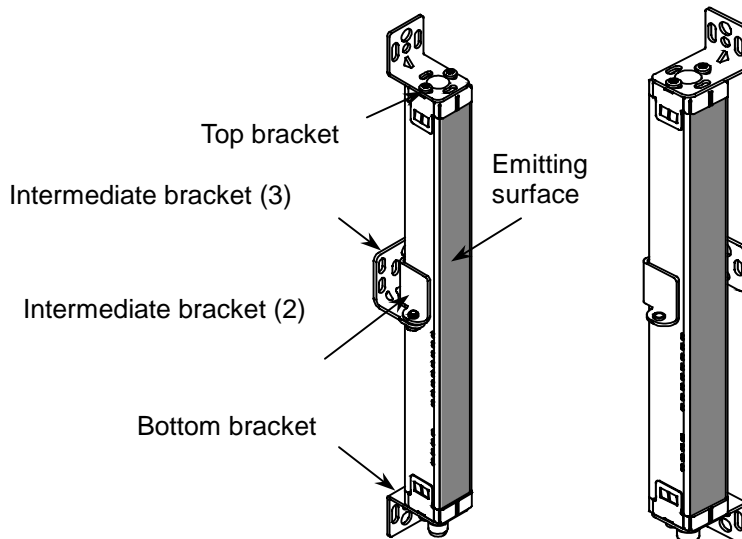

## Section 2 Wiring and Mounting

### 2-4 Wiring



#### WARNING

Do not short-circuit the outputs to the +24V. Doing so will cause the output to be always ON, creating a hazardous situation. Connect the 0V line of the power supply directly to protective earth to prevent the earth fault. Otherwise the earth fault causes the outputs to be ON. (Chapter 2-4)

Connect loads between the output and 0V line. (PNP output)

Connecting loads between the output and +24V line will reverse the operation mode and the machine will be ON when it is light-interrupted.

Always use the two OSSD outputs to configure the safety system.

Using only one OSSD of the safety system may result in serious injury when there is an output circuit failure.

Do not connect any of the F3SN-A lines to a DC power supply with more than 24VDC+10% or to an AC power supply to avoid the danger of electric shock.

(Correct)

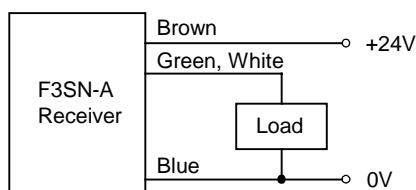

(Incorrect)

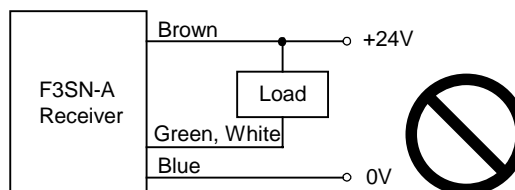

#### 2-4-1 Power Supply Units



#### WARNING

DC power supply units must satisfy all of the conditions below so that the F3SN-A can comply with the applicable standards IEC 61496-1, and UL 508.

- The power supply voltage must be within specified ratings (24 VDC  $\pm$  10 %).
- The power supply is connected only to the F3SN-A and to the devices related to the electro-sensitive protective function of the F3SN-A, such as a safety controller and muting sensors, and it has enough rated current for all the devices. The power supply must not be connected to other devices or machines.
- The power supply uses double or reinforced insulation between the primary and secondary circuits
- The power supply automatically resets overcurrent protection characteristics (voltage drop).
- The power supply maintains an output holding time of at least 20 ms.
- FG (frame ground terminal) must be connected to PE (protective earth) when using a commercially available switching regulator.
- The power supply must have output characteristics of Class 2 Circuit of Limited Voltage-Current Circuit as defined in UL508 (see "Remark").
- The power supply must conform to regulatory requirements and standards, regarding EMC and electrical equipment safety, of the country where the F3SN-A is installed and where machinery will be operated. Example: The EMC Directive (industrial environment) and the Low Voltage Directive in EU.

**[Remark]** The power supply must conform to the following requirement (1) or (2) regarding a secondary circuit, in accordance with UL 508, to avoid a fire.

- 1) The power supply includes a limited voltage/current circuit supplied by an isolating source like the secondary winding of an isolating type transformer. And, in the limited voltage/current circuit,
  - the current available is limited to a value not exceeding 8 A (including the case of short-circuit), or
  - a secondary fuse or other such secondary circuit protective device used to limit the available current shall be rated at not more than a value 4.2 amperes (for the power supply voltage of 24VDC)

**Recommended power supply:** S82K (15 W, 30 W, 50 W, 90 W type) made by OMRON.  
Certificate of UL Listing (UL508, Class2 Output) and CE Marked (EMC and Low Voltage Directives).

- 2) The power supply includes a Class 2 circuit supplied by an isolating source that complies with the requirement in the Standard for Class 2 Power Units, UL 1310, or the requirements in the Standard for Class 2 and Class 3 Transformers, UL 1585.

## 2-4-2 Wiring Diagram

- Light curtain only

### Wiring for the Manual reset mode and the EDM function

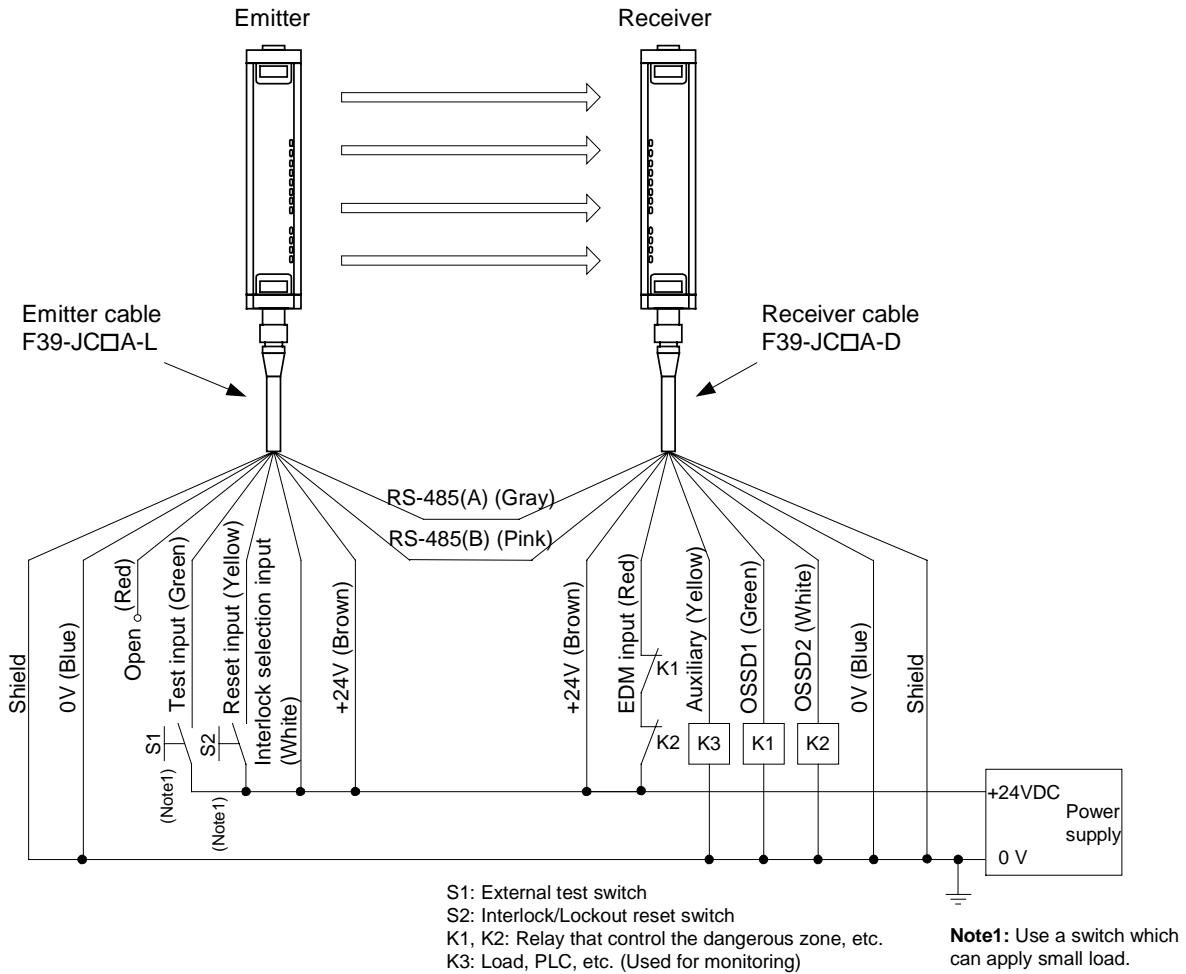

### Wiring for the Auto reset mode

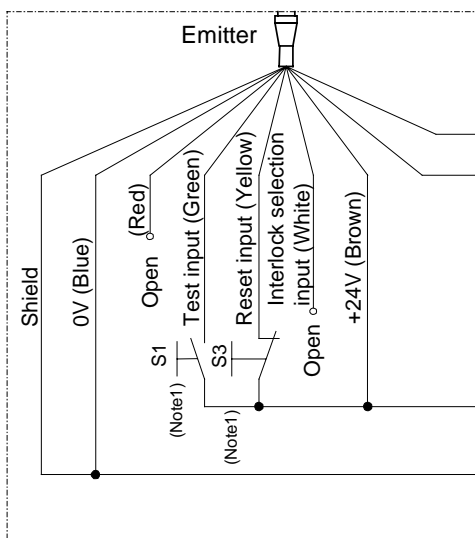

S3: Lockout reset switch  
 (If the switch is not necessary, connect between the reset input and +24VDC.)

### Wiring when the EDM is not used

When the EDM is not necessary

- 1) Use the F39-MC11 to disable the EDM, or
- 2) If the auxiliary output is in the "Dark-ON output mode", wire the lines as shown in the figure below to disable the EDM.

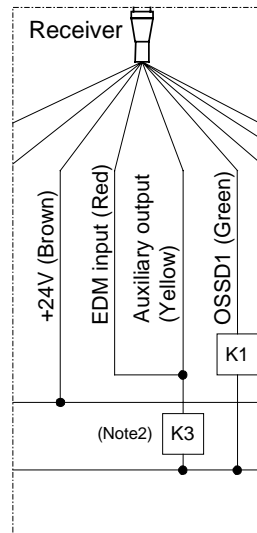

## Section 2 Wiring and Mounting

### ● Combination with the F3SP-B1P

#### Wiring for the Manual reset mode and the EDM function

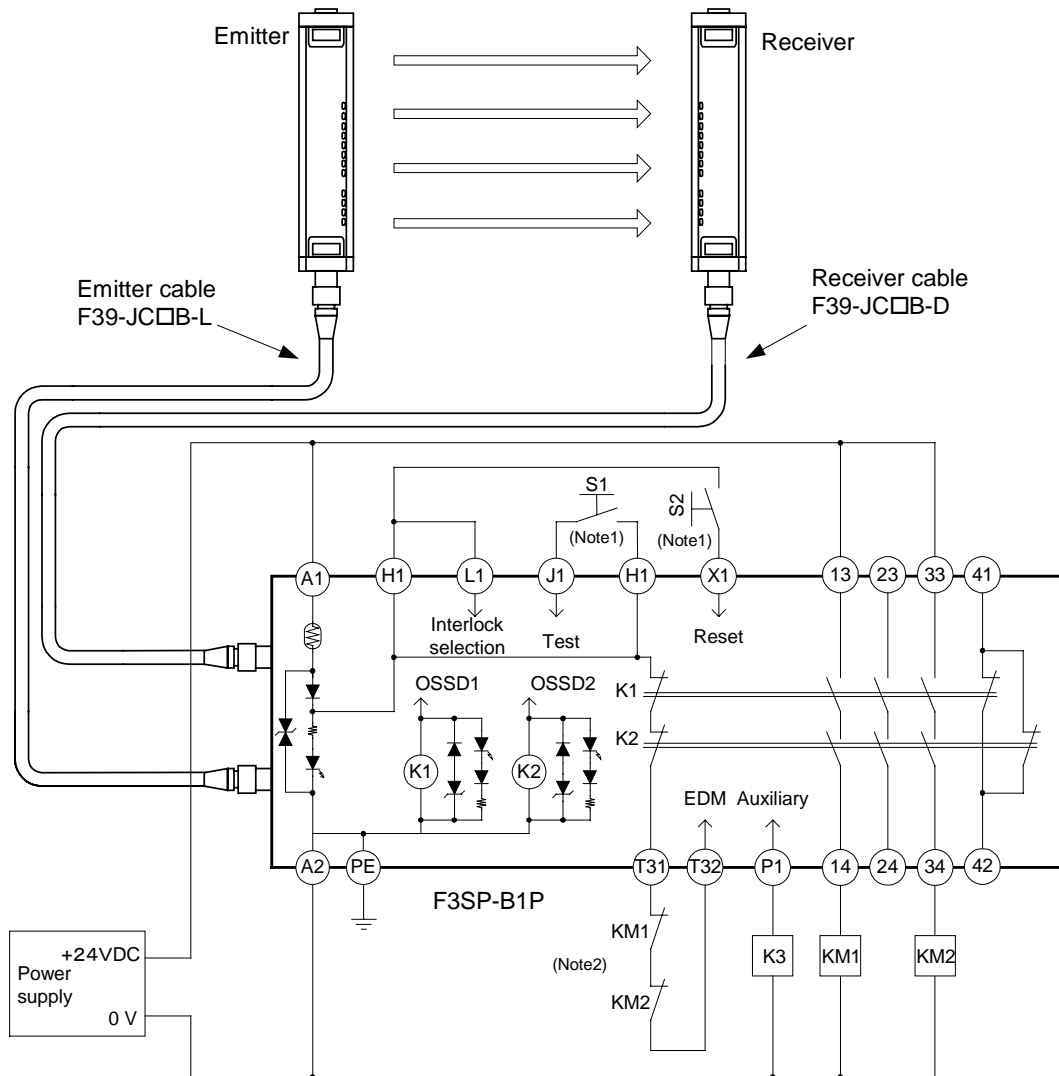

S1: External test switch  
 S2: Interlock/Lockout reset switch  
 KM1, KM2: Relay that control the dangerous zone, etc.  
 K3: Load, PLC, etc. (Used for monitoring)

#### Wiring for the Auto reset mode

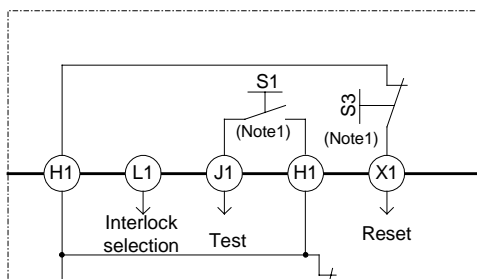

S3: Lockout reset switch  
 (If the switch is not necessary, connect between X1 and H1.)

**Note1:** Use a switch which can apply small load.  
**Note2:** If the EDM is not necessary, short-circuit T31 and T32.

### 2-4-3 Wiring Procedures

1. Connect the emitter cable (F39-JC□□-L optional, gray color outer jacket) to the emitter.
2. Connect the receiver cable (F39-JC□□-D optional, black color outer jacket) to the receiver.
3. Connect the 0V line of the power supply directly to protective earth (PE).

**[Note]:** Be sure to wire correctly. Failure to do so may damage the F3SN-A. Confirm the color of cables and outer jackets (emitter: gray, receiver: black). Matching colors prevents incorrect wiring.

#### ● Connector (Main Unit End)

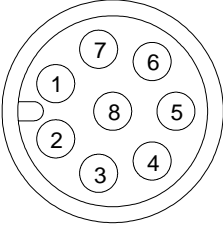
Front View	Pin No.	Signal Name		Wire Color of Optional Cable
		Receiver	Emitter	
	1	OSSD 2	Interlock selection input (INTERLOCK)	White
	2	+24 VDC (24VDC)	+24 VDC (24VDC)	Brown
	3	OSSD 1	Test input	Green
	4	Auxiliary output	Reset input (RESET)	Yellow
	5	RS-485 (A)	RS-485 (A)	Gray
	6	RS-485 (B)	RS-485 (B)	Pink
	7	0 V	0 V	Blue
	8	EDM input	N.C.	Red

#### ● Single-ended connector cable (F39-JC□□A Optional)

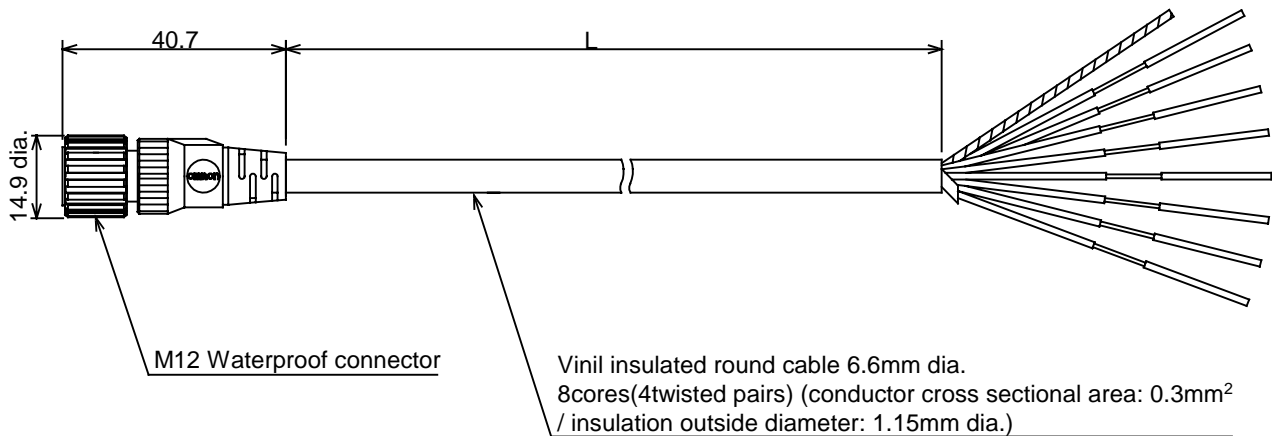

Unit: mm

Type (set name)	For Emitter		For Receiver		L
F39-JC3A	F39-JC3A-L	Gray outer jacket color	F39-JC3A-D	Black outer jacket color	3000
F39-JC7A	F39-JC7A-L		F39-JC7A-D		7000
F39-JC10A	F39-JC10A-L		F39-JC10A-D		10000
F39-JC15A	F39-JC15A-L		F39-JC15A-D		15000



## Section 2 Wiring and Mounting

- Double-ended connector cable for Series Connection and Connection to the F3SP-B1P (F39-JC□B Optional)

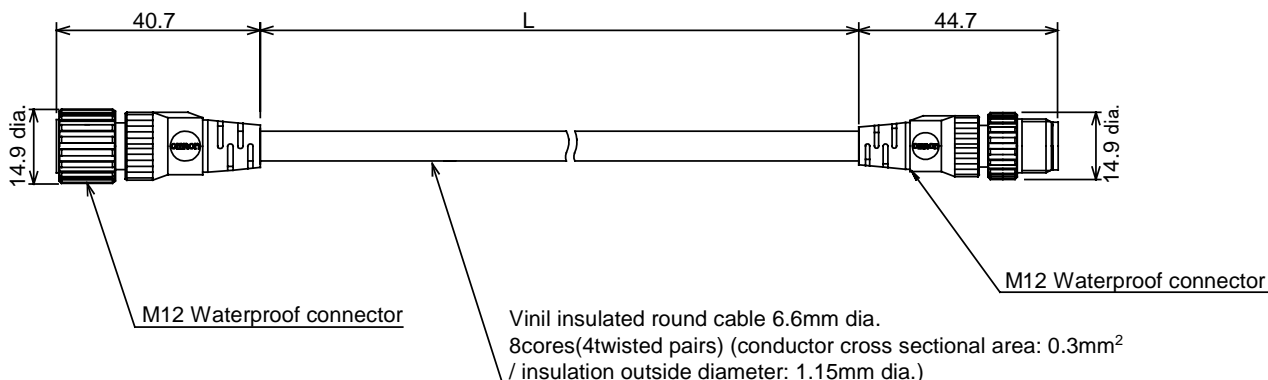

Unit: mm

Type (set name)	For Emitter		For Receiver		L	
F39-JCR2B	F39-JCR2B-L	Gray outer jacket color	F39-JCR2B-D	Black outer jacket color	200	
F39-JC3B	F39-JC3B-L		F39-JC3B-D		3000	<b>Note</b>
F39-JC7B	F39-JC7B-L		F39-JC7B-D		7000	<b>Note</b>
F39-JC10B	F39-JC10B-L		F39-JC10B-D		10000	<b>Note</b>
F39-JC15B	F39-JC15B-L		F39-JC15B-D		15000	<b>Note</b>

[Note]: Do not use for series connection.

### 2-4-4 Adjustment Procedures

#### [Procedures]

1. Ensure the following points.

- The optical surfaces of the emitter and receiver are clean.
- There should be no light-interrupting objects in the F3SN-A detection zone.

2. Adjust the beams of the emitter.

Adjust the torsion angle of the emitter while monitoring the light intensity level indicators and locate the emitter in the point where the light intensity level indicators are lit.

3. Adjust the receiver.

Adjust the torsion angle of the receiver while monitoring the light intensity level indicators and locate the receiver in the point where the light intensity level indicators are lit.

4. Confirm all the light intensity level indicators are lit.

5. When the above adjustments have been completed, tighten all brackets and mounting screws while being careful not to change the beam adjustment for the light curtain.

Mounting bracket type	Screw designation and length (mm)	Tightening torque
Mounting bracket (Top and bottom)	M4×8	1.2 N·m
Mounting bracket (Intermediate)	M4×6	1.2 N·m
	M5×8	2.0 N·m

6. If all of the light intensity level indicators are not lit through the above angle adjustment of the receiver, check for parallelism between the emitter mounting surface and the receiver mounting surface and also check if the emitter and receiver are mounted to the same height.

### 2-5 Check List

A person in charge should check the following check boxes.

**Check the following items to make sure the installation is correct.**

1.  Machine structure does not hinder stop and other safety functions.
2.  Intrusion into a hazardous part of the machine is not possible without passing through the F3SN-A detection zone.
3.  Protective structure allows the F3SN-A to detect an operator when he/she works in the hazardous area.
4.  The switch to reset the interlock condition has to be installed so that the entire hazardous area is visibly free and the switch can not be operated from within the hazardous area.
5.  The safety distance has been calculated. Calculated distance:  $S = ( \quad )$  mm
6.  The actual safety distance is greater than the calculated distance. Actual distance =  $( \quad )$  mm
7.  Reflective surfaces are not installed in prohibited areas.

**Check the following items to make sure wiring is correct before turning ON power.**

1.  The power supply is connected only to the F3SN-A and to the devices related to the electro-sensitive protective function of the F3SN-A, such as a safety controller and muting sensors, and it has enough rated current for all the devices.
2.  The power supply unit is a 24 VDC unit that conforms to the EMC Directive, Low-voltage Directive, and output holding specifications.
3.  The polarity of the power supply connection is not reversed.
4.  The emitter cable is properly connected to the emitter and the receiver cable is properly connected to the receiver.
5.  Double insulation is used between I/O lines and the hazard potential (commercial power supplies, etc.).
6.  Outputs are not shorted to the +24V line.
7.  Loads are not connected to the +24V line.
8.  No lines are connected to a commercial supply line.
9.  When two or more units are used, they are connected or installed properly to prevent mutual interference.

**Check the F3SN-A operations with the machine stopped.**

1.  A test rod is not deformed. (note 1)

2.  Nothing is present in the detection zone.

The power indicator and all of the light intensity level indicators are lit within one second after the F3SN-A is turned ON.

3.  A test rod can be detected at any position in the detection zone. In other words, all the light intensity level indicators go off and the OFF-state indicator remains lit as long as the test rod is present in the detection zone.

Guide the test rod through detection zone as shown in the figure. (Note2)

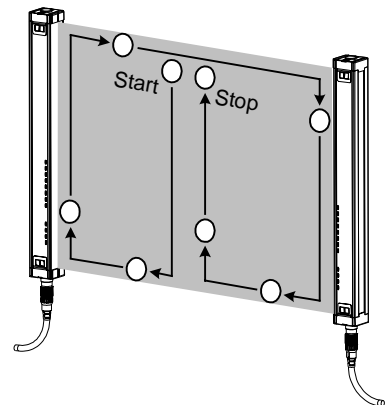

**[Note1]:** The size of the detection capability varies depending on the light curtain type and the floating blanking setting. Perform inspection using a test rod with a proper diameter. (Test rod is not supplied with the F3SN-A□□□□P70 series.)

The diameter of the supplied test rod is not suitable for the inspection when the floating blanking function is used.

Prepare the test rod of the proper diameter. (Refer to “1-2-7 Floating Blanking function”).

**[Note2]:** When the fixed blanking is used, confirm that all entries to the disabled detection zone are blocked by protective structures and the test rod can be detected at any position in the detection zone.

---

## Section 2 Wiring and Mounting

---

4.□ In case the external test function is used:

When the test input line is short-circuited to the 9DC to24V line, the OFF-state indicator is lit.

5.□ In case the EDM function is used:

When the light curtain is interrupted and the EDM input line becomes open, the light curtain enters the lockout condition.

6.□ In case the start interlock function is used:

Even if the light curtain receives light after turning power ON, the OFF-state indicator remains lit. If the reset input is applied, the ON-state indicator is lit.

7.□ In case the restart interlock function is used:

When the light curtain is interrupted, then go back to the light receiving condition, the OFF-state indicator remains lit. If the reset input is applied, the ON-state indicator is lit.

### **Operate the machine and check to see if a hazardous part stops under the conditions below.**

1.□ The hazardous part immediately stops when a test rod is intruded in the detection zone at 3 points: directly in front of the emitter, directly in front of the receiver, midway between the emitter and receiver. (Use correct test rod as described in Step 3.)

2.□ The hazardous part remains stopped as long as the test rod is present in the detection zone.

3.□ The hazardous part stops when the F3SN-A power supply is turned OFF.

4.□ The overall measured machine response time is less than the calculated time.

# Section 3 I/O Circuit

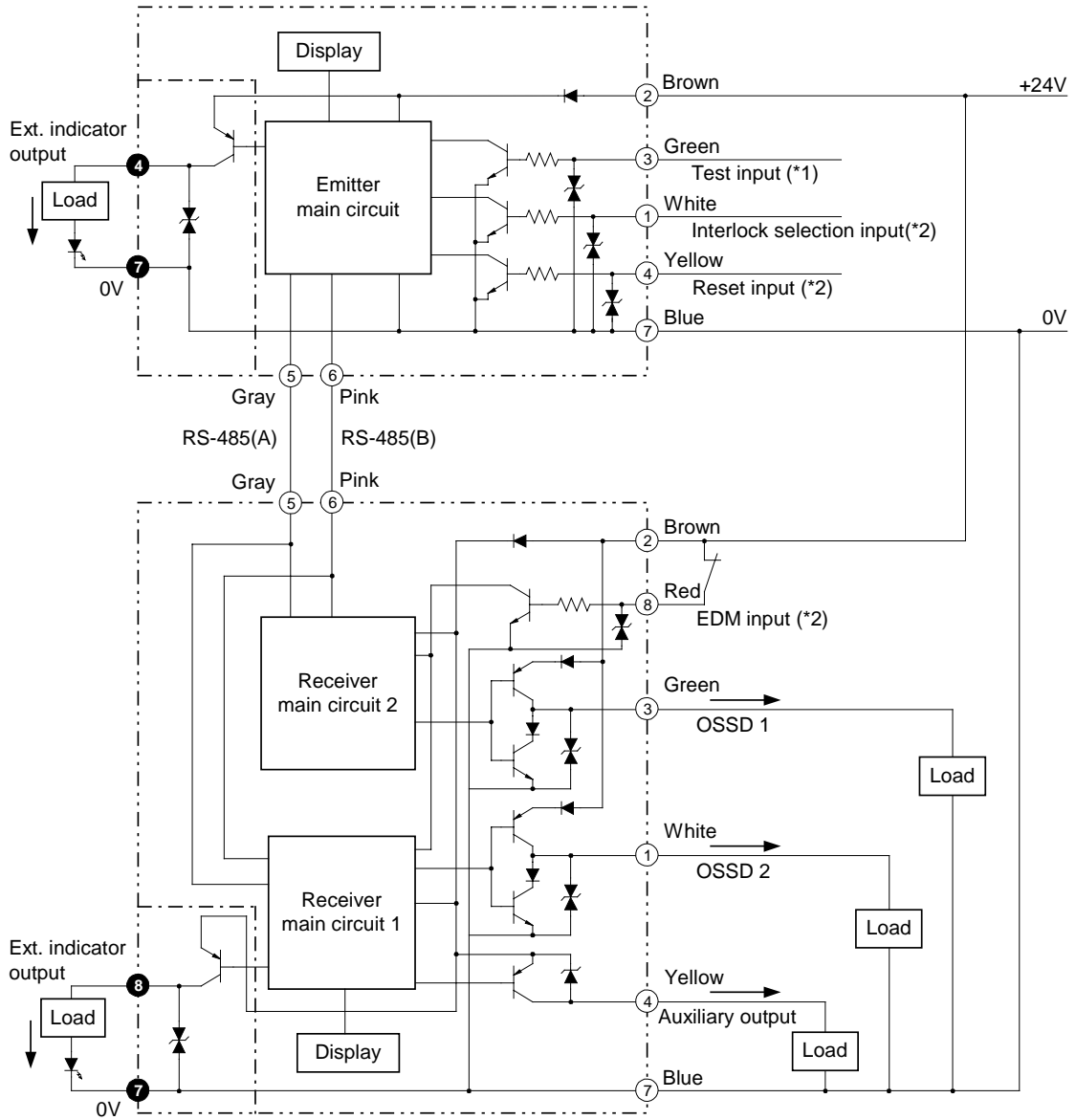

- \*1. Open: normal light emission, Short to the +24VDC: stops light emission
- \*2. Refer to 2-4-2 Wiring Diagram
- \*3. The section encircled with the dashed line is applied for F3SN-A□□□□P□□-01 only.

**[Note]:** The numbers in ○ indicate pin numbers of the connectors.  
 The numbers in ● indicate pin numbers of the series connection connectors.

## Section 3 I/O Circuit

### Output Waveform of the OSSD outputs

The OSSD outputs will be OFF as shown in the following figure in order to perform the OSSD circuit self-test when the light curtain is in the ON-state. The OSSD circuit diagnosis is correct when this OFF signal is fed back. If the output signal does not contain an OFF signal, the receiver determines that there is an output circuit or wiring failure and goes into the lockout condition.

The number of OFF signals depends on the number of light curtains connected in series. (See the table below.)

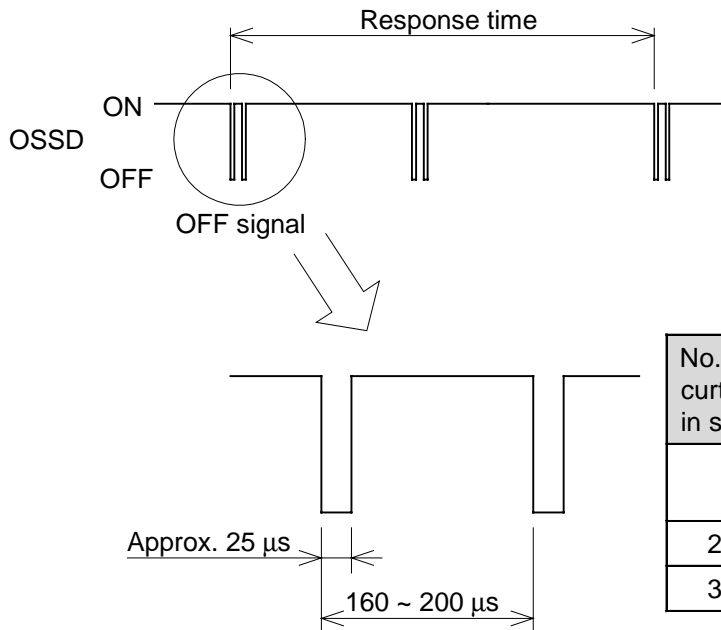

No. of light curtains connected in series	No. of OFF signals within the response time
No series connection	1
2 light curtains	2
3 light curtains	3

In the same way, the OSSD outputs will be ON as shown in the following figure, to perform the OSSD circuit self-test when the light curtain is in the OFF-state.

Check the input response time of a machine connected to the F3SN-A carefully to ensure the machine will not malfunction due to the OFF signal.

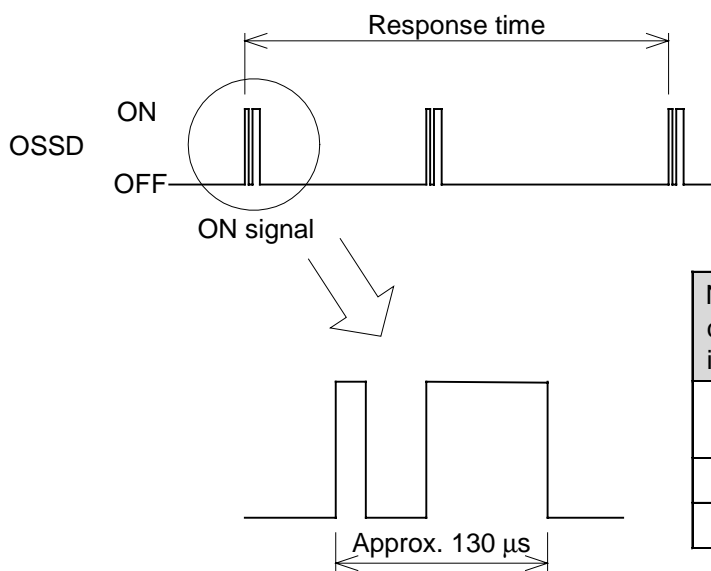

No. of light curtains connected in series	No. of ON signals within the response time
No series connection	1
2 light curtains	2
3 light curtains	3

# Section 4 Application

This section shows examples of a motor control system that combines an F3SN-A. These are category 4 systems (EN954-1 provision).

## ● Application 1

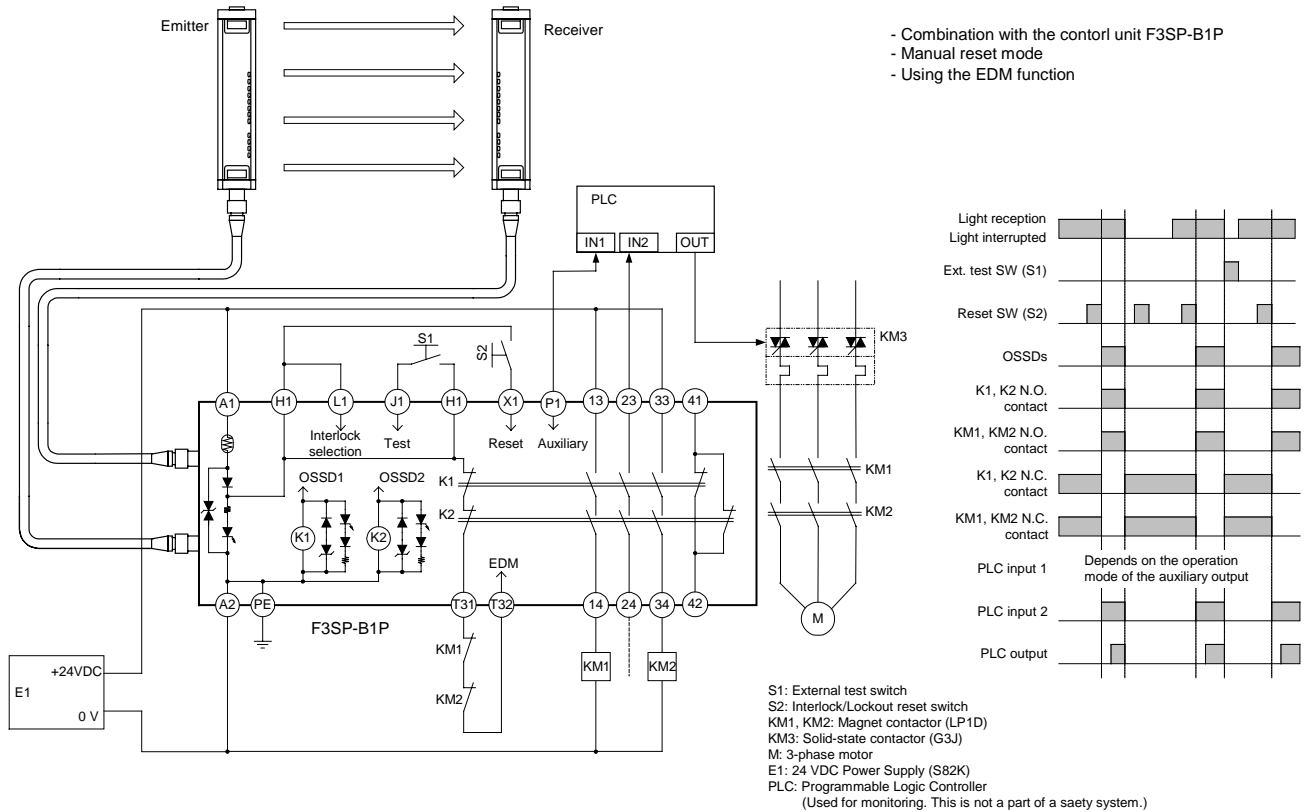

## ● Application 2

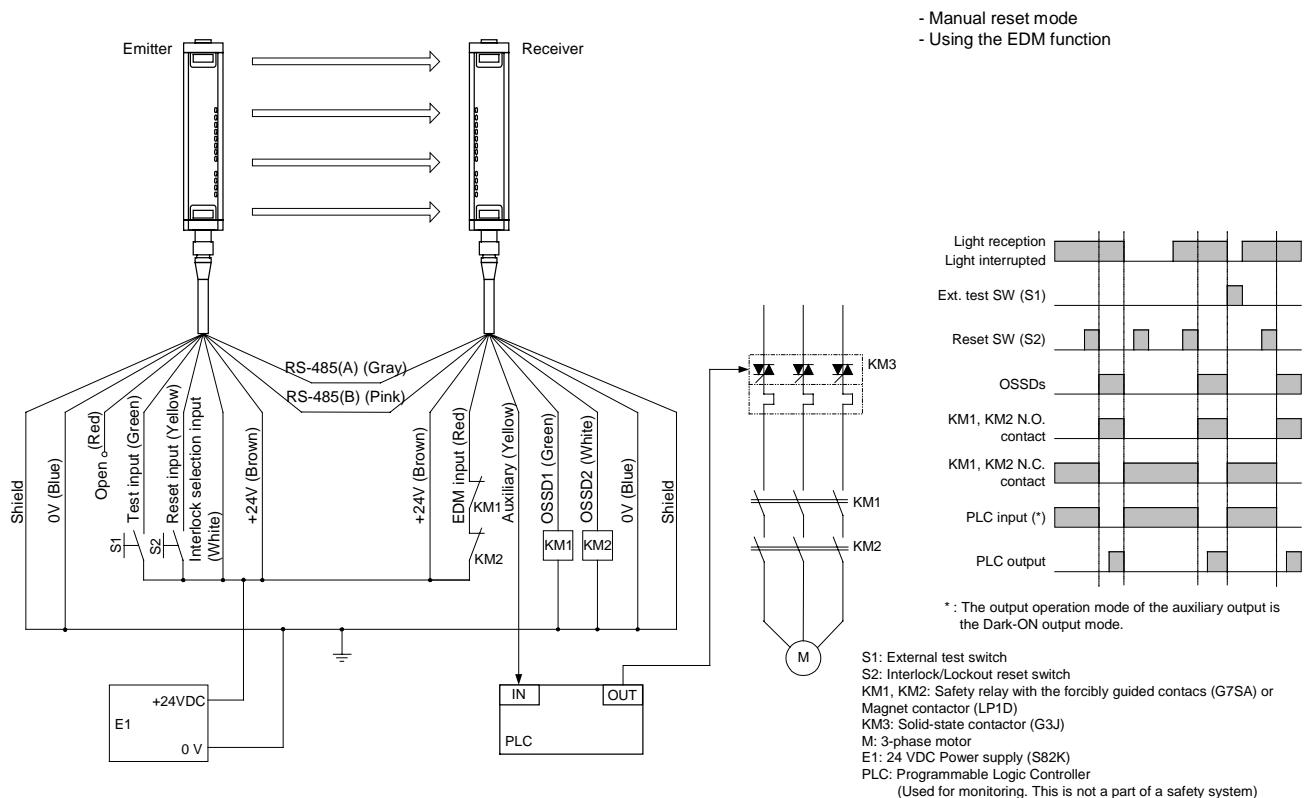

# Section 4 Application

## ● Application 3

- Combination with the safety relay unit G9SA-301
- Setting of the F3SN-A
  - Auto reset mode
  - Disabled the EDM function by the F39-MC11
- Setting of the safety relay unit
  - Manual reset mode
  - Using feedback loop
- Using an emergency stop switch

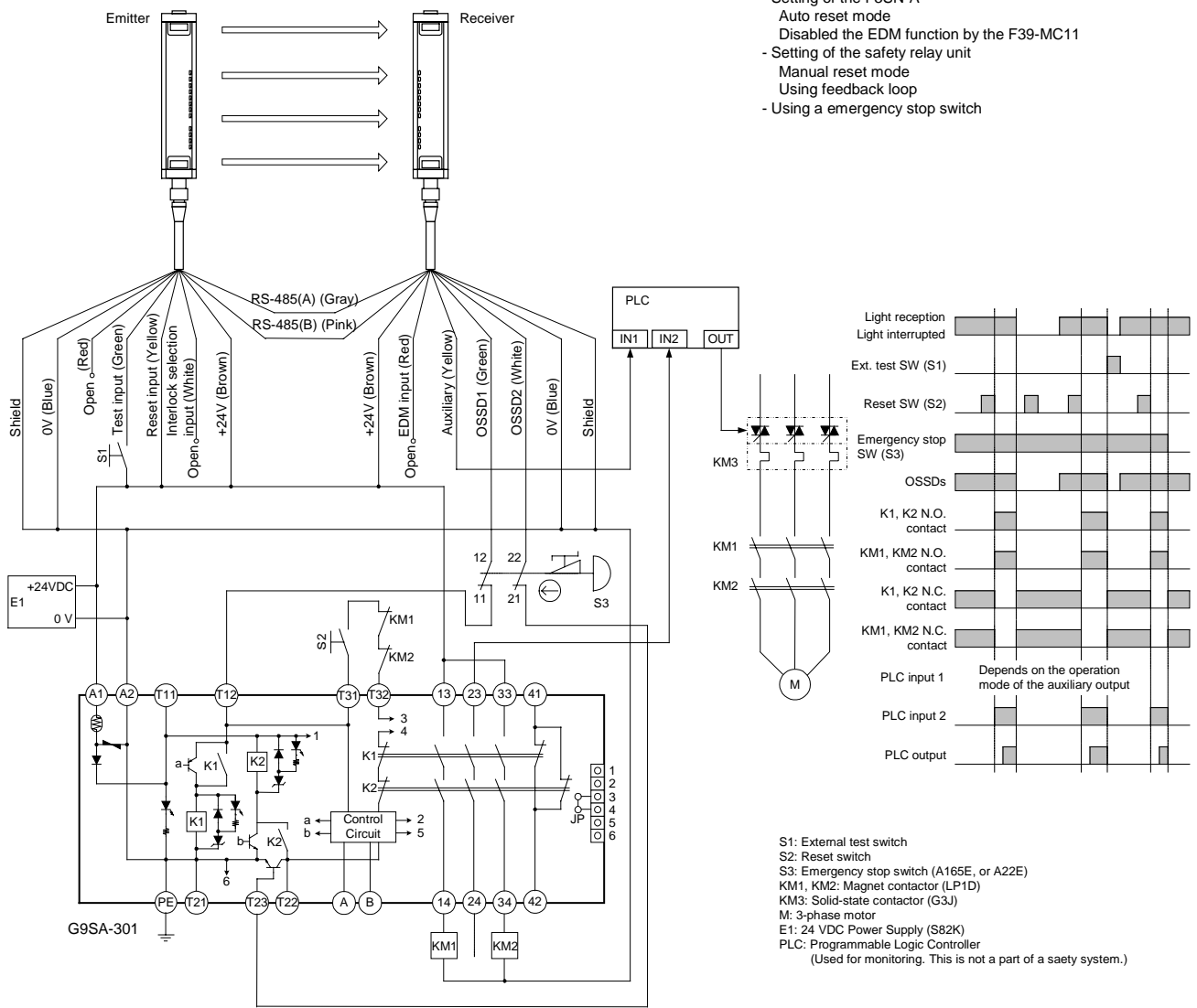

## Section 5 Maintenance



### WARNING

Do not use the F3SN-A until the following inspections are completed. Failure to do so may result in loss of life or serious injury.

Do not disassemble, repair or modify the F3SN-A.

**[Note]:** For safety, be sure to record and store inspection results.

Make sure you are thoroughly familiar with the F3SN-A and the machine prior to conducting an inspection.

If the installer, design technician and user are different individuals, make sure the user has adequate guidelines for performing maintenance.

### 5-1 Daily Inspections

**Be sure to inspect the following items at the start of work or after a shift change.**

1.  No instruction paths into dangerous machine parts except through the F3SN-A detection zone.
2.  Some part of the operator's body remains in the F3SN-A detection zone at all times while working in dangerous machine parts.
3.  The actual safety distance is greater than the calculated distance.
4.  No dirt or scratches on the optical surface or the spatter protection cover (the F39-HN, optional) of the F3SN-A.
5.  A test rod is not deformed.
6.  Confirm nothing is present in the detection zone, then turn on the power of F3SN-A.

When the start interlock is not used: The power indicator and the ON-state indicator are lit within one second after turning ON the power.

When the start interlock is used: The power indicator and the OFF-state indicator are lit within one second after turning ON the power.

7.  The test rod can be detected when guiding it through detection zone as shown in the figure.

In other words, all the light intensity level indicators go off and the OFF-state indicator remains lit when the test rod is inserted into the detection zone.

**[Note]:** Perform inspection with the proper size test rod in accordance to the light curtain type and the floating blanking setting.

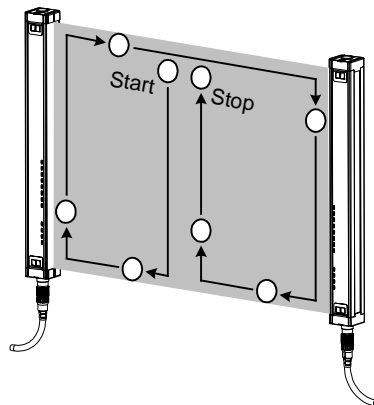

**Operate the machine and check to see if the dangerous part stops under the conditions below.**

8.  The dangerous part moves when there is nothing in the detection zone.
9.  The dangerous part stops immediately when the test rod is inserted into the detection zone directly in front of the emitter, directly in front of the receiver and midway between the emitter and receiver. (Use the correct test rod)
10.  The dangerous part remains stopped as long as the test rod is present in the detection zone.
11.  The dangerous part remains stopped when the F3SN-A power supply is turned OFF.



### 5-2 Inspections Every Six Months

**Inspect the following items every six months or when a machine setting is changed.**

1.  Machine structure does not hinder stop and other safety functions.
2.  There is no machine modification or connection change that will adversely affect the control system.
3.  F3SN-A outputs are correctly wired to the machine.
4.  The actual overall response time of the machine is less than the calculated response time.
5.  The control relay and/or contactor are good condition.
6.  The screws for brackets are secured tightly.
7.  There is no interference light.







## Section 6 Troubleshooting

### 6-1 Lockout condition

When the light curtain enters the lockout condition, the error content will be displayed by a flashing pattern of the Error mode indicator.

Devise a countermeasure in accordance with the following table.

[Note]: For some error conditions, either only the emitter or receiver will flash.

Error mode indicator	Cause		Remedy
A B C 	<b>Wiring error for interlock function setting</b>	1) The reset input line and the interlock selection input line are not wired correctly. 2) The interlock selection input line became open or shorted during power-on.	1)-2) Confirms the wiring for the auto reset mode or the manual reset mode.
A B C 	<b>Error of the EDM function</b>	1) One of the external relay contacts is welded. 2) The EDM input line is not wired correctly to the external relays. 3) The setting value of relay monitoring time is lower than the relay response time. 4) In the case of connecting the EDM input line to the auxiliary output line in order to make the EDM function inactive, lines are open or shorted to the 0 V line.	1) Replace the relay. 2) Check connection of the relay monitoring input line. 3) Replace with a relay of proper release time, or change the setting value of the relay monitoring time by the F39-MC11. 4) Check the EDM input line and the auxiliary output line for error. Then, confirm that the operation mode for the auxiliary output is in the Dark-ON output mode.
A B C 	<b>RS-485 communication line error</b>	1) The RS-485 communication line is open or shorted to the other I/O line. 2) Communication error by noises. 3) When the light curtains are connected in series, the connector of the series connection cable is disconnected. 4) Failure of the CPU.	1) Check connection of the RS-485 lines. 2) Check noise environment around the RS-485 communication lines. 3) Check the cable connection between the light curtains connected in series. 4) Replace the light curtain
A B C 	<b>OSSD error</b>	1) OSSD outputs are shorted together 2) At least one OSSD output is shorted to the +24V line, 0V line, or the other I/O line. 3) Failure of OSSD output circuit	1)-2) Rewire the OSSD outputs correctly. 3) Replace the receiver.
A B C 	<b>Error by interference light</b>	1) Interference light is received. 2) The emission light of the other photoelectric sensor is received.	1)-2) Interrupt the interference light. (Refer to 2-1-4)
A B C 	<b>Incorrect configuration on the light curtain connection</b>	1) The type of the receiver is different from the type of the emitter. (e.g. the number of beams is different.) 2) The number of the receiver connected in series is different from that of the emitter.	1)-2) Correct the type or the number of the light curtain connected in series.
A B C 	<b>Error by noises or Destruction of the light curtain</b>	1) Influenced by significant noise. 2) Internal hardware failure of the receiver or the emitter.	1) Check noise environment around the light curtain. 2) Replace the receiver or the emitter.

Flashing Not lit

---

## Section 6 Troubleshooting

---

### 6-2 Other trouble

In case the light curtain does not work, even if the lockout indicator and the error mode indicator are not flashing, devise a countermeasure in accordance with the following table.

Phenomenon	Cause	Remedy
<b>The light intensity level indicator does not lit although any beams are not interrupted.</b>	<ul style="list-style-type: none"><li>1) RS-485 communication lines are not connected.</li><li>2) RS-485 communication lines are influenced by significant noise.</li><li>3) Auxiliary output is connected to + 24V line.</li></ul>	<ul style="list-style-type: none"><li>1) Reconnect the RS-485 line correctly.</li><li>2) Check noise environment around the RS-485 lines.</li><li>3) Open the auxiliary output line, or connect to the 0V line via a load.</li></ul>

## Section 7 Optional Accessory

● Single-ended connector cable (For emitter and for receiver, set of 2)

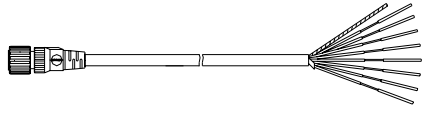
Appearance	Type	Length	Specification
	F39-JC3A	3m	M12 connector (8pins)
	F39-JC7A	7m	
	F39-JC10A	10m	
	F39-JC15A	15m	

● Double-ended connector cable (For emitter and for receiver, set of 2)

Appearance	Type	Length	Specification
	F39-JCR2B	0.2m	M12 connector (8pins)
	F39-JC3B	3m	
	F39-JC7B	7m	
	F39-JC10B	10m	
	F39-JC15B	15m	

● Control unit

Appearance	Type	Output
	F3SP-B1P	Relay (3NO + 1NC)

● Setting console

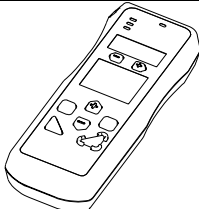
Appearance	Type	Accessory
	F39-MC11	Branching connector, Connector cap, Cable

● External indicator \*Series connection type is required for connection

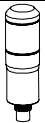
Appearance	Type	Applicable light curtain	Indicator color	Specification
	F39-A01PR-L	Emitter	Red	M12 connector
	F39-A01PG-L		Green	
	F39-A01PR-D	Receiver	Red	
	F39-A01PG-D		Green	

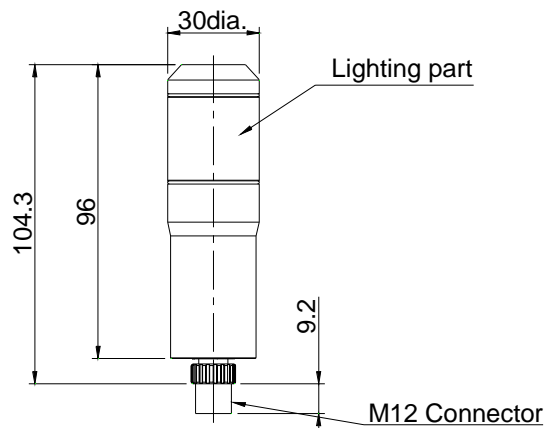

## Section 7 Optional Accessory

### ● Spatter protection cover (for both emitter and receiver, set of 2)

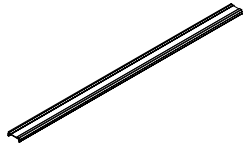
Appearance	Type *1	Applicable light curtain
	F39-HN□□□□-14	F3SN-A□□□□P14 series
	F39-HN□□□□-25	F3SN-A□□□□P25 series F3SN-A□□□□P40 series F3SN-A□□□□P70 series

\*1. The same 4-digit numbers as the protective heights (□□□□ in the light curtain type names) are substituted by □□□□ in the type names.

\*2. The operating range of the light curtain will decrease by 10% when using the spatter protection cover.

[Spatter protection cover]

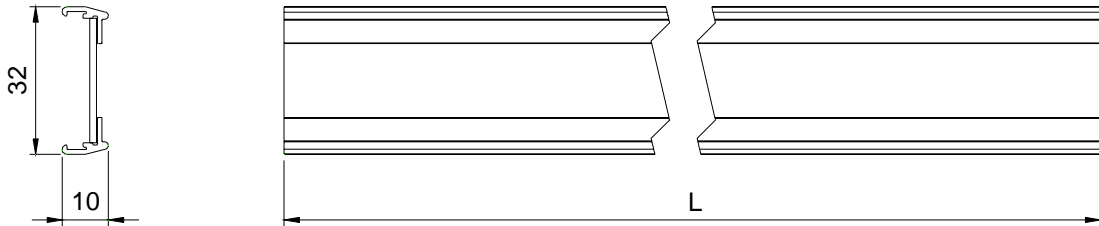

\*L is as follows:

F39-HN□□□□-14	L = □□□□ mm
F39-HN□□□□-25	L = □□□□ - 22 mm

Material:

PC (transparent area)

ABS (non-transparent area)

[Fixing bracket]

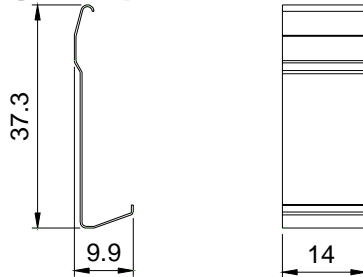

Material:

Stainless steel

[Mounting dimension]

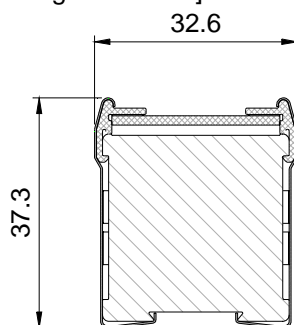

## **Section 8 Referenced standards**

### **International Standards**

- IEC61496-1 Safety of Machinery: Electro-sensitive Protective Equipment – Part 1: General Requirements and Tests
- IEC61496-2 Safety of Machinery: Electro-sensitive Protective Equipment – Part 2: Particular Requirements for Equipment Using Active Opto-electronic Protective Devices

### **European Standards**

- EN61496-1 Safety of Machinery: Electro-sensitive Protective Equipment – Part 1: General Requirements and Tests
- EN954-1 Safety of Machinery: Safety-related Parts of Control Systems – Part 1: General Principles for Design
- EN415-4 Palletizers and depalletizers
- prEN691 Woodworking machines
- EN692 Mechanical presses
- prEN693 Hydraulic presses

### **U.S. Federal regulations**

- OSHA 29 CFR 1910.212 General Requirements of All Machines
- OSHA 29 CFR 1910.217 Mechanical Power Presses

### **U.S. Standards**

- ANSI B11.1 Mechanical Power Presses
- ANSI B11.2 Hydraulic Power Presses
- ANSI B11.3 Power Press Brakes
- ANSI B11.4 Shears
- ANSI B11.5 Iron Workers
- ANSI B11.6 Lathes
- ANSI B11.7 Cold Headers and Cold Formers
- ANSI B11.8 Drilling, Milling, and Boring Machines
- ANSI B11.9 Grinding Machines
- ANSI B11.10 Metal Sawing Machines
- ANSI B11.11 Gear Cutting machines
- ANSI B11.12 Roll Forming and Roll Bending Machines
- ANSI B11.13 Single- and Multiple-Spindle Automatic Bar and Chucking Machines
- ANSI B11.14 Coil Slitting Machines/Systems
- ANSI B11.15 Pipe, Tube, and Shape Bending Machines
- ANSI B11.16 Metal Powder Compacting Presses
- ANSI B11.17 Horizontal Extrusion Presses
- ANSI B11.18 Machinery and Machine Systems for the Processing of Coiled Strip, Sheet, and Standards
- ANSI B11.19 Performance Criteria for the Design, Construction, Care, and Operation of Safeguarding when Referenced by the Other B11 Machine Tool Safety Standards
- ANSI/RIA 15.06 Safety Requirements for Industrial Robots and Robot Systems
- UL1998 Safety-related Software
- UL508 Industrial control equipment