

RFID System

V680S Series

User's Manual
(EtherNet/IP™)

Reader/Writer

V680S-HMD63-EIP

V680S-HMD64-EIP

V680S-HMD66-EIP

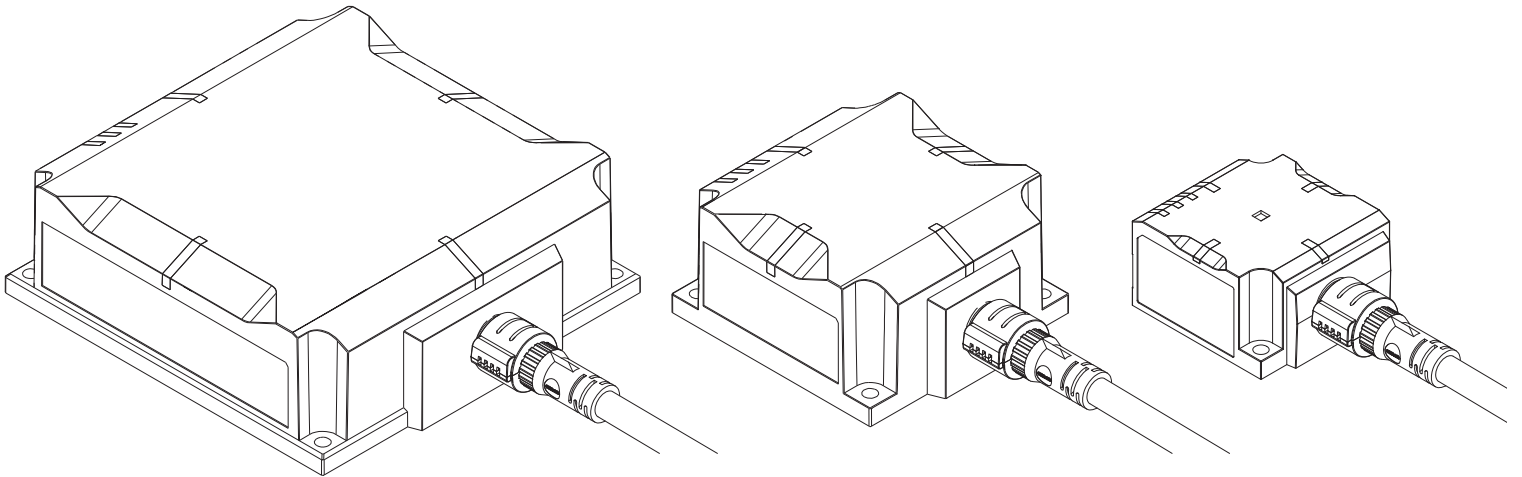

Introduction

Thank you for purchasing a V680S-series RFID System. This manual describes the functions, performance, and application methods needed for optimum use of the V680S-series RFID System.

Please observe the following items when using the V680S-series RFID System.

- Allow the V680S-series RFID System to be installed and operated only by qualified specialists with a sufficient knowledge of electrical systems.
- Read and understand this manual before attempting to use the RFID System and use the RFID System correctly.
- Keep this manual in a safe and accessible location so that it is available for reference when required.

NOTICE

- (1) No part of this publication may be reproduced, stored in a retrieval system, or transmitted, in any form, or by any means, mechanical, electronic, photocopying, recording, or otherwise, without the prior written permission of OMRON.
- (2) Because OMRON is constantly striving to improve its high-quality products, the information contained in this manual is subject to change without notice.
- (3) Every precaution has been taken in the preparation of this manual. Nevertheless, OMRON assumes no responsibility for errors or omissions. Neither is any liability assumed for damages resulting from the use of the information contained in this publication. If you find any problems in this manual, please contact your OMRON representative. If you do so, please provide the Cat. No. that is given at the back of this manual.

Trademarks

- Microsoft, Windows, Windows Vista are either registered trademarks or trademarks of Microsoft Corporation in the USA and other countries.
- ODVA and EtherNet/IP are trademarks of the ODVA.
- Java and other trademarks that contain “Java” are the registered trademarks of Oracle Corporation or its related companies.

Other system names and product names used in this manual are the trademarks or registered trademarks of the respective companies.

Introduction	Terms and Conditions Agreement (Always Read This Information)	Introduction
Section 1	Product Overview	Section 1
Section 2	System Configuration	Section 2
Section 3	Names and Functions of Components	Section 3
Section 4	Installation and Connections	Section 4
Section 5	Preparations for Communications	Section 5
Section 6	Functions	Section 6
Section 7	Host Communications Specifications	Section 7
Section 8	Browser Interface	Section 8
Section 9	Troubleshooting	Section 9
Section 10	Maintenance and Inspection	Section 10
Section 11	Appendices	Section 11

RFID System

V680S-HMD63-EIP
V680S-HMD64-EIP
V680S-HMD66-EIP

Reader/Writer
Reader/Writer
Reader/Writer

User's Manual

Terms and Conditions Agreement

Warranty, Limitations of Liability

1. Warranties

▪ Exclusive Warranty

Omron's exclusive warranty is that the Products will be free from defects in materials and workmanship for a period of twelve months from the date of sale by Omron (or such other period expressed in writing by Omron). Omron disclaims all other warranties, express or implied.

▪ Limitations

OMRON MAKES NO WARRANTY OR REPRESENTATION, EXPRESS OR IMPLIED, ABOUT NON-INFRINGEMENT, MERCHANTABILITY OR FITNESS FOR A PARTICULAR PURPOSE OF THE PRODUCTS. BUYER ACKNOWLEDGES THAT IT ALONE HAS DETERMINED THAT THE PRODUCTS WILL SUITABLY MEET THE REQUIREMENTS OF THEIR INTENDED USE.

Omron further disclaims all warranties and responsibility of any type for claims or expenses based on infringement by the Products or otherwise of any intellectual property right.

▪ Buyer Remedy

Omron's sole obligation hereunder shall be, at Omron's election, to (i) replace (in the form originally shipped with Buyer responsible for labor charges for removal or replacement thereof) the non-complying Product, (ii) repair the non-complying Product, or (iii) repay or credit Buyer an amount equal to the purchase price of the non-complying Product; provided that in no event shall Omron be responsible for warranty, repair, indemnity or any other claims or expenses regarding the Products unless Omron's analysis confirms that the Products were properly handled, stored, installed and maintained and not subject to contamination, abuse, misuse or inappropriate modification. Return of any Products by Buyer must be approved in writing by Omron before shipment. Omron Companies shall not be liable for the suitability or unsuitability or the results from the use of Products in combination with any electrical or electronic components, circuits, system assemblies or any other materials or substances or environments. Any advice, recommendations or information given orally or in writing, are not to be construed as an amendment or addition to the above warranty.

See <http://www.omron.com/global/> or contact your Omron representative for published information.

2. Limitation on Liability; Etc

OMRON COMPANIES SHALL NOT BE LIABLE FOR SPECIAL, INDIRECT, INCIDENTAL, OR CONSEQUENTIAL

DAMAGES, LOSS OF PROFITS OR PRODUCTION OR COMMERCIAL LOSS IN ANY WAY CONNECTED WITH THE PRODUCTS, WHETHER SUCH CLAIM IS BASED IN CONTRACT, WARRANTY, NEGLIGENCE OR STRICT LIABILITY.

Further, in no event shall liability of Omron Companies exceed the individual price of the Product on which liability is asserted.

Application Considerations

1. Suitability of Use

Omron Companies shall not be responsible for conformity with any standards, codes or regulations which apply to the combination of the Product in the Buyer's application or use of the Product. At Buyer's request, Omron will provide applicable third party certification documents identifying ratings and limitations of use which apply to the Product. This information by itself is not sufficient for a complete determination of the suitability of the Product in combination with the end product, machine, system, or other application or use. Buyer shall be solely responsible for determining appropriateness of the particular Product with respect to Buyer's application, product or system. Buyer shall take application responsibility in all cases.

NEVER USE THE PRODUCT FOR AN APPLICATION INVOLVING SERIOUS RISK TO LIFE OR PROPERTY WITHOUT ENSURING THAT THE SYSTEM AS A WHOLE HAS BEEN DESIGNED TO ADDRESS THE RISKS, AND THAT THE OMRON PRODUCT(S) IS PROPERLY RATED AND INSTALLED FOR THE INTENDED USE WITHIN THE OVERALL EQUIPMENT OR SYSTEM.

2. Programmable Products

Omron Companies shall not be responsible for the user's programming of a programmable Product, or any consequence thereof.

Disclaimers

1. Performance Data

Data presented in Omron Company websites, catalogs and other materials is provided as a guide for the user in determining suitability and does not constitute a warranty. It may represent the result of Omron's test conditions, and the user must correlate it to actual application requirements. Actual performance is subject to the Omron's Warranty and Limitations of Liability.

2. Change in Specifications

Product specifications and accessories may be changed at any time based on improvements and other reasons. It is our practice to change part numbers when published ratings or features are changed, or when significant construction changes are made. However, some specifications of the Product may be changed without any notice. When in doubt, special part numbers may be assigned to fix or establish key specifications for your application. Please consult with your Omron's representative at any time to confirm actual specifications of purchased Product.

3. Errors and Omissions

Information presented by Omron Companies has been checked and is believed to be accurate; however, no responsibility is assumed for clerical, typographical or proofreading errors or omissions.

Precautions for Safe Use

Observe the following precautions to ensure safe use of the Product.

1. Installation and Storage Environment

- Do not install the Product near any equipment that generates a large amount of heat (such as heaters, transformers, and large-capacity resistors).
- If multiple Reader/Writers are installed near each other, communications performance may decrease due to mutual interference. Refer to *Mutual Interference of Reader/Writers* in *Reader/Writer Installation Precautions* in *Section 11 Appendices* and check to make sure there is no mutual interference between Reader/Writers.

2. Installation and Removal

- Never use an AC power supply. Doing so may result in rupture.
- Wire the Product correctly. Incorrect wiring may result in rupture or burning.
- Connect the Ethernet Cable to a host device (e.g., Switching Hub or PLC) that supports STP and ground the host device to 100 Ω or less.
- The communications range is adversely affected if there is any metal material around the RF Tag.
- Transmission will not be possible if the front and back panels are mistakenly reversed and the Unit is mounted to a metallic surface.
V680-D1KP66MT
V680S-D2KF67M/-D8KF67M
V680S-D2KF68M/-D8KF68M
- The transmission distance will be reduced when the Unit is not mounted to a metallic surface.
V680-D1KP66MT
V680S-D2KF67M/-D8KF67M
V680S-D2KF68M/-D8KF68M
- The maximum communications range can be obtained when the Antenna faces the RF tag directly. When the RF tag is installed at a tilt, the communications range is reduced. Consider the effect of the RF tag at tilt when installing the RF Tag.
- Provide the mounting distances between plural RF tags to prevent them from malfunctions due to mutual interference.
- if the central axis of an antenna and RF tag shifts, a communications range will fall.
- Do not touch the product immediately after usage at high temperatures, Doing so may occasionally result in burning.

3. Application Methods

- Do not bend the Cable to a bending radius of 40 mm or less. Doing so may break the wires.
- If an error is detected in the Product, immediately stop operation and turn OFF the power supply. Consult with an OMRON representative.

4. Cleaning

- Do not clean the Product with paint thinner, benzene, acetone, or kerosene.

5. Disposal

- Dispose of the Product as industrial waste.

Precautions for Correct Use

Always observe the following precautions to prevent operation failures, malfunctions, and adverse effects on performance and equipment.

1. Installation and Storage Environment

Do not use or store the Product in the following locations.

- Locations subject to combustible gases, explosive gases, corrosive gases, dust, dirt, metal powder, or salt
- Locations where the specified ambient temperature range or ambient humidity range is exceeded
- Locations subject to extreme temperature changes that may result in condensation
- Locations subject to direct vibration or shock outside the specified ranges

2. Installation

- This Product uses a frequency band of 13.56 MHz to communicate with RF Tags. Some transceivers, motors, inverters, switch-mode power supplies, and other devices generate electrical noise that will affect these communications. If any of these devices are located in the vicinity of the Product, they may affect communications with RF Tags, and may possibly damage the RF Tags. Prior to using the Product in the vicinity of any of these devices, perform a test to determine whether the Product can be used under the resulting influence.
- Connect the control signal to the positive and negative sides of the power supply.
The control signal is used to change the operation mode of the Reader/Writer.

Refer to *Connector* in *Section 3 Names and Functions of Components* for the connection methods.



- Do not exceed the rated voltage range. Doing so may result in Product destruction or burning.
- Tighten the mounting screws to a torque of 1.2 N·m.
- Tighten the Cable connector to a torque of 0.39 to 0.49 N·m.
- Mount the two-way Branch Cable with an M4 screw.

3. Application Methods

- Do not drop the Product.
- Do not pull on the Cables with excessive force.
- Do not attempt to disassemble, repair, or modify the Product.
- If you use the products in an environment that will subject them to oil, confirm that the oil that is used will not adversely affect the resins used in the products.

4. Maintenance

- Perform inspections both daily and periodically.

Refer to *Maintenance and Inspection* in *Section 10 Maintenance and Inspection* for the items to inspect.

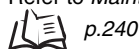

Meanings of Symbols



CHECK!

Indicates particularly important points related to a function, including precautions and application advice.



Indicates page numbers containing relevant information.



Indicates reference to helpful information and explanations for difficult terminology.

Table of Contents

Introduction	1
Terms and Conditions Agreement	2
Precautions for Safe Use	4
Precautions for Correct Use	5
Meanings of Symbols	6
Table of Contents	7
Section 1 Product Overview	13
Features	14
Application Flowchart	18
Product Specifications	25
Reader/Writer	25
Connector Cover (Slim Type)	29
RF Tag	30
Data Characteristics	42
Communications Range Specifications	42
Section 2 System Configuration	51
System Configuration	52
Section 3 Names and Functions of Components	57
Component Names	58
Reader/Writer	58
RF Tag	62
Section 4 Installation and Connections	65
Installation	66
Reader/Writer	66
Connector Cover	69
RF Tag	71

Connections and Wiring	78
Connecting and Removing the Reader/Writer Power Cable and Ethernet Cable	78
Section 5 Preparations for Communications	81
Starting the Reader/Writer	82
Reader/Writer Starting Procedure	82
Setting Communications Conditions	83
Preparations for Work	83
Setting the IP Address of the Reader/Writer from a Web Browser	85
Setting the IP Address of the Reader/Writer on the Network Configurator	87
Setting Tag Data Links	90
Section 6 Functions	91
Operation Mode	92
Run Mode	92
Safe Mode	92
RF Tag Communications	93
Communications Options	93
Normal RF Tag Communications	98
Tag Memory Management	98
Reader/Writer Controls	100
RESET	100
Maintenance	101
Reading Device Information	101
Noise Measurement	101
Setting Functions	102
Initialization	102
Setting Communications Conditions	103
Network Settings	105
Error Logs	106
System Error Log	106
Command Error Log	106
Web Server	107
Status Monitoring, Setting, and Confirmation	107
Convenient Functions	107

RFID System Maintenance	108
Communication Diagnostic	108
RF Analyzer	111
Multi-Reader/Writer Operation	113
Field Extension Mode	115
High-speed Traveling Mode	116
Using Communication Diagnostic and the RF Analyzer	118
Using the Web Server	118
Using Multi-Reader/Writer Operation	124
Using Field Extension Mode	124
Using High-speed Traveling Mode	135
Section 7 Host Communications Specifications	145
EtherNet/IP Communications Protocol	146
Data Exchange with Ethernet/IP	146
EtherNet/IP Communications with the Reader/Writer	147
Tag Data Link Setting Methods	148
Memory Assignments	150
V680S Commands	152
V680S Command Details	156
READ ID	156
READ DATA	157
WRITE DATA	158
LOCK	159
DATA FILL	160
RF TAG OVERWRITE COUNT CONTROL	161
RESTORE DATA	162
COPY DATA	163
INITIALIZE	165
SET RF TAG COMMUNICATIONS	166
GET RF TAG COMMUNICATIONS SETTINGS	167
SET MULTI-READER/WRITER OPERATION	168
GET MULTI-READER/WRITER SETTINGS	170
GET MODEL INFORMATION	172
GET FIRMWARE VERSION	173
GET OPERATING TIME	174
MEASURE NOISE	175

GET COMMAND ERROR LOG	176
GET RESTORE INFORMATION	178
GET MULTI-READER/WRITER STATUS	180
RESET	181
Time Charts	182
Time Charts	182

Section 8 Browser Interface 187

Browser Operation Window	188
Operation Interface	190
Password Entry View	190
Status View	191
Network Settings View	192
Communications Settings View	193
SET MULTI-READER/WRITER OPERATION	194
RF Tag Communications View	195
Log View	196
Noise Monitor View	197
RF Analyzer	198
Reboot	202
Configuration	203
Configuration File	208

Section 9 Troubleshooting 211

Error Descriptions	212
Fatal Errors	212
Nonfatal Errors	213
Errors and Indicator Status	214
Fatal Errors	214
Nonfatal Errors	216
Tag Data Link Error	216
Errors and Countermeasures	217
Reader/Writer Operation Errors	217
IP Address Duplication Error	218
System Errors	218
V680S Command Errors	220
RF Tag Communications Errors	221

Troubleshooting Flowcharts	222
Main Check Flowchart	222
System Connections Check Flowchart	223
Operating Conditions and External Environment Check Flowchart	224
Host Device Communications Check Flowchart	225
RF Tag Communications Check Flow	226
About The Ethernet Communication Abnormality	227
Cannot Display the Web Browser Operation Window	228
Problem	228
Solution	229
Java installation	230
Java Security Settings	231
Java Security Settings Are Not Displayed	233
Register Trusted Site	234
Countermeasures for Other Problems	235
Safe Mode	237
Starting in Safe Mode	237
Section 10 Maintenance and Inspection	239
Maintenance and Inspection	240
Section 11 Appendices	241
Data Characteristics	242
RF Tag Communications Range (for Reference Only)	242
RF Tag Communications Time (for Reference Only)	250
Reader/Writer Installation Precautions	254
V680S-HMD63-EIP	254
V680S-HMD64-EIP	255
V680S-HMD66-EIP	257
RF Tag Installation Precautions	259
V680-D1KP54T	259
V680-D1KP66T	262
V680-D1KP66MT	265
V680-D1KP66T-SP	268
V680-D1KP58HTN	272
V680S-D2KF67	274

V680S-D2KF67M	277
V680S-D8KF67	280
V680S-D8KF67M	283
V680S-D2KF68	286
V680S-D2KF68M	289
V680S-D8KF68	292
V680S-D8KF68M	295
RF Tag Memory Capacities and Memory Types	298
RF Tag Memory Map	299
Chemical Resistance of the Reader/Writers and RF Tags	302
Degree of Protection	306
Differences in Address and Size Specifications between V680 and V680S Reader/Writers	308

Index	309
-------	-----

Revision History	312
------------------	-----

Firmware Version Update History	313
---------------------------------	-----

Section 1

Product Overview

☒ Features	14
☒ Application Flowchart	18
☒ Product Specifications	25
Reader/Writer	25
Connector Cover (Slim Type)	29
RF Tag	30
☒ Data Characteristics	42
Communications Range Specifications	42

Features

The integrated V680S-series Reader/Writers (V680S-HMD6□-EIP) perform communications with RF Tags according to commands from a host device.

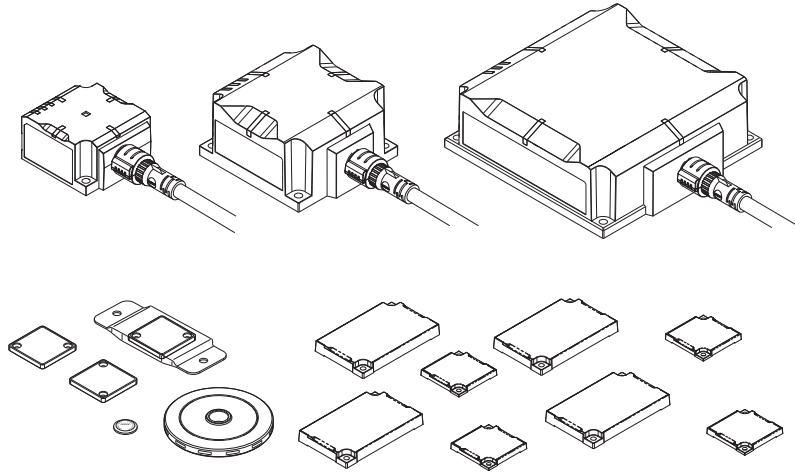

■ Integrated Structure

The controller, amplifier, and antenna are integrated into the Reader/Writer for a simple structure.

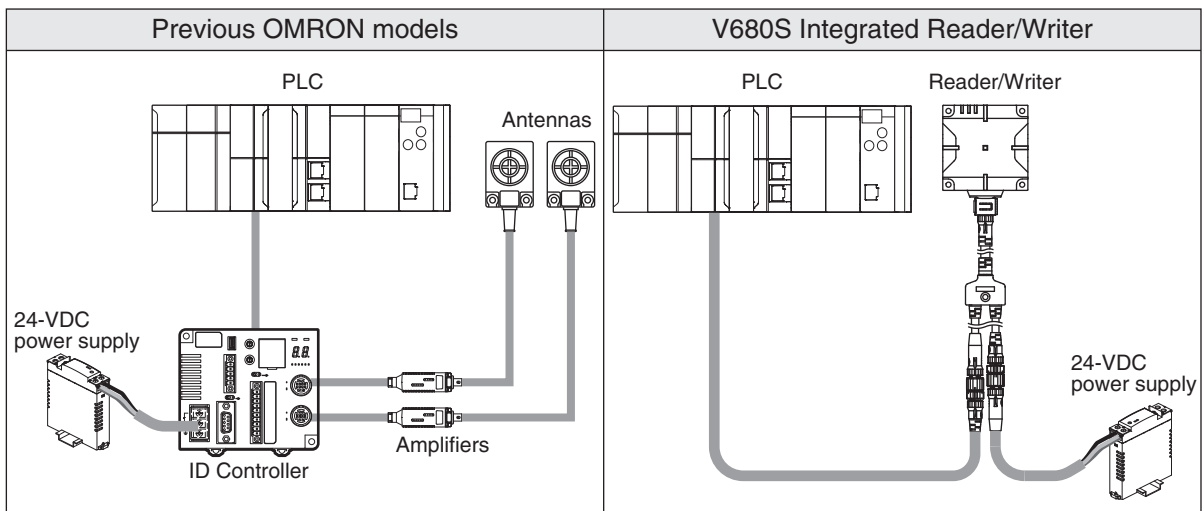

■ Simple Installation

The Reader/Writer is automatically set to the best parameters according to the RF Tags to achieve stable communications with more consistent communications and less omissions of RF Tags in the communications field.

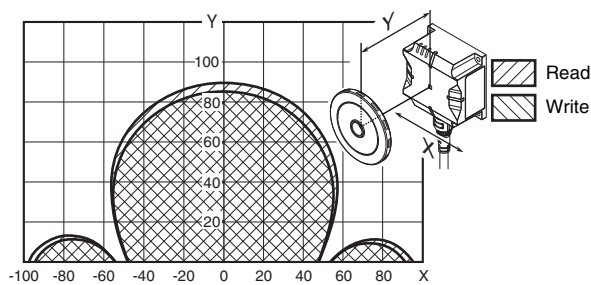

■ Stable Operation

When the Reader/Writer communicates with an RF Tag, it diagnoses the communications leeway and reports the result. You can check the communications leeway to appropriately install the Reader/Writer and RF Tags to achieve stable operation of your OMRON RFID System.

For details, refer to *Using Communication Diagnostic and the RF Analyzer* in *Section 6 Functions*.

 p.118

If you use the RFID System under installation conditions that provide a high communications leeway, you can reduce communications troubles during system operation and achieve stable line operation.

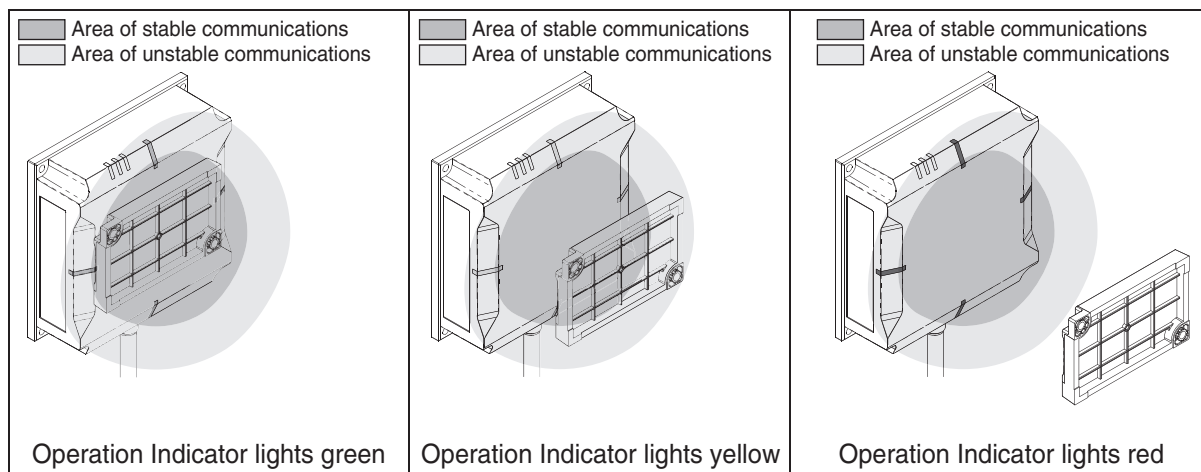

Simple Connection with EtherNet/IP

The Reader/Writer communicates with the host device through EtherNet/IP. EtherNet/IP is an industrial multi-vendor network that uses Ethernet. The EtherNet/IP specifications are open standards managed by the ODVA (Open DeviceNet Vendor Association). EtherNet/IP is used by a wide range of industrial devices.

Because EtherNet/IP uses standard Ethernet technology, various general-purpose Ethernet devices can be used in the network. You can easily increase the number of Reader/Writers by using a Switching Hub.

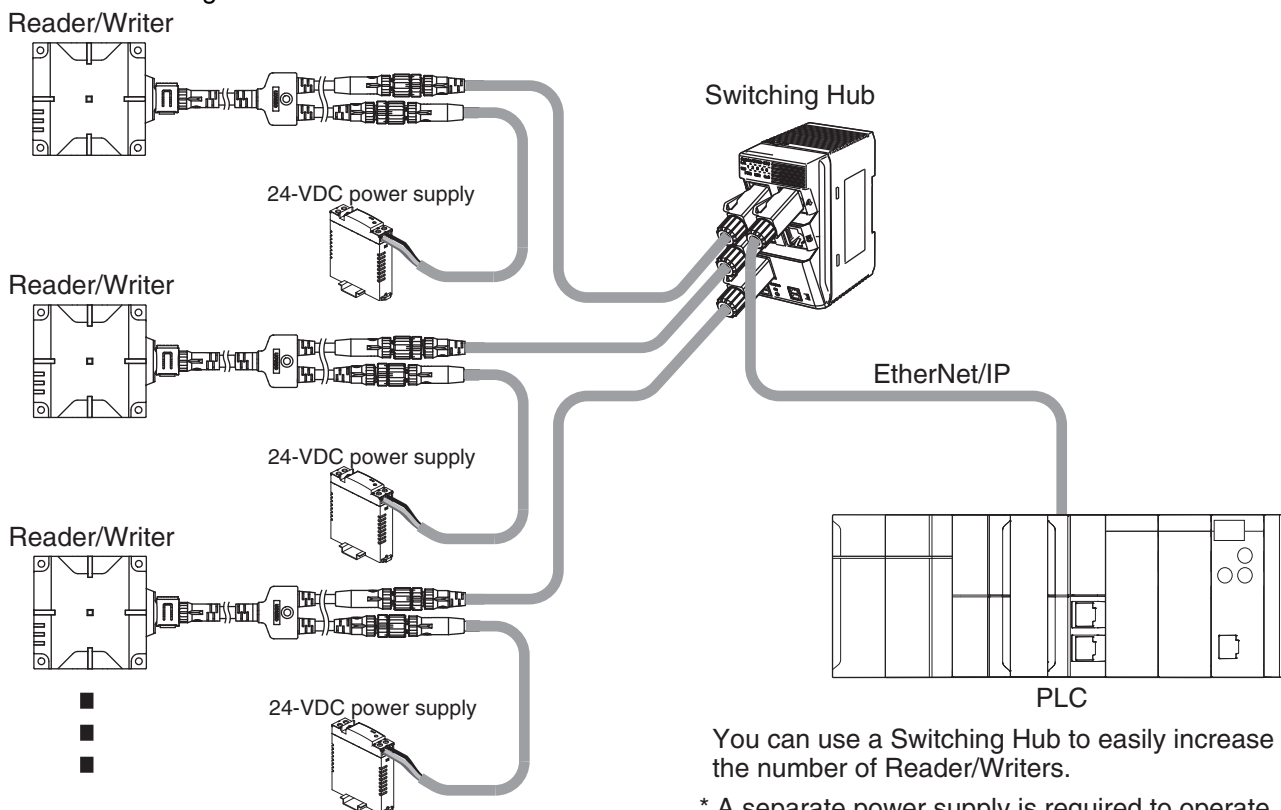

You can use a Switching Hub to easily increase the number of Reader/Writers.

* A separate power supply is required to operate the Reader/Writers.



To connect more than one Reader/Writer, all devices must be set to a unique IP address.

CHECK!

EtherNet/IP has mainly the following features.

High-speed, High-capacity Data Exchange through Tag Data Links (Cyclic Communications)

The EtherNet/IP protocol supports implicit communications, which allows cyclic communications called tag data links with EtherNet/IP devices.

Tag Data Links (Cyclic Communications) at a Specified Communications Cycle for Each Application Regardless of the Number of Nodes

Tag data links (cyclic communications) operate at the cyclic period that is specified for each application, regardless of the number of nodes. Data is exchanged over the network at the refresh cycle that is set for each connection. The communications refresh cycle will not increase even if the number of nodes is increased, i.e., the concurrency of the connection's data is maintained.

Because the refresh cycle can be set for each connection, each application can communicate at its ideal refresh cycle. For example, interprocess interlocks can be transferred at high speed, while the production commands and the status information are transferred at low speed.

■ Easy Operation

A Web server is provided so that you can easily perform setup and status monitoring by connecting to a computer, without the need for any special software.

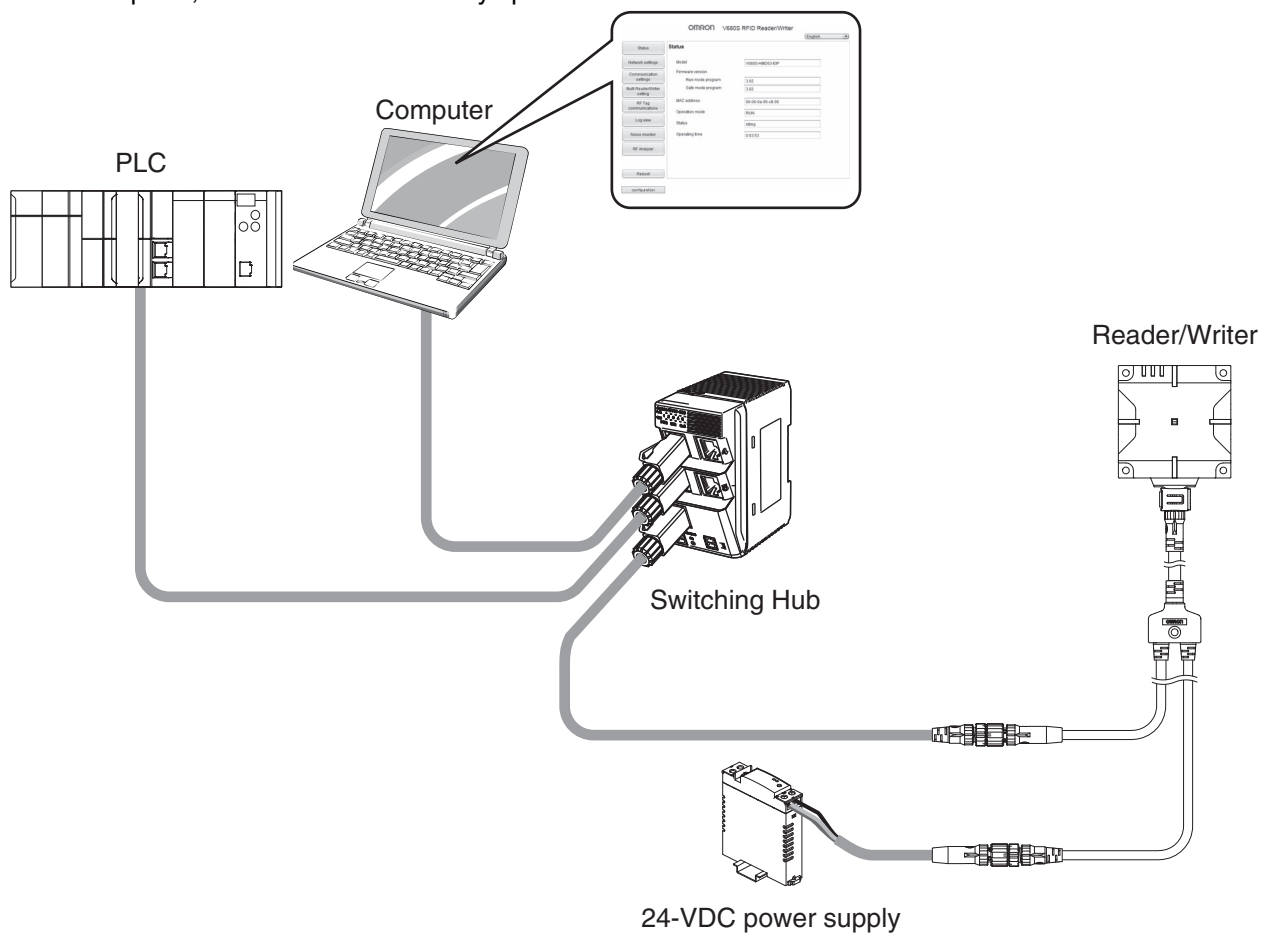

You can connect a computer to the Switching Hub to easily set up the Reader/Writers and check the status of the Reader/Writers.

Application Flowchart

A simple application flowchart is described below. For correct application methods and details, refer to the reference page or section given for each step.

Preparations

Checking the Installation Environment

 p.254



CHECK!

Refer to *Reader/Writer Installation Precautions* in *Section 11 Appendices* to confirm the conditions under which the RFID System will not be influenced by surrounding metal on the Reader/Writer or mutual interference between Reader/Writers.

Installation

 p.66

Install the Reader/Writer with four M4 screws.

V680S-HMD63-EIP: Use two screws.

V680S-HMD64-EIP/-HMD66-EIP: Use four screws.

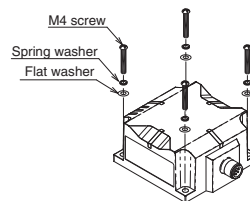

Connections and Wiring

 p.78

Insert the Power Cable into the power supply connector on the Reader/Writer (M12 A-Coding, female) and turn the cable connector on the Reader/Writer end clockwise to lock it in place.

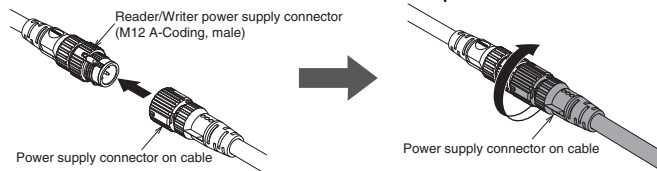

Insert the Ethernet Cable into the Ethernet connector on the Reader/Writer (M12 D-Coding, male) and turn the cable connector on the Reader/Writer end clockwise to lock it in place.

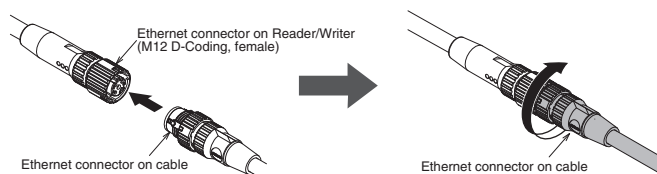

Mount the Branch Cable with one M4 screw.
Recommended tightening torque: 0.39 to 0.49 N·m

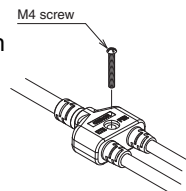

Connect the Power Cable to a 24-VDC power supply.

Connect the Ethernet Cable to the host device (PLC) or Switching Hub.

 **Setting Reader/Writer Communications Conditions**
p.83

The default network settings for the Reader/Writer are listed in the following table.

IP address	192.168.1.200 (fixed settings)
Subnet mask	255.255.255.0
Default gateway	192.168.1.254
Port number for Web browser	7090

Change the network settings of the host device to match those of the Reader/Writer.

Host Device Setting Example

IP address: 192.168.1.100
Subnet mask: 255.255.255.0



 **Communications Test with Host Device**
p.188

Start a web browser (e.g., Internet Explorer) on the host computer, enter **http://192.168.1.200/** in the address box, and press the Enter Key. Communications will be possible if the following view appears.

OMRON V680S RFID Reader/Writer English

<ul style="list-style-type: none"> Status Network settings Communication settings Multi Reader/Writer setting RF Tag communications Log view Noise monitor RF Analyzer Reboot configuration 	<p>Status</p> <p>Model: V680S-HMD/63-EIP</p> <p>Firmware version</p> <p>Run mode program: 3.02</p> <p>Safe mode program: 3.02</p> <p>MAC address: 00-00-0a-95-c8-06</p> <p>Operation mode: RUN</p> <p>Status: Idling</p> <p>Operating time: 0:03:53</p>
---	--

Using Communication Diagnostic to Check Communications Leeway

 p.118

1. Connect the Ethernet cable, turn ON the power supply to the Reader/Writer, and then start a Web browser on a computer.
2. Specify the IP address of the Reader/Writer in the address field of the web browser. Enter **http://192.168.1.200/** if you are using the default IP address.

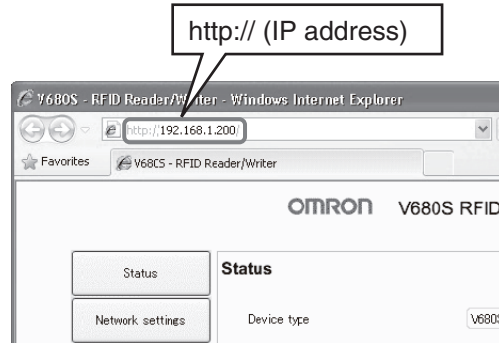

3. The Communications Setting View will be displayed.

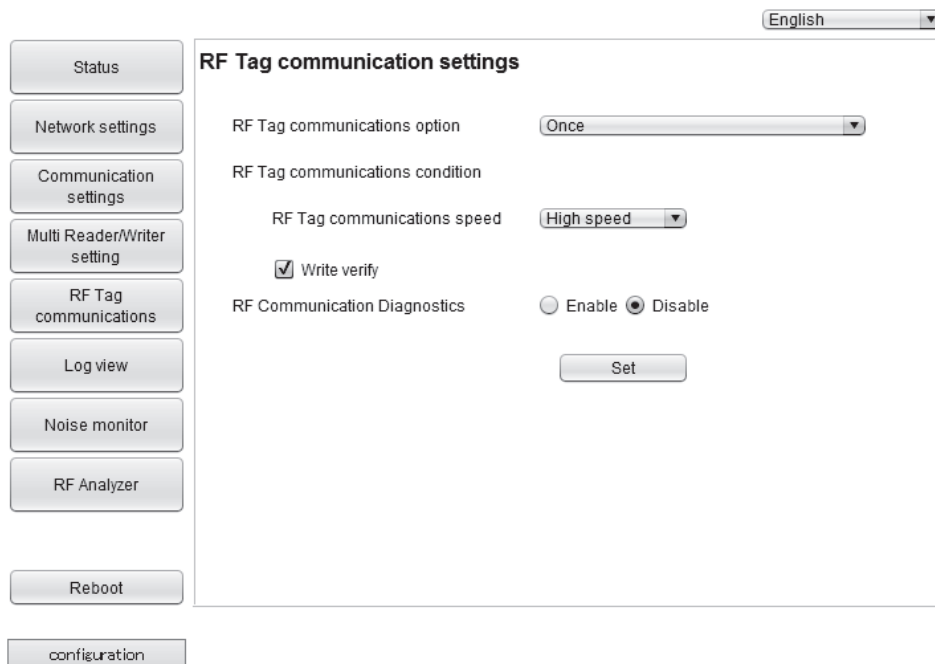

Using the RF Analyzer to Check the Results of Communication Diagnostic

p.122

1. Display the RF Analyzer View.

No	Time	Command	Result	Diagnostic description	Details
1	0:19:29	Read Data	Stable		
2	0:19:36	Read Data	Warning	The Signal Level is low. Push the "Display" button on the right, and follow the instruction.	Display
3	0:19:41	Read Data	Warning	The Signal Level is low. Push the "Display" button on the right, and follow the instruction.	Display
4	0:19:47	Read Data	Error	RF Tag missing error. Check the RF tag are located in front of the Reader/Writer.	
5	0:19:50	Read Data	Error	RF Tag missing error. Check the RF tag are located in front of the Reader/Writer.	
6	0:19:53	Read Data	Error	RF Tag missing error. Check the RF tag are located in front of the Reader/Writer.	

2. Click the **Show** Button in the Details column and follow the guidance to check the probable causes and corrections.

OMRON V680S RFID Reader/Writer

The Signal Level is low.

Follow the instruction in below.

There is a possibility the positioning and posture of the Reader/Writer and the RF tag is not proper.

Make a position so that the Reader/Writer and the RF tag surface in face to face, then execute the RF communication diagnostics.

The inclination of the RF tag surface to the Reader/Writer may cause the deterioration of RF communication.

© Copyright OMRON Corporation 2013. All Rights Reserved.

3. In this example, the position of the Tag is corrected according to the guidance.

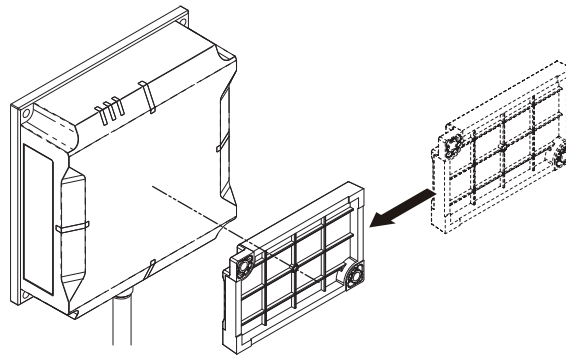

4. You can check the graph display to check quantitative information on the degree of instability.

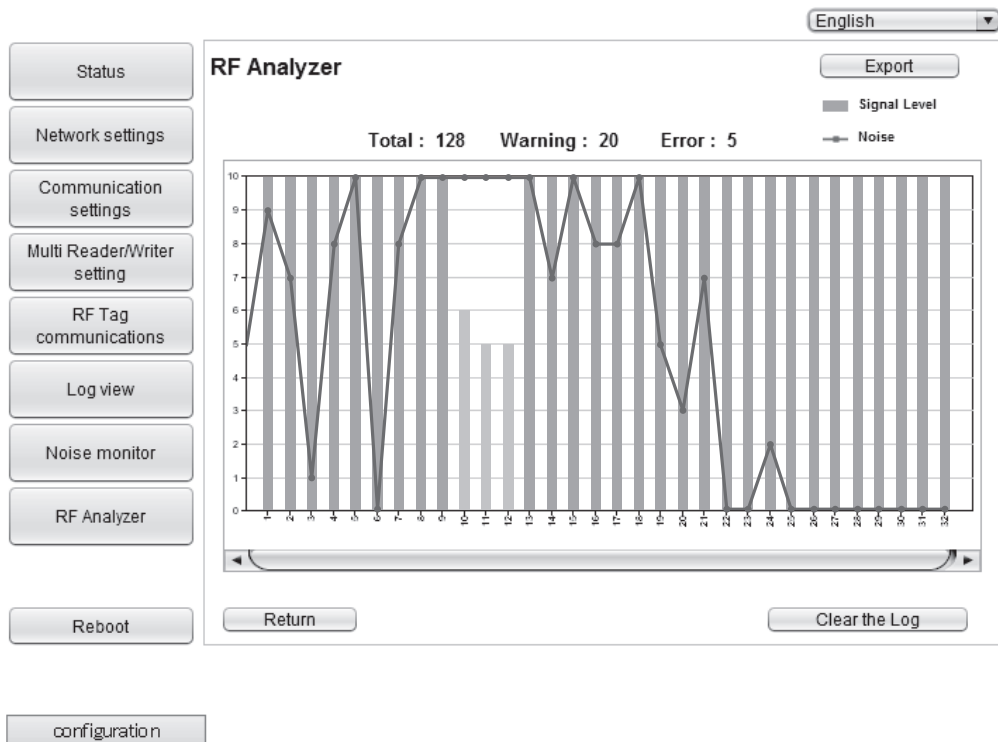

When you are finished, perform the step to communicate with the RF Tag again and check to see if stable communications have been achieved.

Communications with RF Tags for Commands from the Host Device Using Tag Data Links
 p.152

The Reader/Writer can perform various types of communications with RF Tags.

Communications command name	Description	Page
READ DATA	Reads data from an RF Tag in the communications field.	p.157
WRITE DATA	Writes data to an RF Tag in the communications field.	p.158
READ ID	Reads the ID code from an RF Tag in the communications field.	p.156
COPY DATA	Uses two Reader/Writers to copy data from the memory of an RF Tag in the communications field of one Reader/Writer (A) to the memory of the RF Tag in the communications field of another Reader/Writer (B).	p.163
DATA FILL	Writes the specified data to the specified number of words beginning from the specified start address. The specifications are made in the command.	p.160
LOCK	This command locks the specified memory in the RF Tag. It will no longer be possible to write data to the locked memory. The lock cannot be released.	p.159
RF TAG OVERWRITE COUNT CONTROL	Used to manage the number of times data is written to an RF Tag. You can use this command for RF Tags with EEPROM memory.	p.161
RESTORE DATA	This command reads the restore information from the Reader/Writer.	p.162

If you Encounter a Problem...

 Troubleshooting

 p.153 Error Codes

 p.60 Operation Indicators

 p.222 Troubleshooting Flowcharts

Product Specifications

Reader/Writer

General Specifications

Item	Model	V680S-HMD63-EIP	V680S-HMD64-EIP	V680S-HMD66-EIP
Compliance standards		ISO/IEC 18000-3 (15693)		
Frequency		13.56 MHz		
Dimensions		50 × 50 × 30 mm (W × H × D, excluding protruding parts and cables)	75 × 75 × 40 mm (W × H × D, excluding protruding parts and cables)	120 × 120 × 40 mm (W × H × D, excluding protruding parts and cables)
Power supply voltage		24 VDC (-15% to +10%)		
Consumption current		0.2A max.		
Ambient operating temperature		-10 to 55°C (with no icing)		
Ambient operating humidity		25% to 85% (with no condensation)		
Ambient storage temperature		-25 to 70°C (with no icing)		
Ambient storage humidity		25% to 85% (with no condensation)		
Insulation resistance		20 MΩ min. (at 500 VDC) between cable terminals and case		
Dielectric strength		1,000 VAC, 50/60 Hz for 1 min between cable terminals and case		
Vibration resistance		No abnormality after application of 10 to 500 Hz, 1.5-mm double amplitude, acceleration: 100 m/s ² , 10 sweeps in each of 3 axis directions (up/down, left/right, and forward/backward) for 11 minutes each		
Shock resistance		No abnormality after application of 500 m/s ² , 3 times each in 6 directions (Total: 18 times)		
Degree of protection		IP67 (IEC 60529:2001) Oil resistance equivalent to IP67F (JIS C 0920:2003, Appendix 1) <small>See Note 1</small>		
Materials		Case: PBT resin, Filled resin: Urethane resin		
Mass		Approx. 240 g	Approx. 390 g	Approx. 760 g
Installation method		Reader/Writer body: Two M4 screws (Use a screw of 12 mm or more in length.) Cable branching section: One M4 screw	Four M4 screws Use a screw of 12mm or more in length.	
Host communications interface		Ethernet 10BASE-T/100BASE-TX		
Host device communications protocol		EtherNet/IP		
Accessories		Instruction Sheet Copy of EC Self Declaration IP address label		

Note 1. Oil resistance has been tested using a specific oil as defined in the OMRON test method.

■ Dimensions

■ V680S-HMD63-EIP

(Unit: mm)

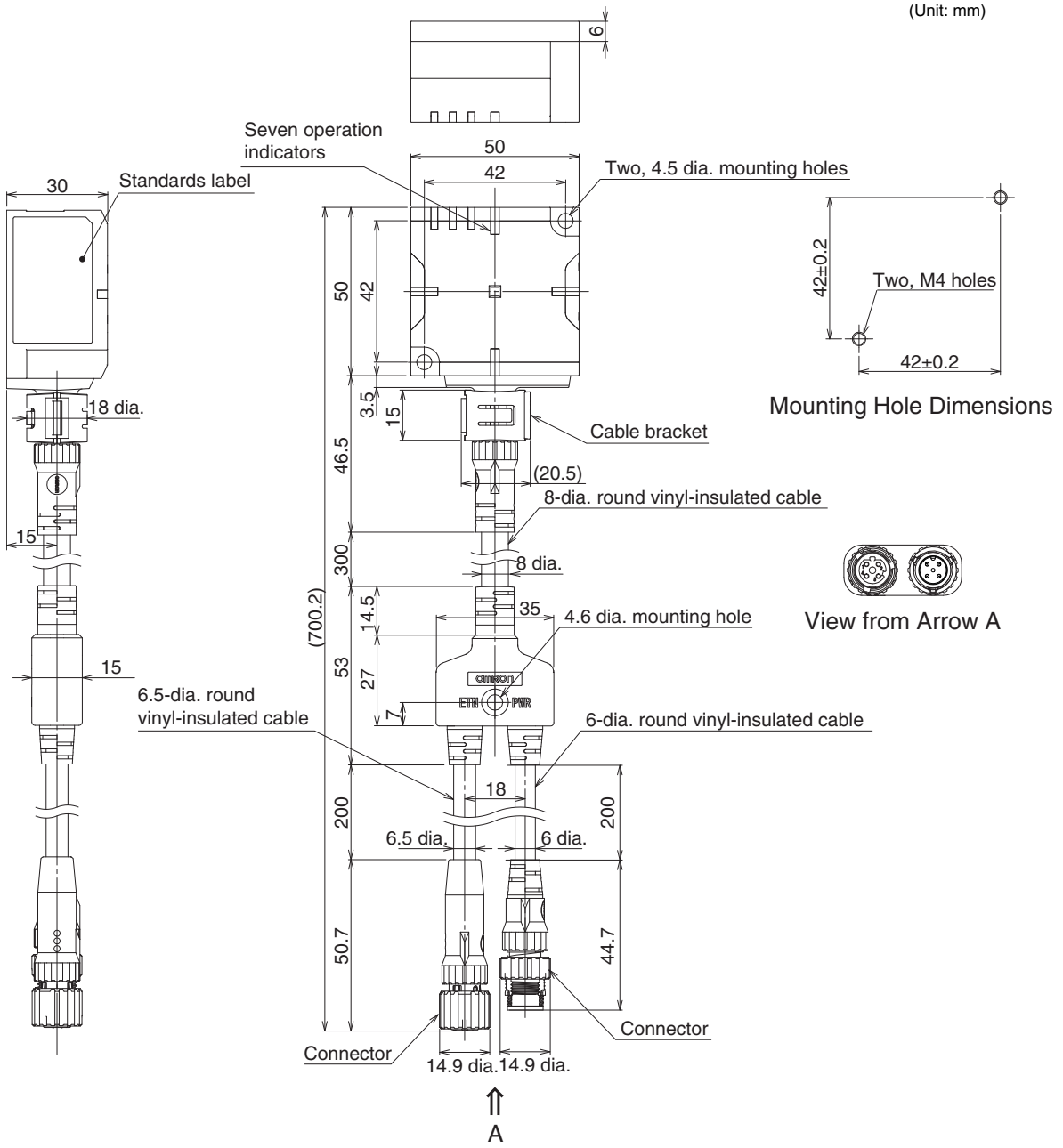

■ V680S-HMD64-EIP

(Unit: mm)

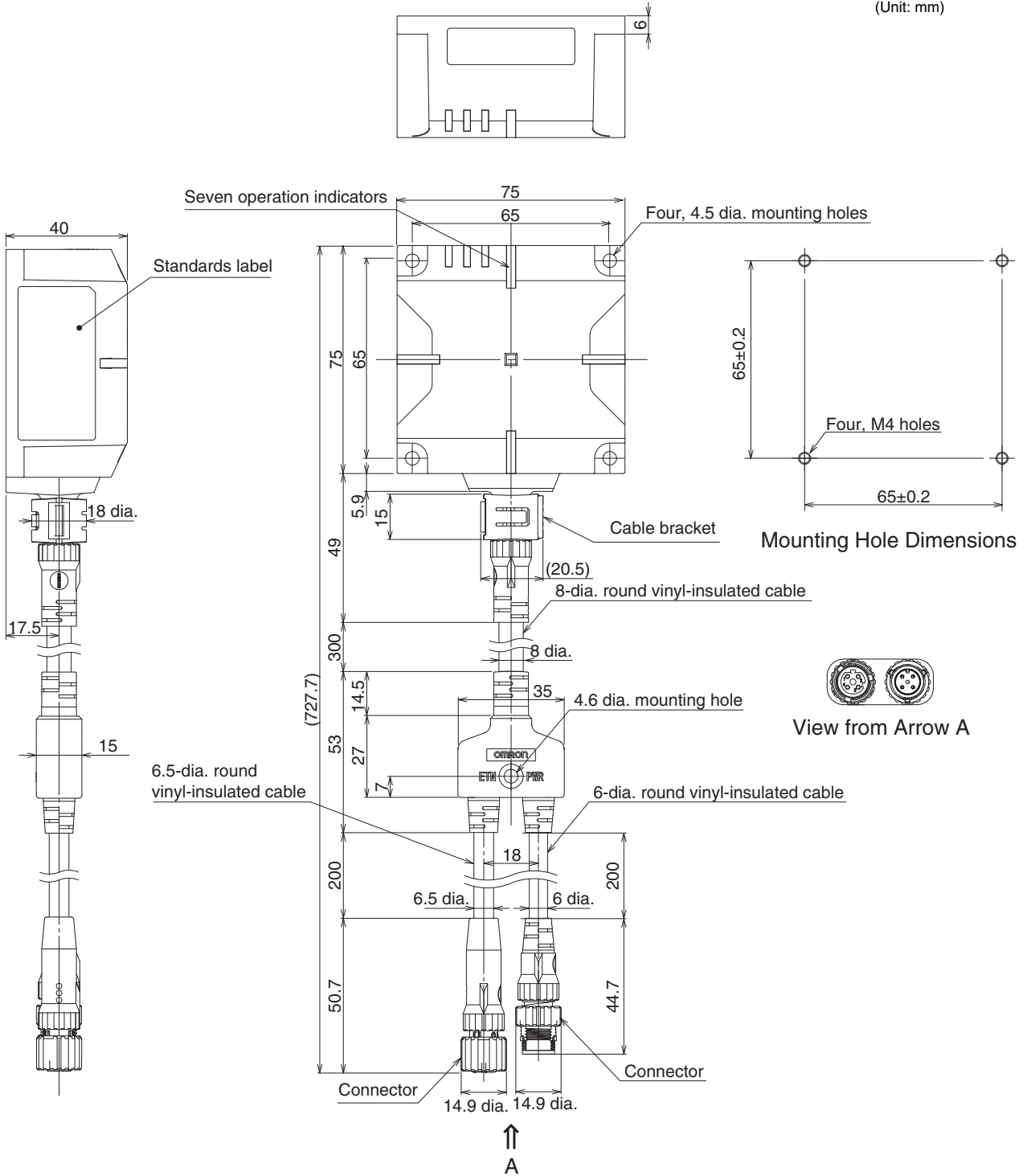

▪ V680S-HMD66-EIP

(Unit: mm)

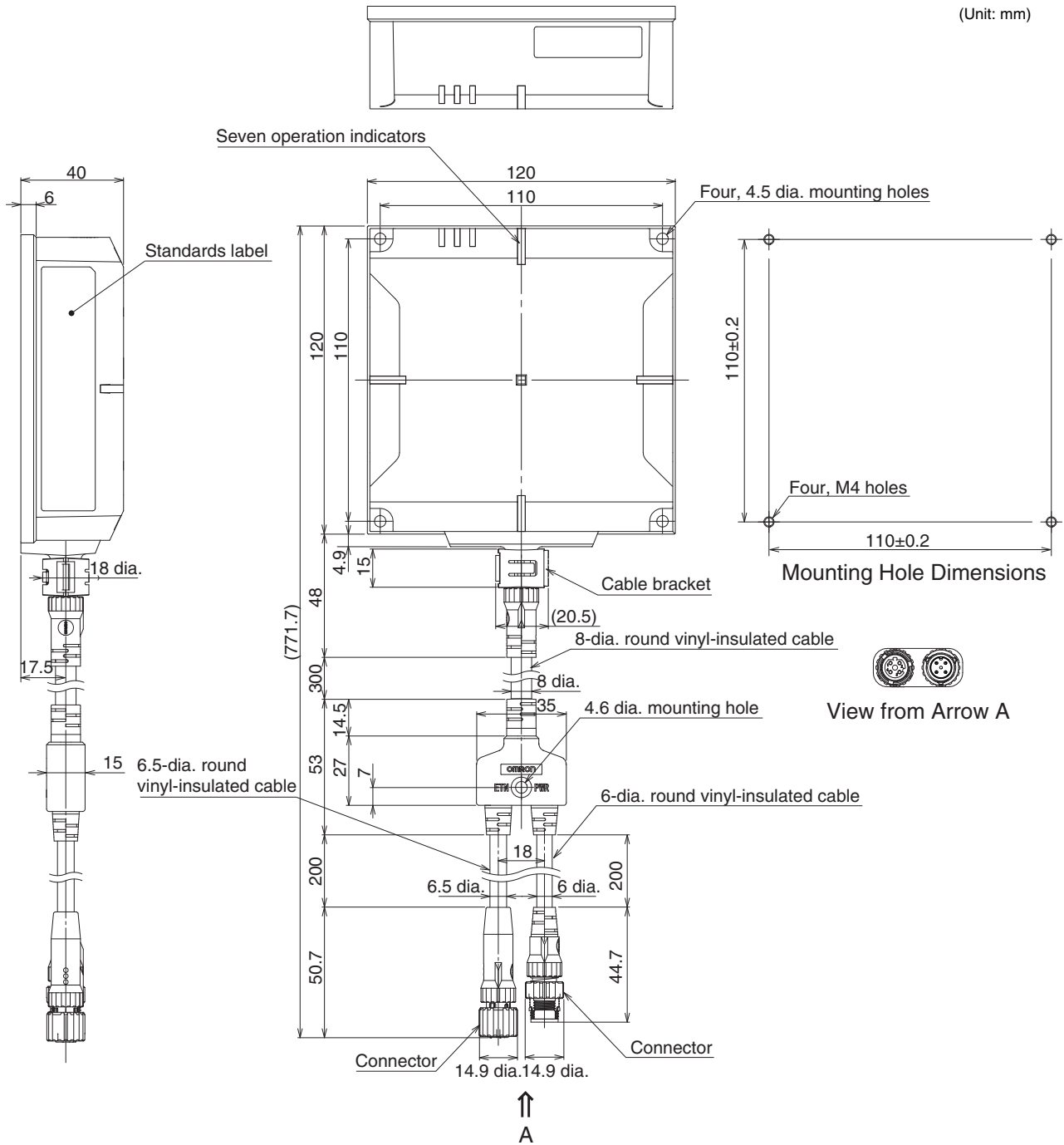

Connector Cover (Slim Type)

General Specifications

Item	Model	V680S-A63-S	V680S-A64-S
Ambient operating temperature		-10 to 55°C (with no icing)	
Ambient operating humidity		25% to 85% (with no condensation)	
Ambient storage temperature		-25 to 70°C (with no icing)	
Ambient storage humidity		25% to 85% (with no condensation)	
Materials		PBT resin	
Installation method		Fixing screws in two locations*1	

*1. In addition to the reader/writer mounting holes, two mounting holes are required for the connector cover.

Dimensions

V680S-A63-S

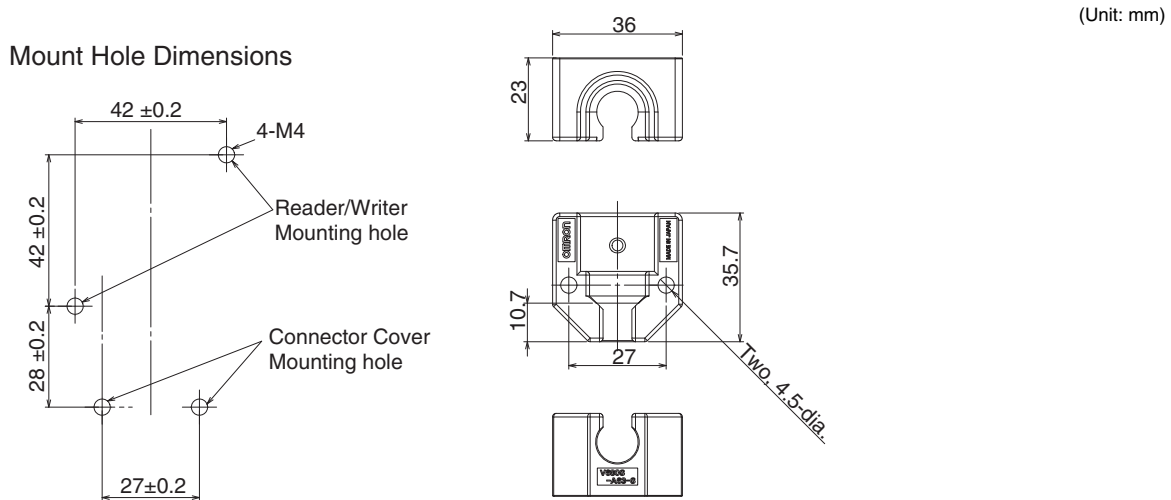

V680S-A64

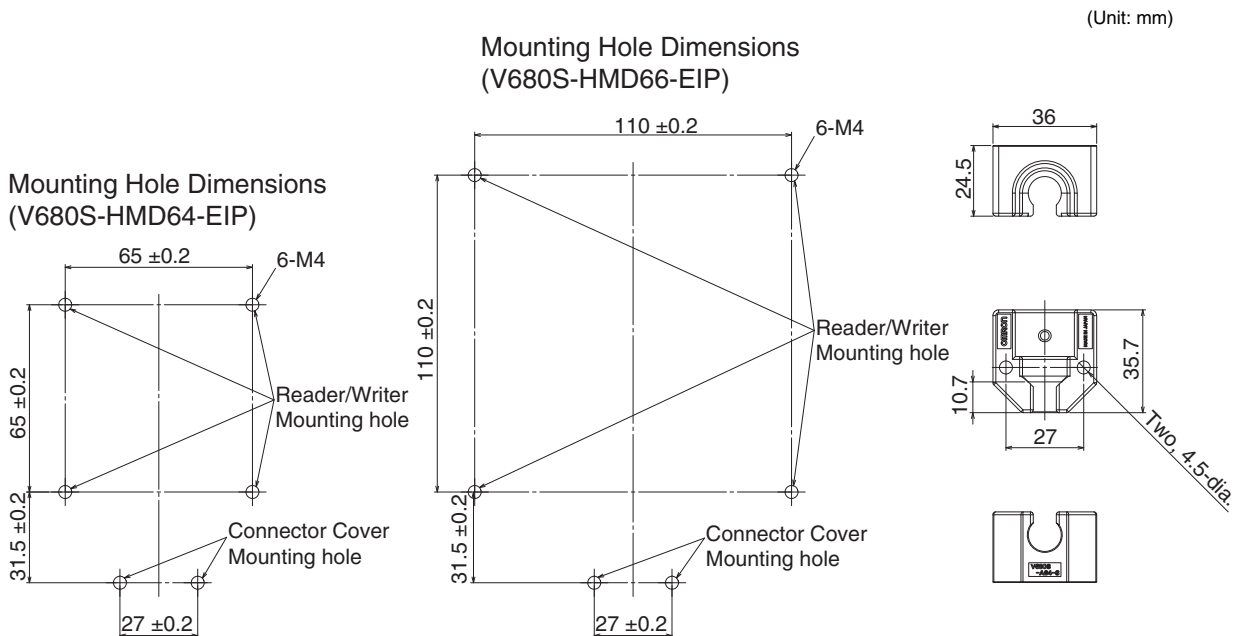

RF Tag

■ V680-D1KP54T

■ General Specifications

Item	Model	V680-D1KP54T
Compliance standards		ISO/IEC 18000-3 (15693)
Memory capacity		1,000 bytes (user area)
Memory type		EEPROM
Data retention		10 years after writing (85°C or less), 0.5 years after writing (85 to 125°C) Total data retention at high temperatures exceeding 125°C is 10 hours <i>See Note 1.</i>
Write endurance		100,000 writes for each block (25°C)
Ambient operating temperature		-25 to 85°C (with no icing)
Ambient operating humidity		35% to 95%
Ambient storage temperature		-40 to 125°C (with no icing)
Ambient storage humidity		35% to 95%
Degree of protection		IP67 (IEC 60529:2001) Oil resistance equivalent to IP67G (JIS C 0920:2003, Appendix 1) <i>See Note 2.</i>
Vibration resistance		No abnormality after application of 10 to 2,000 Hz, 1.5-mm double amplitude, acceleration: 150 m/s ² , 10 sweeps each in X, Y, and Z directions for 15 minutes each
Shock resistance		No abnormality after application of 500 m/s ² , 3 times each in X, Y, and Z directions (Total: 18 times)
Dimensions		20 dia. × 2.7 mm
Materials		PPS resin
Weight		Approx. 2 g
Metal countermeasures		None

Note 1. After storing RF Tags at high temperatures, rewrite the data even if changes are not required. High temperatures are those between 125 and 180°C.

2. Oil resistance has been tested using a specific oil as defined in the OMRON test method.

■ Dimensions

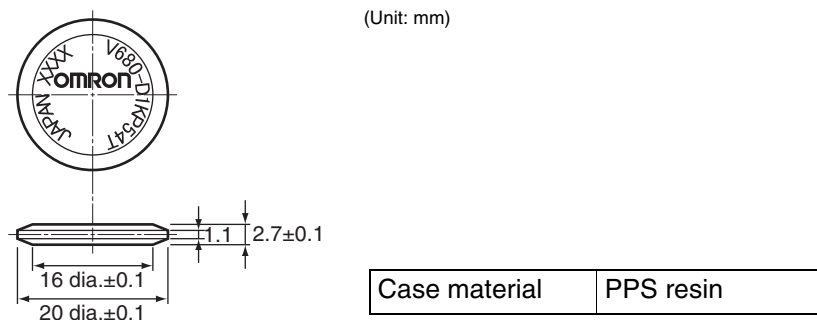

The V680-D1KP54T RF Tag can be placed in the Attachment in either direction. The direction does not affect operation.



The ID code is written in the memory of the RF Tag and may be affected by data retention characteristics at high temperatures. Take suitable precautions when using the READ ID command for RF Tags operating at high temperatures.



You cannot use FIFO Repeat communications.

V700-A80 Attachment

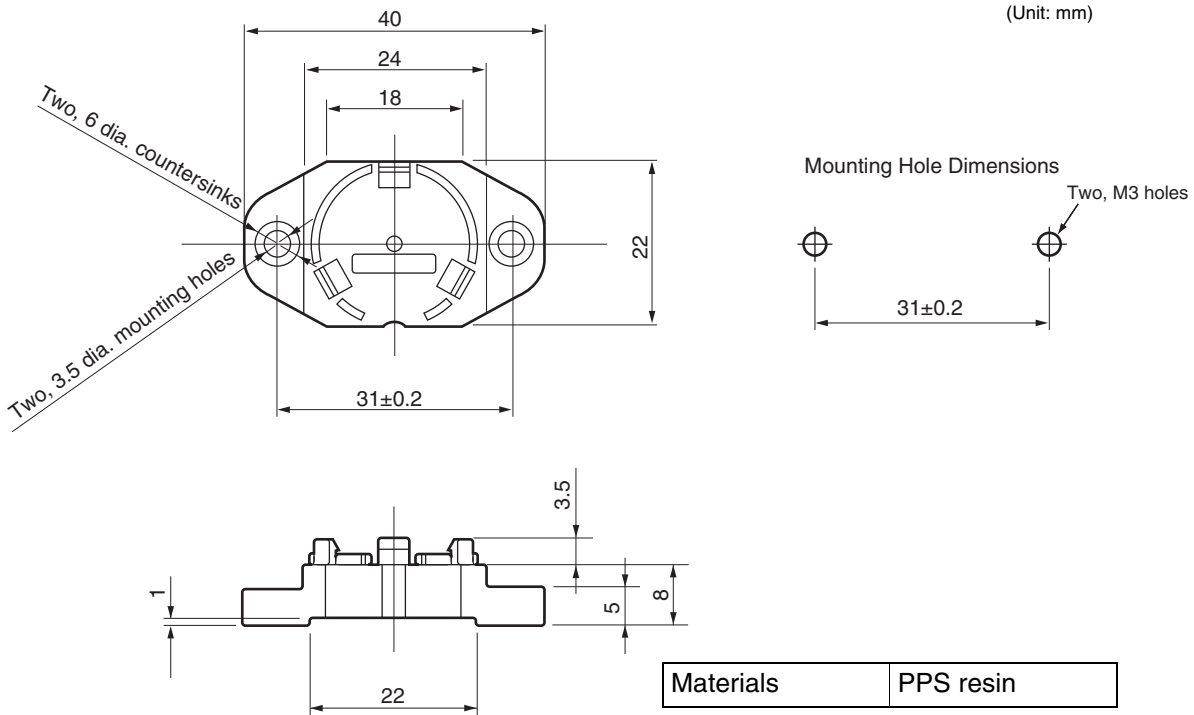

▪ **RF Tag Heat Resistance**

- Storing RF Tags under high temperatures or under heat cycles will adversely affect the performance of the internal parts and the service life of the RF Tags.

An LTPD of 10% was used for evaluation of RF Tags that reached the end of their service life after testing under the following test conditions.

- Heat cycle:
- 1,000 cycles of 30 minutes each between -10 and 150°C. No failures occurred in 22 samples.
 - 200 cycles of 30 minutes each between -10 and 180°C. No failures occurred in 22 samples.
- High-temperature storage:
- 1,000 hours at 150°C. No failures occurred in 22 samples.
 - 200 hours at 180°C. No failures occurred in 22 samples.



LTPD: Lot Tolerance Percent Defective

The lower limit of the malfunction rate for lots to be considered unacceptable during reliability testing.

■ V680-D1KP66T/-D1KP66MT

■ General Specifications

Item	Model	V680-D1KP66T	V680-D1KP66MT
Compliance standards		ISO/IEC 18000-3 (15693)	
Memory capacity		1,000 bytes (user area)	
Memory type		EEPROM	
Data retention		10 years after writing (85°C or less), 0.5 years after writing (85 to 125°C) Total data retention at high temperatures exceeding 125°C is 10 hours <small>See Note 1.</small>	
Write endurance		100,000 writes for each block (25°C)	
Ambient operating temperature		-25 to 85°C (with no icing)	
Ambient operating humidity		35% to 95%	
Ambient storage temperature		-40 to 125°C (with no icing)	
Ambient storage humidity		35% to 95%	
Degree of protection		IP68 (IEC 60529:2001) Oil resistance equivalent to IP67G (JIS C 0920:2003, Appendix 1) <small>See Note 2.</small>	
Vibration resistance		No abnormality after application of 10 to 2,000 Hz, 1.5-mm double amplitude, acceleration: 150 m/s ² , 10 sweeps each in X, Y, and Z directions for 15 minutes each	
Shock resistance		No abnormality after application of 500 m/s ² , 3 times each in X, Y, and Z directions (Total: 18 times)	
Dimensions		34 × 34 × 3.5 mm (W × H × D)	
Materials		PPS resin	
Weight		Approx. 6 g	Approx. 7.5 g
Metal countermeasures		None	Provided

Note 1. After storing RF Tags at high temperatures, rewrite the data even if changes are not required. High temperatures are those between 125 and 180°C.

2. Oil resistance has been tested using a specific oil as defined in the OMRON test method.

The V680-D1KP66MT must be mounted on a metallic surface. The markings on the V680-D1KP66T and V680-D1KP66MT are shown below.

● V680-D1KP66MT



● V680-D1KP66T



The marked surface is the communications surface. When mounting the RF Tag, face the marked surface toward the Reader/Writer.



The ID code is written in the memory of the RF Tag and may be affected by data retention characteristics at high temperatures. Take suitable precautions when using the READ ID command for RF Tags operating at high temperatures.



You cannot use FIFO Repeat communications.

▪ **Dimensions**

V680-D1KP66T/-D1KP66MT

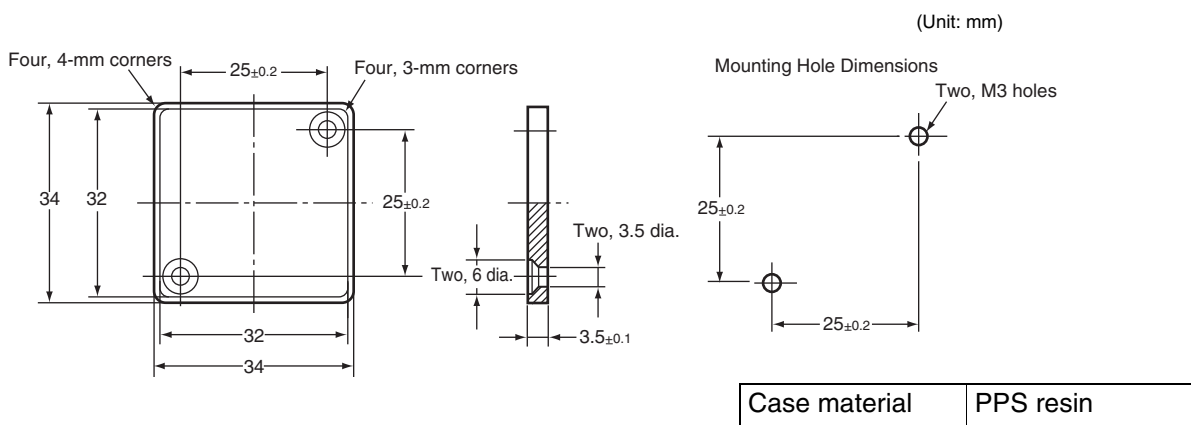

V600-A86 Attachment

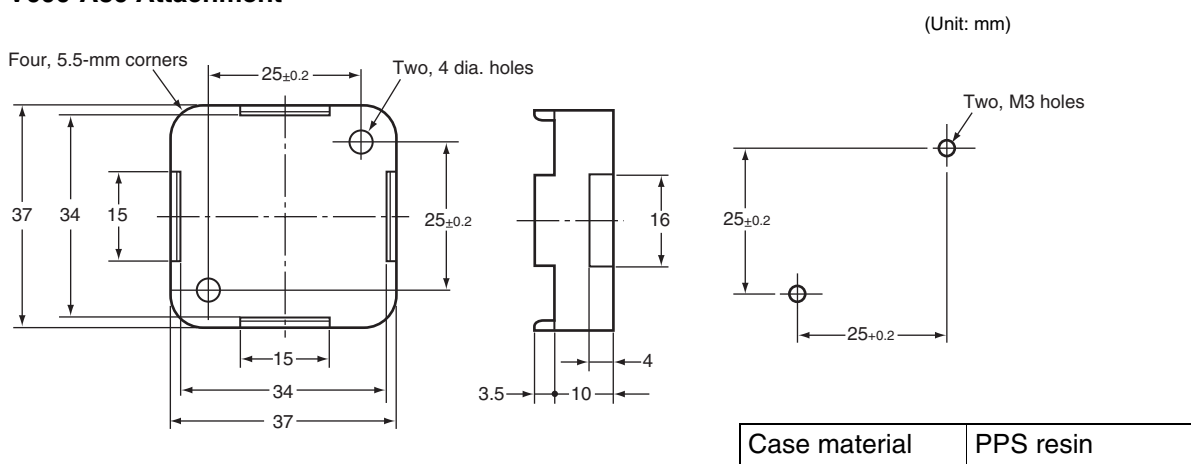

▪ **RF Tag Heat Resistance**

• Storing RF Tags under high temperatures or under heat cycles will adversely affect the performance of the internal parts and the service life of the RF Tags.

An LTPD of 10% was used for evaluation of RF Tags that reached the end of their service life after testing under the following test conditions.

- Heat cycle: 1,000 cycles of 30 minutes each between -10 and 150°C. No failures occurred in 22 samples.
200 cycles of 30 minutes each between -10 and 180°C. No failures occurred in 22 samples.
- High-temperature storage: 1,000 hours at 150°C. No failures occurred in 22 samples.
200 hours at 180°C. No failures occurred in 22 samples.



LTPD: Lot Tolerance Percent Defective

The lower limit of the malfunction rate for lots to be considered unacceptable during reliability testing.

■ V680-D1KP66T-SP

■ General Specifications

Item	Specification
Compliance standards	ISO/IEC 18000-3 (15693)
Memory capacity	1,000 bytes
Memory type	EEPROM
Data retention	10 years (85°C or less)
Write endurance	100,000 writes for each block (25°C)
Ambient operating temperature	-25 to 70°C (with no icing)
Ambient operating humidity	35% to 95% (with no condensation)
Ambient storage temperature	-40 to 110°C (with no icing)
Ambient storage humidity	35% to 95% (with no condensation)
Vibration resistance	10 to 2,000 Hz, 1.5-mm double amplitude, acceleration: 150 m/s ² , 10 sweeps each in 3 directions for 15 minutes each
Shock resistance	No abnormality after application of 500 m/s ² , 3 times each in X, Y, and Z directions (Total: 18 times)
Dimensions	95 × 36.5 × 6.5 mm (W × H × D, excluding protruding parts)
Degree of protection	IP67
Materials	Exterior: PFA fluororesin RF Tag filling: PPS resin
Weight	Approx. 20 g
Installation method	Two M5 screws
Metal countermeasures	None

■ Dimensions

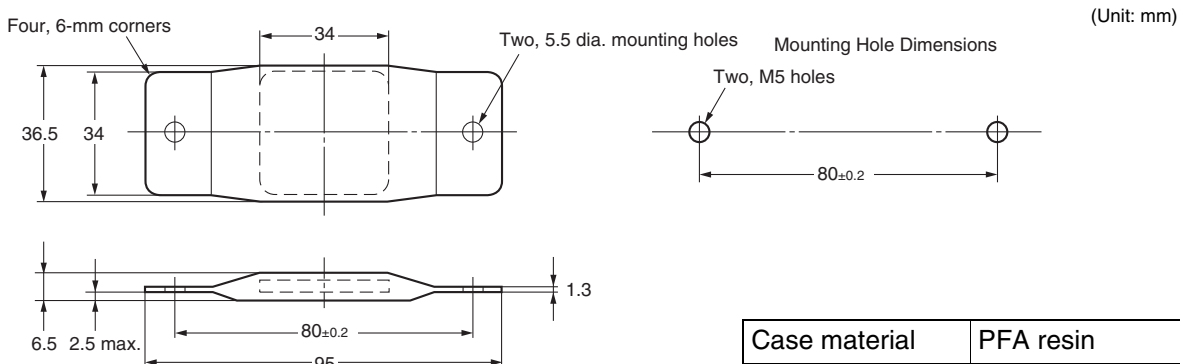

The marked surface is the communications surface. When mounting the RF Tag, face the marked surface toward the Reader/Writer.



You cannot use FIFO Repeat communications.

■ V680-D1KP58HTN

■ General Specifications

Item	Model	V680-D1KP58HTN
Compliance standards		ISO/IEC 18000-3 (15693)
Memory capacity		1,000 bytes (user area)
Memory type		EEPROM
Data retention		10 years after writing (85°C or less), 0.5 years after writing (85 to 125°C) Total data retention at high temperatures exceeding 125°C is 10 hours ^{See Note 1}
Write endurance		100,000 writes for each block (25°C)
Ambient operating temperature		-25 to 85°C (with no icing)
Ambient operating humidity		No restrictions.
Ambient storage temperature		-40 to 250°C (with no icing) (Data retention: -40 to 125°C)
Ambient storage humidity		No restrictions.
Degree of protection		IP67 (IEC 60529:2001) Oil resistance equivalent to IP67G (JIS C 0920:2003, Appendix 1) ^{See Note 2}
Vibration resistance		No abnormality after application of 10 to 2,000 Hz, 1.5-mm double amplitude, acceleration: 150 m/s ² , 10 sweeps each in X, Y, and Z directions for 15 minutes each
Shock resistance		No abnormality after application of 500 m/s ² , 3 times each in X, Y, and Z directions (Total: 18 times)
Dimensions		80 dia. × 10 mm
Materials		PPS resin
Weight		Approx. 70 g

Note 1. After storing RF Tags at high temperatures, rewrite the data even if changes are not required. High temperatures are those between 125 and 250°C.

2. Oil resistance has been tested using a specific oil as defined in the OMRON test method.

■ Dimensions

V680-D1KP58HTN

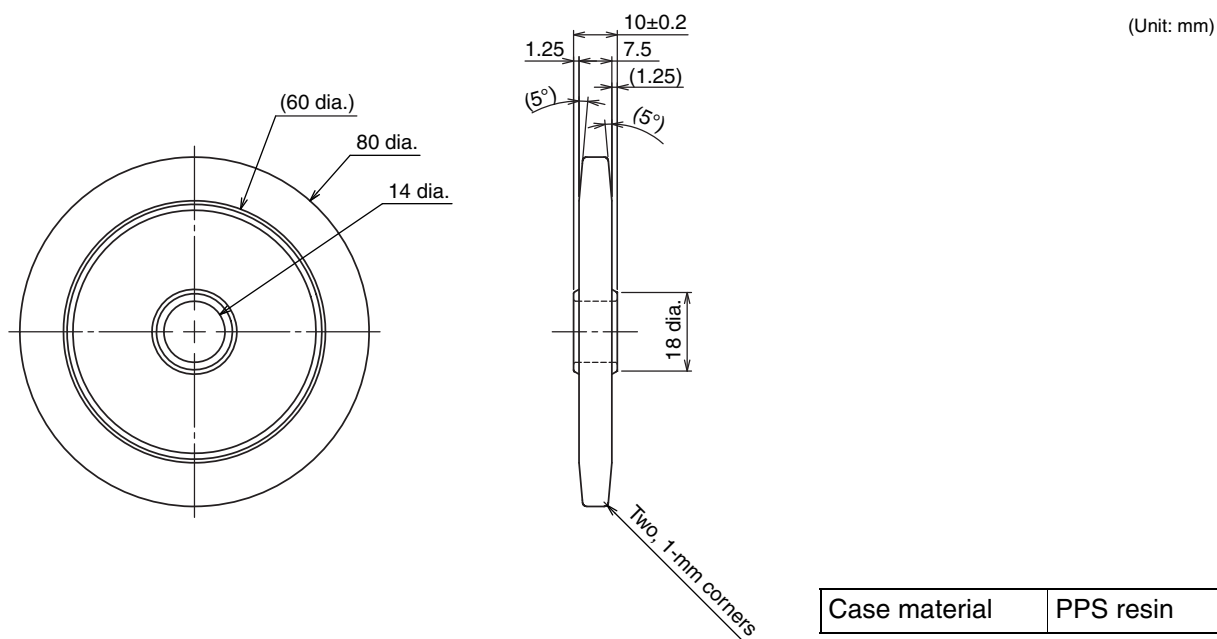

The RF Tag can be placed in the Attachment in either direction. The direction does not affect operation.

V680-A80 Attachment

This Attachment is used to hold V680-D1KP58HTN ID Tags.

Applicable model: V680-D1KP58HTN

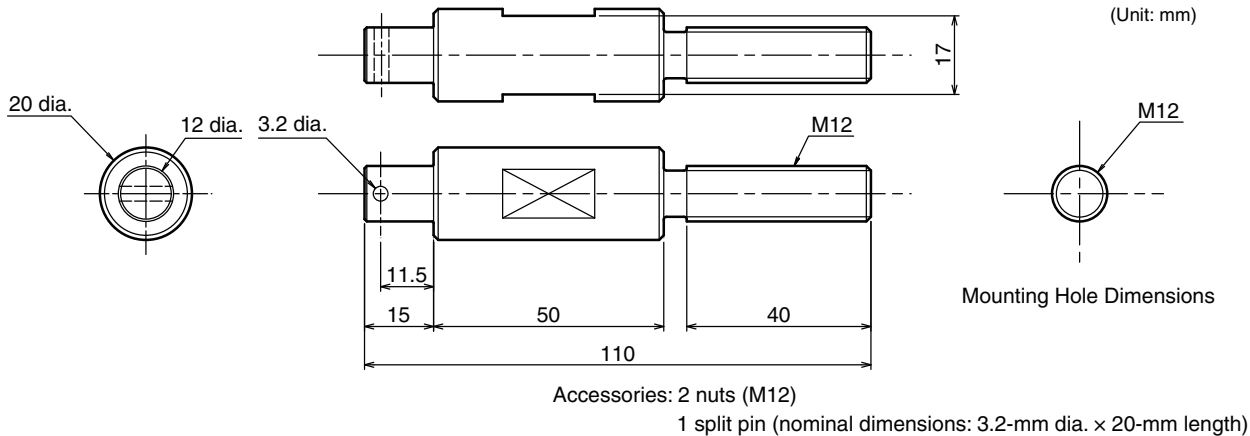

▪ **High-temperature Applications (V680-D1KP58HTN)**

▪ **Data Retention**

- Due to the characteristics of EEPROM, any data that is written to an RF Tag may be lost if it is used in a high-temperature environment that exceeds 125°C for a total of more than 10 hours. Always reset the data holding time before a total of 10 hours is reached.
- Communications between the Reader/Writer and RF Tags may fail in high-temperature environments of 85°C or higher. Do not perform communications between the Reader/Writer and RF Tag in a high-temperature environment of 85°C or higher.
- Due to the characteristics of EEPROM, the UID (RF Tag ID code) may be lost if an RF Tag is used in a high-temperature environment that exceeds 125°C. Do not use commands that use the UID in high-temperature environments that exceed 125°C.
- Do not use the ID READ command.
- You cannot use FIFO Repeat communications.

▪ **Total Usage Time**

This section gives the total time that an RF Tag can be placed at high temperatures.

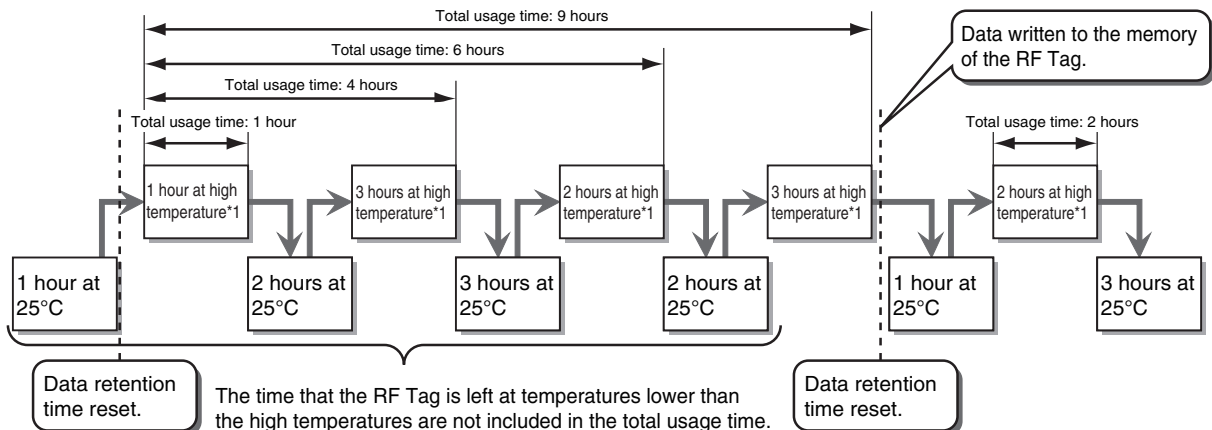

Fig. Conceptual Diagram of Resetting the Data Retention Time

*1 A “high temperature” is one between 125°C and 250°C.

▪ **Data Retention Time Reset Procedure**

Always use the following procedure to reset the data holding time before a total of 10 hours is reached.

When Using RF Tag Memory Addresses 0010 to 0015 hex

1. Read the data from RF Tag addresses 0010 to 0015 hex.

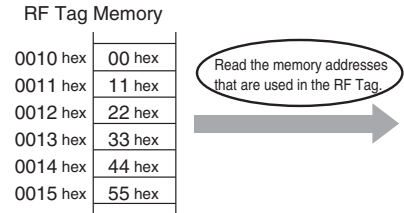

2. Write the read data to RF Tag memory addresses 0010 to 0015 hex.

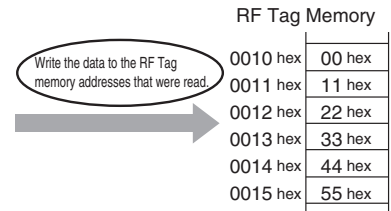

The data retention time is reset only for the RF Tag memory addresses that are written. To reset the data retention time, write the same data to all of the memory addresses that are used in the RF Tag.

▪ **Heat Resistance**

Storing RF Tags under high temperatures or under heat cycles will adversely affect the performance of the internal parts and the service life of the RF Tags.

The RF Tag were placed in the following high temperatures and then evaluated in-house. It was confirmed that no problems occurred.

- 1) 2,000 cycles of 30 minutes each between room temperature and 200°C
- 2) 500 hours at 250°C

■ V680S-D2KF67/-D2KF67M/-D8KF67/-D8KF67M

■ General Specifications

Item	Model	V680S-D2KF67	V680S-D2KF67M	V680S-D8KF67	V680S-D8KF67M
Compliance standards		ISO/IEC 18000-3 (15693)			
Memory capacity		2,000 bytes (user area)		8,192 bytes (user area)	
Memory type		FRAM			
Data retention		10 years after writing (85°C or less)			
Write Endurance		One trillion times per block (85°C or less), Access frequency ^{See Note 1.} : One trillion times			
Ambient operating temperature		-20 to 85°C (with no icing)			
Ambient operating humidity		35% to 85%			
Ambient storage temperature		-40 to 125°C (with no icing)			
Ambient storage humidity		35% to 85%			
Degree of protection		IP68 (IEC 60529:2001), Oil resistance equivalent to IP67G (JIS C 0920:2003, Appendix 1) ^{See Note 2.} IPX9K (DIN 40 050)			
Vibration resistance		No abnormality after application of 10 to 2,000 Hz, 1.5-mm double amplitude, acceleration: 150 m/s ² , 10 sweeps each in X, Y, and Z directions for 15 minutes each			
Shock resistance		No abnormality after application of 500 m/s ² , 3 times each in X, Y, and Z directions (Total: 18 times)			
Dimensions		40 × 40 × 5 mm (W × H × D)			
Materials		PPS resin			
Weight		Approx. 11.5 g	Approx. 12 g	Approx. 11.5 g	Approx. 12 g
Metal countermeasures		None	Provided	None	Provided

Note 1. The number of accesses is the total number of reads and writes.

2. Oil resistance has been tested using a specific oil as defined in the OMRON test method.

The V680S-D2KF67M/-D8KF67M must be mounted on a metallic surface. The markings on the V680-D2KF67/-D8KF67 and V680-D2KF67M/-D8KF67M are shown below.

● V680S-D2KF67M/-D8KF67M

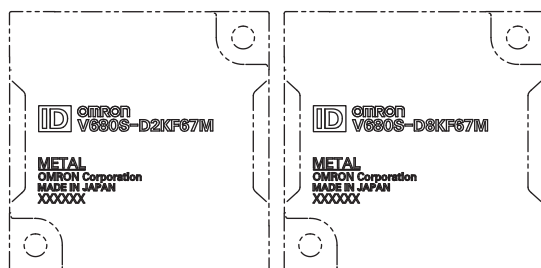

● V680S-D2KF67/-D8KF67

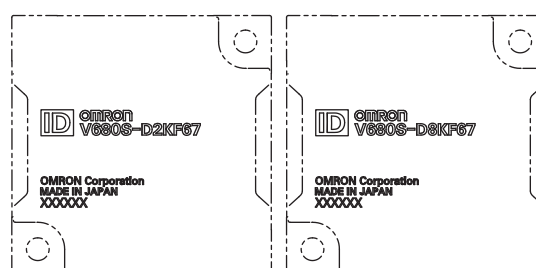

The marked surface is the communications surface. When mounting the RF Tag, face the marked surface toward the Reader/Writer.

CHECK!



You can use the V680S-D8KF67□ with Reader/Writers with firmware version 2.00 or higher.

CHECK!

▪ Dimensions

V680S-D2KF67/-D2KF67M/-D8KF67/-D8KF67M

(Unit: mm)

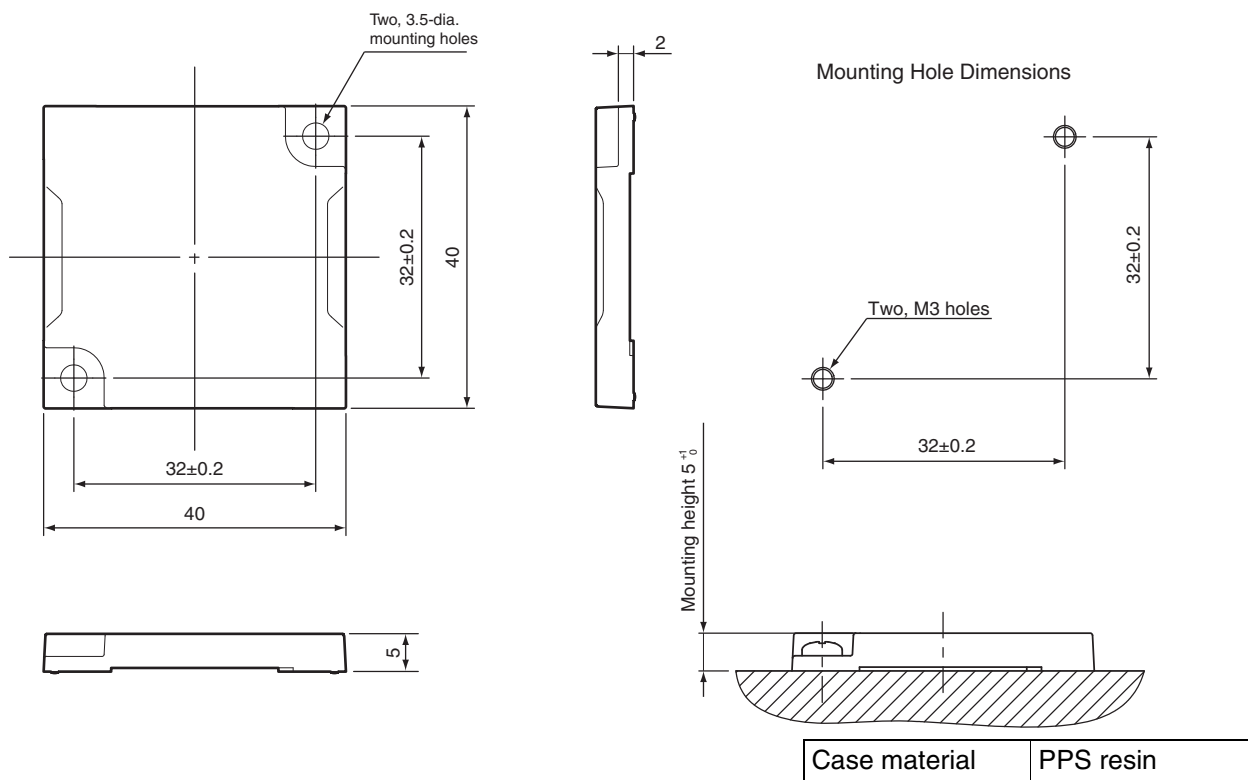

■ V680S-D2KF68/-D2KF68M/-D8KF68/-D8KF68M

■ General Specifications

Item	Model	V680S-D2KF68	V680S-D2KF68M	V680S-D8KF68	V680S-D8KF68M
Compliance standards		ISO/IEC 18000-3 (15693)			
Memory capacity		2,000 bytes (user area)		8,192 bytes (user area)	
Memory type		FRAM			
Data retention		10 years after writing (85°C or less)			
Write Endurance		One trillion times per block (85°C or less), Access frequency ^{See Note 1.} : One trillion times			
Ambient operating temperature		-20 to 85°C (with no icing)			
Ambient operating humidity		35% to 85%			
Ambient storage temperature		-40 to 125°C (with no icing)			
Ambient storage humidity		35% to 85%			
Degree of protection		IP68 (IEC 60529), Oil resistance equivalent to IP67G (JIS C 0920:2003, Appendix 1) ^{See Note 2.} IPX9K (DIN 40 050)			
Vibration resistance		No abnormality after application of 10 to 500 Hz, 1.5-mm double amplitude, acceleration: 100 m/s ² , 10 sweeps each in X, Y, and Z directions for 11 minutes each			
Shock resistance		No abnormality after application of 500 m/s ² , 3 times each in X, Y, and Z directions (Total: 18 times)			
Dimensions		86 × 54 × 10 mm (W × H × D)			
Materials		PPS resin			
Weight		Approx. 44 g	Approx. 46 g	Approx. 44 g	Approx. 46 g
Metal countermeasures		None	Provided	None	Provided

Note 1. The number of accesses is the total number of reads and writes.

2. Oil resistance has been tested using a specific oil as defined in the OMRON test method.

The V680S-D2KF68M/-D8KF68M must be mounted on a metallic surface. The markings on the V680-D2KF68/-D8KF68 and V680-D2KF68M/-D8KF68M are shown below.

● V680S-D2KF68M/-D8KF68M



● V680S-D2KF68/-D8KF68



The marked surface is the communications surface. When mounting the RF Tag, face the marked surface toward the Reader/Writer.



CHECK!

You can use the V680S-D8KF68□ with Reader/Writers with firmware version 2.00 or higher.

▪ **Dimensions**

V680S-D2KF68/-D2KF68M/-D8KF68/-D8KF68M

(Unit: mm)

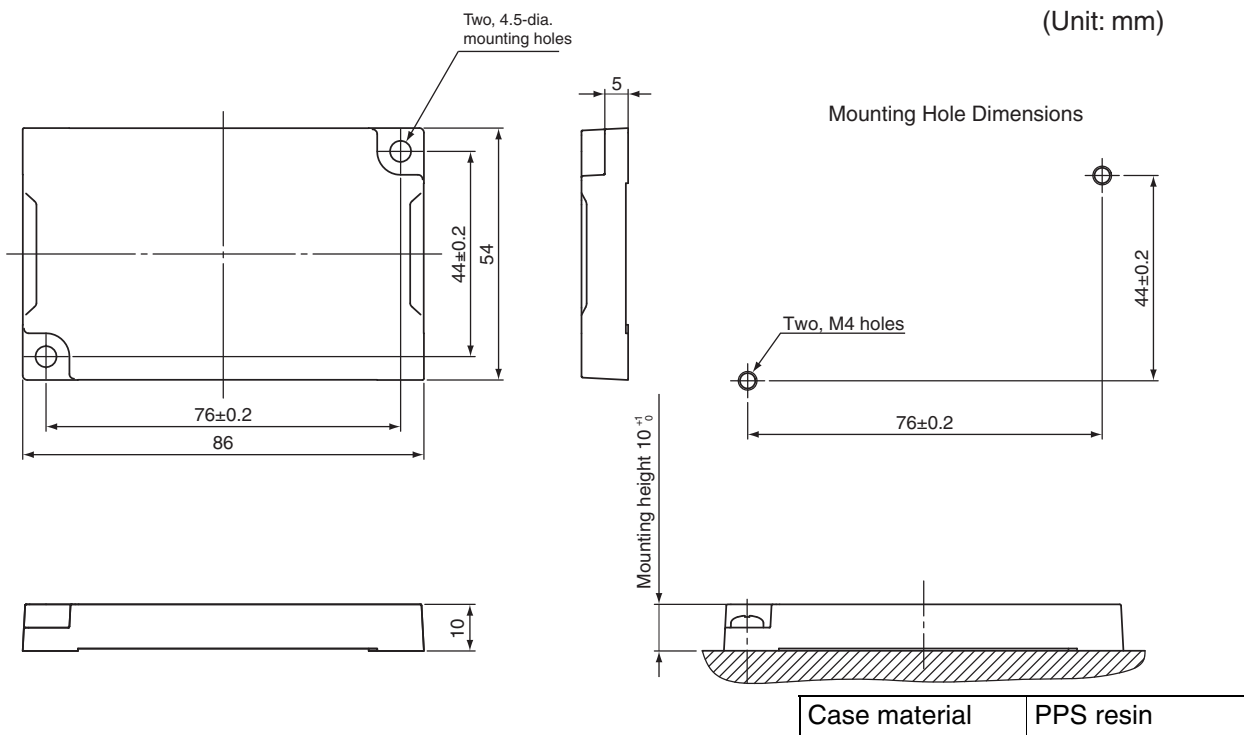

Data Characteristics

Communications Range Specifications

■ V680S-HMD63-EIP

Reader/Writer	RF Tag	Communications range specification	
V680S-HMD63-EIP (mounted to metallic material)	V680-D1KP54T (mounted to non-metallic material)	Read	0.0 to 24.0 mm (axis offset: ±10 mm)
		Write	0.0 to 20.0 mm (axis offset: ±10 mm)
	V680-D1KP66T (mounted to non-metallic material)	Read	0.0 to 30.0 mm (axis offset: ±10 mm)
		Write	0.0 to 25.0 mm (axis offset: ±10 mm)
	V680-D1KP66MT (mounted to metallic material)	Read	0.0 to 25.0 mm (axis offset: ±10 mm)
		Write	0.0 to 20.0 mm (axis offset: ±10 mm)
	V680-D1KP66T-SP (mounted to non-metallic material)	Read	0.0 to 25.0 mm (axis offset: ±10 mm)
		Write	0.0 to 20.0 mm (axis offset: ±10 mm)
	V680S-D2KF67 (mounted to non-metallic material)	Read	7.0 to 40.0 mm (axis offset: ±10 mm)
		Write	7.0 to 40.0 mm (axis offset: ±10 mm)
	V680S-D2KF67M (mounted to metallic material)	Read	6.0 to 30.0 mm (axis offset: ±10 mm)
		Write	6.0 to 30.0 mm (axis offset: ±10 mm)
	V680S-D8KF67 (mounted to non-metallic material)	Read	7.0 to 40.0 mm (axis offset: ±10 mm)
		Write	7.0 to 40.0 mm (axis offset: ±10 mm)
	V680S-D8KF67M (mounted to metallic material)	Read	6.0 to 30.0 mm (axis offset: ±10 mm)
		Write	6.0 to 30.0 mm (axis offset: ±10 mm)

Installation Conditions

● V680-D1KP54T

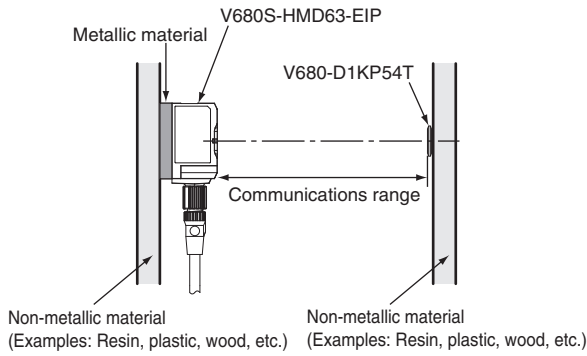

● V680-D1KP66T

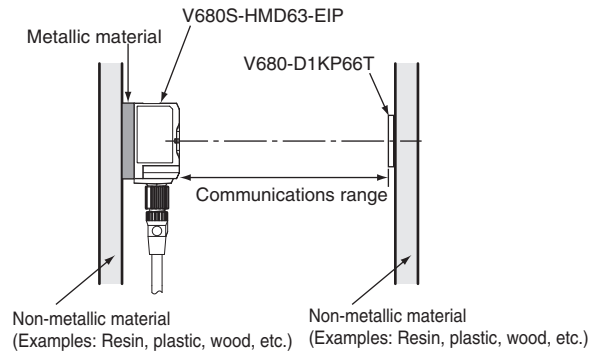

● V680-D1KP66MT

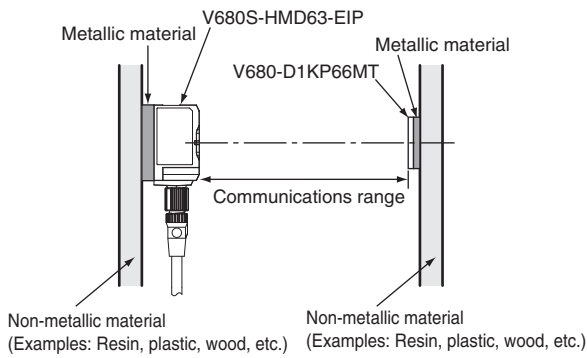

● V680-D1KP66T-SP

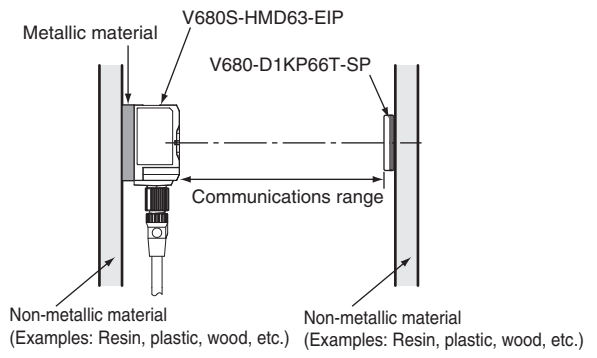

● V680S-D2KF67/-D8KF67

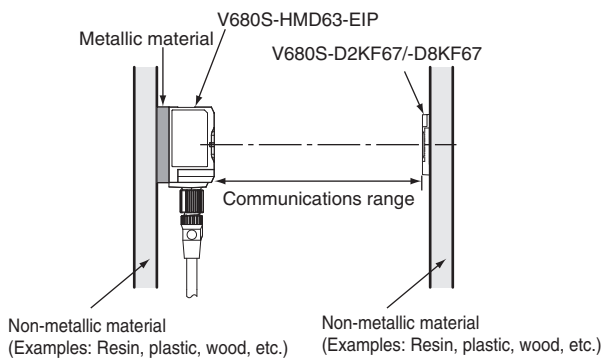

● V680S-D2KF67M/-D8KF67M

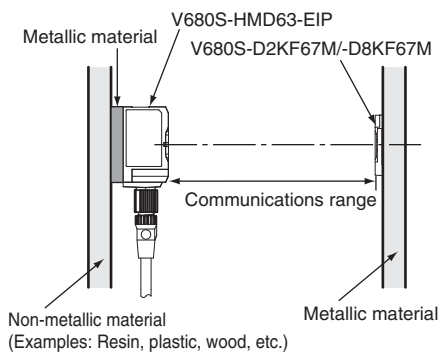

■ V680S-HMD64-EIP

Reader/Writer	RF Tag	Communications Range Specification	
V680S-HMD64-EIP (mounted to metallic material)	V680-D1KP54T (mounted to non-metallic material)	Read	0.0 to 33.0 mm (axis offset: ±10 mm)
		Write	0.0 to 28.0 mm (axis offset: ±10 mm)
	V680-D1KP66T (mounted to non-metallic material)	Read	0.0 to 47.0 mm (axis offset: ±10 mm)
		Write	0.0 to 42.0 mm (axis offset: ±10 mm)
	V680-D1KP66MT (mounted to metallic material)	Read	0.0 to 35.0 mm (axis offset: ±10 mm)
		Write	0.0 to 30.0 mm (axis offset: ±10 mm)
	V680-D1KP66T-SP (mounted to non-metallic material)	Read	0.0 to 42.0 mm (axis offset: ±10 mm)
		Write	0.0 to 37.0 mm (axis offset: ±10 mm)
	V680-D1KP58HTN	Read	7.5 to 75.0 mm (axis offset: ±10 mm)
		Write	7.5 to 75.0 mm (axis offset: ±10 mm)
	V680S-D2KF67 (mounted to non-metallic material)	Read	5.0 to 65.0 mm (axis offset: ±10 mm)
		Write	5.0 to 65.0 mm (axis offset: ±10 mm)
	V680S-D2KF67M (mounted to metallic material)	Read	3.0 to 40.0 mm (axis offset: ±10 mm)
		Write	3.0 to 40.0 mm (axis offset: ±10 mm)
	V680S-D8KF67 (mounted to non-metallic material)	Read	5.0 to 65.0 mm (axis offset: ±10 mm)
		Write	5.0 to 65.0 mm (axis offset: ±10 mm)
	V680S-D8KF67M (mounted to metallic material)	Read	3.0 to 40.0 mm (axis offset: ±10 mm)
		Write	3.0 to 40.0 mm (axis offset: ±10 mm)
	V680S-D2KF68 (mounted to non-metallic material)	Read	7.5 to 75.0 mm (axis offset: ±10 mm)
		Write	7.5 to 75.0 mm (axis offset: ±10 mm)
V680S-D2KF68M (mounted to metallic material)	Read	5.5 to 55.0 mm (axis offset: ±10 mm)	
	Write	5.5 to 55.0 mm (axis offset: ±10 mm)	
V680S-D8KF68 (mounted to non-metallic material)	Read	7.5 to 75.0 mm (axis offset: ±10 mm)	
	Write	7.5 to 75.0 mm (axis offset: ±10 mm)	
V680S-D8KF68M (mounted to metallic material)	Read	5.5 to 55.0 mm (axis offset: ±10 mm)	
	Write	5.5 to 55.0 mm (axis offset: ±10 mm)	

■ Installation Conditions

● V680S-D2KF67/-D8KF67

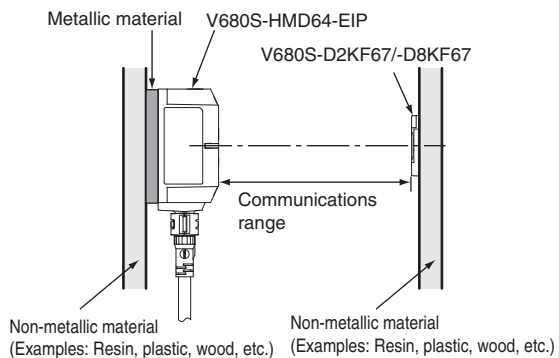

● V680S-D2KF67/-D8KF67M

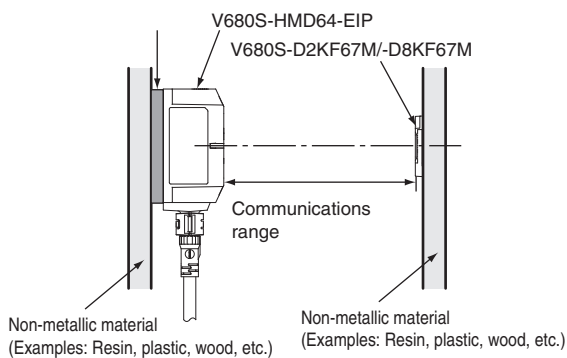

● V680S-D2KF68/-D8KF68

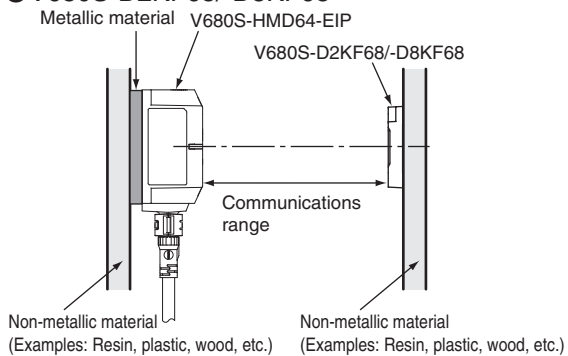

● V680S-D2KF68/-D8KF68M

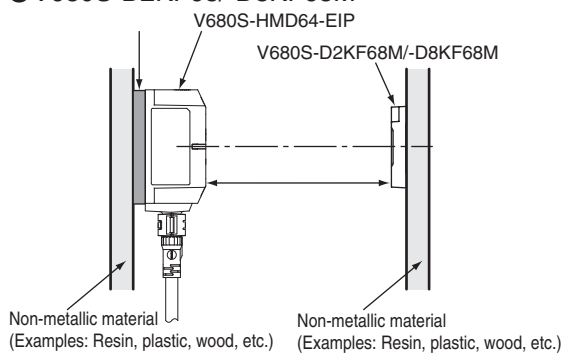

● **V680-D1KP54T**

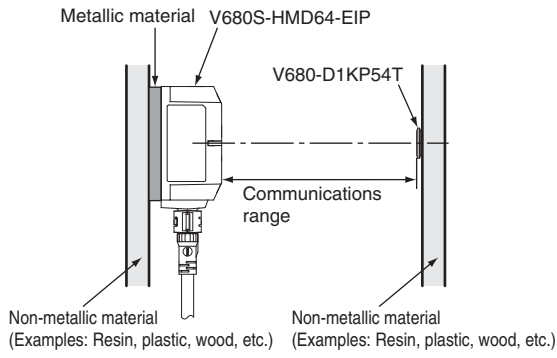

● **V680-D1KP66T**

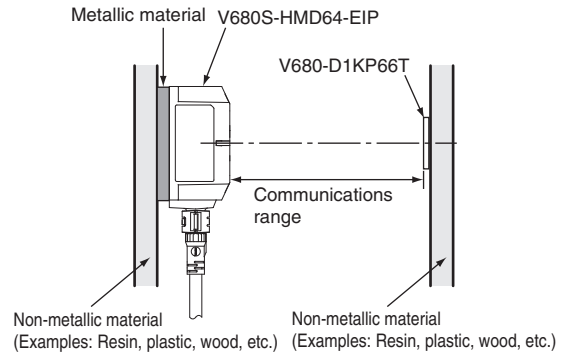

● **V680-D1KP66MT**

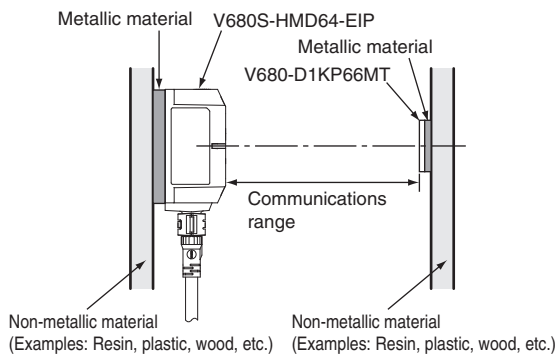

● **V680-D1KP66T-SP**

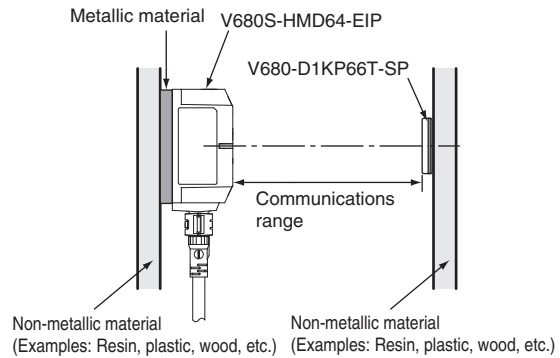

● **V680-D1KP58HTN**

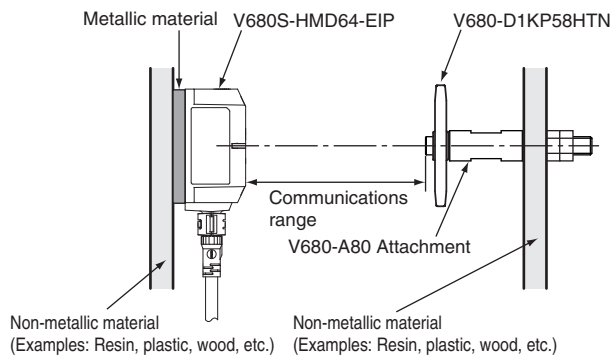

■ V680S-HMD66-EIP

Reader/Writer	RF Tag	Communications Range Specification	
V680S-HMD66-EIP (mounted to metallic material)	V680-D1KP54T (mounted to non-metallic material)	Read	7.5 to 75.0 mm (axis offset: ±10 mm)
		Write	7.5 to 75.0 mm (axis offset: ±10 mm)
	V680-D1KP66T (mounted to non-metallic material)	Read	0.0 to 45.0 mm (axis offset: ±10 mm)
		Write	0.0 to 38.0 mm (axis offset: ±10 mm)
	V680-D1KP66MT (mounted to metallic material)	Read	0.0 to 37.0 mm (axis offset: ±10 mm)
		Write	0.0 to 30.0 mm (axis offset: ±10 mm)
	V680-D1KP66T-SP (mounted to non-metallic material)	Read	0.0 to 59.0 mm (axis offset: ±10 mm)
		Write	0.0 to 52.0 mm (axis offset: ±10 mm)
	V680-D1KP58HTN	Read	10.0 to 90.0 mm (axis offset: ±10 mm)
		Write	10.0 to 800.0 mm (axis offset: ±10 mm)
	V680S-D2KF67 (mounted to non-metallic material)	Read	7.0 to 70.0 mm (axis offset: ±10 mm)
		Write	7.0 to 70.0 mm (axis offset: ±10 mm)
	V680S-D2KF67M (mounted to metallic material)	Read	4.0 to 45.0 mm (axis offset: ±10 mm)
		Write	4.0 to 45.0 mm (axis offset: ±10 mm)
	V680S-D8KF67 (mounted to non-metallic material)	Read	7.0 to 70.0 mm (axis offset: ±10 mm)
		Write	7.0 to 70.0 mm (axis offset: ±10 mm)
	V680S-D8KF67M (mounted to metallic material)	Read	4.0 to 45.0 mm (axis offset: ±10 mm)
		Write	4.0 to 45.0 mm (axis offset: ±10 mm)
	V680S-D2KF68 (mounted to non-metallic material)	Read	10.0 to 100.0 mm (axis offset: ±10 mm)
		Write	10.0 to 100.0 mm (axis offset: ±10 mm)
V680S-D2KF68M (mounted to metallic material)	Read	7.5 to 75.0 mm (axis offset: ±10 mm)	
	Write	7.5 to 75.0 mm (axis offset: ±10 mm)	
V680S-D8KF68 (mounted to non-metallic material)	Read	10.0 to 100.0 mm (axis offset: ±10 mm)	
	Write	10.0 to 100.0 mm (axis offset: ±10 mm)	
V680S-D8KF68M (mounted to metallic material)	Read	7.5 to 75.0 mm (axis offset: ±10 mm)	
	Write	7.5 to 75.0 mm (axis offset: ±10 mm)	



You can use the V680S-D8KF6□ with Reader/Writers with firmware version 2.00 or higher.

CHECK!

■ Installation Conditions

● V680S-D2KF67/-D8KF67

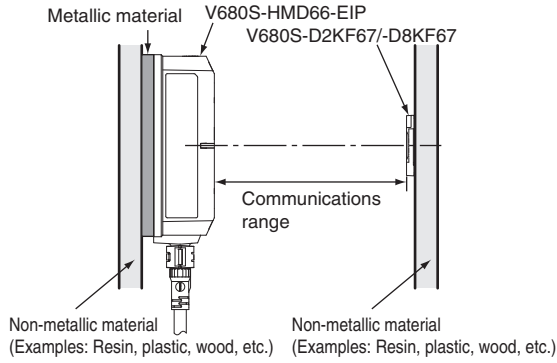

● V680S-D2KF67M/-D8KF67M

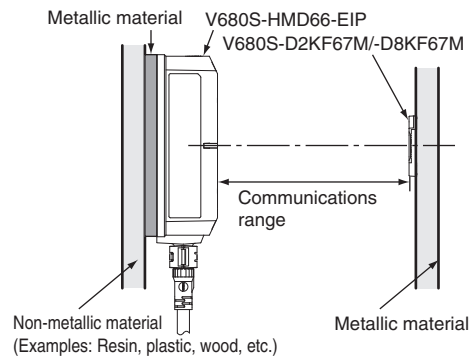

● V680S-D2KF68/-D8KF68

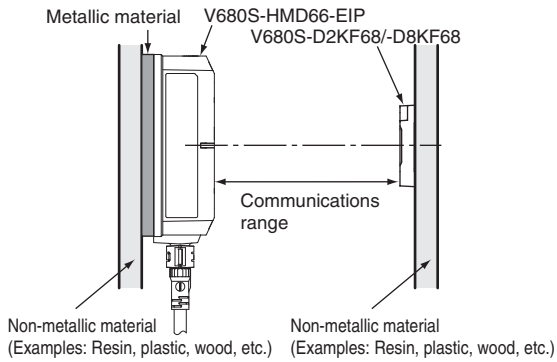

● V680S-D2KF68M/-D8KF68M

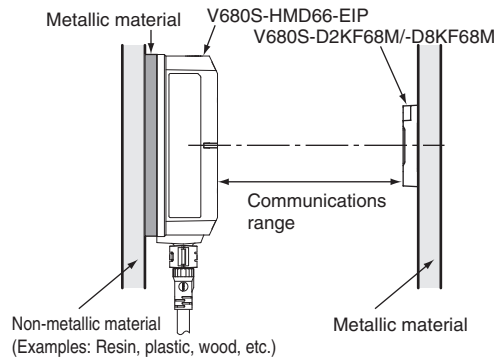

● V680-D1KP54T

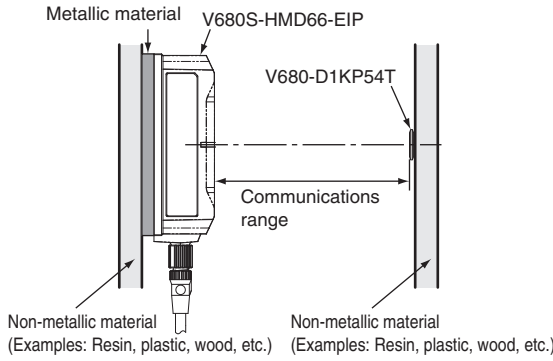

● V680-D1KP66T

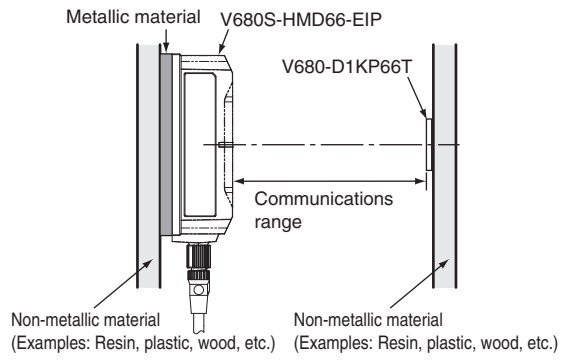

● V680-D1KP66MT

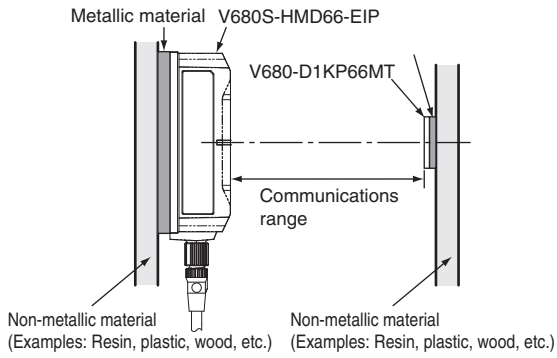

● V680-D1KP66T-SP

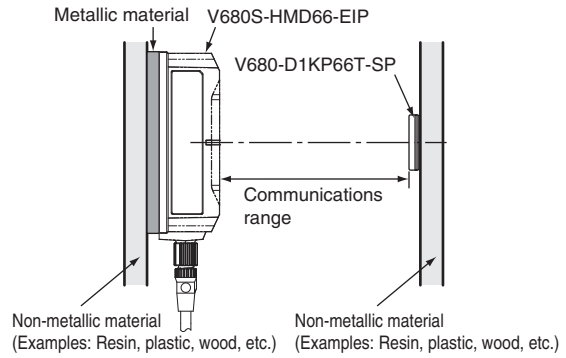

● V680-D1KP58HTN

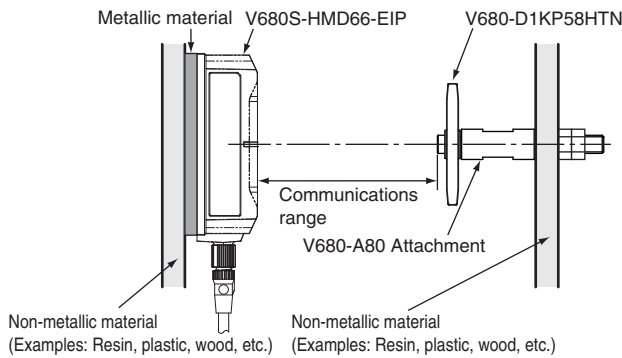

MEMO

Section 2

System Configuration

 System Configuration

52

System Configuration

■ One Reader/Writer is connected to the Host device (e.g., PLC)

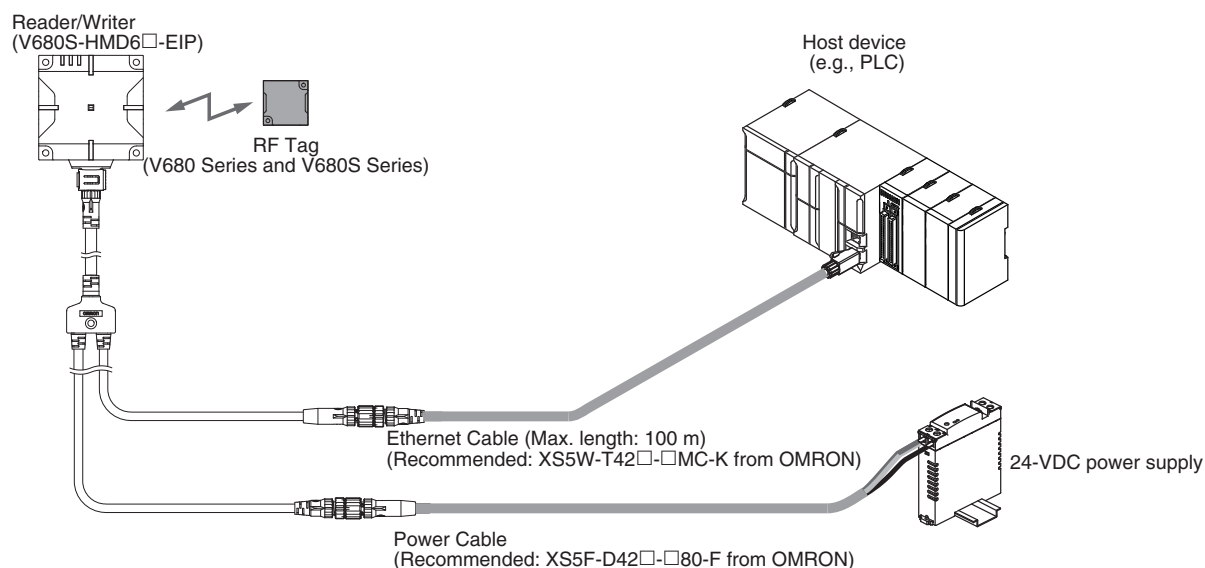

Connect the Ethernet Cable to a host device (e.g., Switching Hub or PLC) that supports STP and ground the host device to 100 Ω or less.

CHECK!



Use a host device (PLC) that can set connections as the originator (i.e., the side that requests opening a communications line for tag data links).

CHECK!

■ The plural Reader/Writer's are connected to the Host device (e.g., PLC)

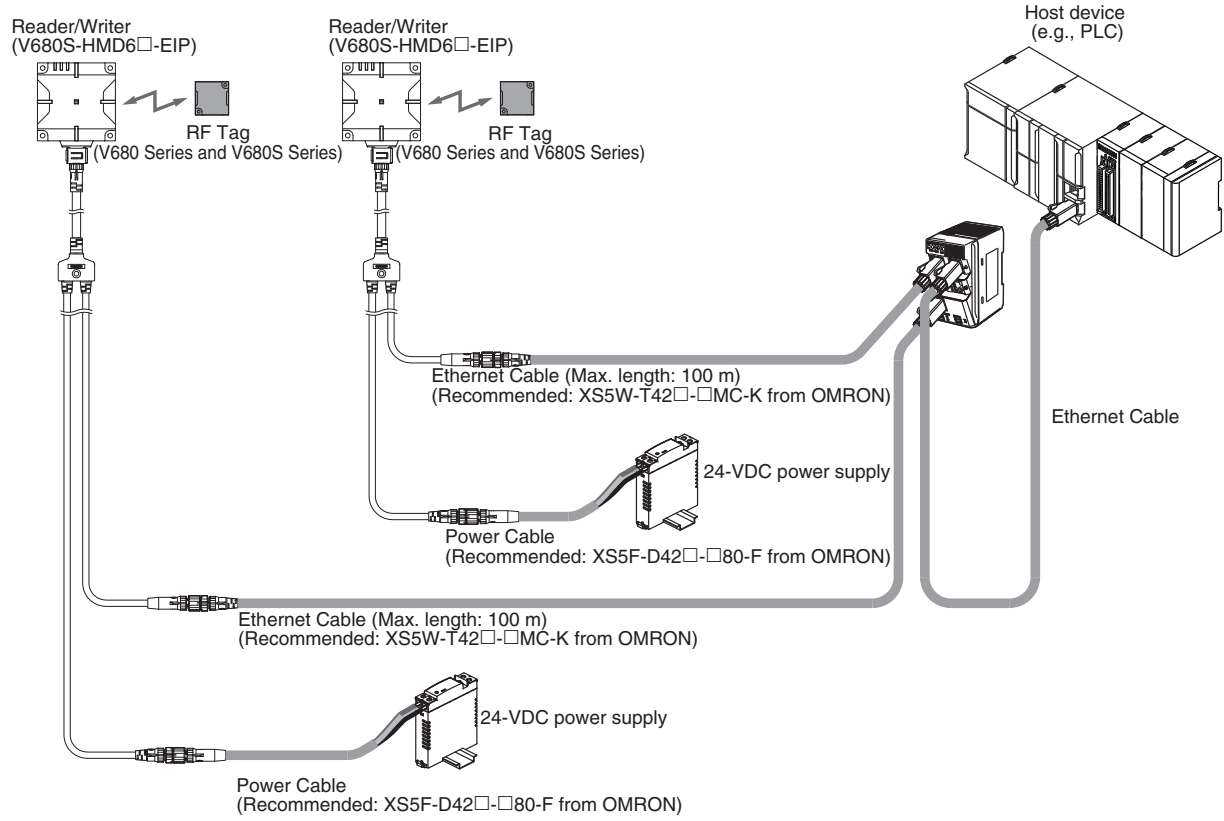

Connect the Ethernet Cable to a host device (e.g., Switching Hub or PLC) that supports STP and ground the host device to 100 Ω or less.

CHECK!



Always use a Switching Hub on any network where tag data links are used.

CHECK!



If you use a repeater hub on a network on which EtherNet/IP tag data links (cyclic communications) are used, the network communications load will increase causing frequent collisions and unstable communications.

CHECK!



Use a host device (PLC) that can set connections as the originator (i.e., the side that requests opening a communications line for tag data links).

CHECK!

■ **The computer is connected to monitor the results of communications diagnostics**

The system requirements to use the Web browser are as follows:
 • Internet Explorer 7 or higher running on Windows XP or Windows 7
 • JRE Version 8.0 or higher
 For details, refer to *Section 8 Browser Interface*.

 p.187

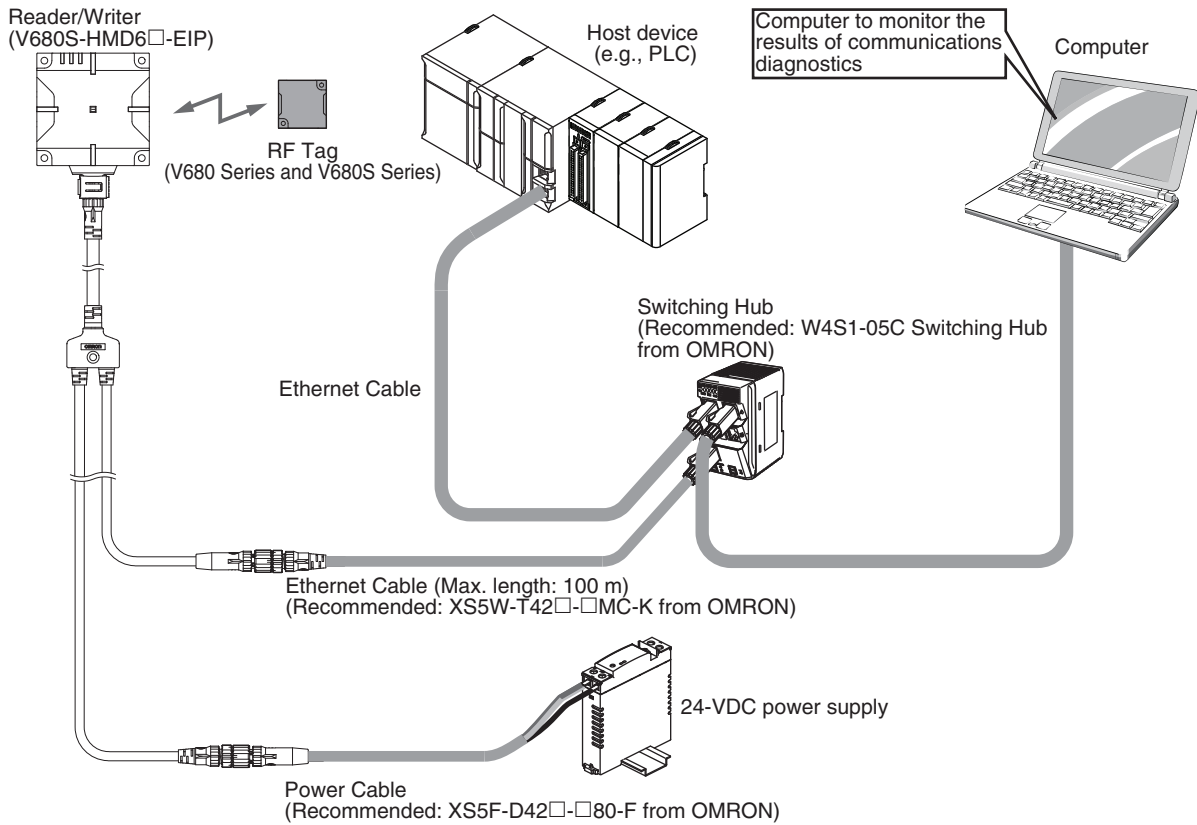

Connect the Ethernet Cable to a host device (e.g., Switching Hub or PLC) that supports STP and ground the host device to 100 Ω or less.

CHECK!



Always use a Switching Hub on any network where tag data links are used.

CHECK!



If you use a repeater hub on a network on which EtherNet/IP tag data links (cyclic communications) are used, the network communications load will increase causing frequent collisions and unstable communications.

CHECK!



Use a host device (PLC) that can set connections as the originator (i.e., the side that requests opening a communications line for tag data links).

CHECK!

■ About the Ethernet communication abnormality



If an Ethernet network is configured into a loop as shown below, broadcast packets are accumulated in the band, and the communication is disabled. Therefore, do not configure the Ethernet network into a loop.

CHECK!

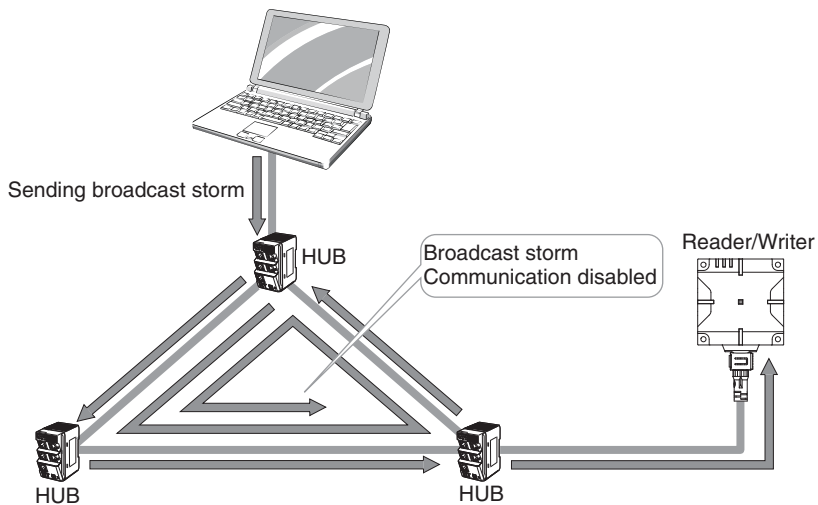

When a large amount of broadcast packets or multicast packets flow into the Ethernet network, Reader/Writers may stop its operation. Please do not send a large amount of packet. Please separate the Reader/Writers from the network segment that broadcast or multicast packets flow.

CHECK!

MEMO

Section 3

Names and Functions of Components

 Component Names	58
Reader/Writer	58
RF Tag	62

Component Names

Reader/Writer

V680S-HMD63-EIP

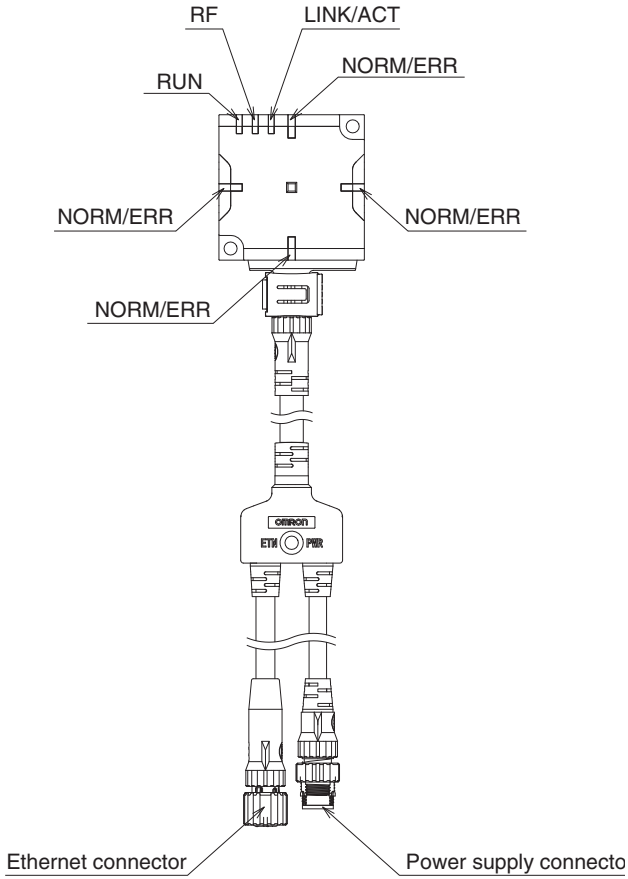

V680S-HMD64-EIP

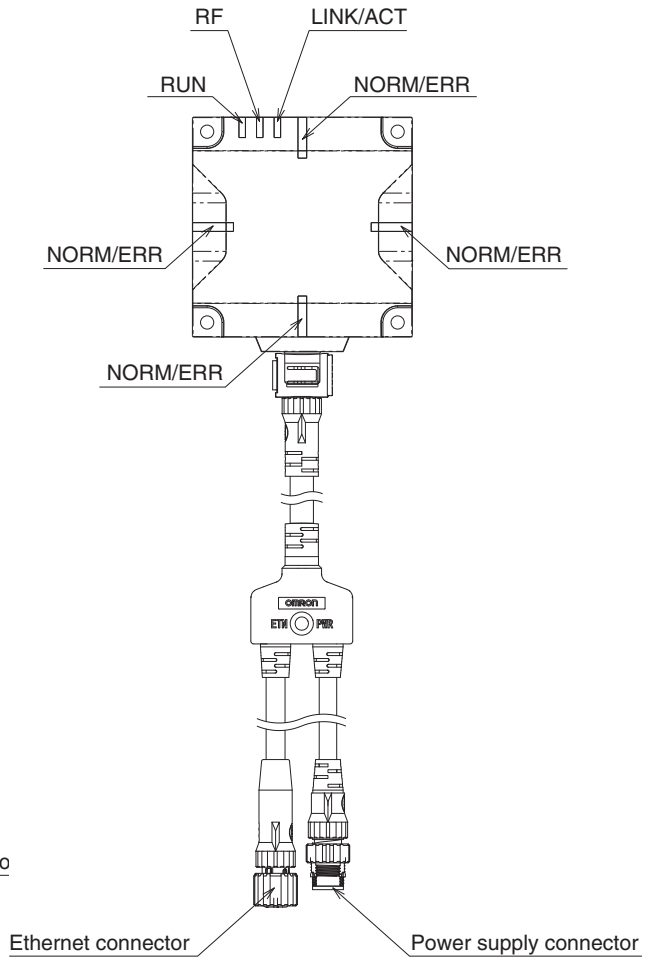

V680S-HMD66-EIP

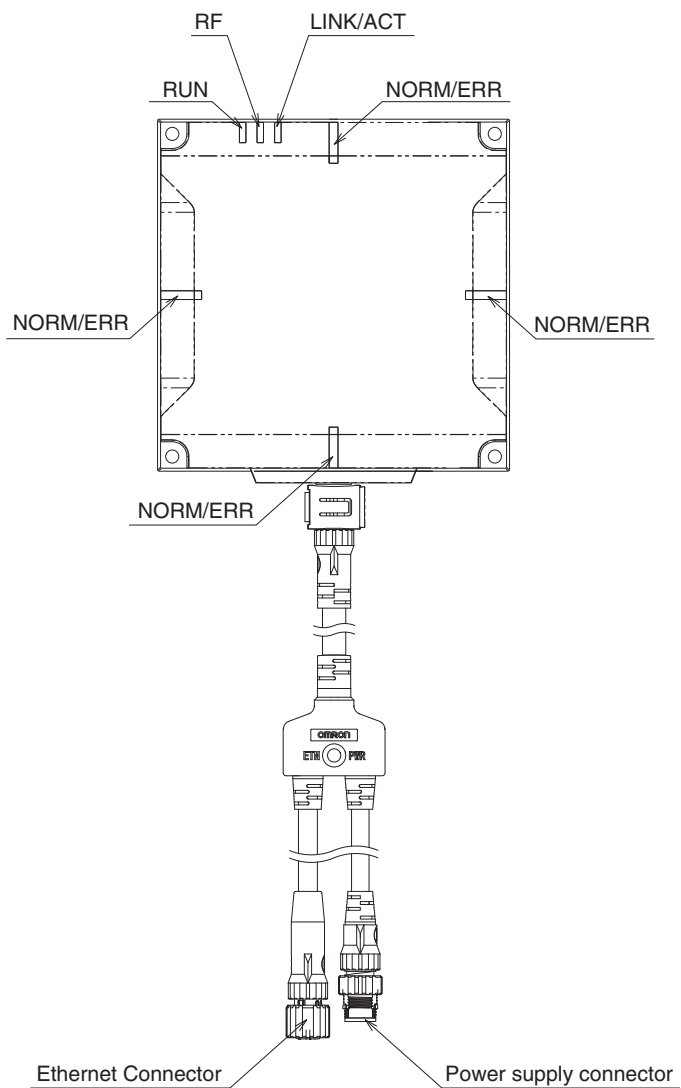

■ Operation Indicators

■ RUN

Status	Meaning
Lit green	Lighting while the Reader/Writer is operating normally.
Flashing green	Flashes during operation in Safe Mode. (Flashes at 1-s intervals.)
Flashing green quickly	The indicator will flash quickly in the following cases. (Flashes at 200-ms intervals.) <ul style="list-style-type: none"> • During Reader/Writer initialization • While the Reader/Writer is in Run Mode and is waiting to establish tag data links as the originator
Lit yellow	Lights yellow while the Reader/Writer is operating in Slave Mode.
Flashing yellow quickly	Flashes quickly while the Reader/Writer is in Slave Mode and is waiting to establish tag data links as the originator.
Not lit	Turn off when power is not supplied.

■ RF

Status	Meaning
Lit yellow	Lighting during communication for RF Tag.
Not lit	Turn off when not in communication with no error.

■ NORM/ERR

The NORM/ERR indicator shows the result of communications with an RF Tag.

Status	Meaning
Lit green	Lights once when processing a communications command or another command from the host device is completed normally. When communication diagnostic is enabled, this indicator will flash once each time a stable communication is detected.
Lit yellow	When communication diagnostic is enabled, this indicator will flash once each time an unstable communication is detected.
Flashing yellow quickly	Flashes quickly when a timeout is detected during tag data links. (A timeout occurs when tag data from the originator is not received within the time specified for the timeout value.)
Lit red	Lights once when processing a communications command or another command from the host device ends in an error. It continues to light if a system error occurred.
Flashing red	Flash when recoverable error occurs. (Configuration memory error, or Control signal wiring mistake, etc.)
Flashing red irregularly	The indicator will flash irregularly in the following cases. (It will repeatedly flash twice for 100 ms at 1-s intervals.) <ul style="list-style-type: none"> • When the same IP address is detected for two different devices on the network at startup • When an error occurs when getting an IP address from the BOOTP server at startup (The BOOTP server does not respond. The IP address from the BOOTP server to set in the Reader/Writer is illegal.)
Not lit	Turn off when the standby state.

■ LINK/ACT

Status	Meaning
Lit green	Lighting during linking normally.
Flashing green	Flash during detects a carrier.
Not lit	Turn off when the ethernet cable is not connected.

Refer to *Errors and Indicator Status* in *Section 9 Troubleshooting* for information of Error content of the operation indicator



■ Connector

■ Power Supply Connector (M12 A-Coding)

Power Supply Connector (M12 A-Coding, male)

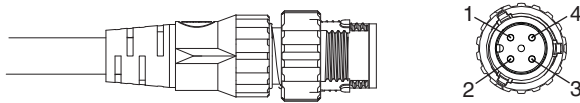

Pin No.	Name	Description	I/O
1	24P	+24 V	---
2	CONT	Control signal (operating mode signal) * Run Mode: Connect to +24 V and then start the Reader/Writer. Safe Mode: Connect to 0 V and then start the Reader/Writer.	IN
3	24N	0 V	---
4	-	-	---

■ Ethernet Connector (M12 D-Coding)

Ethernet Connector (M12 D-Coding, female)

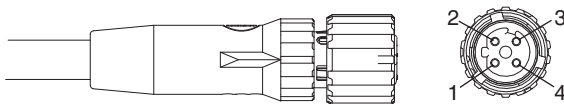

Pin No.	Name	Description	I/O
1	TD+	Ethernet send signal +	OUT
2	RD+	Ethernet receive signal +	IN
3	TD-	Ethernet send signal -	OUT
4	RD-	Ethernet receive signal -	IN
Housing	FG	Frame ground	---



If an Ethernet network is configured into a loop as shown below, broadcast packets are accumulated in the band, and the communication is disabled. Therefore, do not configure the Ethernet network into a loop.

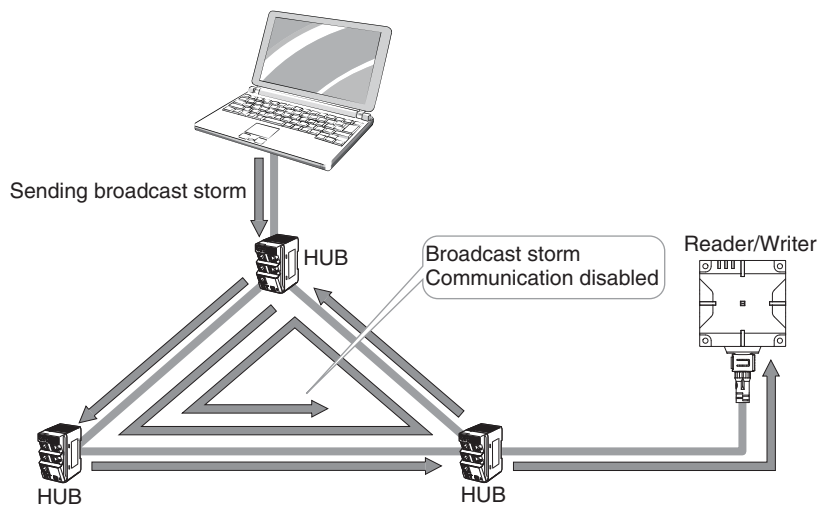

When a large amount of broadcast packets or multicast packets flow into the Ethernet network, Reader/Writers may stop its operation. Please do not send a large amount of packet. Please separate the Reader/Writers from the network segment that broadcast or multicast packets flow.

RF Tag

The model numbers of the RF Tags that can communicate with the Reader/Writer are given in this section. For the communications range specifications, refer to *Communications Range Specifications* in *Section 1 Product Overview*.

 p.42

(Unit: mm)

■ V680-D1KP54T



Shape: 20 dia. × 2.7

■ V680-D1KP66T/-D1KP66MT

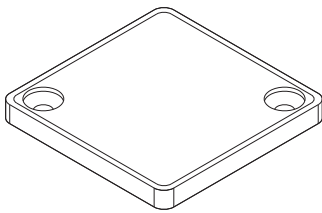

Shape: 34 × 34 × 3.5 (W × H × D)

■ V680-D1KP66T-SP

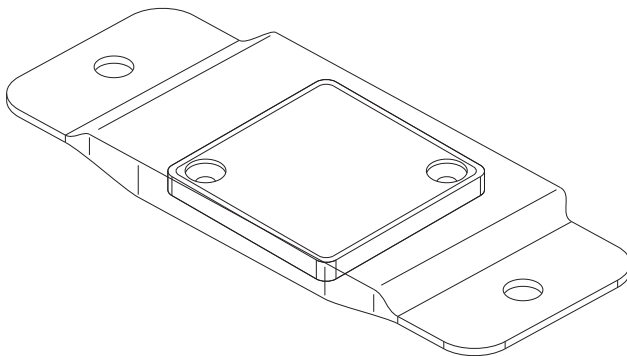

Shape: 95 × 36.5 × 6.5 (W × H × D)
(excluding protruding parts)

■ V680-D1KP58HTN

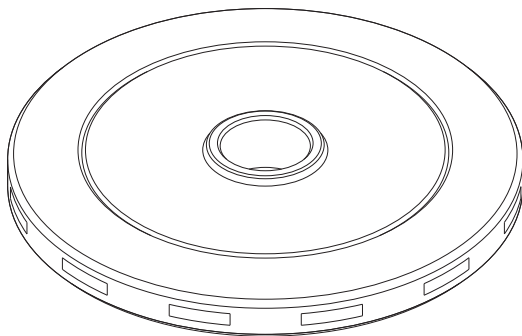

Shape: 80 dia. × 10

(Unit: mm)

■ V680S-D2KF67/-D2KF67M/-D8KF67/-D8KF67M

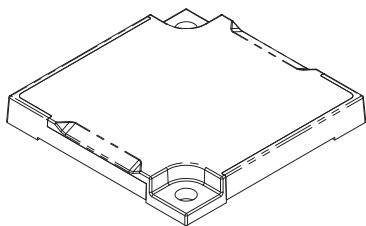

Shape: 40 × 40 × 5 (W × H × D)

■ V680S-D2KF68/-D2KF68M/-D8KF68/-D8KF68M

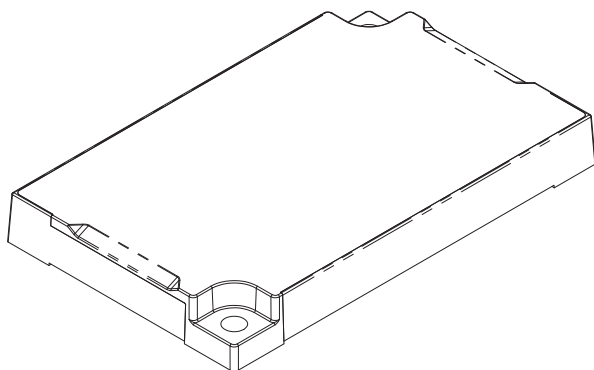

Shape: 86 × 54 × 10 (W × H × D)



CHECK!

You can use the V680S-D8KF6□ with Reader/Writers with firmware version 2.00 or higher.

MEMO

Section 4

Installation and Connections

☒ Installation	66
Reader/Writer	66
Connector Cover	69
RF Tag	71
☒ Connections and Wiring	78
Connecting and Removing the Reader/Writer Power Cable and Ethernet Cable	78

Installation

Reader/Writer

■ V680S-HMD63-EIP

Install the Reader/Writer with two M4 screws. Use both spring washers and flat washer.

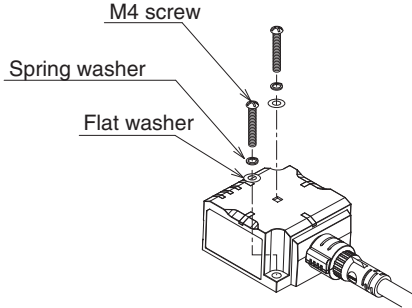

Mounting Hole Dimensions

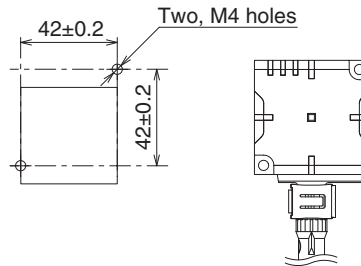

(Unit: mm)

When you install the Reader/Writer, prepare the metal plate shown in the following figure. When the metal plates size is larger than the below illustration, communication range will change.

Material: Steel

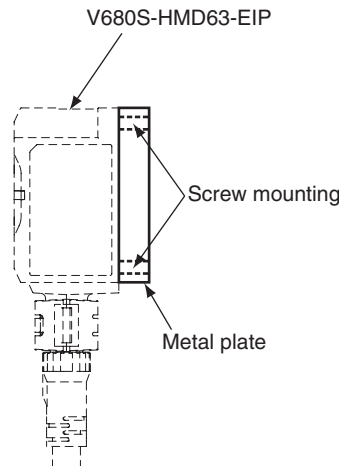
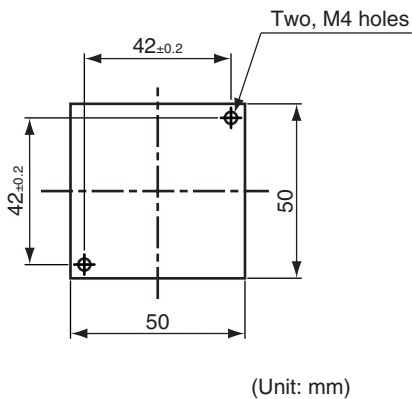

Although it is possible to use SUS, aluminum or brass in addition to steel as the metal plate, communications range is influenced by the material. Do not use resin as the metal plate.



The recommended tightening torque for M4 screws is 1.2 N·m.

Refer to *Reader/Writer Installation Precautions* in *Section 11 Appendices* for information of surrounding metal and Mutual Interference of Reader/Writers.

 p.254

■ V680S-HMD64-EIP

Install the Reader/Writer with four M4 screws. Use both spring washers and flat washers.

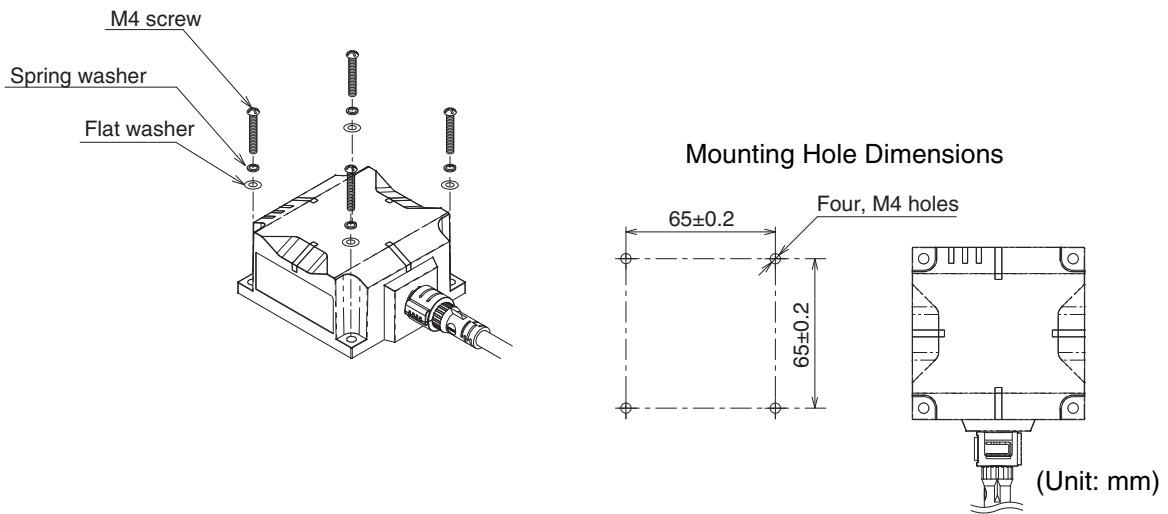

When you install the Reader/Writer, prepare the metal plate shown in the following figure. When the metal plates size is larger than the below illustration, communication range will change.

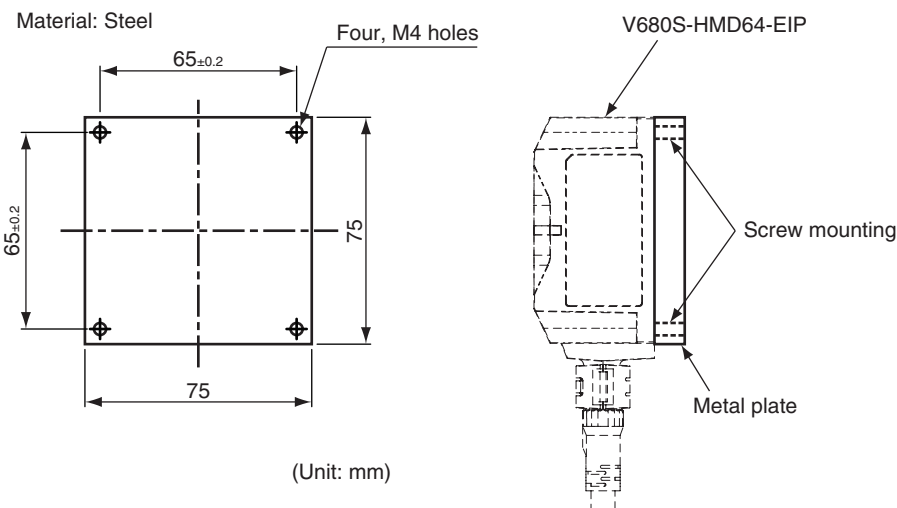

 Although it is possible to use SUS, aluminum or brass in addition to steel as the metal plate, communications range is influenced by the material. Do not use resin as the metal plate.

CHECK!

 The recommended tightening torque for M4 screws is 1.2 N·m.

CHECK!

Refer to *Reader/Writer Installation Precautions* in *Section 11 Appendices* for information of surrounding metal and Mutual Interference of Reader/Writers.

 p.254

■ V680S-HMD66-EIP

Install the Reader/Writer with four M4 screws. Use both spring washers and flat washers.

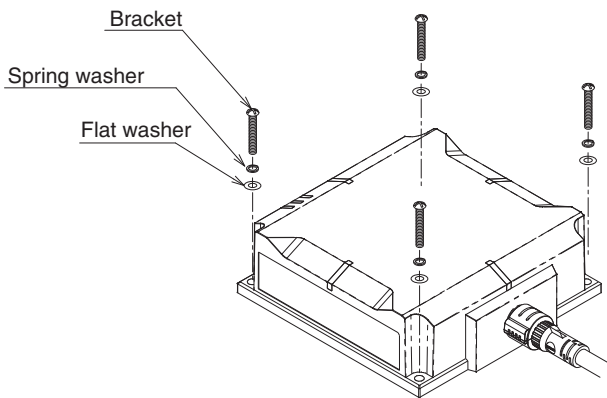

Mounting Hole Dimensions

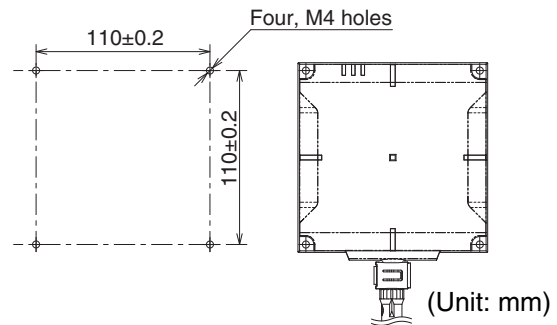

When you install the Reader/Writer, prepare the metal plate shown in the following figure. When the metal plates size is larger than the below illustration, communication range will change.

Material: Steel

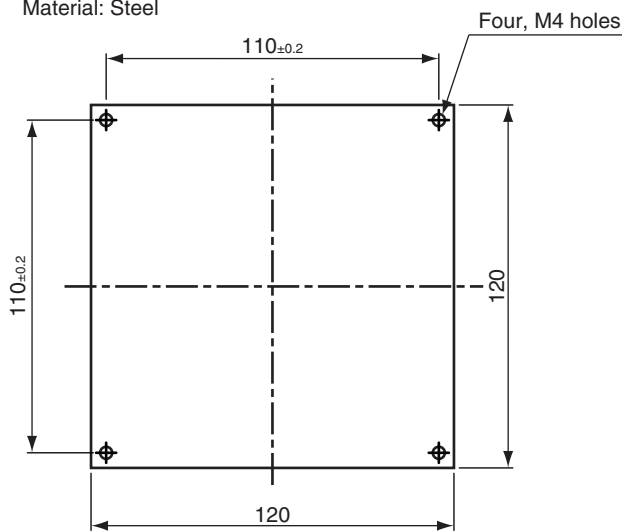

V680S-HMD66-EIP

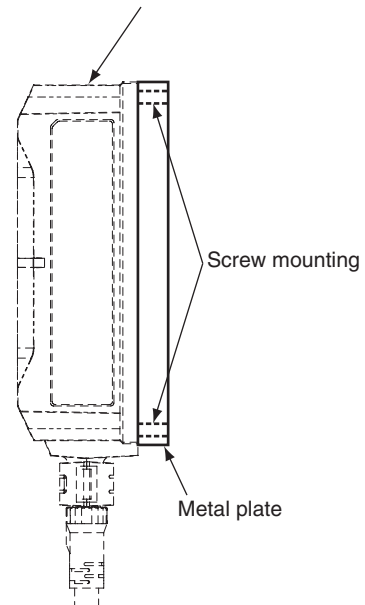

Although it is possible to use SUS, aluminum or brass in addition to steel as the metal plate, communications range is influenced by the material. Do not use resin as the metal plate.

CHECK!



The recommended tightening torque for M4 screws is 1.2 N-m.

CHECK!

Refer to *Reader/Writer Installation Precautions* in *Section 11 Appendices* for information of surrounding metal and Mutual Interference of Reader/Writers.

p.254

Connector Cover

■ V680S-A63-S

Either use the V680S-A63-S Attachment to mount the Connector Cover with screws or permanently attach the RF Tags with adhesive.

1. Through a cord into a connector cover.

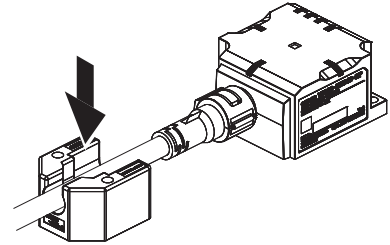

2. Press a connector cover up until it clicks.

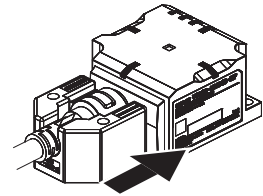

3. Install the connector cover with two M4 screws.
Tightening torque: 1.2 N·m

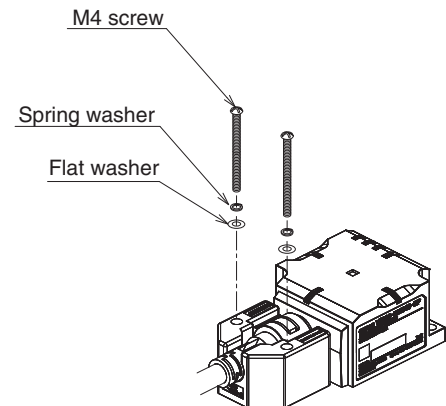

When removing a connector, please remove the screw on which a connector cover is being fixed and shift a connector cover.

(1),(2),(3) above-mentioned is reverse.

■ V680S-A64-S

Either use the V680S-A64-S Attachment to mount the Connector Cover with screws or permanently attach the RF Tags with adhesive.

1. Through a cord into a connector cover.

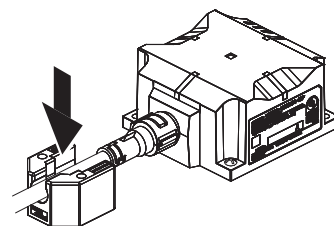

2. Press a connector cover up until it clicks.

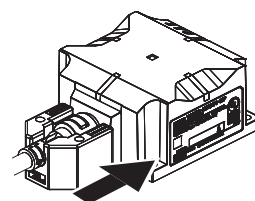

3. Install the connector cover with two M4 screws.
Tightening torque: 1.2 N·m

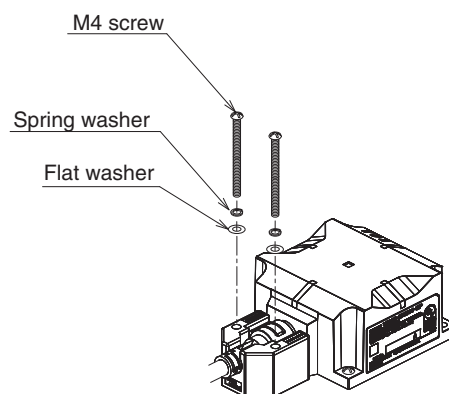

When removing a connector, please remove the screw on which a connector cover is being fixed and shift a connector cover.
CHECK! (1),(2),(3) above-mentioned is reverse.

RF Tag

■ V680-D1KP54T

Either use the V700-A80 Attachment to mount the RF Tags with screws or permanently attach the RF Tags with adhesive.

Installation with the V700-A80 Attachment

1. Place the V680-D1KP54T RF Tag in the Attachment.

The V680-D1KP54T RF Tag can be placed in the Attachment in either direction.
The direction does not affect operation.

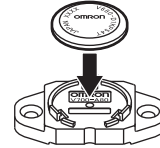

CHECK!

Do not repeatedly place the RF Tag in the Attachment and remove it from the Attachment. If you do so, the RF Tag will become loose or the Attachment will be damaged.

If you must remove an RF Tag from the Attachment, insert a flat-blade screwdriver in the gap under the RF Tag. Do not try to remove it with your bare hands. Doing so may result in injury.

2. Mount the Attachment with M3 screws.

Tighten the screws to a suitable torque.
Tightening torque: 0.3 to 0.5 N·m

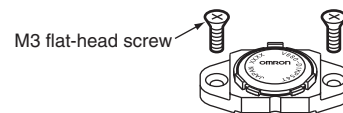

Mounting Hole Dimensions

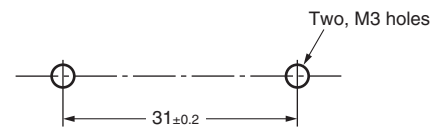

■ Installation with Adhesive

Select an adhesive that is suitable for the materials. Use the correct application method and amount.
Always confirm that the RF Tag is securely attached before you use it.

The RF Tags are made from PPS resin. We recommend epoxy adhesives to mount them on metal or hard plastic.

The epoxy adhesives that are listed in the following table are recommended for the given temperature ranges.

Ambient operating temperature	Product name	Manufacturer
-40 to 70°C	Two-part Epoxy Adhesive: TB2001 (main agent)/TB2105C (curing agent)	ThreeBond Co., Ltd.
	One-part Moisture-curing Elastic Adhesive: TB1530	ThreeBond Co., Ltd.
-40 to 110°C	Two-part Epoxy Adhesive: EP001	Cemedine Co. Ltd.
-40 to 150°C	One-part Epoxy Adhesive: TB2285	ThreeBond Co., Ltd.
	Two-part Epoxy Adhesive: TB2087	ThreeBond Co., Ltd.



CHECK!

The above adhesives may not provide sufficient strength when attaching RF Tags to polyethylene, polypropylene, fluororesins, or silicon-based resins. Check applicability carefully in advance. Consult with the manufacturer for detailed information on adhesives.

■ V680-D1KP66T

■ Mounting on Non-metallic Material

Mount the RF Tag using M3 flat-head screws from the marked side.

Tighten the screws to a torque of 0.3 to 0.5 N·m.

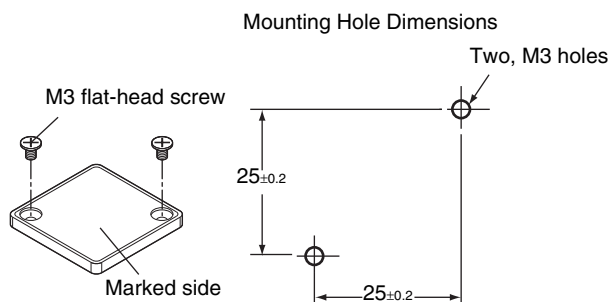

■ Mounting on Metallic Material

The communications range will decrease if there is metal at the back of the V680-D1KP66T RF Tag.

If the RF Tag is mounted on metallic material, use the V600-A86 Attachment (sold separately) or a non-metallic spacer (e.g., plastic or resin).

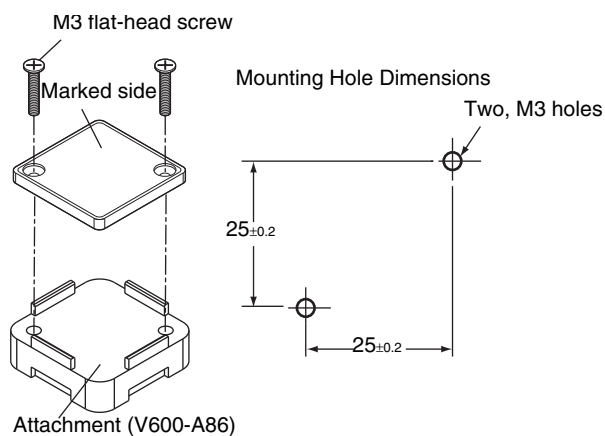

Refer to *RF Tag Installation Precautions* in *Section 11 Appendices* for information on the effect of metal at the back surface, Mutual Interference of RF Tags and Influence of Inclination of the V680-D1KP66T.

 p.259

■ V680-D1KP66MT

Mount the RF Tag using M3 flat-head screws from the marked side.

Tighten the screws to a torque of 0.3 to 0.5 N·m.

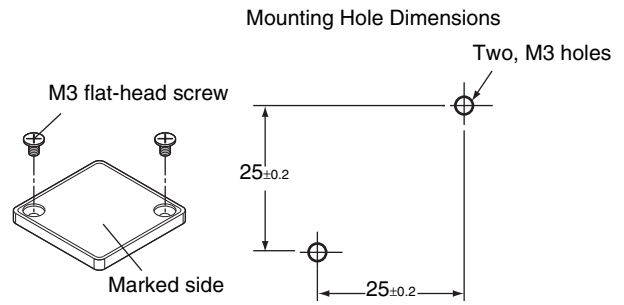

When you install the RF tag, prepare the metal plate as shown in the figure below.

When the metal plates size is larger than the below illustration, communication range will change. Please confirm the influence well.

Material: Steel

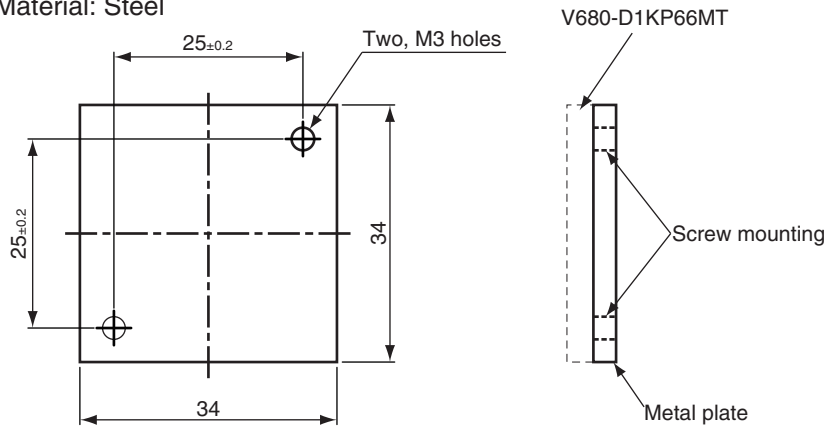

(Unit: mm)



CHECK!

Although it is possible to use SUS, aluminum or brass in addition to steel as the metal plate, communications range is influenced by the material. Do not use resin as the metal plate.

Refer to *RF Tag Installation Precautions* in *Section 11 Appendices* for information on the effect of surrounding metal, Mutual Interference of RF Tags and Influence of Inclination on the V680-D1KP66MT.



p.259

■ V680-D1KP66T-SP

Mount the RF Tag using M5 screws and washers. The tightening torque is 1.2 N·m.

There are no restrictions on the mounting direction for the RF Tag or the direction of RF Tag travel in respect to the Reader/Writer.

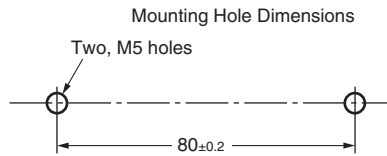
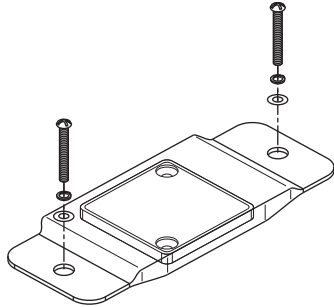

Refer to *RF Tag Installation Precautions* in *Section 11 Appendices* for information on the effect of metal at the back surface, Mutual Interference of RF Tags and Influence of Inclination of the V680-D1KP66T-SP.

 p.259

■ **V680-D1KP58HTN**

Use the following procedure to install an RF Tag with the V680-A80 Attachment.

- 1.** Attach the Attachment to the workpiece.

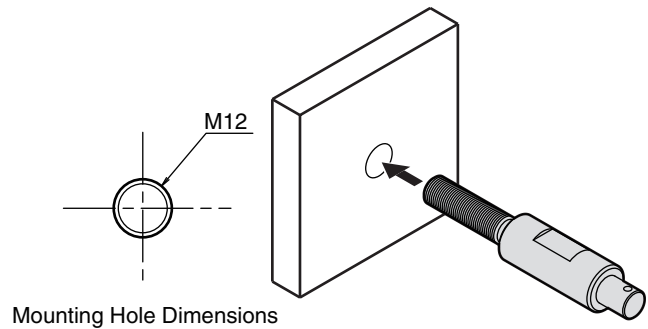

- 2.** Tighten the lock nut.



Use a tightening torque of 21 to 42 N·m.

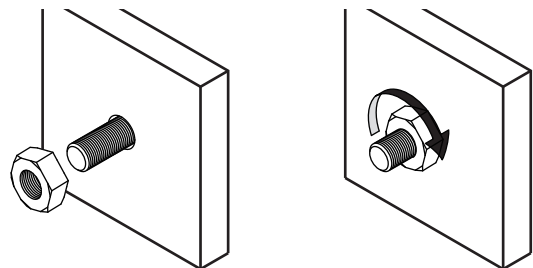

- 3.** Place the RF Tag in the Attachment.



The RF Tag can be attached in either direction. The direction does not affect operation.

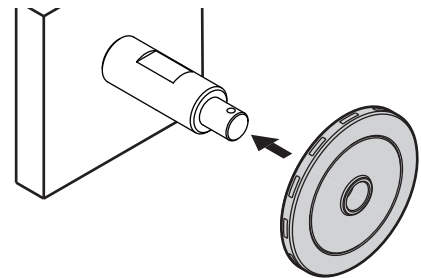

- 4.** Insert the split pin into the 3.2-diameter hole and spread open the end of the pin to prevent it from coming out.

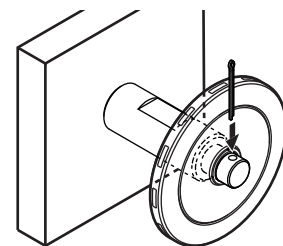

Two nuts and one split pin are provided with the V680-A80 Attachment. You must provide any replacement split pins.

Split pin	Nominal dimensions: 3.2-mm dia. × 20-mm length
-----------	--

Refer to *RF Tag Installation Precautions* in *Section 11 Appendices* for information on the effect of metal at the back surface, Mutual Interference of RF Tags and Influence of Inclination of the V680-D1KP58HTN.



■ V680S-D2KF67/-D8KF67

Mount the RF Tag with M3 screws.
Tighten the screws to a torque of 0.6 N·m.

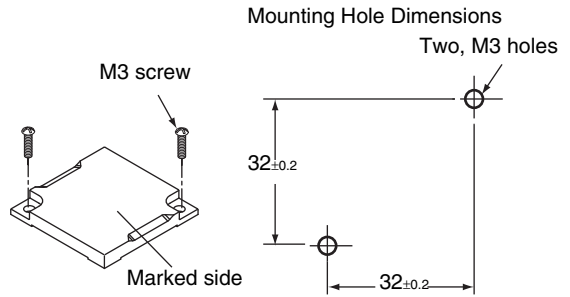

Refer to *RF Tag Installation Precautions* in *Section 11 Appendices* for information on the effect of metal at the back surface, Mutual Interference of RF Tags and Influence of Inclination of the V680S-D2KF67.



Refer to *RF Tag Installation Precautions* in *Section 11 Appendices* for information on the effect of metal at the back surface, Mutual Interference of RF Tags and Influence of Inclination of the V680S-D8KF67.



CHECK!

You can use the V680S-D8KF67 with Reader/Writers with firmware version 2.00 or higher.

■ V680S-D2KF67M/-D8KF67M

Mount the V680-D8KF67M to a metal surface.
Mount the RF Tag with M3 screws.
Tighten the screws to a torque of 0.6 N·m.

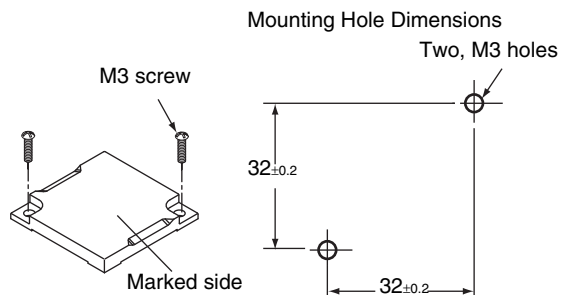

Refer to *RF Tag Installation Precautions* in *Section 11 Appendices* for information on the effect of surrounding metal, Mutual Interference of RF Tags and Influence of Inclination on the V680S-D2KF67M.



Refer to *RF Tag Installation Precautions* in *Section 11 Appendices* for information on the effect of surrounding metal, Mutual Interference of RF Tags and Influence of Inclination on the V680S-D8KF67M.



CHECK!

You can use the V680S-D8KF67M with Reader/Writers with firmware version 2.00 or higher.

■ V680S-D2KF68/-D8KF68

Mount the RF Tag with M4 screws. Tighten the screws to a torque of 0.7 to 1.2 N·m.

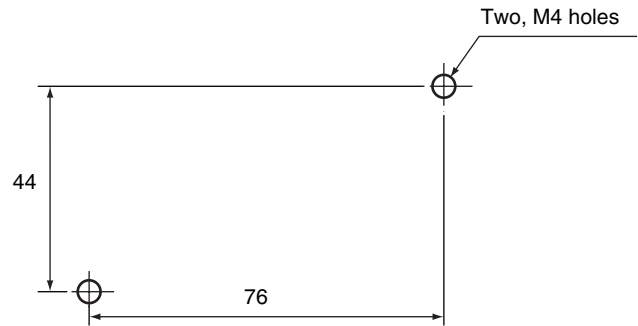
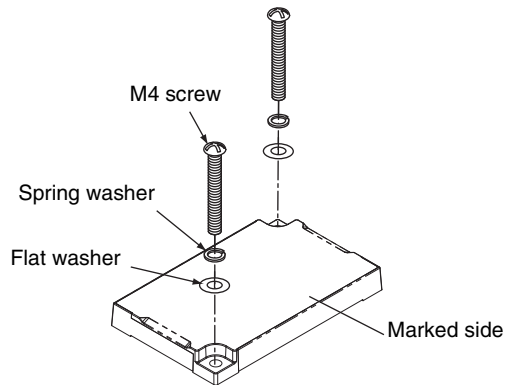

(Unit: mm)

Refer to *RF Tag Installation Precautions* in *Section 11 Appendices* for information on the effect of metal at the back surface, Mutual Interference of RF Tags and Influence of Inclination of the V680S-D2KF68.



Refer to *RF Tag Installation Precautions* in *Section 11 Appendices* for information on the effect of metal at the back surface, Mutual Interference of RF Tags and Influence of Inclination of the V680S-D8KF68.



You can use the V680S-D8KF68 with Reader/Writers with firmware version 2.00 or higher.

CHECK!

■ V680S-D2KF68M/-D8KF68M

Mount the RF Tag with M4 screws. Tighten the screws to a torque of 0.7 to 1.2 N·m.

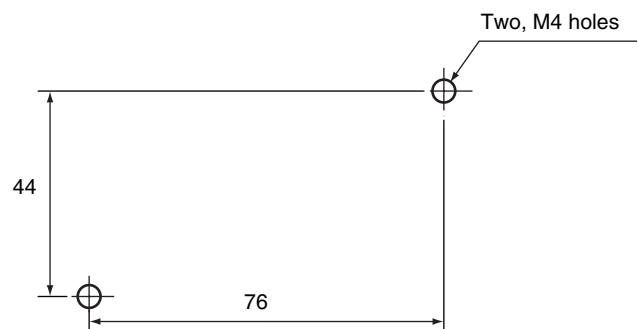
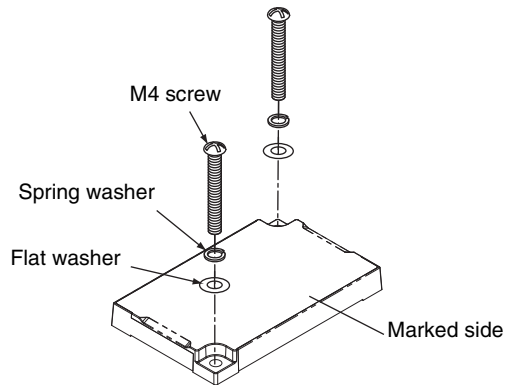

(Unit: mm)

Refer to *RF Tag Installation Precautions* in *Section 11 Appendices* for information on the effect of surrounding metal, Mutual Interference of RF Tags and Influence of Inclination on the V680S-D2KF68M.



Refer to *RF Tag Installation Precautions* in *Section 11 Appendices* for information on the effect of surrounding metal, Mutual Interference of RF Tags and Influence of Inclination on the V680S-D8KF68M.



You can use the V680S-D8KF68M with Reader/Writers with firmware version 2.00 or higher.

CHECK!

Connections and Wiring

Connecting and Removing the Reader/Writer Power Cable and Ethernet Cable

■ Connecting Method

1. Hold onto the connector on the Power Cable and insert it into the power connector on the Reader/Writer.



Do not apply more than 30 N·m of force to the connector on the Reader/Writer.

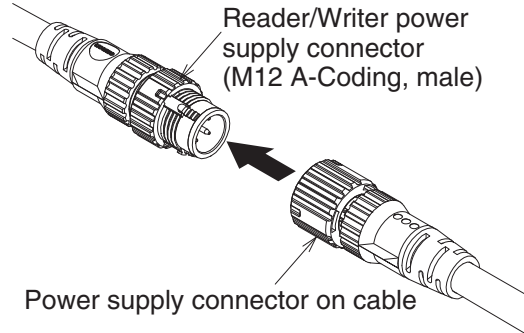

2. Turn the connector on the Power Cable clockwise to lock it in place.

Recommended tightening torque: 0.39 to 0.49 N·m

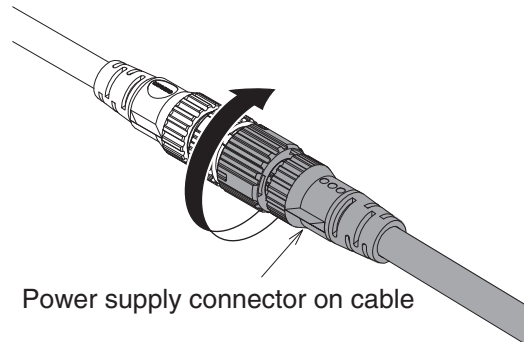

■ Contact arrangement of the Reader/Writer's power connector

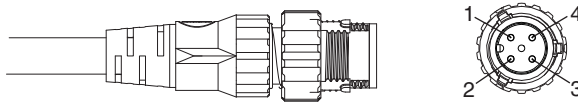

Pin No.	Name	Description	I/O
1	24P	+24 V	---
2	CONT	Control signal (operating mode signal) * Run Mode: Connect to +24 V and then start the Reader/Writer. Safe Mode: Connect to 0 V and then start the Reader/Writer.	IN
3	24N	0 V	---
4	-	-	---
Pin No.	Name	Description	I/O

Refer to *Operation Mode* in *Section 6 Functions* for information on the RUN mode, and Safe mode.



■ Contact arrangement and wiring diagram of the recommended cable (Model XS5F-D42□-□80-F)

Contact arrangement



Wiring cable (Four-core type)

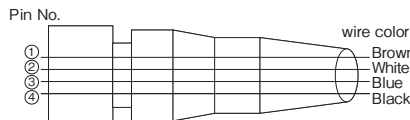

Read and understand the power cable manual before attempting to connect the power cable.

- Hold onto the connector on the Ethernet Cable and insert it into the Ethernet connector on the Reader/Writer.



Do not apply more than 30 N·m of force to the connector on the Reader/Writer.

CHECK!

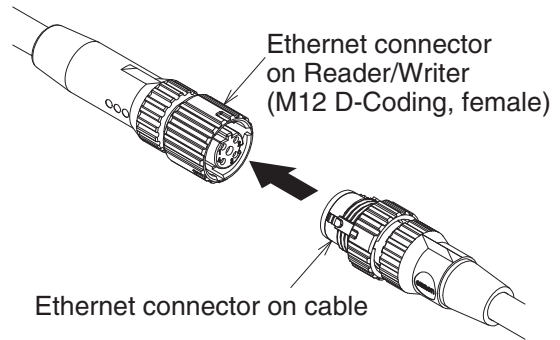

- Turn the connector on the Ethernet Cable clockwise to lock it in place.

Recommended tightening torque: 0.39 to 0.49 N·m

▪ **Contact arrangement of the Reader/Writer's Ethernet connector**

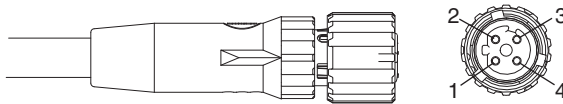

Pin No.	Name	Description	I/O
1	TD+	Ethernet send signal +	OUT
2	RD+	Ethernet receive signal +	IN
3	TD-	Ethernet send signal -	OUT
4	RD-	Ethernet receive signal -	IN
Housing	FG	Frame ground	---

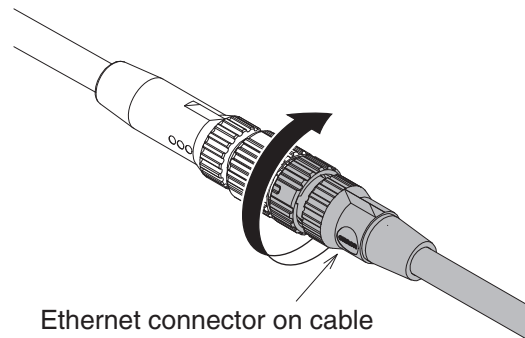

- Mount the Branch Cable with one M4 screw.



Recommended tightening torque: 0.39 to 0.49 N·m

CHECK!

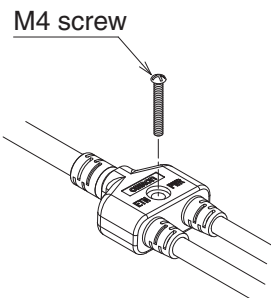

■ Removal Method

1. Turn the connector on the Power Cable counterclockwise to unlock it.

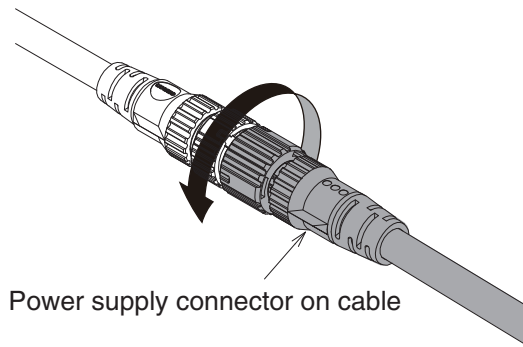

2. Hold onto the connector on the Power Cable and pull it straight out to remove it.



CHECK!

If the connector is difficult to remove, press on the Reader/Writer and pull on the connector. Never pull on the Cable with excessive force. Doing so may break the wires and cause malfunction.

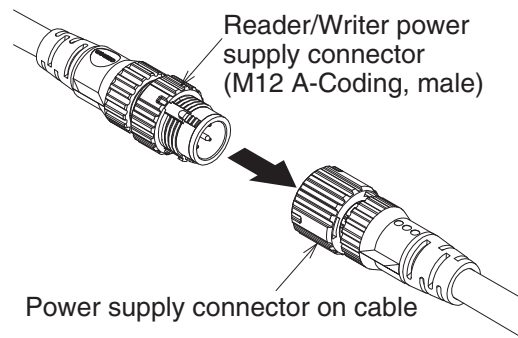

3. Turn the connector on the Ethernet Cable counterclockwise to unlock it.

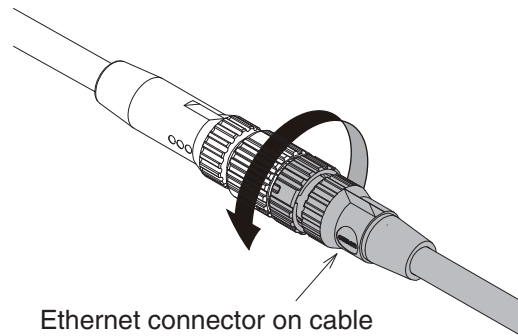

4. Hold onto the connector on the Ethernet Cable and pull it straight out to remove it.



CHECK!

If the connector is difficult to remove, press on the Reader/Writer and pull on the connector. Never pull on the Cable with excessive force. Doing so may break the wires and cause malfunction.

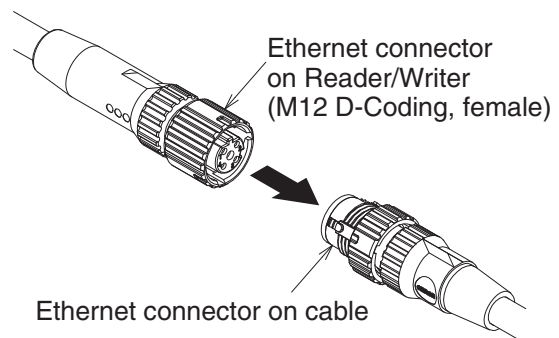

CHECK!

Do not remove the cable bracket from the Reader/Writer.

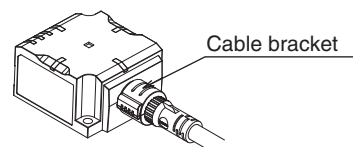

Section 5

Preparations for Communications

▣ Starting the Reader/Writer	82
Reader/Writer Starting Procedure	82
▣ Setting Communications Conditions	83
Preparations for Work	83
Setting the IP Address of the Reader/Writer from a Web Browser	85
Setting the IP Address of the Reader/Writer on the Network Configurator	87
▣ Setting Tag Data Links	90

Starting the Reader/Writer

Reader/Writer Starting Procedure

1. Connect the Cable to the Reader/Writer.

Refer to *Connecting and Removing the Reader/Writer Power Cable and Ethernet Cable* in *Section 4 Installation and Connections* for the connector method.



2. Connect the power supply lines and the operation mode signal line in the Cable to the power source and connect the RJ45 connector to an Ethernet port on the host device.

3. Turn ON the power supply to start the Reader/Writer.

If the Reader/Writer starts normally, the RUN indicator will light green.

Setting Communications Conditions

Preparations for Work

1. Network Configuration

The network configuration that is described in this manual is shown in the following figure. Connect the Reader/Writer and the computer with an Ethernet Cable.

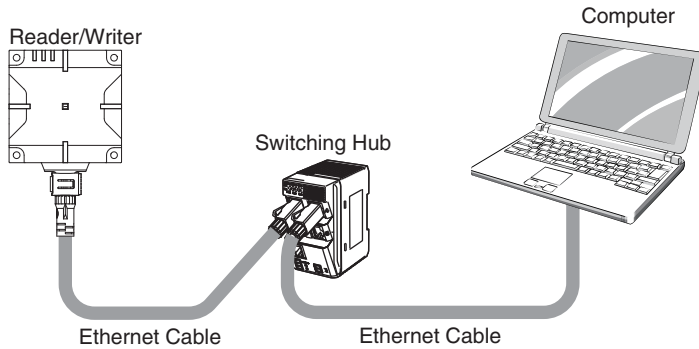

2. Set the IP address on the computer.

Set the IP addresses on the computer. The default IP addresses of the Reader/Writer are given in the following table. Use these addresses to set the IP address on the computer. This example changes the last part of the IP address to a value other than 200 (i.e., to 1 to 199 or 201 to 254). Values of 0 and 255 cannot be used.

▪ Default IP Addresses of the Reader/Writer

Setting	Default setting
IP address	192.168.1.200 (fixed setting)
Subnet mask	255.255.255.0 (fixed setting)
Default gateway	192.168.1.254 (fixed settings)

■ Setting the IP Address on the Computer with Windows 7 or Windows 10

1. Open the Control Panel, and select Network and Internet and then Network and Sharing Center.
2. Select Change adapter settings and then right-click Local Area Connection.
3. Right-click Local Area Connection and select Properties.
4. Select Internet Protocol Version 4 (TCP/IPv4) and then click the Properties Button.
5. Select the Use the following IP address Option, make the following settings, and then click the OK Button.
 - Host Device Setting Example
 - IP address : 192.168.1.100
 - Subnet mask : 255.255.255.0

 This example changes the last part of the IP address of the host device to a value other than 200 (i.e., 1 to 199 or 201 to 254). Values of 0 and 255 cannot be used.

CHECK!
6. Click the OK Button to close the Internet Protocol Version 4 (TCP/IPv4) Properties Dialog Box.

Setting the IP Address of the Reader/Writer from a Web Browser

1. Start the Web browser.

Enter the IP address of the Reader/Writer in the address field of the Web browser to display the Browser Operation Window. Enter `http://192.168.1.200` if you are using the default IP address.

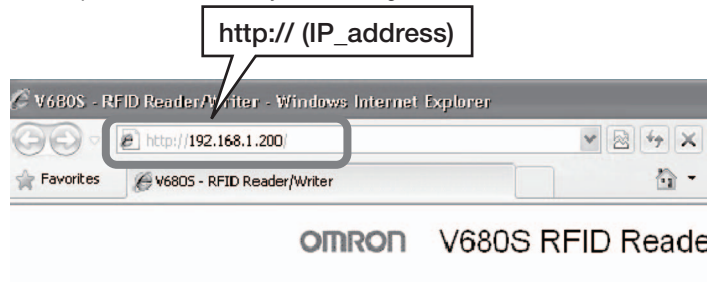

2. Set the IP address of the Reader/Writer.

Click the **Network settings** Button at the upper left of the Web Browser Operation Window.

Setting a Fixed IP Address

On the Network Settings View, select the *Fixed settings* Option, enter the IP address, subnet mask, and gateway address, and then click the **Set** Button.

English

Network settings

Fixed setting

IP address: 192.168.1.200

Subnet mask: 255.255.255.0

Gateway address: 192.168.1.254

Obtain from BOOTP server

Fix at the IP address which is obtained from BOOTP server

Web port: 7090

Web password: []

Device name: []

Set

configuration

▪ Getting an IP Address from a BOOTP Server

On the Network Settings View, select the *Obtain from BOOTP server* Option or the *Fix at the IP address which is obtained from BOOTP server* Option, and then click the **Set** Button.

English

Status

Network settings

Communication settings

Multi Reader/Writer setting

RF Tag communications

Log view

Noise monitor

RF Analyzer

Reboot

configuration

Network settings

Fixed setting

IP address 192.168.1.200

Subnet mask 255.255.255.0

Gateway address 192.168.1.254

Obtain from BOOTP server

Fix at the IP address which is obtained from BOOTP server

Web port 7090

Web password

Device name

Set



CHECK!

If you use the BOOTP client, the IP addresses that are used for the following Reader/Writer functions will change dynamically and may result in unexpected operation. Confirm that no problems will occur before you use the BOOTP client.

- IP address of the copy destination Reader/Writer for the data copy function
- IP addresses of the Slave Reader/Writers for multi-Reader/Writer operation

Setting the IP Address of the Reader/Writer on the Network Configurator

1. Start the Network Configurator.

To start the Network Configurator, select **All Programs – OMRON – Sysmac Studio – Network Configurator for EtherNet/IP – NetworkConfigurator** from the Windows Start Menu.

The following window will be displayed when the Network Configurator starts.

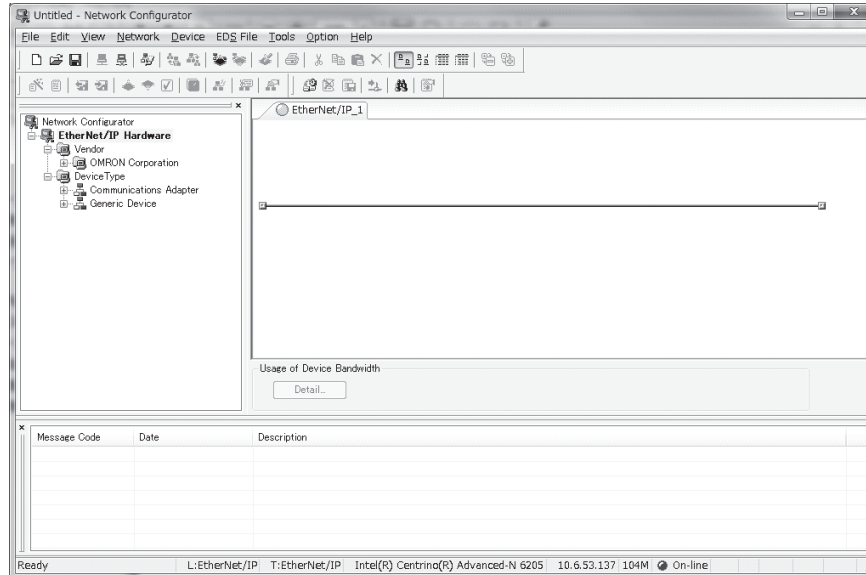

2. Go online with the network.

Here, the Network Configurator is placed online through Ethernet.

Select **Network – Connect**.

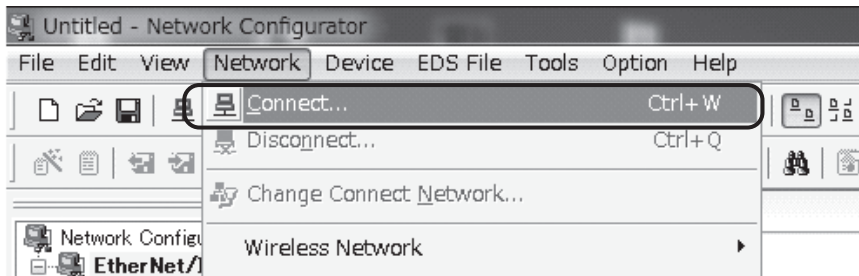

3. Set the IP address of the Reader/Writer.

Select **Tools – Setup TCP/IP Configuration** to open the Setup TCP/IP Configuration Dialog Box.

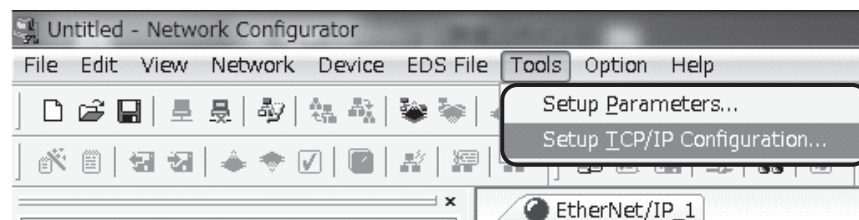

Enter the default IP address of the Reader/Writer (192.168.1.200) in the *Target IP Address* Box.

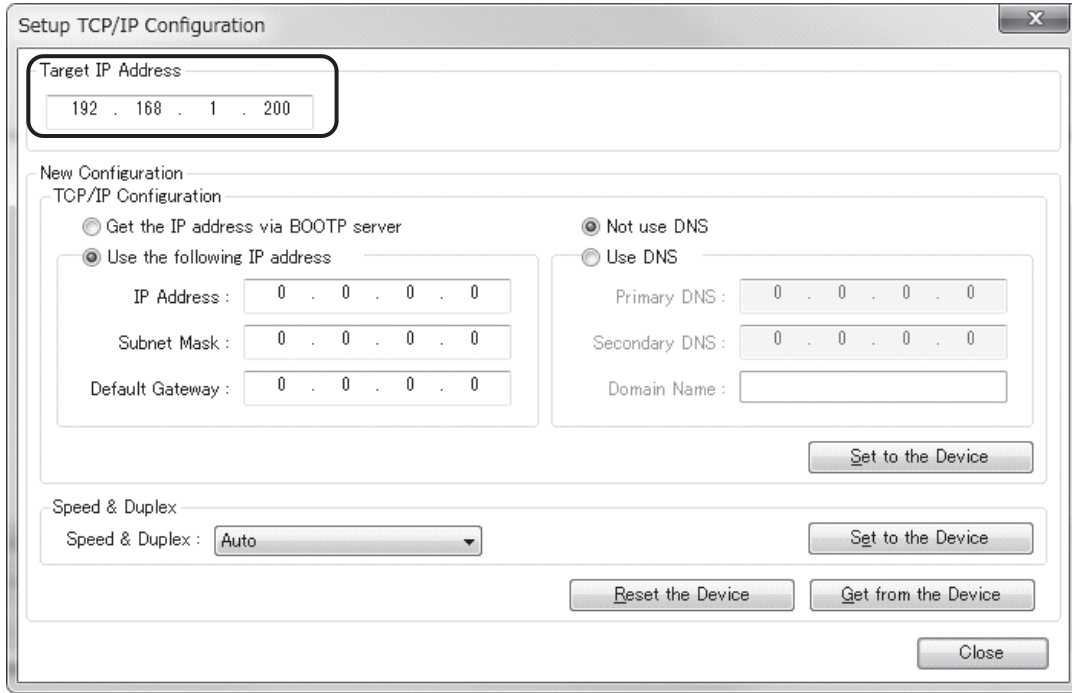

■ Setting a Fixed IP Address

1. Enter the IP address, subnet mask, and default gateway.
2. Click the **Set to the Device** Button.
3. Click the **Reset the Device** Button to apply the IP address setting in the Reader/Writer.

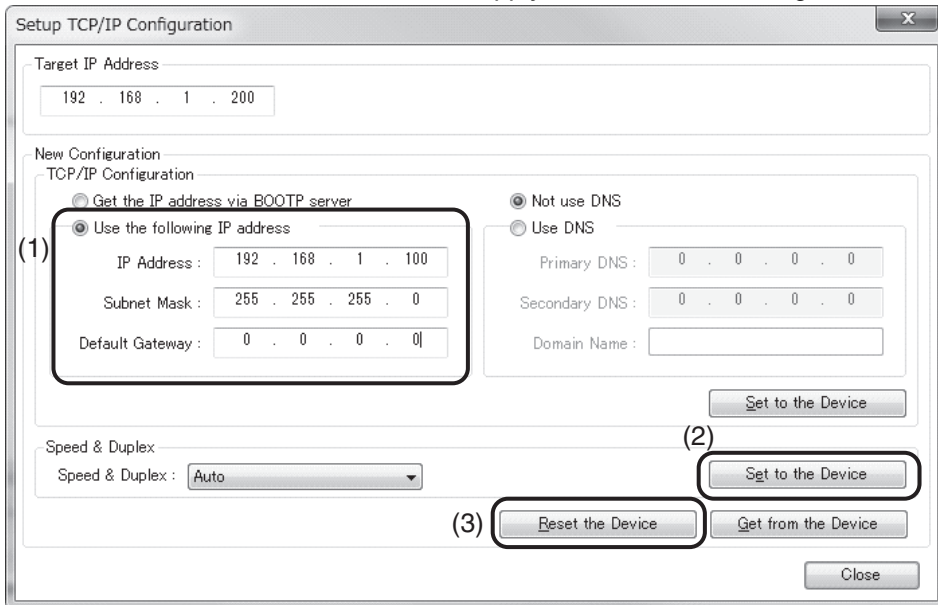

▪ **Getting an IP Address from a BOOTP Server**

1. Select the *Get the IP Address via BOOTP* server Option.
2. Click the **Set to the Device** Button.
3. Click the **Reset the Device** Button to apply the IP address setting in the Reader/Writer.

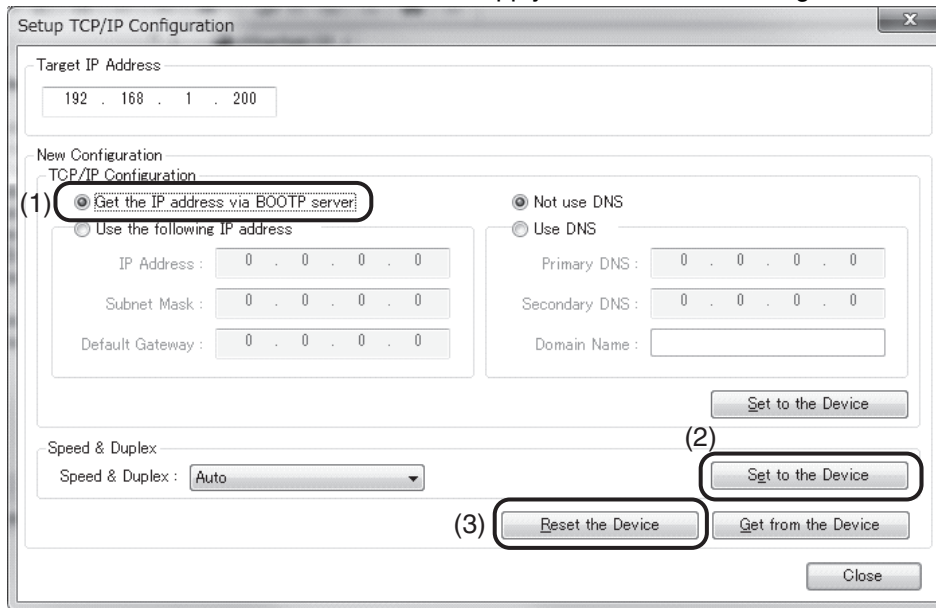

Setting Tag Data Links

Refer to *Section 7 Tag Data Link Setting Methods*.

 p.148

Section 6

Functions

☒	Operation Mode	92
	Run Mode	92
	Safe Mode	92
☒	RF Tag Communications	93
	Communications Options	93
	Normal RF Tag Communications	98
	Tag Memory Management	98
☒	Reader/Writer Controls	100
	RESET	100
☒	Maintenance	101
	Reading Device Information	101
	Noise Measurement	101
☒	Setting Functions	102
	Initialization	102
	Setting Communications Conditions	103
	Network Settings	105
☒	Error Logs	106
	System Error Log	106
	Command Error Log	106
☒	Web Server	107
	Status Monitoring, Setting, and Confirmation	107
	Convenient Functions	107
☒	RFID System Maintenance	108
	Communication Diagnostic	108
	RF Analyzer	111
☒	Multi-Reader/Writer Operation	113
	Field Extension Mode	115
	High-speed Traveling Mode	116
☒	Using Multi-Reader/Writer Operation	124
	Using the Web Server	118
☒	Using Multi-Reader/Writer Operation	124
	Using Field Extension Mode	124
	Using High-speed Traveling Mode	135

Operation Mode

The Reader/Writer has two operation modes: Run Mode and Safe Mode.

You can use the control signal to the Reader/Writer connector to change between these modes.

Run Mode

When you connect the control signal to the 24-VDC side of the power supply and turn ON the power supply, the Reader/Writer will start in Run Mode.

Operation is performed in the modes specified in the commands from the host device and the results are returned to the host device as responses.

Safe Mode

When you connect the control signal to the 0-VDC side of the power supply and turn ON the power supply, the Reader/Writer will start in Safe Mode. The Safe Mode is used when you do not remember the IP address that is set in the Reader/Writer. In Safe Mode, the Reader/Writer will start with the following IP settings.

IP address: 192.168.1.200

Subnet mask: 255.255.255.0

RF Tag Communications

Communications Options

Communications with the RF Tag are performed according to one of the communications options that are listed in the following table.

The setting of the communications option is effective immediately after it is changed. It is saved in internal memory in the Reader/Writer even after the power supply is turned OFF.

Name	Description
Once	When the Reader/Writer receives a command, it communicates with an RF Tag and returns a response.
Auto	After the Reader/Writer receives a command, the Reader/Writer automatically detects an RF Tag that enters the communications field and communicates with it. Communication can be carried out without confirming the existence of an RF tag by a sensor or the like.
Repeat	When the Reader/Writer receives a command, it repeatedly communicates with RF Tags and returns a response when communicating with an RF Tag was possible. Until the Reader/Writer communicates with another RF tag, the Reader/Writer cannot communicate with the RF tag once communicated.
FIFO Repeat	<p>When the Reader/Writer receives a command, it repeatedly communicates with RF Tags and returns a response when communicating with an RF Tag was possible.</p> <p>The Reader/Writer can communicate with the another RF tag when the new RF tag comes in the communication area, because the Reader/Writer stops the operation of the RF tag once communicated.</p> <p>The Reader/Writer does not communicate with the RF tag once communicated until the following conditions are satisfied.</p> <ul style="list-style-type: none"> •The RF tag goes out of the communication area. •The Reader/Writer communicates with another RF tag. <p>FIFO Repeat has the following two setting modes.</p> <ul style="list-style-type: none"> •Without ID code check Repeat communication with RF tags without ID code check. Compared “With ID code check”, communication time becomes shorter. However, if the next tag enters the communication area during communication processing with the RF tag, there is a possibility of reading the data of the next RF tag. It is the same communication function as the FIFO repeat of the Reader/Writer of firmware version “3.01 or earlier”. •With ID code check Repeat Communication with RF tag is processed with ID code check. Even if the next tag enters the communication area during communication processing with the RF tag, it will not read the data of the next RF tag. RF tags can be installed at narrow pitch. However, compared with “Without ID code check”, communication time will be longer. Therefore, in order to ensure reliable communication with the RF tag you want to communicate, we recommend “With ID code check”. It can be used with a Reader/Writer with firmware version “3.02 or later”.



“ID code” is a unique ID previously stored in each RF tag. By performing ID code check, even if an RF tag with another ID code enters the communication area during communication processing, it does not communicate with that RF tag.

CHECK!

Refer to *RF Tag Communications Time (for Reference Only)* in Section 11 Appendices for details of Communications Time.



p.250

■ **Once**

The Reader/Writer communicates with RF Tags for command execution requests from the host device. When the Reader/Writer is finished communicating with an RF Tag, it returns the communications results to the host device and waits for another command.

If there is no RF Tag in the communications field when the Reader/Writer receives the command from the host device, an RF Tag missing error will occur. It is therefore necessary to use a sensor or other device to detect the presence of an RF Tag before you request command execution.

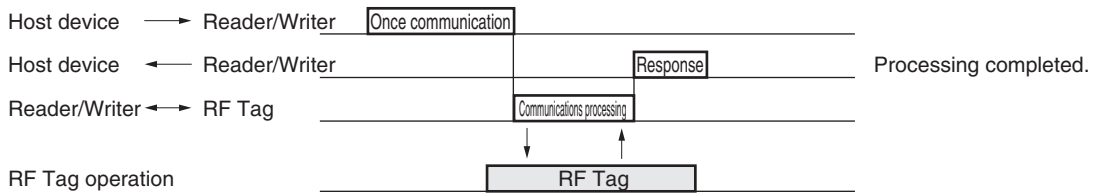
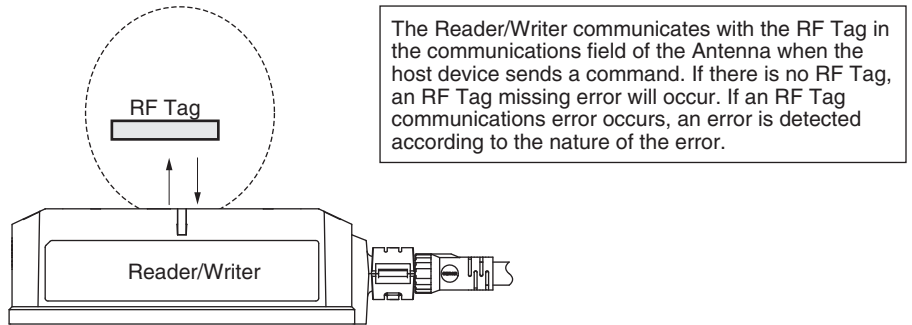

Refer to *Time Charts in Section 7 Host Communications Specifications* for details of Time charts of each communications options.

p.182

■ **Auto**

The Reader/Writer automatically detects an RF Tag and communicates with it.

After the host device sends the command, the Reader/Writer automatically detects an RF Tag that enters the communications field and communicates with it.

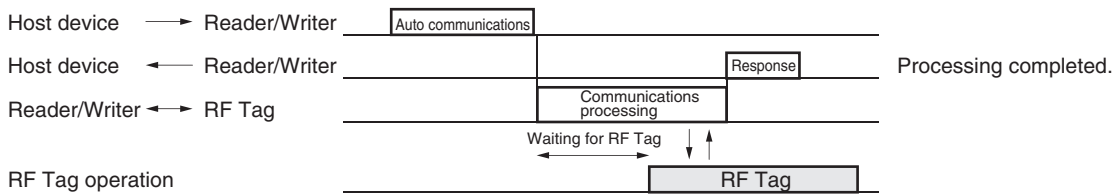
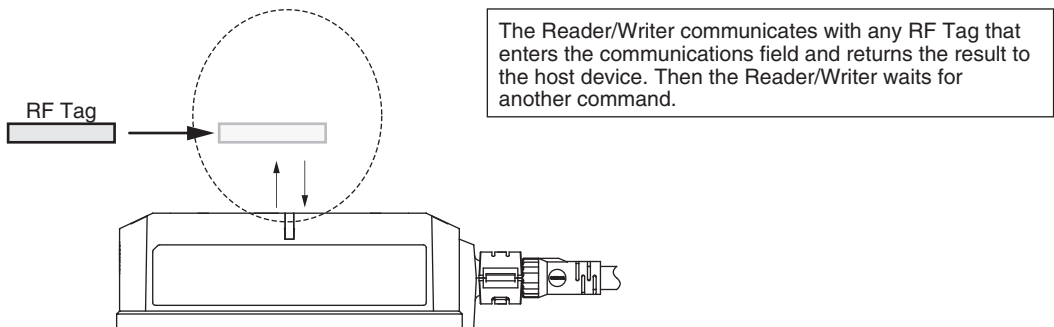

Refer to *Time Charts in Section 7 Host Communications Specifications* for details of Time charts of each communications options.

p.183

Repeat

When the Reader/Writer receives a command execution request from the host device, it automatically detects RF Tags in the communications field and communicates with them. This process is repeated until the execution request is cleared.

Communications are not performed for RF Tags that have returned communications results to the host device until the Reader/Writer has to communicate with another RF Tags.

You can use this specification to perform communications with RF Tags in order as they move past the Reader/Writer. However, if there is more than one RF Tag in the communications field of the Antenna at the same time, normal communications will not be possible. Make sure that there is never more than one RF Tag in the communications field of the Antenna at the same time.

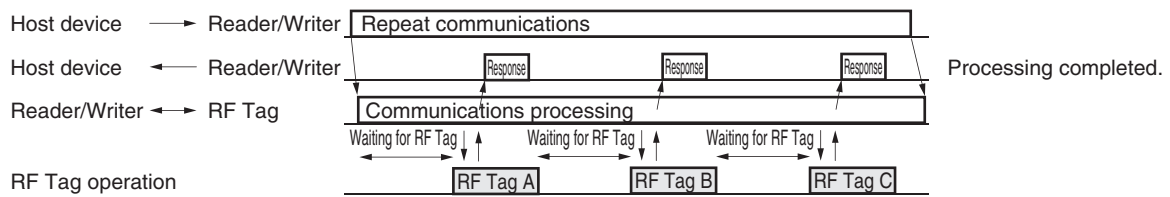
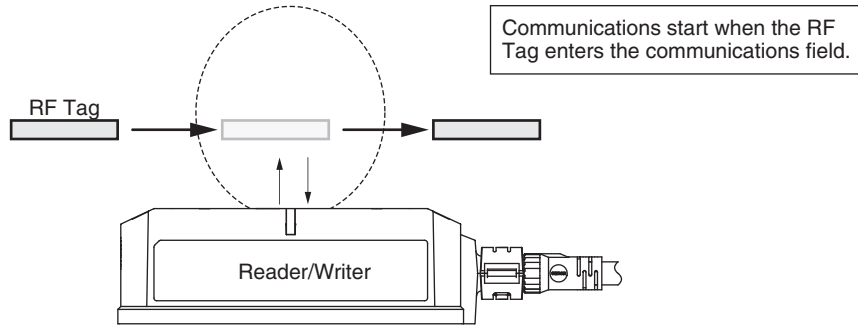

When the communications option is "Repeat", no notice (error response) is sent to the host device even if an RF Tag missing error or communications error occurs.

CHECK!

Refer to *Time Charts* in *Section 7 Host Communications Specifications* for details of Time charts of each communications options.

p.184

■ FIFO Repeat

When the Reader/Writer receives a command execution request from the host device, it automatically detects RF Tags in the communications field and communicates with them. After successfully communicating with an RF Tag once, operation for that RF Tag is stopped. This process is repeated until the execution request is cleared. The Reader/Writer does not communicate with the RF tag that has completed communication until the RF tag is out of the communication area.

The Reader/Writer does not communicate with the RF tag once communicated until the following conditions are satisfied.

- The RF tag goes out of the communication area.
- The Reader/Writer communicates with another RF tag.

You can use the FIFO Repeat communications option to perform communications with RF Tags in order as they move past the Reader/Writer even when there is limited space between the RF Tags. If there is more than one RF Tag for which operation is possible in the communications field of the Antenna at the same time, normal communications will not be possible. Make sure that there is never more than one RF Tag for which operation is possible in the communications field of the Antenna at the same time.

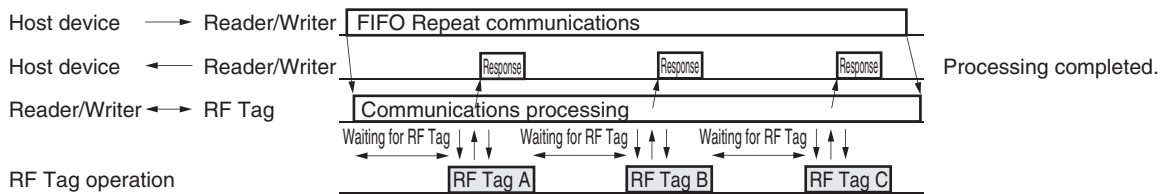
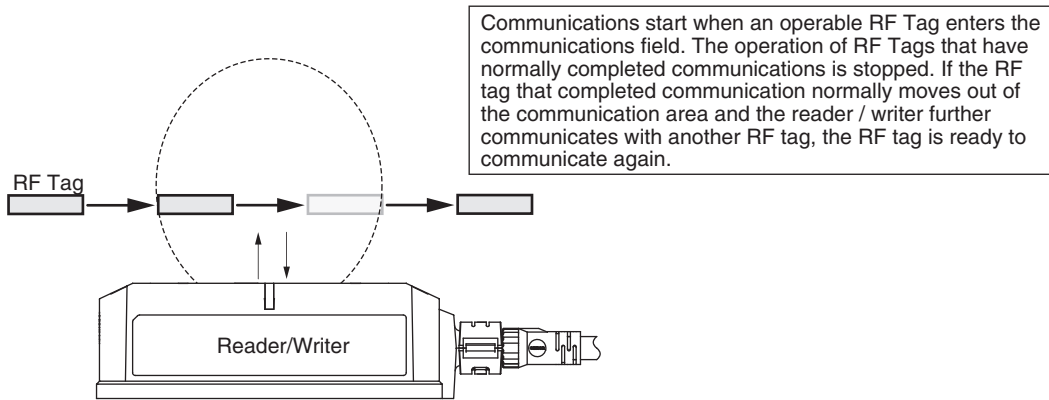

FIFO Repeat communications cannot be used for communicating with V680-D1KP□□ RF Tags.

CHECK!



When the communications option is "FIFO Repeat", no notice (error response) is sent to the host device even if an RF Tag missing error or communications error occurs.

CHECK!

Refer to *Time Charts* in *Section 7 Host Communications Specifications* for details of Time charts of each communications options.



p.184

The FIFO Repeat detects the RF tag in the sequence of “1. RF tag detection processing” and executes read/write with the RF tag detected in the sequence of “2. communication processing”.

<Without ID code check>

When using FIFO Repeat (Without ID code check), please do not put the next RF tag B in the communication area until communication with the detected RF tag is completed. (See the figure below) *

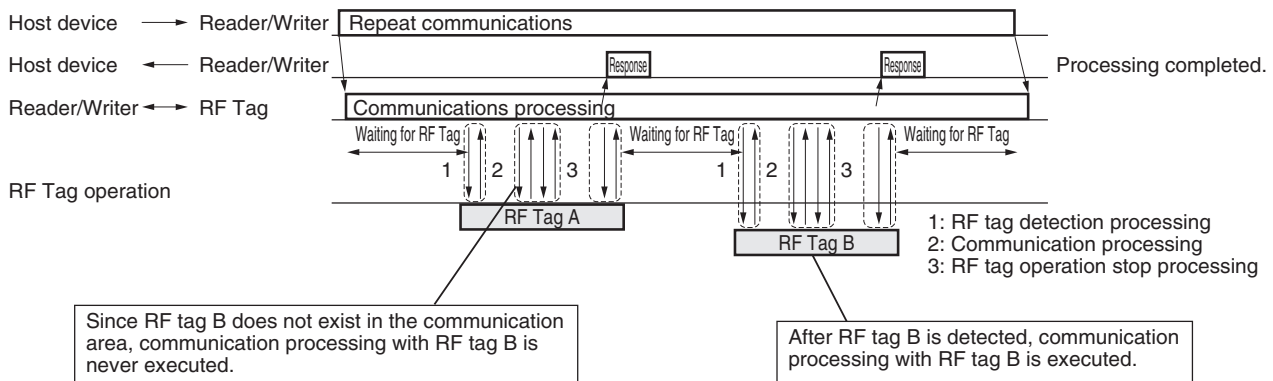

* When using FIFO Repeat (Without ID code check), the ID code of the RF tag is not checked. Therefore communication time will be shorter than FIFO Repeat (With ID code check). However, if the next RF tag enters the communication area during “2. communication processing” with the detected RF tag, there is a possibility of reading / writing the next RF tag.

<With ID code check>

When FIFO Repeat (With ID code check) is used, even if the next RF tag enters the communication area before communication with the detected RF tag is completed, it can read / write without any problem I will. *

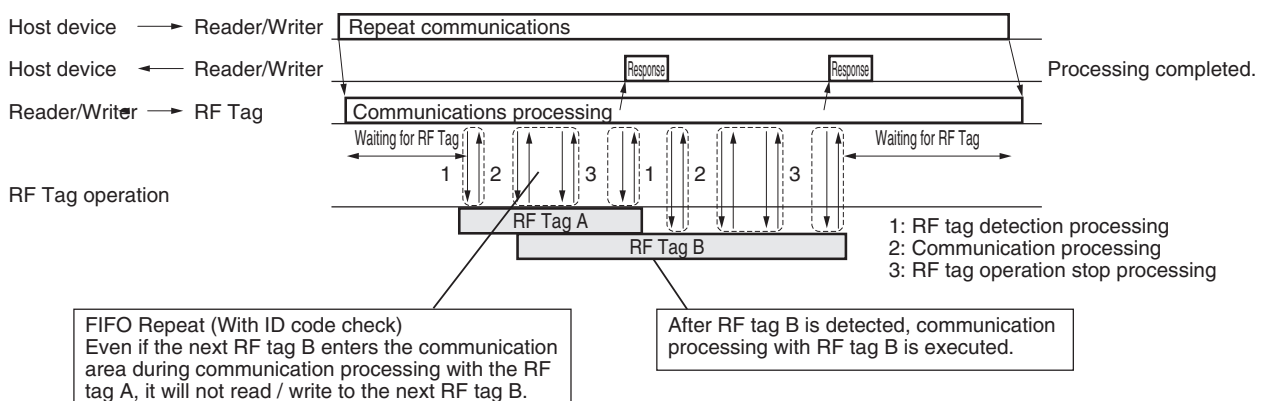

* When using FIFO Repeat (With ID code check), the ID code of the RF tag is checked. Even if the next RF tag enters the communication area during “2. communication processing” with the detected RF tag, there is no possibility of reading / writing the next RF tag. However, compared with “Without ID code check”, communication time will be longer.



“ID code” is a unique ID previously stored in each RF tag. By performing ID code check, even if an RF tag with another ID code enters the communication area during communication processing, it does not communicate with that RF tag.

Refer to *RF Tag Communications Time (for Reference Only)* in *Section 11 Appendices* for details of Communications Time.

p.250

Normal RF Tag Communications

The commands in the following table perform communications with RF Tags.

Name	Description	Page
READ DATA	Reads data from an RF Tag.	p.157
WRITE DATA	Writes data to the memory of the RF Tag.	p.158
READ ID	Reads the RF Tag's ID code.	p.156
DATA FILL	Writes the specified data to the specified number of words beginning from the specified start address. The specifications are made in the command.	p.160
LOCK	Locks the specified memory block in the RF Tag. It will no longer be possible to write data to the locked memory block. The lock cannot be released.	p.159
COPY DATA	Reads data from the memory of an RF Tag using one Reader/Writer (A) and writes it to the memory of the RF Tag in the communications field of another Reader/Writer (B).	p.163

Tag Memory Management

RF TAG OVERWRITE COUNT CONTROL Command

The RF TAG OVERWRITE COUNT CONTROL command is used to determine whether the RF Tag overwrite limit has been exceeded.

- With the RF TAG OVERWRITE COUNT CONTROL command with a subtraction specification, the overwrite count is subtracted from the data in the user-specified overwrite count control area to determine whether the number of overwrites has been exceeded.
- With the RF TAG OVERWRITE COUNT CONTROL command with an addition specification, the overwrite count is added to the data in the user-specified overwrite count control area to determine whether the number of overwrites has exceeded 100,000. The RF TAG OVERWRITE COUNT CONTROL command with an addition specification is used only for RF Tags with a overwrite life of 100,000 writes.

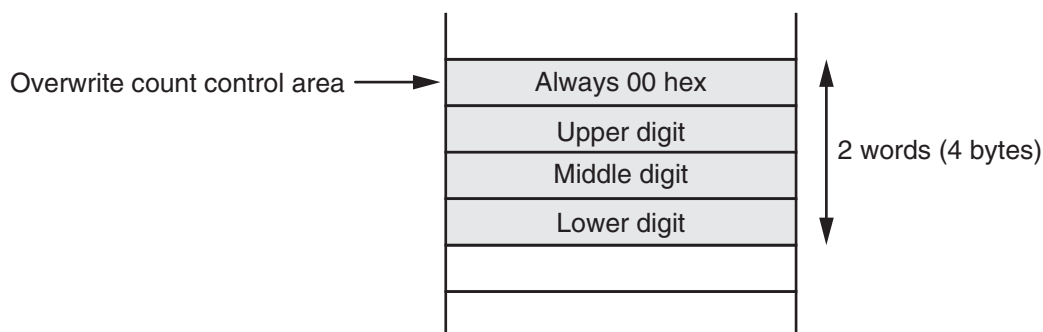

RF TAG OVERWRITE COUNT CONTROL Command with a Subtraction Specification

The overwrite count control area consists of 4 bytes from the specified start address. The decrement value is subtracted from the overwrite count and then written to this area. When the value reaches 0 (i.e., 00 hex), a warning code is returned. Therefore, to enable control of the number of overwrites, the maximum number of overwrites must be written to the overwrite count control area beforehand. You can set any number of overwrites up to 16,700,000.

You can read the overwrite count control area with a read command. If the control area data is already 0, the control area value will not be refreshed, and a warning code will be returned as a response. When the refresh count is set to 0000 hex, the count will not be updated, and only an overwrite count check will be performed.

RF TAG OVERWRITE COUNT CONTROL Command with a Addition Specification

The overwrite count control area consists of 4 bytes from the specified start address. The increment value is added to the overwrite count and then written to this area. When the value reaches 100,000 (i.e., 0186A0 hex), a warning code is returned. You can read the overwrite count control area with a read command. If the control area data is already 100,000, the control area value will not be refreshed, and a warning code will be returned as a response. When the refresh count is set to 0000 hex, the count will not be updated, and only an overwrite count check will be performed.

Reader/Writer Controls

RESET

You can restart the Reader/Writer.

You can restart the Reader/Writer by using a RESET command or by using a CIP message (specifically, by issuing the Reset service to the Identity object) from a Web browser. The Reader/Writer will return the execution results and reset itself.

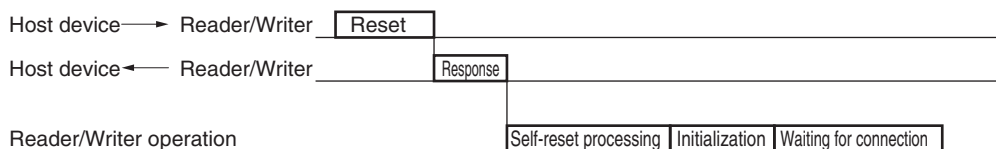

If you reset the Reader/Writer during tag data link communications, the connection will be broken and must be re-established from the originator.

CHECK!

Maintenance

Reading Device Information

You can read the device information given in the following table from the Reader/Writer. You can send a command from the host device or access the information from a Web browser to read the device information.

Device information	Description
Model	Gives the model number of the Reader/Writer.
Firmware version	Gives the firmware version in the Reader/Writer.
MAC address	Gives the MAC address that is assigned to the Reader/Writer. * Not supported for the command.
Reader/Writer operating status	Gives the operating status of the Reader/Writer. The operating status include idle (waiting for a command), communicating, other processing, etc. * Not supported for the command.
Operating time	Gives the elapsed time in milliseconds since the Reader/Writer was started. * 0 to 4,294,967,295 (FFFF FFFF hex)

Noise Measurement

Communication performance will be reduced when the RF tag or the Reader/Writer are influenced by ambient noise. The Reader/Writer responds the ambient noise level by using noise monitor function. The response data includes the following parameters. By checking the noise level, you can check the influence on the performance of communication with the RF tag in advance. You can also check the noise level when the trouble occurs.

Noise level (Average)	This represents the average value of the measured noise level. 00 to 99
Noise level (Maximum)	This represents the Maximum value of the measured noise level. 00 to 99
Noise level (Minimum)	This represents the minimum value of the measured noise level. 00 to 99

The noise monitor can be performed by means of the following two.

Measuring Noise with a Command from the Host Device

You can send the MEASURE NOISE command to the Reader/Writer to obtain the numerical ambient noise level around the Reader/Writer.

Refer to *MEASURE NOISE* in *V680S Command Details* in *Section 7 Host Communications Specifications* for details on the MEASURE NOISE command.



p.175

Noise measurement using Web browser.

You can check the transition graph of the noise level using WEB browser.

By selecting the type of the RF tag, you are also able to visually confirm the stability of communication.

Refer to *Noise Monitor View* in *Section 8 Browser Interface* for more information.



p.197

If the noise level that was confirmed by WEB browser screen may affect the performance of communication, do the following actions.

- If the other Reader/Writers are operating close to the Reader/Writer, ensure the distance between the Reader/Writers.



p.254, p.255, p.257

- If the equipment close to the Reader/Writer, become a source of noise transceivers, motors, inverters, and switching power supply is running, ensure the distance until the amount of noise is sufficiently reduced. Take action, such as enclosing the noise source by metal object.

Setting Functions

You can use a setting command or a Web browser to set the operating conditions of the Reader/Writer according to the application environment.

You can save the settings so that they are stored in internal memory in the Reader/Writer even after the power supply is turned OFF.

Only the settings that are made with the SET TAG COMMUNICATIONS CONDITIONS command are effective immediately after they are changed. For any changes to all other settings, you must first save them and then reset the Reader/Writer to enable using them.

Refer to *SET MULTI-READER/WRITE OPERATION* in *V680S Command Details* in *Section 7* the setting command.



p.168

Refer to *RF Tag Communications View* and *Network Settings View* in *Section 8 Browser Interface* for the setting procedure for the web browser interface.



p.192, p.195

Initialization

Initialization returns all of the set values in the Reader/Writer to their default values.

Setting Communications Conditions

This command sets parameters that are related to the operation of communications with RF Tags. Any changes to the settings that are made with this command are effective immediately. (There is no need to reset the Reader/Writer to save the settings.)

■ Communications Option Setting

You can set the communications option of the Reader/Writer to Once, Repeat, or FIFO Repeat.

Name	Description
Once	When the Reader/Writer receives a command, it communicates with an RF Tag and returns a response.
Auto	After the Reader/Writer receives a command, the Reader/Writer automatically detects an RF Tag that enters the communications field and communicates with it. Communication can be carried out without confirming the existence of an RF tag by a sensor or the like.
Repeat	When the Reader/Writer receives a command, it repeatedly communicates with RF Tags and returns a response when communicating with an RF Tag was possible. Until the Reader/Writer communicates with another RF tag, the Reader/Writer cannot communicate with the RF tag once communicated.
FIFO Repeat	<p>When the Reader/Writer receives a command, it repeatedly communicates with RF Tags and returns a response when communicating with an RF Tag was possible.</p> <p>The Reader/Writer can communicate with the another RF tag when the new RF tag comes in the communication area, because the Reader/Writer stops the operation of the RF tag once communicated.</p> <p>The Reader/Writer does not communicate with the RF tag once communicated until the following conditions are satisfied.</p> <ul style="list-style-type: none"> •The RF tag goes out of the communication area. •The Reader/Writer communicates with another RF tag. <p>FIFO Repeat has the following two setting modes.</p> <ul style="list-style-type: none"> •Without ID code check Repeat communication with RF tags without ID code check. Compared “With ID code check”, communication time becomes shorter. However, if the next tag enters the communication area during communication processing with the RF tag, there is a possibility of reading the data of the next RF tag. It is the same communication function as the FIFO repeat of the Reader/Writer of firmware version “3.01 or earlier”. •With ID code check Repeat Communication with RF tag is processed with ID code check. Even if the next tag enters the communication area during communication processing with the RF tag, it will not read the data of the next RF tag. RF tags can be installed at narrow pitch. However, compared with “Without ID code check”, communication time will be longer. Therefore, in order to ensure reliable communication with the RF tag you want to communicate, we recommend “With ID code check”. It can be used with a Reader/Writer with firmware version “3.02 or later”.



CHECK!

“ID code” is a unique ID previously stored in each RF tag. By performing ID code check, even if an RF tag with another ID code enters the communication area during communication processing, it does not communicate with that RF tag.

Refer to *RF Tag Communications Time (for Reference Only)* in Section 11 Appendices for details of Communications Time.



p.250

■ RF Tag Communications Speed Setting

You can set the speed for communications between the Reader/Writer and RF Tags.

High speed (default)	This setting reduces the communications time by reading more than one block at the same time with an air interface. However, if errors are detected during communications due to ambient noise or other factors, processing is redone from the beginning, which can actually increase the communications time.
Normal speed	This setting provides more stable communications quality by reading one block at a time, in the same way as for the earlier V680. Although the normal communications time is longer, processing can be continued during communications if errors are detected due to ambient noise or other factors, which can actually reduce the communications time.

■ Write Verification

You can set whether to verify write processing.

Enabled (default)	After processing a write operation, the memory area that was written in the RF Tag is read and verified to confirm that the write operation was performed normally.
Disabled	Write processing is not verified.

■ Communications Diagnostic

You can set whether to the communications diagnostic of the Reader/Writer.

Disable (default)	The Reader/Writer does not perform communications diagnostic.
Enable	This function diagnoses the communications leeway whenever the Reader/Writer communicates with an RF Tag, displays the results on an operation indicator, and reports the results to the host device. It will help you achieve a more stable Reader/Writer and RF Tag installation and enable monitoring the status of operations.

Network Settings

You can set the parameters for communications between the Reader/Writer and the host device. If you change the settings, you must reset the Reader/Writer to enable the new settings.

■ IP Address, Subnet Mask, and Default Gateway

You can use any of the following methods to set the IP address, subnet mask, and default gateway for the Reader/Writer.

Setting method	Description
Fixed settings	You can set the IP address, subnet mask, and default gateway as required. The default settings are as follows: IP address: 192.168.1.200 Subnet mask: 255.255.255.0 Default gateway: 192.168.1.254
Obtain from BOOTP server	The IP address, subnet mask, and default gateway are obtained from the BOOTP server every time the power supply is turned ON.
Obtain from BOOTP server as fixed settings	The IP address, subnet mask, and default gateway are obtained from the BOOTP server when the power supply is turned ON and then they are used as fixed settings whenever the Reader/Writer is started after that.

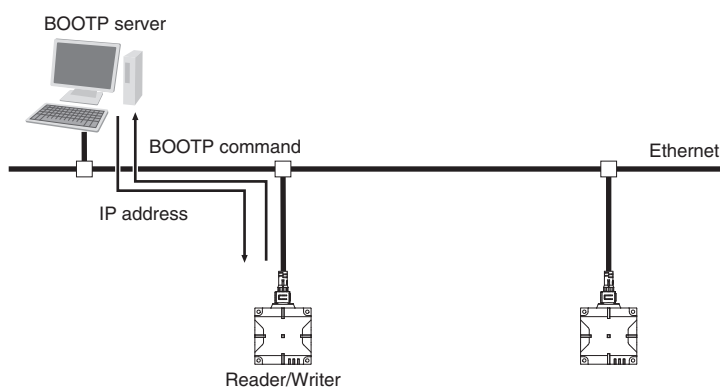

CHECK!

If you select *Obtain from BOOTP server as fixed settings*, the settings will automatically be changed to fixed settings after the IP address is obtained from the BOOTP server.



CHECK!

To stop obtaining the settings from the BOOTP server, select fixed settings and then manually set the IP address, subnet mask, and gateway address.



CHECK!

If you use multi-Reader/Writer operation, do not change the IP address of a slave Reader/Writer directly. To change it, change the multi-Reader/Writer settings on the master Reader/Writer.

■ Setting the Web Password

You can set a password for logging in from a Web interface. The password can be up to 15 ASCII characters. No password is set by default.

If a Web password is set, a dialog box requesting entry of the password will be displayed when the initial Web server interface is displayed. If the correct password is entered, the normal Web interface can be used.

Error Logs

The Reader/Writer manages errors that occur during operation in logs. The error logs are saved until the power supply to the Reader/Writer is turned OFF. You can read the error logs by sending commands from the host device or by using a browser.

The following logs are saved.

Category	Description
System error log	This log contains up to eight fatal errors that were detected by the Reader/Writer. They are given in chronological order. If more than eight system errors occur, the oldest records are deleted in order.
Command error log	This log contains up to 16 errors detected for command execution for tag data links. They are given in chronological order. If more than 16 errors occur, the oldest errors are deleted in order.

System Error Log

Each record in the system error log consists of 16 bytes in the format that is shown in the following table. Up to eight records are recorded. To read the system error log, either send a GET SYSTEM ERROR LOG command or read it from a browser.

Field	Size	Description
Operating time	4 bytes	This is the operating time of the Reader/Writer when the error occurred. * The operating time is the elapsed time in milliseconds from when the Reader/Writer was started.
Error code	4 bytes	This code is used to identify the error.
Attached information 1	4 bytes	These codes provide additional information on the error.
Attached information 2	4 bytes	

Refer to *Error Codes* in *Section 7 Host Communications Specifications* for detailed information on error codes, attached information 1, and attached information 2.



p.153

Command Error Log

Each record consists of 16 bytes in the format that is shown in the following table. Up to 16 records are recorded. To read the command error log, either send a GET COMMAND ERROR LOG command or read it from a browser.

Field	Size	Description
Operating time	4 bytes	Gives the operating time of the Reader/Writer when the error occurred. * The operating time is the elapsed time in milliseconds from when the Reader/Writer was started.
IP address of device that sent the command	4 bytes	Gives the IP address of the host device that sent the command.
Command code	2 bytes	Gives the command code of the command received by the Reader/Writer.
Error code	2 bytes	Gives the error code from the response returned by the Reader/Writer.
Response information 1	2 bytes	Gives response information 1 from the response returned by the Reader/Writer.
Response information 2	2 bytes	Gives response information 2 from the response returned by the Reader/Writer.



CHECK!

Errors that occur during RF Tag communications from a browser are not recorded in the command error log. Only errors that occur in command execution for tag data links are recorded.

Refer to *Error Codes*, *Device Information*, and *Communications Diagnostics Results* in *Section 7 Host Communications Specifications* for detailed information on error codes, response information 1, and response information 2.



p.153, p.154

Web Server

The following functions are provided in the Web server interface.

Status Monitoring, Setting, and Confirmation

■ Status Monitoring

You can monitor the status of the Reader/Writer. The Reader/Writer status includes the firmware versions, MAC address, network settings, operating status, and other status information.

■ Setting

You can set any of the settable parameters from the Web server interface. This includes the network settings, RF Tag communications settings, etc.

■ Importing and Exporting Settings

You can import and export the Reader/Writer setting information. You can store or view the configuration file on a computer. You can use importing to simplify setting up more than one Reader/Writer and you can use exporting to store and restore settings information as a countermeasure for problems.

Convenient Functions

■ Simple Operation Test

You can send commands from the Web server interface to operate the Reader/Writer without any special software.

■ Utilities

You can display the results of noise measurements or error log information.

RFID System Maintenance

Communications performance can be affected by environmental factors around the RFID System (including metal objects, the positional relationship between the Reader/Writer and RF Tags, and noise). You can use the RFID System maintenance functions to check the leeway in communications and achieve more stable device operation.

Refer to *GET FIRMWARE VERSION* in *Section 7 Host Communications Specifications* for the procedure to check the firmware version.

 p.173



You cannot use the maintenance functions if you are using the FIFO Repeat communications option.

CHECK!

Communication Diagnostic

This function diagnoses the communications leeway whenever the Reader/Writer communicates with an RF Tag, displays the results on an operation indicator, and reports the results to the host device. It will help you achieve a more stable Reader/Writer and RF Tag installation and enable monitoring the status of operations.

The operation indicator lights green for a stable communication, yellow for an unstable communication, and red for a communications error.

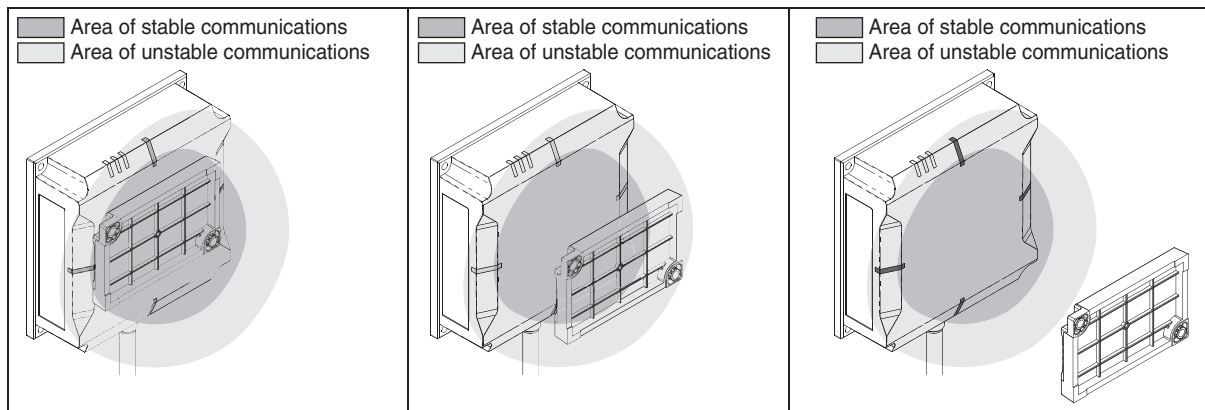

Yellow, which indicates an unstable communication, means that there is only 10% to 30% leeway in relation to the maximum communications range.

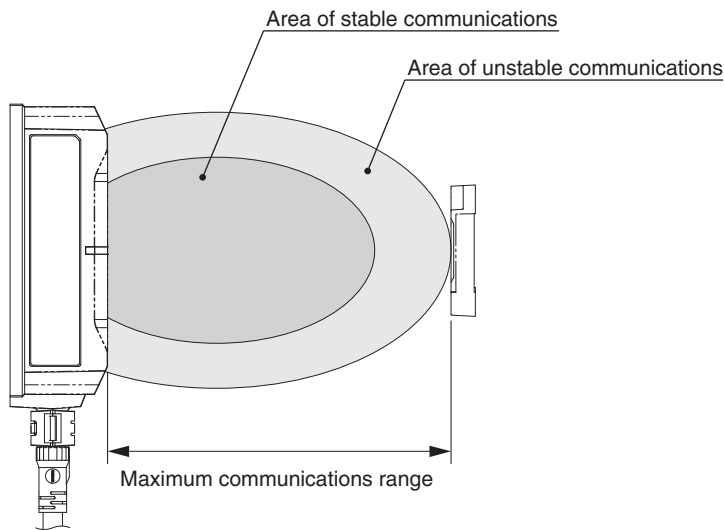



CHECK!

Communication diagnostic is disabled in the default settings. To use communication diagnostic, you must enable it in advance.

Refer to *RF Tag Communications View* in *Section 8 Browser Interface* for the setting procedure for communication diagnostic.



CHECK!

Use the results of communication diagnostic as a guideline.

An indication of a stable communication (green) does not necessarily mean that communications are normal.



CHECK!

Yellow, which indicates an unstable communication, does not necessarily mean that communications are not possible. It merely means that there is little leeway in communications.

If you want to ensure more stable communications, we recommend that you use the Reader/Writer so that stable communications (green) are indicated.



CHECK!

The communication time is approximately 200 ms longer when enabling Communication Diagnostic function.

You can use communication diagnostic to detect and diagnoses deterioration of performance for the following conditions.

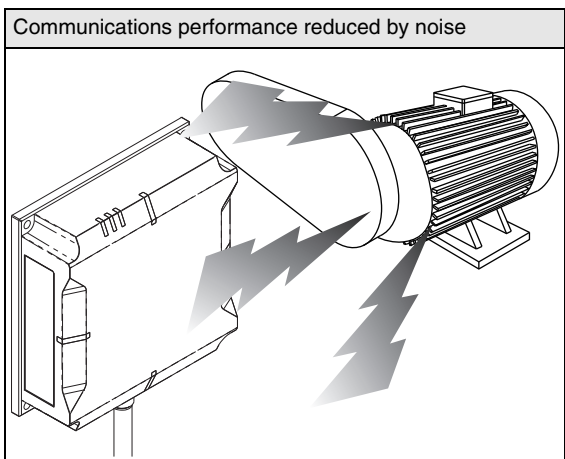
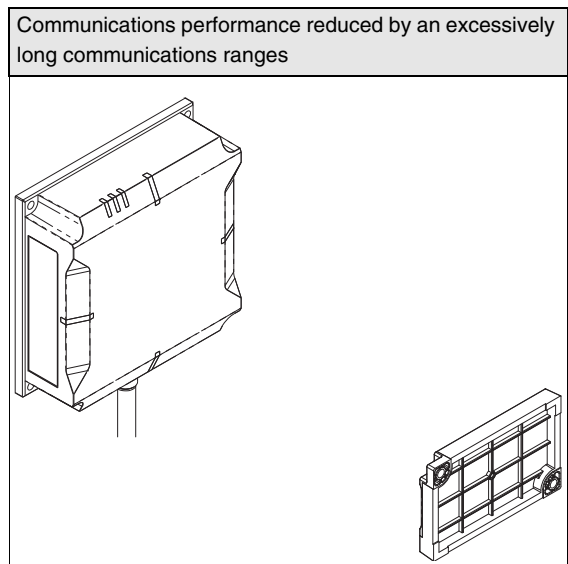
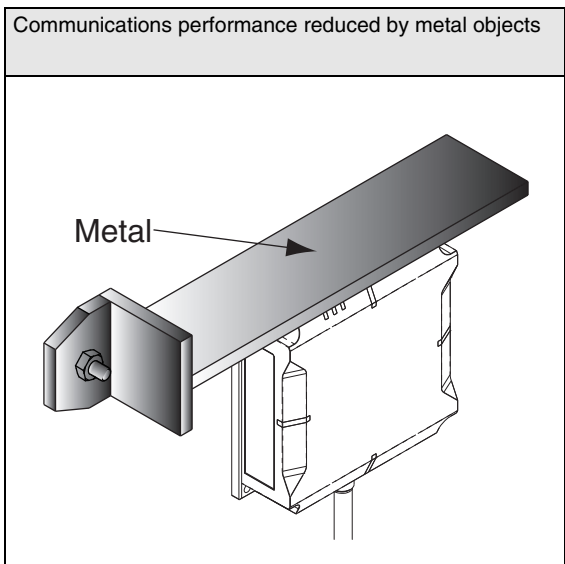
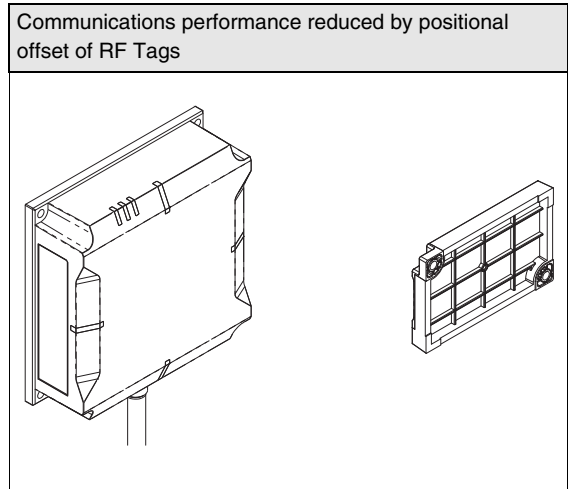
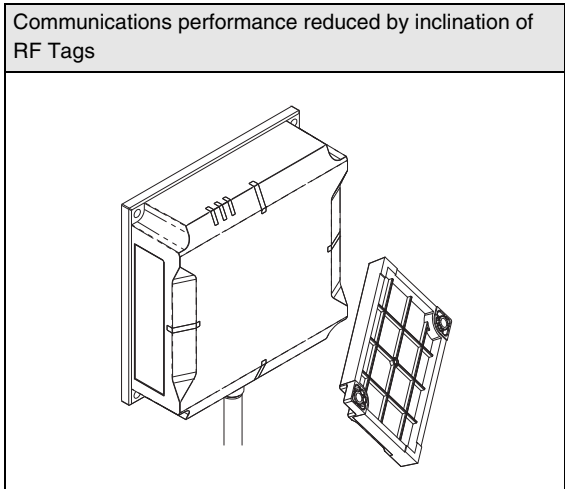

RF Analyzer

The RF Analyzer displays detailed information from communication diagnostic on a web browser. You can easily check to see how stable communications are and troubleshoot problems. You can browse a list of diagnostic information and periodically confirm the leeway quantitatively on graphs. You can download a log file that contains the diagnostic information stored in the Reader/Writer to a computer for your usage.

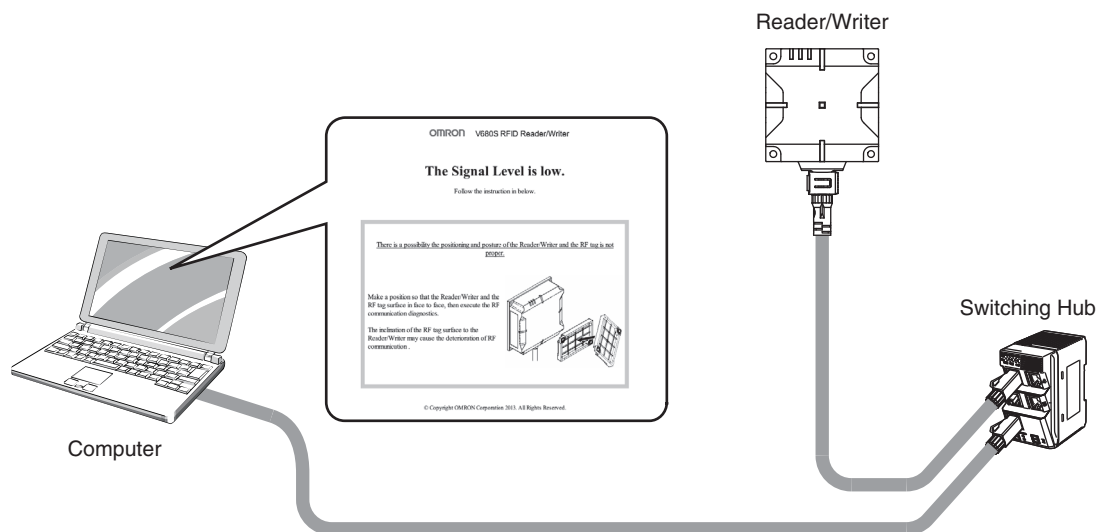

Diagnostic Information Table

You can display a table of the diagnostic information from communications between the Reader/Writer and RF Tags. (The table contains up to 2,048 records.) You can check the following items in the table.

Time	The Reader/Writer operating time when it communicated with the RF Tag
Command	The name of the command used to communicate with the RF Tag
Result	The diagnostic result (stable, unstable, or error)
Diagnostic information	The cause when a communication was unstable

Whenever a communication was unstable, a button to display details is displayed in the list. If you click this button, you can troubleshoot the cause with guidance displayed on the browser to help stabilize communications.

Diagnostic Information Graphs

You can display the diagnostic information quantitatively on a graph. You can check the following information on the graph.

Signal level	The communications signal level between the Reader/Writer and RF Tag is displayed in 10 levels on a vertical bar graph. The higher the value, the more stable the communications. A value of 10 means that communications are stable, and the bar is displayed in blue. A value of 1 to 9 means that communications are unstable, and the bar is displayed in yellow. A value of 0 indicates a communications error. Adjust the installation conditions to get the values as close to 10 as possible.
Noise level	The ambient noise level around the Reader/Writer that was detected in communications with RF Tags is displayed in 10 levels on a broken-line graph. The higher the value, the less stable the communications.

Refer to *RF Analyzer* in *Section 8 Browser Interface* for the operating procedures of the RF Analyzer.

p.198

An application example of the RFID System maintenance functions is given below.

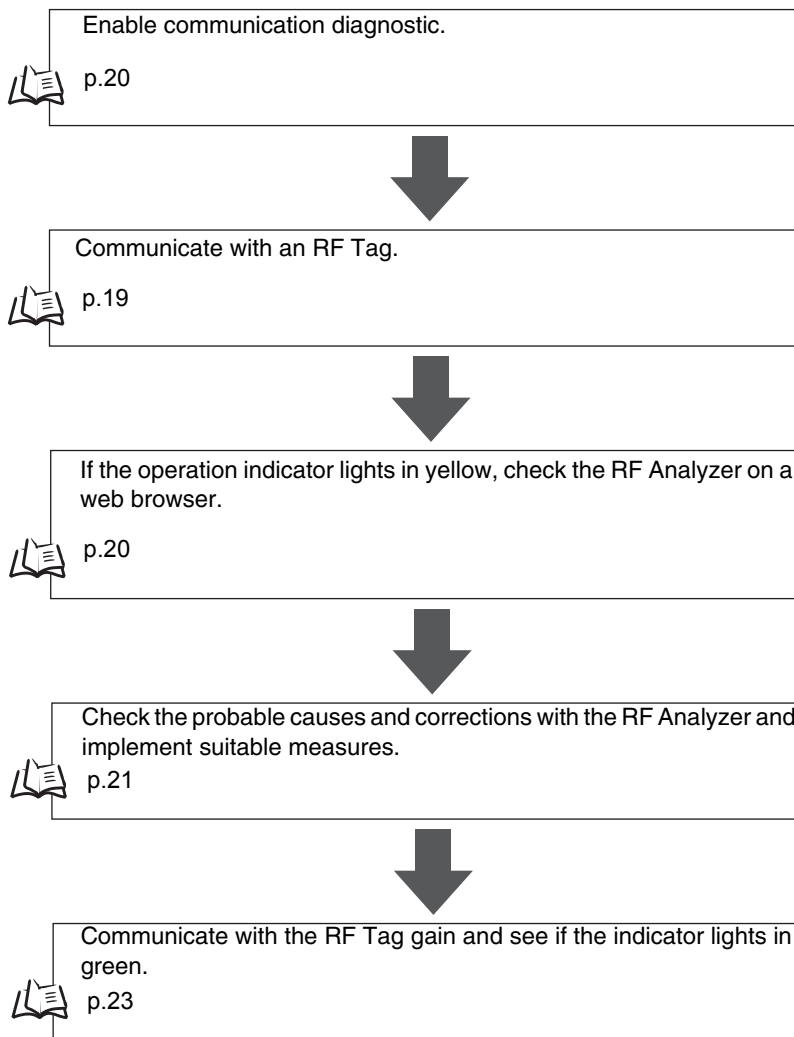

Multi-Reader/Writer Operation

There are two modes that you can use for multi-Reader/Writer operation: Field Extension Mode and High-speed Traveling Mode.

You can link up to eight Reader/Writers to perform communications operations with RF Tags. One of the Reader/Writers operates as the master and the other Reader/Writers operate as slaves.

The host device just has to control one Reader/Writer, the master, to easily achieve complex control operations for all of the linked Reader/Writers.

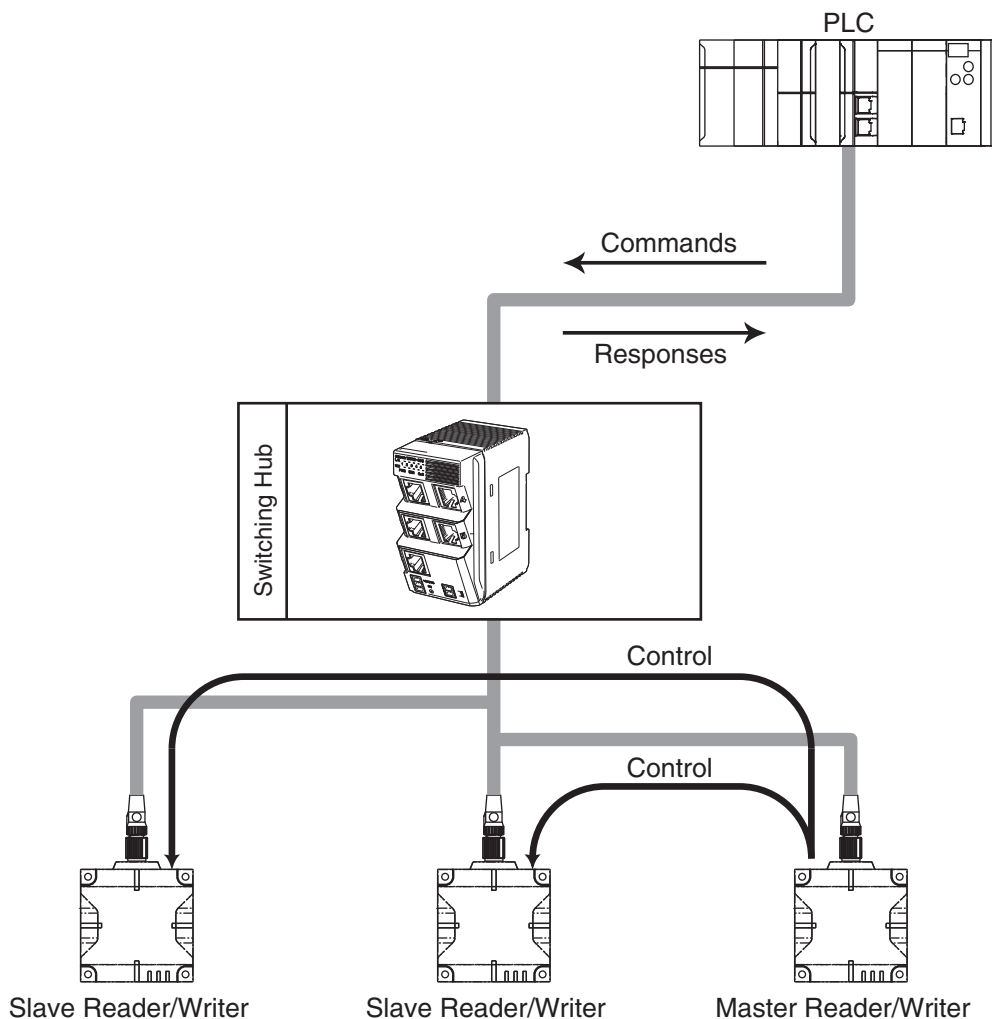

The RF Tag communications commands that you can use during multi-Reader/Writer operation (Field Extension Mode or High-speed Traveling Mode) are shown in the following table. If you use unsupported RF Tag communications commands when multi-Reader/Writer operation is enabled, an execution status error will be indicated in the response.

	Field Extension Mode	High-speed Traveling Mode
READ DATA	Supported	Supported
WRITE DATA	Supported	Not supported
DATA FILL	Not supported	Not supported
RF TAG OVERWRITE COUNT CONTROL	Not supported	Not supported
READ ID	Supported	Not supported
COPY	Not supported	Not supported

	Field Extension Mode	High-speed Traveling Mode
LOCK	Not supported	Not supported

The commands that can be acknowledged by a Slave Reader/Writer are shown in the following table. If an unsupported command is received by a Slave Reader/Writer, a multi-Reader/Writer execution error will occur.

	Name	Supported
RF Tag communications	READ DATA	No
	WRITE DATA	No
	READ ID	No
	COPY DATA	No
	DATA FILL	No
	LOCK	No
	RF TAG OVERWRITE COUNT CONTROL	No
	RESTORE DATA	No
Reader/Writer settings	SET TAG COMMUNICATIONS OPTION	No
	GET TAG COMMUNICATIONS OPTION	Yes
	SET TAG COMMUNICATIONS CONDITIONS	No
	GET TAG COMMUNICATIONS CONDITIONS	Yes
	SET TCP/IP COMMUNICATIONS CONDITIONS	No
	GET TCP/IP COMMUNICATIONS CONDITIONS	Yes
	SET DEVICE NAME	No
	GET DEVICE NAME	Yes
	SET WEB COMMUNICATIONS CONDITIONS	No
	GET WEB COMMUNICATIONS CONDITIONS	Yes
	SET WEB PASSWORD	No
	GET WEB PASSWORD	Yes
	INITIALIZE	No

	Name	Supported
Checking Reader/Writer information	MEASURE NOISE	No
	GET MODEL INFORMATION	Yes
	GET FIRMWARE VERSION	Yes
	GET MAC ADDRESS	Yes
	GET READER/WRITE OPERATING STATUS	Yes
	GET OPERATING TIME	Yes
	GET RECENT ERROR COMMAND INFORMATION	Yes
	GET COMMUNICATIONS ERROR LOG	Yes
	GET SYSTEM ERROR LOG	Yes
	GET RESTORE INFORMATION	Yes
Reader/Writer operation control	STOP	No
	RESET	No
RFID maintenance	SET COMMUNICATIONS DIAGNOSIS	No
	GET COMMUNICATIONS DIAGNOSIS SETTING	Yes
Multi-Reader/Writer operation	SET MULTI-READER/WRITE OPERATOR	No
	GET MULTI-READER/WRITE SETTINGS	Yes
	GET MULTI-READER/WRITE OPERATOR STATUS	Yes

Field Extension Mode

You can use this mode to link Reader/Writers in order to extend the effective communications field. Even if the workpieces are not all the same height or not oriented in the same direction, the placement of more than one Reader/Writer enables communicating with the RF Tags without worrying about the positions or orientation of the RF Tags.

This enables communications over a wide communications field and is therefore recommended for applications in which the locations or orientation of the RF Tags is not consistent.

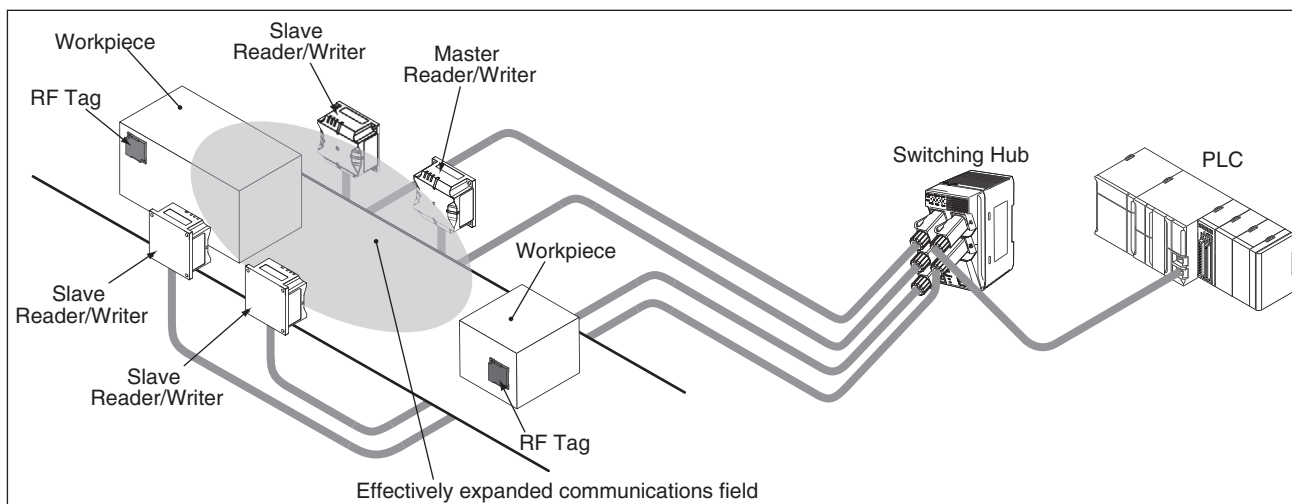

Communicating with RF Tags is possible without being affected by the orientation of the workpieces (i.e., the locations where the RF Tags are attached).

If you use Field Extension Mode, you can use only three RF Tag communications commands: READ DATA, WRITE DATA, and READ ID. Also, you can specify only the Once, Auto or Repeat communications option. If you use the FIFO Repeat communications option in Field Extension Mode, an execution status error will be indicated in the response.

Applicable RF Tag Communications Commands

	Supported
READ DATA	Yes
WRITE DATA	Yes
DATA FILL	No
RF TAG OVERWRITE COUNT CONTROL	No
READ ID	Yes
COPY	No
LOCK	No

Applicable Communications Options

	Supported
Once	Yes
Auto	Yes
Repeat	Yes
FIFO Repeat	No



In Field Extension Mode, the Reader/Writers do not simultaneously perform communications. The Reader/Writers individually perform communications on a time sharing basis.

High-speed Traveling Mode

You can read large data sizes from RF Tags because the data is split up and read by more than one Reader/Writer on a time-sharing basis while the workpiece is moving.

We recommend that you use this mode when reading data from RF Tags that are moving on a production line.

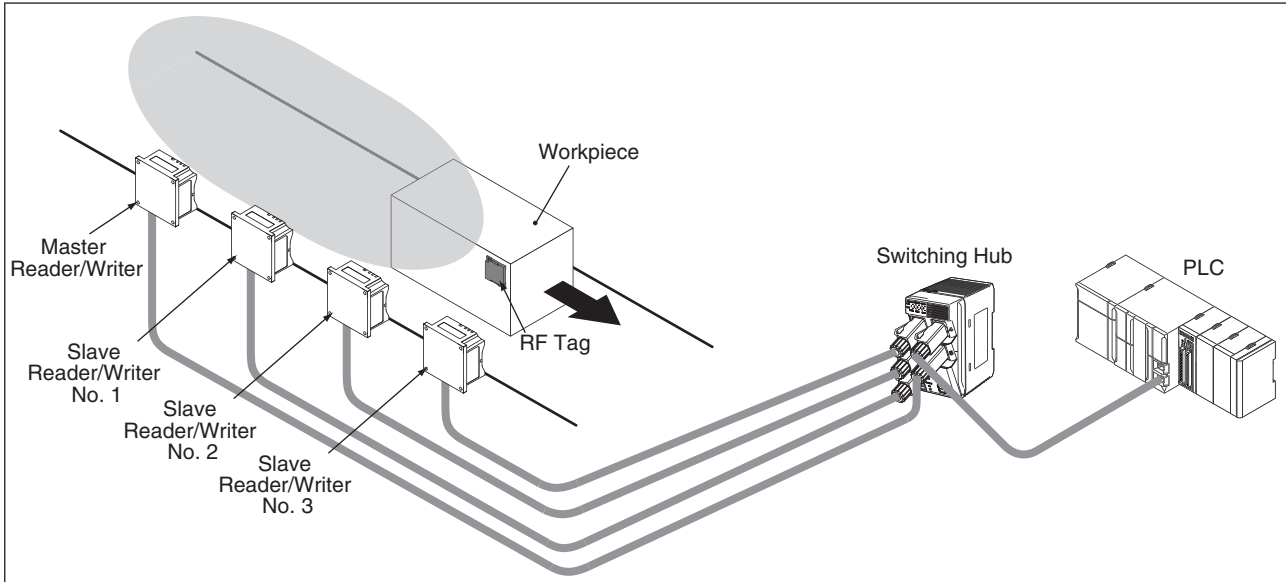

For example, if you link four Reader/Writers and each Reader/Writer can read only 25 words, you can read 100 words of data with the four linked Reader/Writers.

To use the High-speed Traveling Mode, the Master Reader/Writer and Slave Reader/Writers must be set according to their positions.

Read processing is executed in the following order.

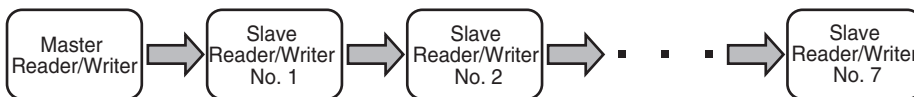

CHECK!

Always set the first Reader/Writer to read data as the Master Reader/Writer. Then set the other Reader/Writers to read data in order from Slave No. 1, Slave No.2, etc.



CHECK!

Refer to *RF Tag Communications Range (for Reference Only)* in *Section 11 Appendices* and install the Reader/Writers so that the communications fields do not overlap. If the Reader/Writers are installed too close to each other, the reading speed will decrease.



p.242



CHECK!

Refer to *Travel Speed Calculations* in *Section 11 Appendices* and set the workpiece travel speed.



p.253

For details, refer to *Using High-speed Traveling Mode* in this section.



p.135



CHECK!

In High-speed Traveling Mode, the Master Reader/Writer must be located first.

In High-speed Traveling Mode, you can use only the READ DATA RF Tag communications command. Also, you can specify only the Auto or Repeat communications option. If you use any communications option other than Repeat in the High-speed Traveling Mode, an execution status error will be indicated in the response.

Applicable RF Tag Communications Commands

	Supported
READ DATA	Yes
WRITE DATA	No
DATA FILL	No
RF TAG OVERWRITE COUNT CONTROL	No
READ ID	No
COPY	No
LOCK	No

Applicable Communications Options

	Supported
Once	No
Auto	Yes
Repeat	Yes
FIFO Repeat	No



CHECK!

In High-speed Traveling Mode, the Reader/Writers do not simultaneously perform communications. The Reader/Writers individually perform communications on a time sharing basis.

Using Communication Diagnostic and the RF Analyzer

You can use communications diagnostics from a Web server. Use either of the following procedures. Use the Web server to use the RF Analyzer.

Using the Web Server

Enabling Communication Diagnostic

1. Connect the Ethernet cable, turn ON the power supply to the Reader/Writer, and then start a Web browser on a computer.

2. Specify the IP address of the Reader/Writer in the address field of the web browser. Enter **http://192.168.1.200/** if you are using the default IP address.

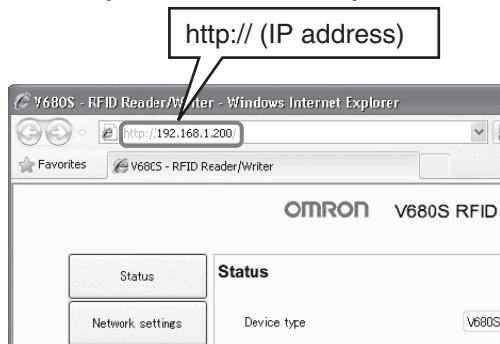

3. The Communications Setting View will be displayed.

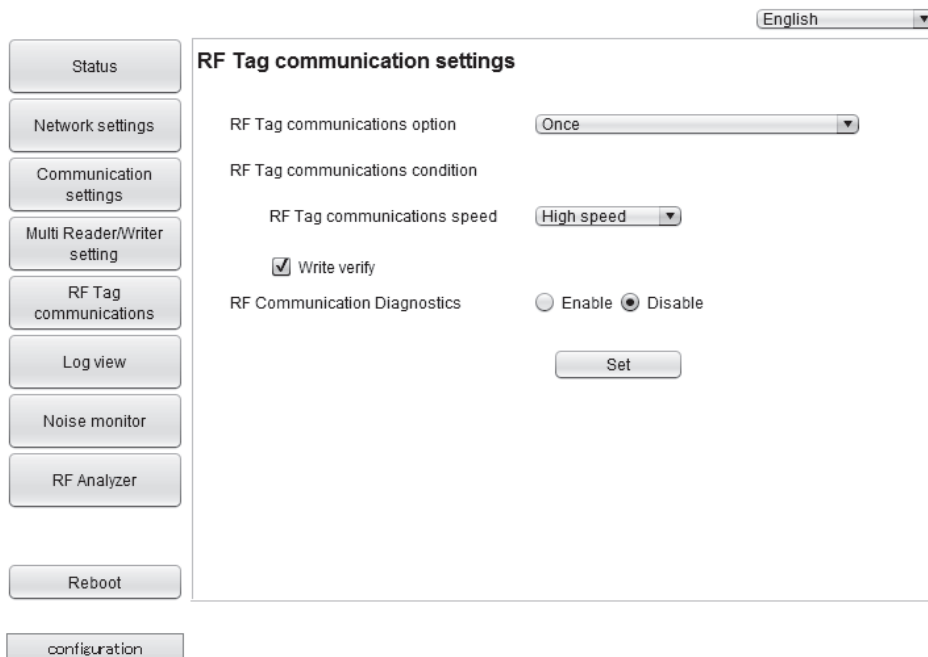

4. Select the *Enable* Option for *Communication Diagnostics* and click the **Set** Button.

Refer to *Communications Settings View* in *Section 8 Browser Interface* for the setting procedure for the web browser interface.

 p.193



When you enable communication diagnostic, the setting will be retained after the Reader/Writer is restarted and communication diagnostic will remain enabled.



You cannot use the communications diagnostics if you are using the FIFO Repeat communications option. Use the Once, Auto or Repeat communications option.

■ Communicating with an RF Tag

1. The RF Tag Communications View will be displayed.

2. Place a RF Tag in front of the Reader/Writer.

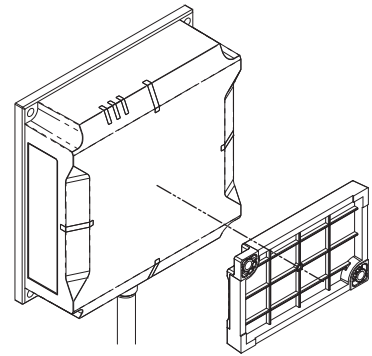

To increase the accuracy of communication diagnostic, we recommend installation in an environment that is as close as possible to the actual application environment.

3. Set the communications parameters (data address, data size, etc.), click the **Send** Button, and check the diagnostic results.

English ▾

Status

Network settings

Communication settings

Multi Reader/Writer setting

RF Tag communications

Log view

Noise monitor

RF Analyzer

Reboot

RF Tag communications

Command Reading RF Tag Writing RF Tag

Read data address

Read data size

Write data address

Data to write

Repeat

Error code/Diagnostic Results The Signal Level is low.

Read data	Number of communications	Clear
00000000	1	

configuration

■ Checking with the RF Analyzer and Implementing Corrections

1. Display the RF Analyzer View.

The screenshot shows the 'RF Analyzer' window with a sidebar on the left containing buttons for Status, Network settings, Communication settings, Multi Reader/Writer setting, RF Tag communications, Log view, Noise monitor, and RF Analyzer. The main window displays a table of diagnostic results:

No	Time	Command	Result	Diagnostic description	Details
1	0:19:29	Read Data	Stable		
2	0:19:36	Read Data	Warning	The Signal Level is low. Push the "Display" button on the right, and follow the instruction.	Display
3	0:19:41	Read Data	Warning	The Signal Level is low. Push the "Display" button on the right, and follow the instruction.	Display
4	0:19:47	Read Data	Error	RF Tag missing error. Check the RF tag are located in front of the Reader/Writer.	
5	0:19:50	Read Data	Error	RF Tag missing error. Check the RF tag are located in front of the Reader/Writer.	
6	0:19:53	Read Data	Error	RF Tag missing error. Check the RF tag are located in front of the Reader/Writer.	

Summary statistics: Total : 14, Warning : 3, Error : 3. Buttons for 'Export', 'Graph', and 'Clear the Log' are visible at the bottom of the table area. A 'configuration' button is located below the table.



You cannot use the RF Tag Analyzer if you are using the FIFO Repeat communications option. Use the Once, Auto or Repeat communications option.

2. Click the **Show** Button in the *Details* column and follow the guidance to check the probable causes and corrections.

OMRON V680S RFID Reader/Writer

The Signal Level is low.

Follow the instruction in below.

There is a possibility the positioning and posture of the Reader/Writer and the RF tag is not proper.

Make a position so that the Reader/Writer and the RF tag surface in face to face, then execute the RF communication diagnostics.

The inclination of the RF tag surface to the Reader/Writer may cause the deterioration of RF communication .

© Copyright OMRON Corporation 2013. All Rights Reserved.

3. In this example, the position of the Tag is corrected according to the guidance.

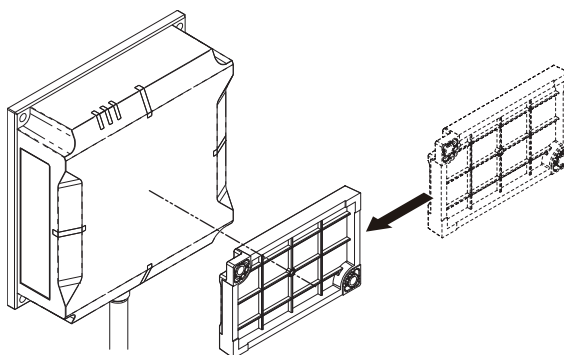

4. You can check the graph display to check quantitative information on the degree of instability.

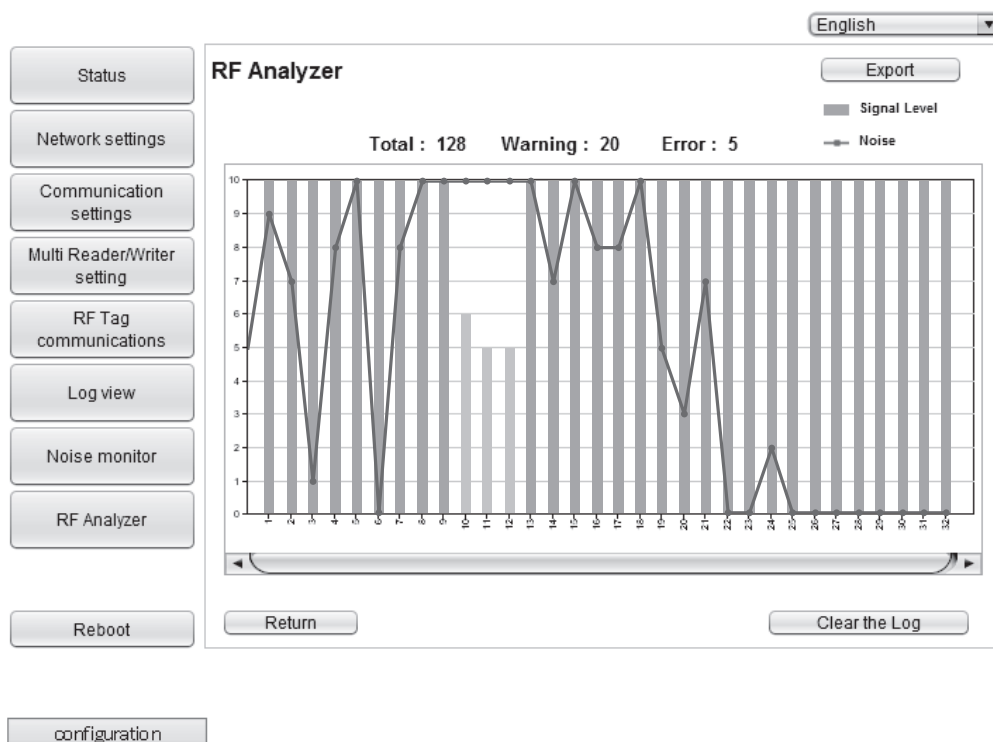

When you are finished, perform the step to communicate with the RF Tag again and check to see if stable communications have been achieved.

Using Multi-Reader/Writer Operation

Using Field Extension Mode

Use the following procedure for operation in Field Extension Mode. The following figure shows an example in which four Reader/Writers are installed.

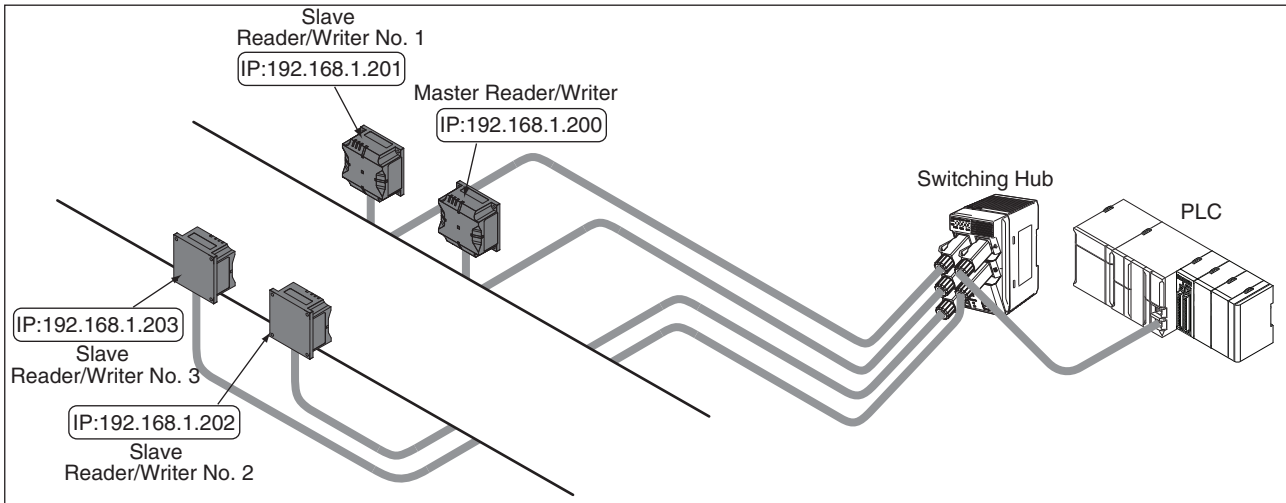

■ Enabling Field Extension Mode

1. Connect all of the Reader/Writers with Ethernet Cables and turn ON the power supplies.



Set a unique IP address for each Reader/Writer in advance.
Refer to *Section 5 Preparations for Communications*.

CHECK!

2. Start a Web browser on your computer.
3. In the address field on the Web browser operation window, enter the IP address of the master Reader/Writer (here, 192.168.1.200).

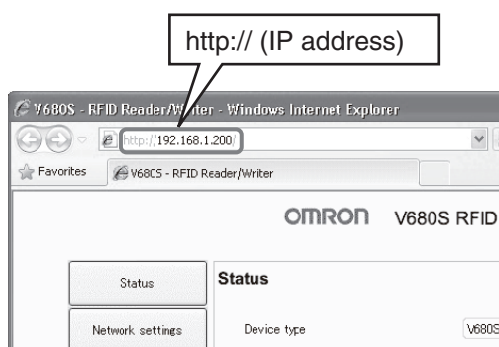

4. Display the RF Tag Communications Settings View, set the RF Tag communications option to Once, Auto or Repeat, and then click the **Set** Button.

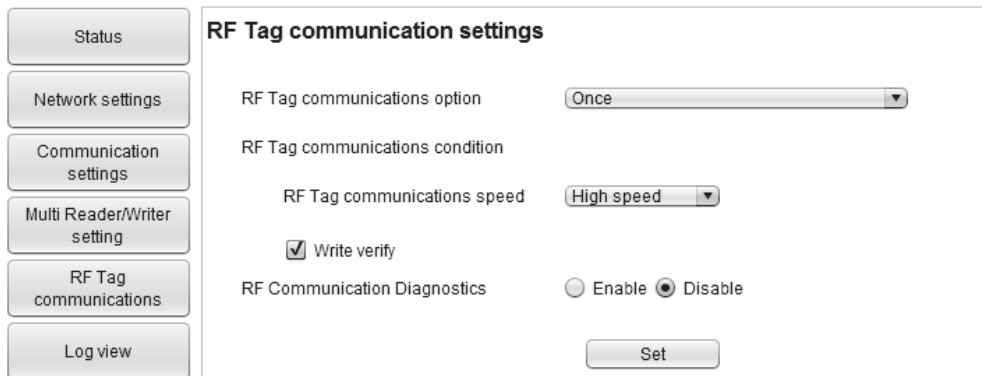

If you specify the FIFO Repeat communications option, multi-Reader/Writer operation will be enabled and a multi-Reader/Writer execution error will occur when you restart.

CHECK!

5. Display the Multi-Reader/Writer Settings View.

English

Status	Multi Reader/Writer setting		
Network settings	Multi Reader/Writer mode <input checked="" type="radio"/> Disable <input type="radio"/> Field extension mode <input type="radio"/> High-speed travelling mode		
Communication settings	Group setting	IP address	Status
Multi Reader/Writer setting	Slave Reader/Writer No.1	<input type="text"/>	<input type="checkbox"/>
RF Tag communications	Slave Reader/Writer No.2	<input type="text"/>	<input type="checkbox"/>
Log view	Slave Reader/Writer No.3	<input type="text"/>	<input type="checkbox"/>
Noise monitor	Slave Reader/Writer No.4	<input type="text"/>	<input type="checkbox"/>
RF Analyzer	Slave Reader/Writer No.5	<input type="text"/>	<input type="checkbox"/>
Reboot	Slave Reader/Writer No.6	<input type="text"/>	<input type="checkbox"/>
	Slave Reader/Writer No.7	<input type="text"/>	<input type="checkbox"/>
			<input type="button" value="Set"/>

6. Select the *Field Extension Mode* Check Box.

English

Status	Multi Reader/Writer setting		
Network settings	Multi Reader/Writer mode <input type="radio"/> Disable <input checked="" type="radio"/> Field extension mode <input type="radio"/> High-speed travelling mode		

7. Set the IP addresses of the three slave Reader/Writers and click the **Set** Button.

Communication settings	Group setting	IP address	Status
Multi Reader/Writer setting	Slave Reader/Writer No.1	<input type="text" value="192.168.1.201"/>	<input type="checkbox"/>
RF Tag communications	Slave Reader/Writer No.2	<input type="text" value="192.168.1.202"/>	<input type="checkbox"/>
Log view	Slave Reader/Writer No.3	<input type="text" value="192.168.1.203"/>	<input type="checkbox"/>
Noise monitor	Slave Reader/Writer No.4	<input type="text"/>	<input type="checkbox"/>
RF Analyzer	Slave Reader/Writer No.5	<input type="text"/>	<input type="checkbox"/>
	Slave Reader/Writer No.6	<input type="text"/>	<input type="checkbox"/>
	Slave Reader/Writer No.7	<input type="text"/>	<input type="checkbox"/>

8. A confirmation message will be displayed. Click the **OK** Button.

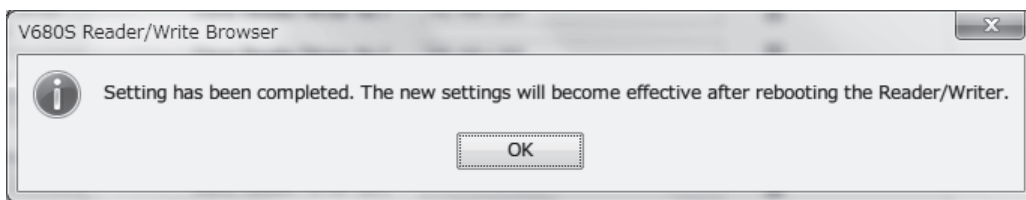
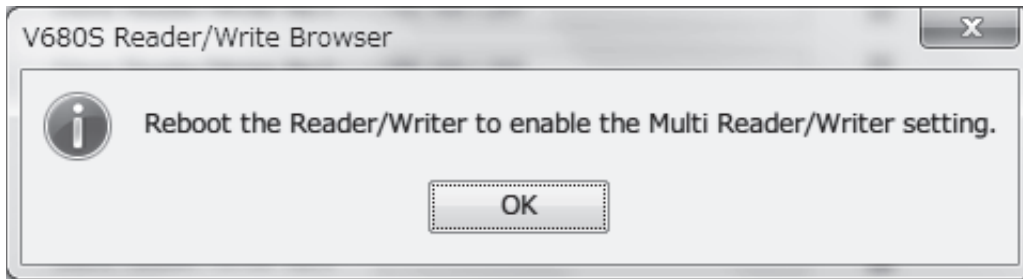

9. Click the **Reboot** Button. A Confirm Reboot Dialog Box will be displayed. Click the **Yes** Button.

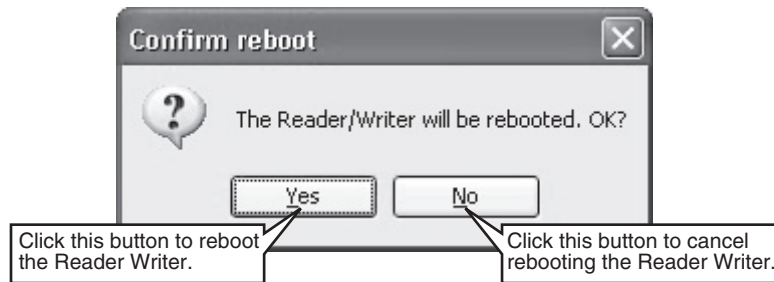

10. The following dialog box is displayed after the Reader/Writer has finished rebooting. Click the **Yes** Button to connect to the Reader/Writer.

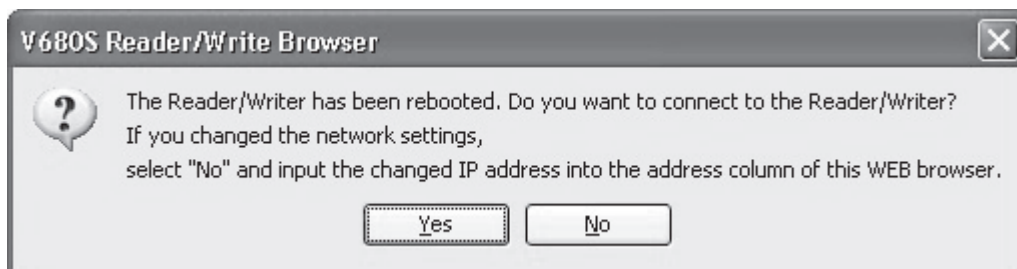

11. The following dialog box is displayed after reconnecting to the Reader/Writer. Click the **OK** Button.



When re-connection goes wrong and an error message is displayed, check connection with the Reader/Writer and reboot a browser.

12. When the Master Reader/Writer is restarted, group registration processing is automatically performed for the registered Slave Reader/Writers.



If the Master Reader/Writer cannot establish communications with a registered Slave Reader/Writer (e.g., due to an incorrect IP address or because the Slave Reader/Writer is not started), the ERROR indicator (red) on the Master Reader/Writer will flash at 1-s intervals.

13. You can confirm when communications have been established with all of the slave Reader/Writer from the Multi-Reader/Writer Setting View of the Web browser operation window.

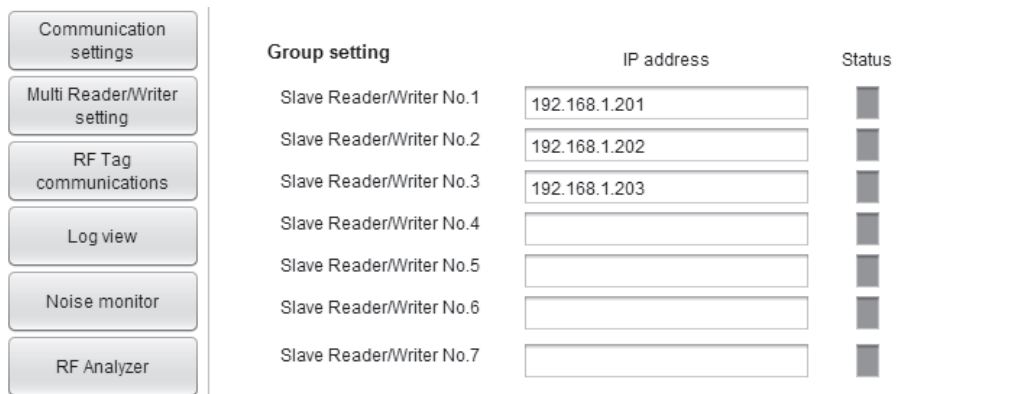

14. The RUN indicator will light yellow on Reader/Writers that are operating as slave Reader/Writers. The indicator on the master Reader/Writer will remain lit green.

15. This concludes the procedure to set Field Extension Mode. You can now use READ DATA or WRITE DATA commands from the host controller for the Master Reader/Writer to perform linked operation of multiple Reader/Writers.

■ Executing a READ DATA Command in Field Extension Mode.

- When the RF Tag Communications Option of the Master Reader/Writer Is Set to Once

1. Send a READ DATA command from the host device to the Master Reader/Writer.

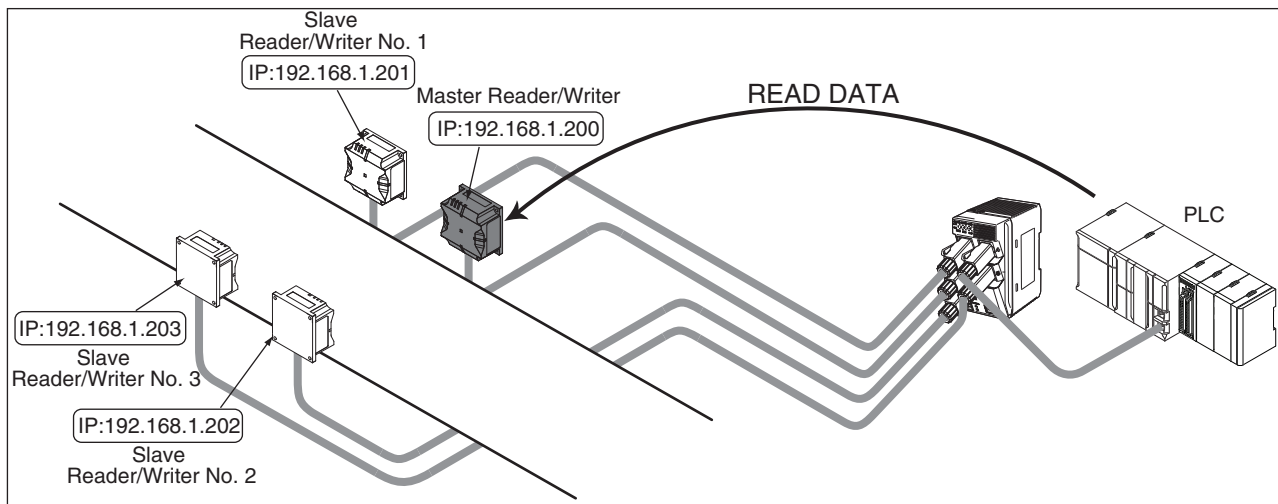

2. The Master Reader/Writer will communicate with the RF Tag using the Once communications option. Here, communications will end normally or an RF Tag communications error will occur, the Reader/Writer will return a response to the host device, and processing will end. If an RF Tag missing error is detected, processing proceeds to step 3.

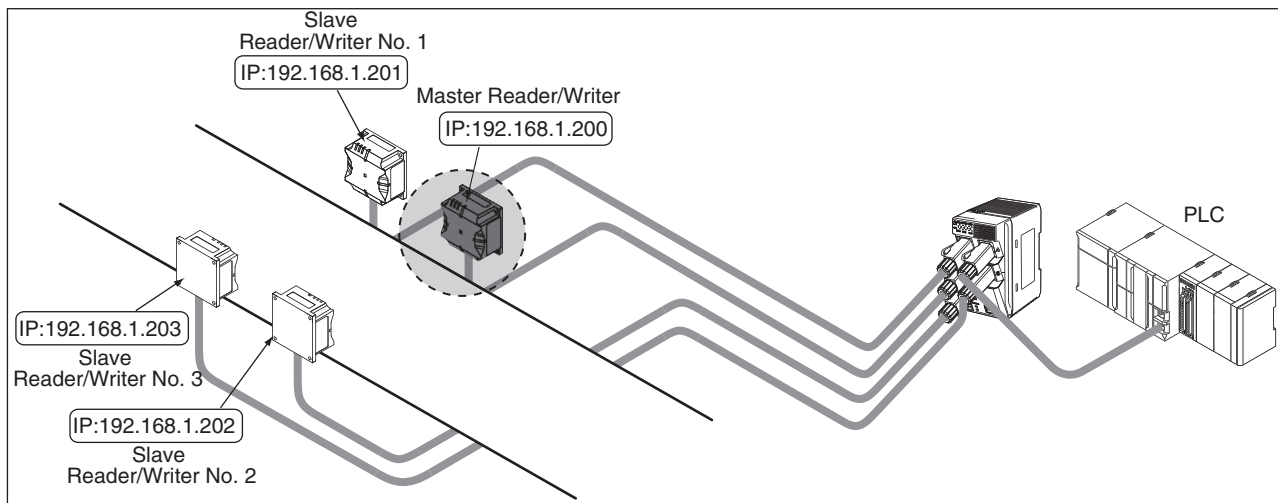

- Slave Reader/Writer No. 1 will communicate with the RF Tag using the Once communications option. Here, communications will end normally or an RF Tag communications error will occur, the Reader/Writer will return a response to the host device, and processing will end. If an RF Tag tag missing error is detected, processing will be continued in order by Slave No. 2 and then by Slave No. 3.

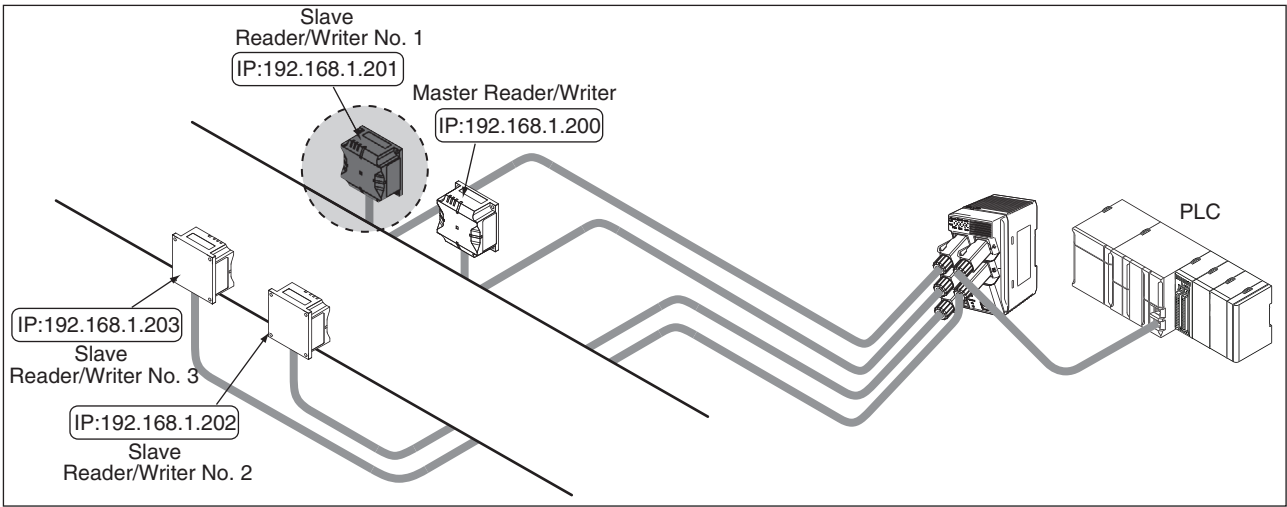

- If an RF Tag missing error is detected for Slave No. 3, the error is returned to the host device and processing ends.

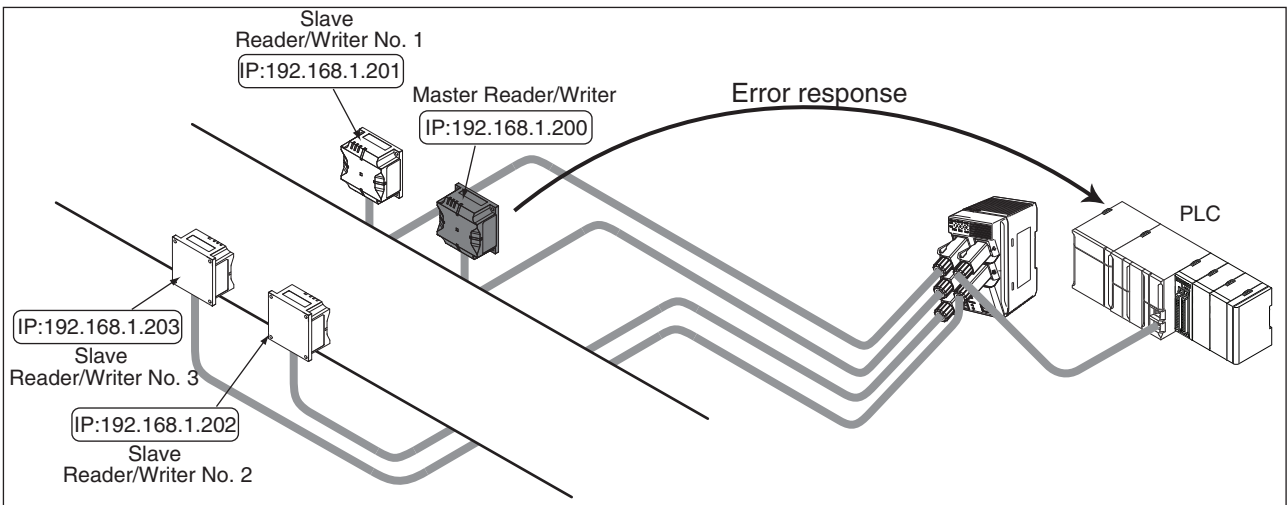

▪ **When the RF Tag Communications Option of the Master Reader/Writer Is Set to Auto**

1. Send a READ DATA command from the host device to the Master Reader/Writer.

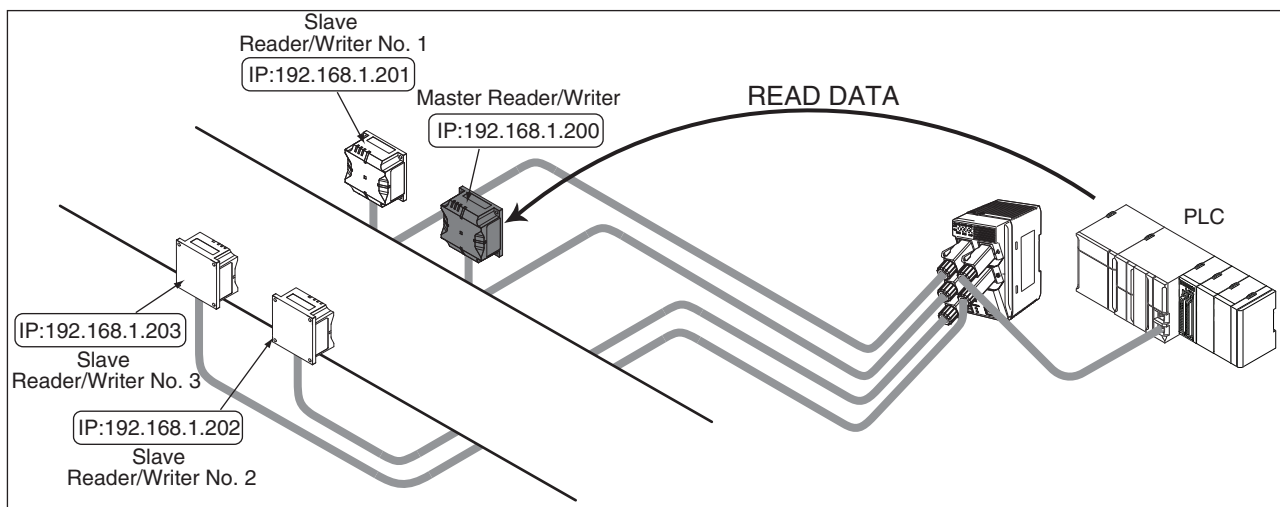

2. The Master Reader/Writer will communicate with the RF Tag using the Once communications option. Here, communications will end normally or an RF Tag communications error will occur, the Reader/Writer will return a response to the host device, and processing will end. If an RF Tag missing error is detected, processing proceeds to step 3.

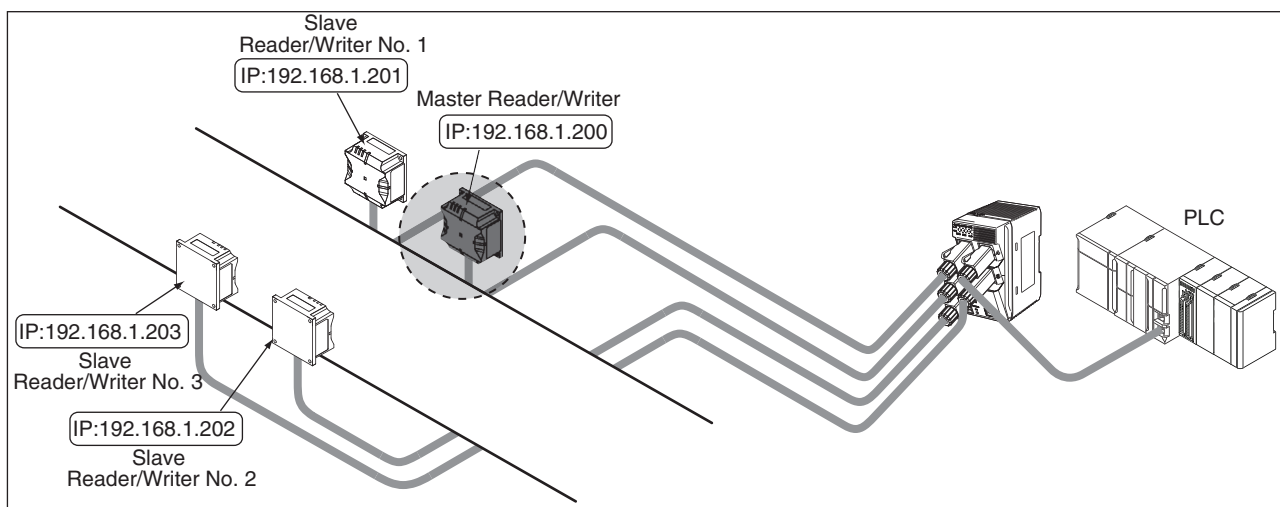

- Slave Reader/Writer No. 1 will communicate with the RF Tag using the Once communications option. Here, communications will end normally or an RF Tag communications error will occur, the Reader/Writer will return a response to the host device, and processing will end. If an RF Tag tag missing error is detected, processing will be continued in order by Slave No. 2 and then by Slave No. 3.

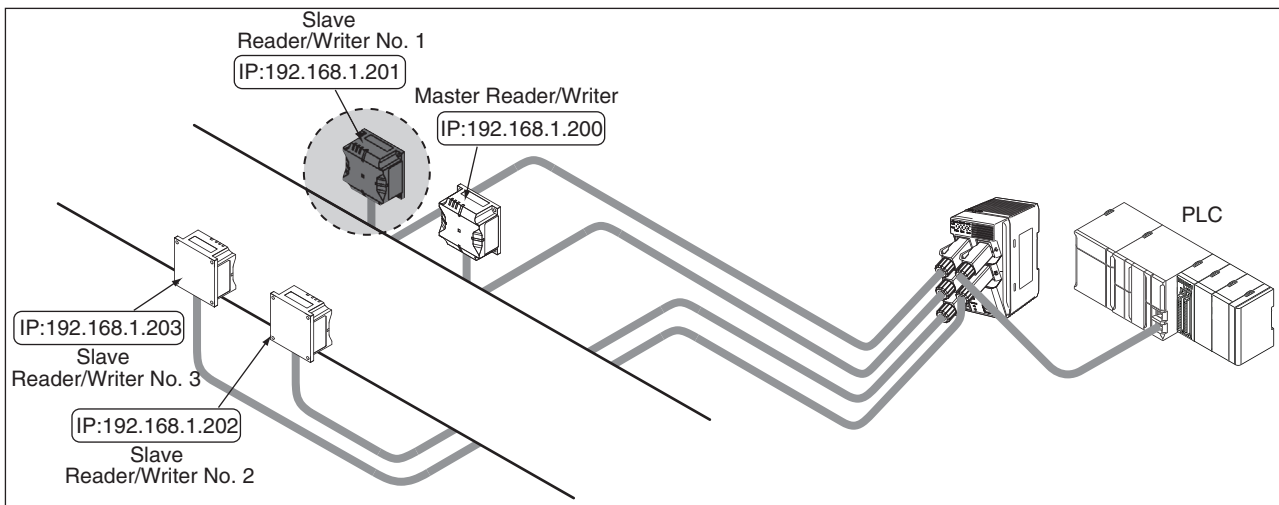

- If an RF Tag missing error is detected for Slave No.3, communications processing is returned to the Master Reader/Writer and the operation is repeated from step 2.

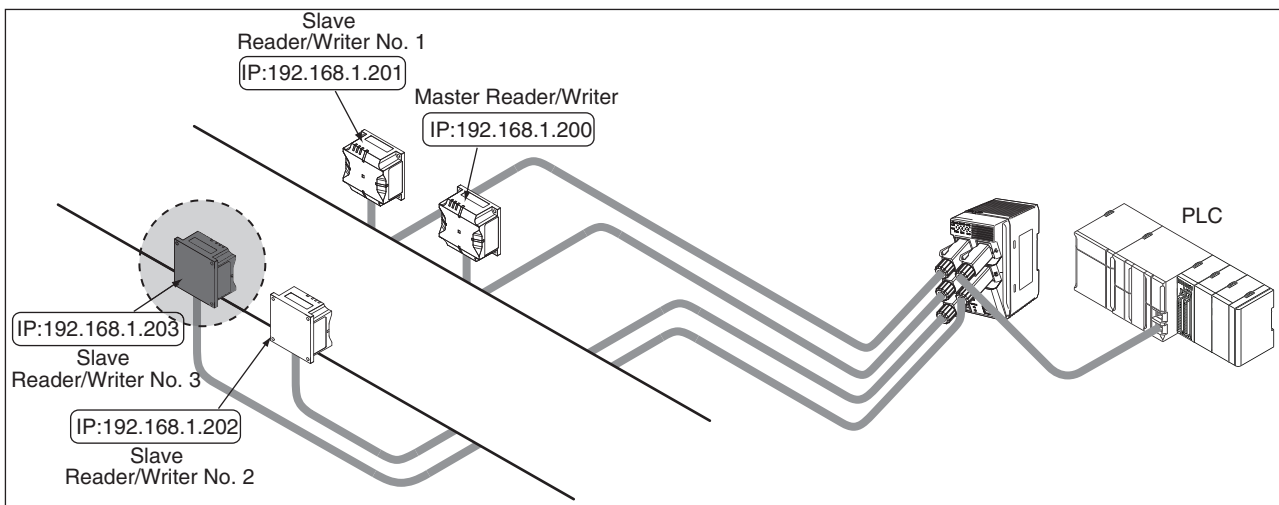

In Field Extension Mode, the Reader/Writers do not simultaneously perform communications. The Reader/Writers individually perform communications on a time sharing basis.

▪ **When the RF Tag Communications Option of the Master Reader/Writer Is Set to Repeat**

1. Send a READ DATA command from the host device to the Master Reader/Writer.

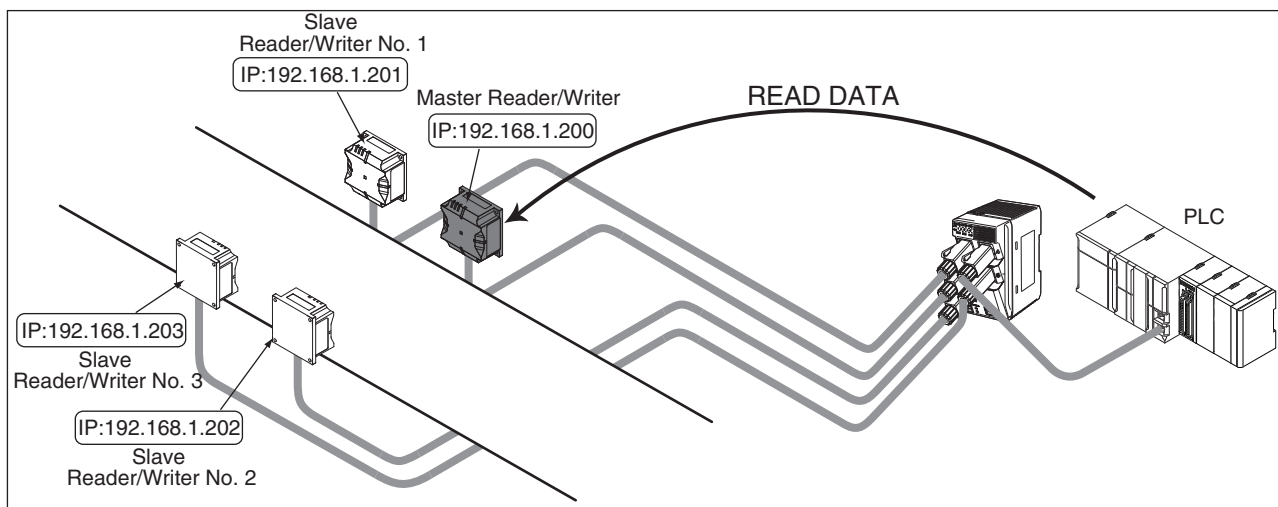

2. The Master Reader/Writer will communicate with the RF Tag using the Once communications option. Here, if RF Tag communications end normally, the Reader/Writer will return a response to the host device and processing is repeated from step 2. If an RF Tag missing error is detected, processing proceeds to step 3.

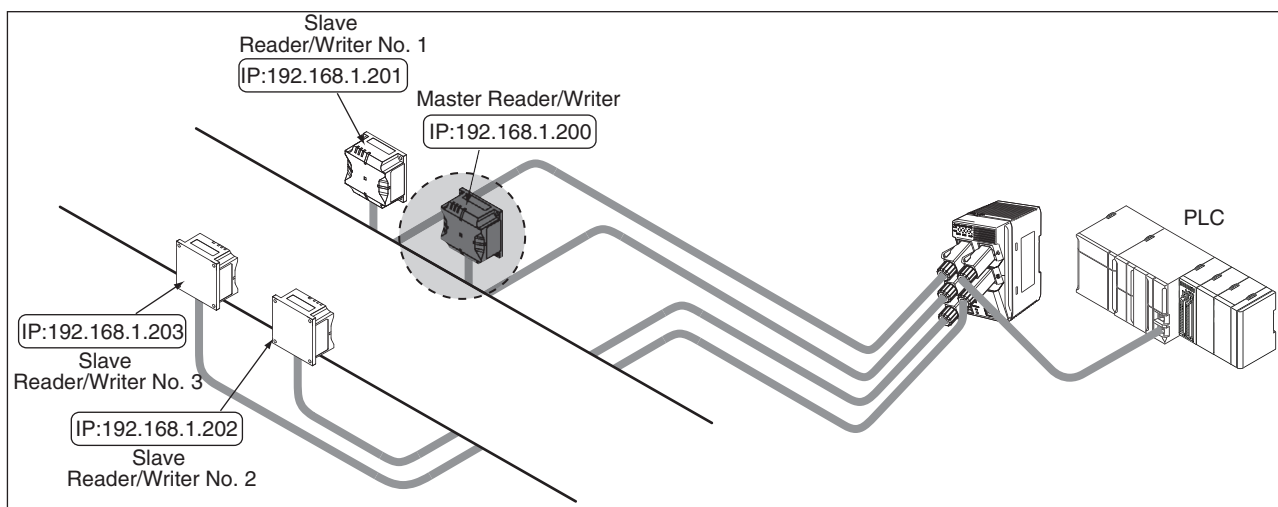

- Slave Reader/Writer No. 1 will communicate with the RF Tag using the Once communications option. Here, if RF Tag communications end normally, the Reader/Writer will return a response to the host device and processing is repeated from step 2. If an RF Tag tag missing error is detected, processing will be continued in order by Slave No. 2 and then by Slave No. 3.

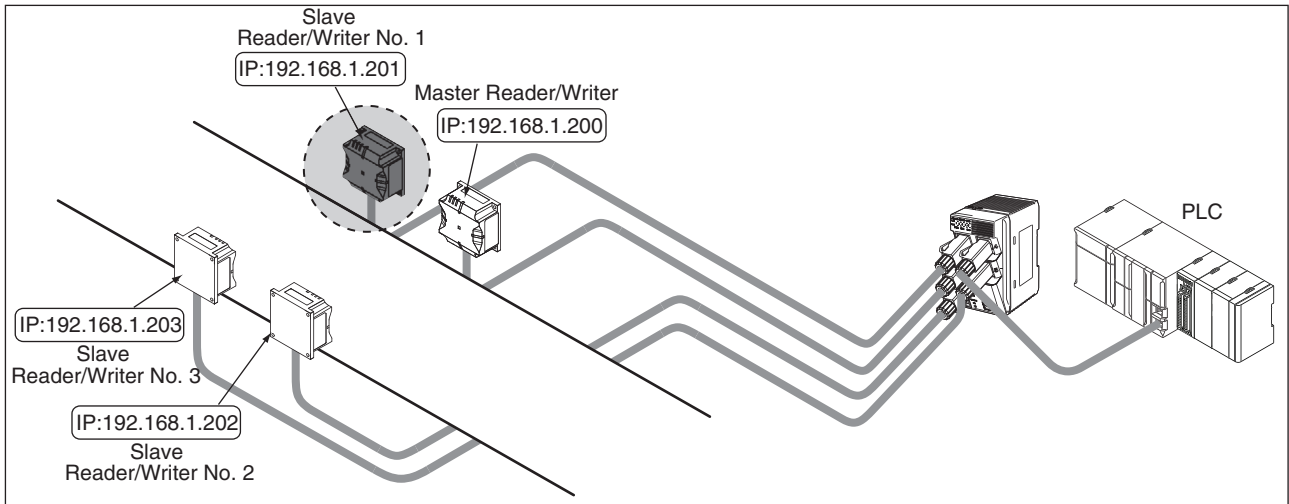

- When communications have been completed for all of the Slave Reader/Writers, the operation is repeated from step 2.

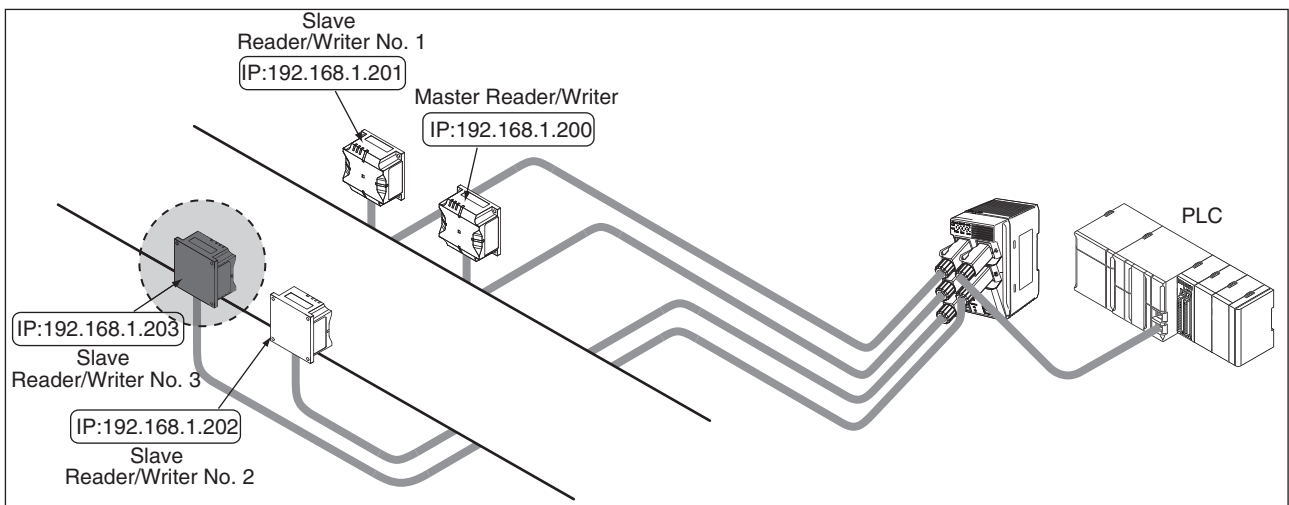

In Field Extension Mode, the Reader/Writers do not simultaneously perform communications. The Reader/Writers individually perform communications on a time sharing basis.

Using High-speed Traveling Mode

Use the following procedure for operation in High-speed Traveling Mode. The following figure shows an example in which four Reader/Writers are installed.

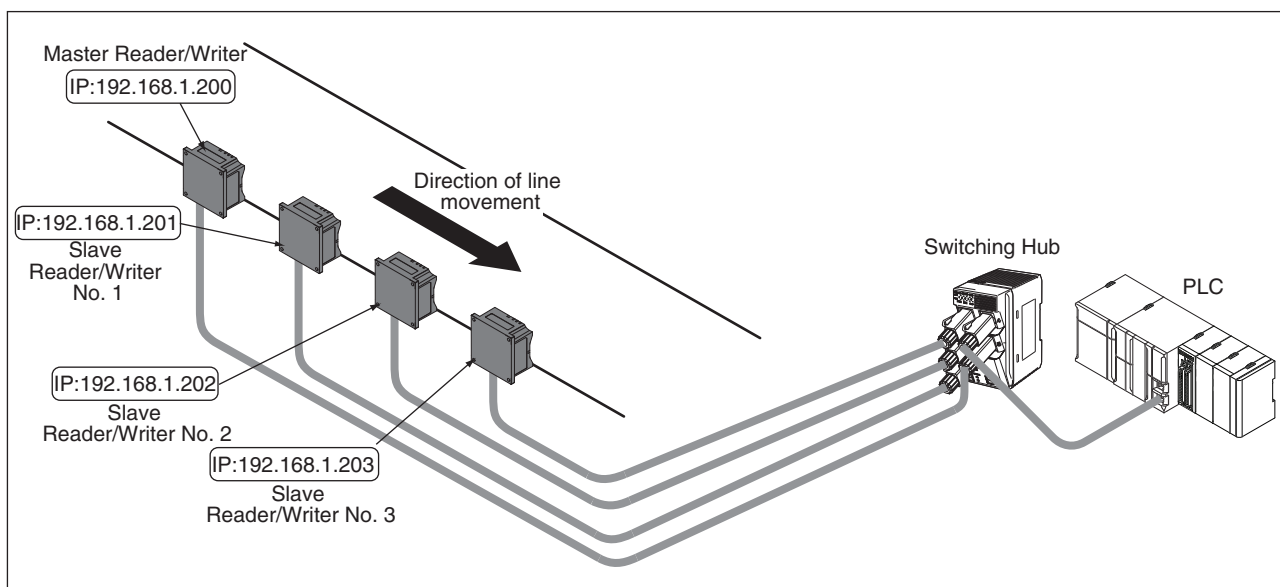

■ Enabling High-speed Traveling Mode

1. Connect all of the Reader/Writers with Ethernet Cable and turn ON the power supplies.



Set a unique IP address for each Reader/Writer in advance.
Refer to *Section 5 Preparations for Communications*.

CHECK!

2. Start a Web browser on your computer.

3. In the address field on the Web browser operation window, enter the IP address of the master Reader/Writer (here, 192.168.1.200).

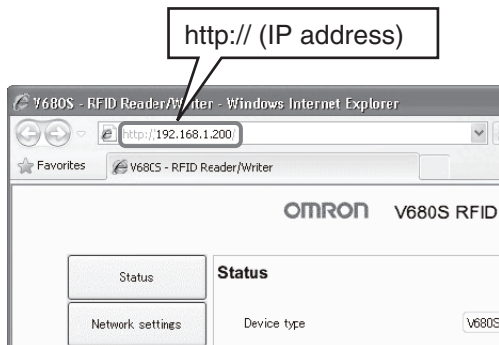

4. Display the RF Tag Communications Settings View, set the RF Tag communications option to Repeat, and then click the **Set** Button.

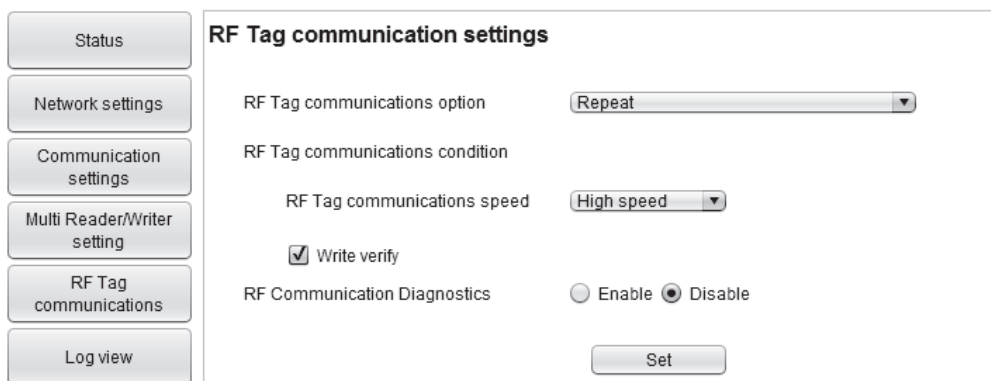

If you specify the Once or FIFO Repeat communications option, multi-Reader/Writer operation will be enabled and a multi-Reader/Writer execution error will occur when you restart.

CHECK!

5. Display the Multi-Reader/Writer Settings View.

English ▾

Status

Network settings

Communication settings

Multi Reader/Writer setting

RF Tag communications

Log view

Noise monitor

RF Analyzer

Reboot

Multi Reader/Writer setting

Multi Reader/Writer mode Disable Field extension mode High-speed travelling mode

Group setting	IP address	Status
Slave Reader/Writer No.1	<input type="text"/>	<input type="checkbox"/>
Slave Reader/Writer No.2	<input type="text"/>	<input type="checkbox"/>
Slave Reader/Writer No.3	<input type="text"/>	<input type="checkbox"/>
Slave Reader/Writer No.4	<input type="text"/>	<input type="checkbox"/>
Slave Reader/Writer No.5	<input type="text"/>	<input type="checkbox"/>
Slave Reader/Writer No.6	<input type="text"/>	<input type="checkbox"/>
Slave Reader/Writer No.7	<input type="text"/>	<input type="checkbox"/>

Set

6. Select the *High-speed travelling mode* Check Box.

English ▾

Status

Network settings

Multi Reader/Writer setting

Multi Reader/Writer mode Disable Field extension mode High-speed travelling mode

7. Set the IP addresses of the three slave Reader/Writers and click the **Set** Button.

Communication settings

Multi Reader/Writer setting

RF Tag communications

Log view

Noise monitor

RF Analyzer

Group setting	IP address	Status
Slave Reader/Writer No.1	<input type="text" value="192.168.1.201"/>	<input type="checkbox"/>
Slave Reader/Writer No.2	<input type="text" value="192.168.1.202"/>	<input type="checkbox"/>
Slave Reader/Writer No.3	<input type="text" value="192.168.1.203"/>	<input type="checkbox"/>
Slave Reader/Writer No.4	<input type="text"/>	<input type="checkbox"/>
Slave Reader/Writer No.5	<input type="text"/>	<input type="checkbox"/>
Slave Reader/Writer No.6	<input type="text"/>	<input type="checkbox"/>
Slave Reader/Writer No.7	<input type="text"/>	<input type="checkbox"/>

8. A confirmation message will be displayed. Click the **OK** Button.

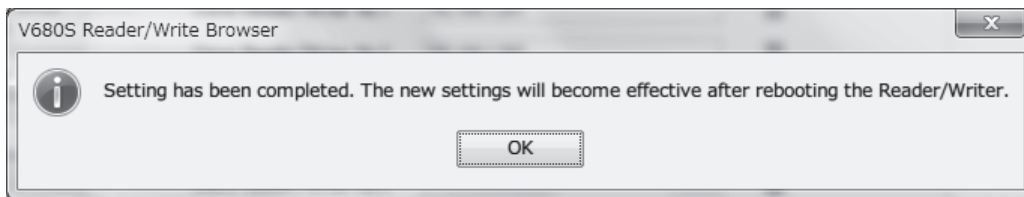
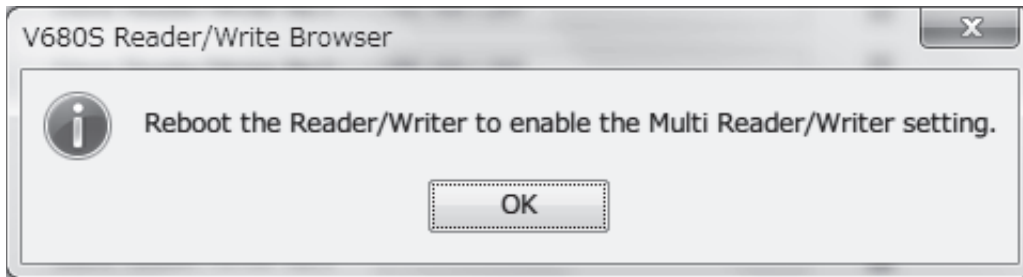

9. Click the **Reboot** Button. A Confirm Reboot Dialog Box will be displayed. Click the **Yes** Button.

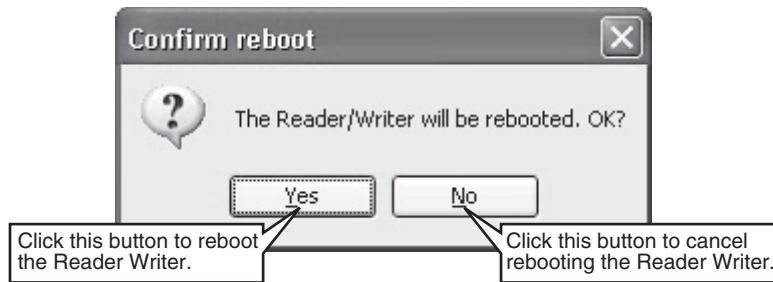

10. The following dialog box is displayed after the Reader/Writer has finished rebooting. Click the **Yes** Button to connect to the Reader/Writer.

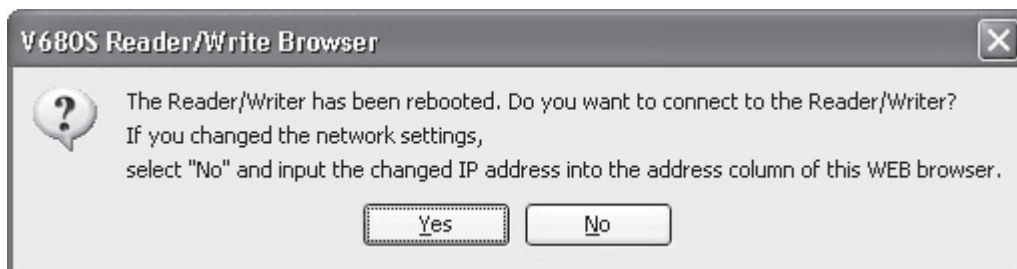

- 11.** The following dialog box is displayed after reconnecting to the Reader/Writer. Click the **OK** Button.



When re-connection goes wrong and an error message is displayed, check connection with the Reader/Writer and reboot a browser.

- 12.** When the Master Reader/Writer is restarted, group registration processing is automatically performed for the registered Slave Reader/Writers.



If the Master Reader/Writer cannot establish communications with a registered Slave Reader/Writer (e.g., due to an incorrect IP address or because the Slave Reader/Writer is not started), the ERROR indicator (red) on the Master Reader/Writer will flash at 1-s intervals.

- 13.** You can confirm when communications have been established with all of the slave Reader/Writer from the Multi-Reader/Writer Setting View of the Web browser operation window.

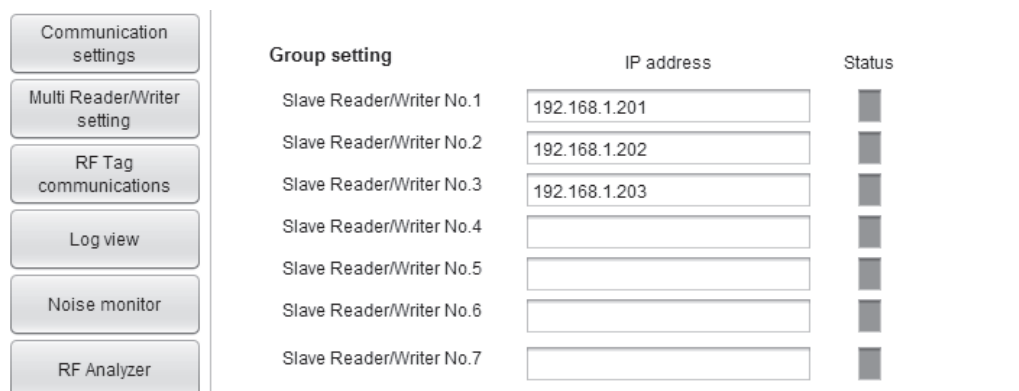

- 14.** The RUN indicator will light yellow on Reader/Writers that are operating as slave Reader/Writers. The indicator on the master Reader/Writer will remain lit green.
- 15.** This concludes the procedure to set Field Extension Mode. You can now use READ DATA or WRITE DATA commands from the host controller for the Master Reader/Writer to perform linked operation of multiple Reader/Writers.

■ Executing a READ DATA Command in High-speed Traveling Mode.

1. Send a READ DATA command from the host device to the Master Reader/Writer.

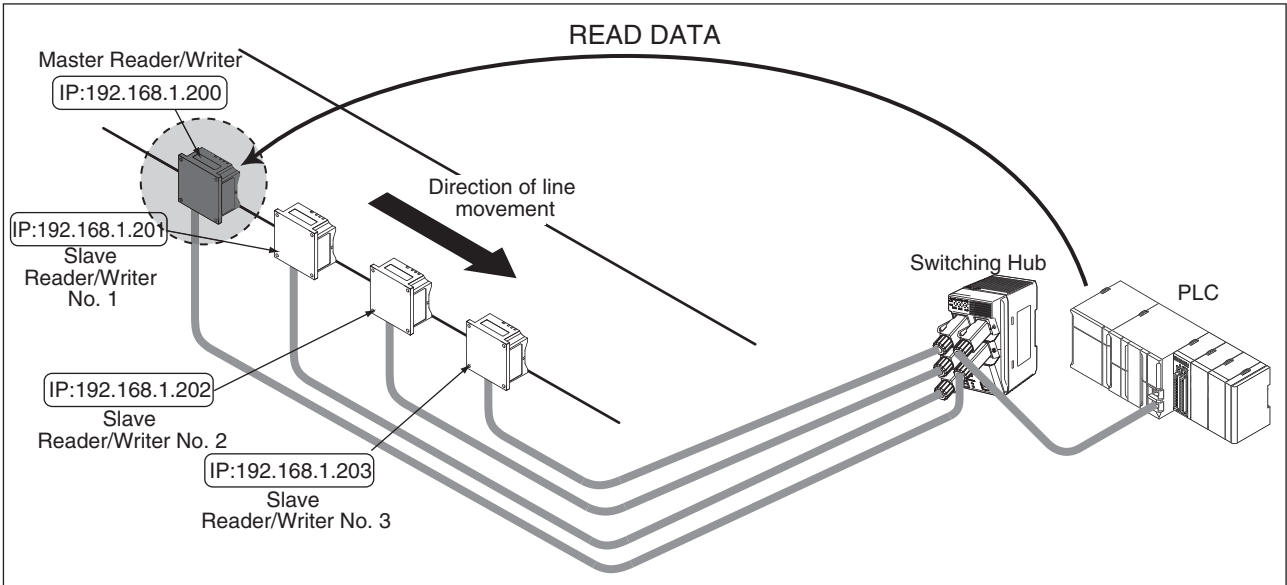

2. The Master Reader/Writer will wait for an RF Tag to enter the communications field and then communicate with the RF Tag.

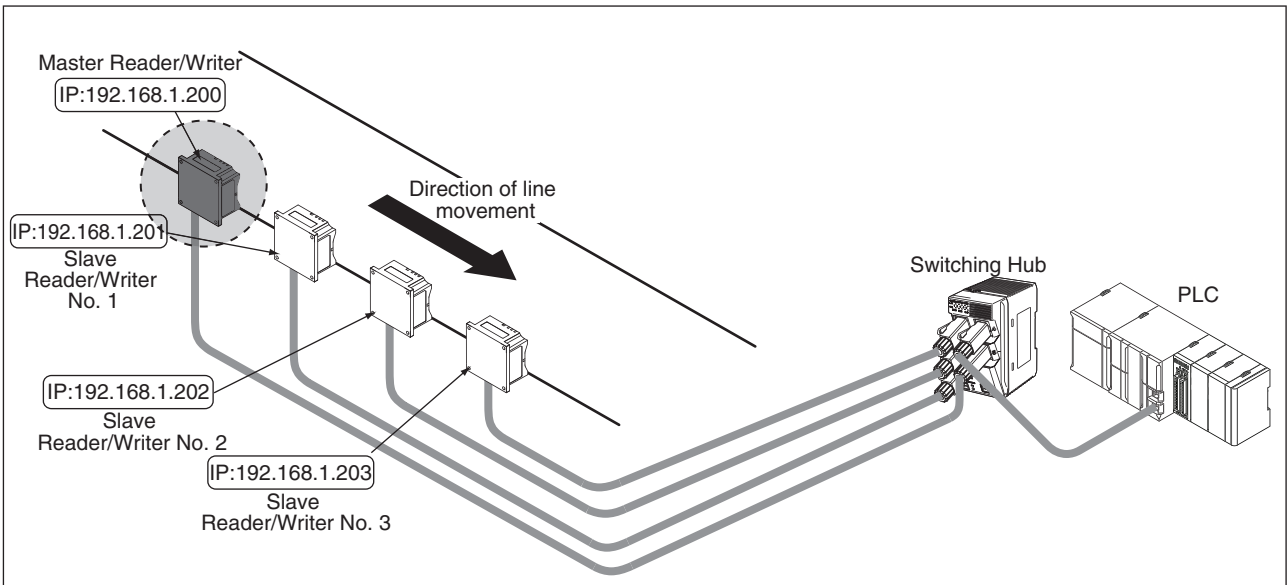

- Slave No. 1 will wait for an RF Tag to enter the communications field and then communicate with the RF Tag. If communicating with the RF Tag ends normally, processing will be continued in order by Slave No. 2 and then by Slave No. 3.

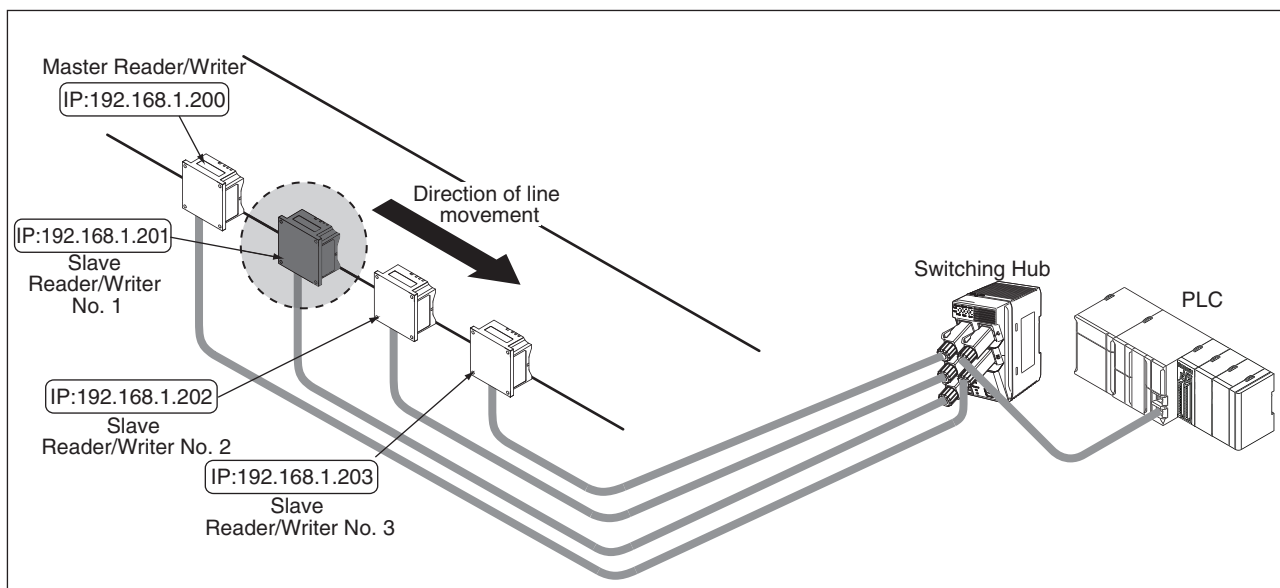

- If all communications with the RF Tag end normally, the read data is returned to the host device and processing returns to step 2.

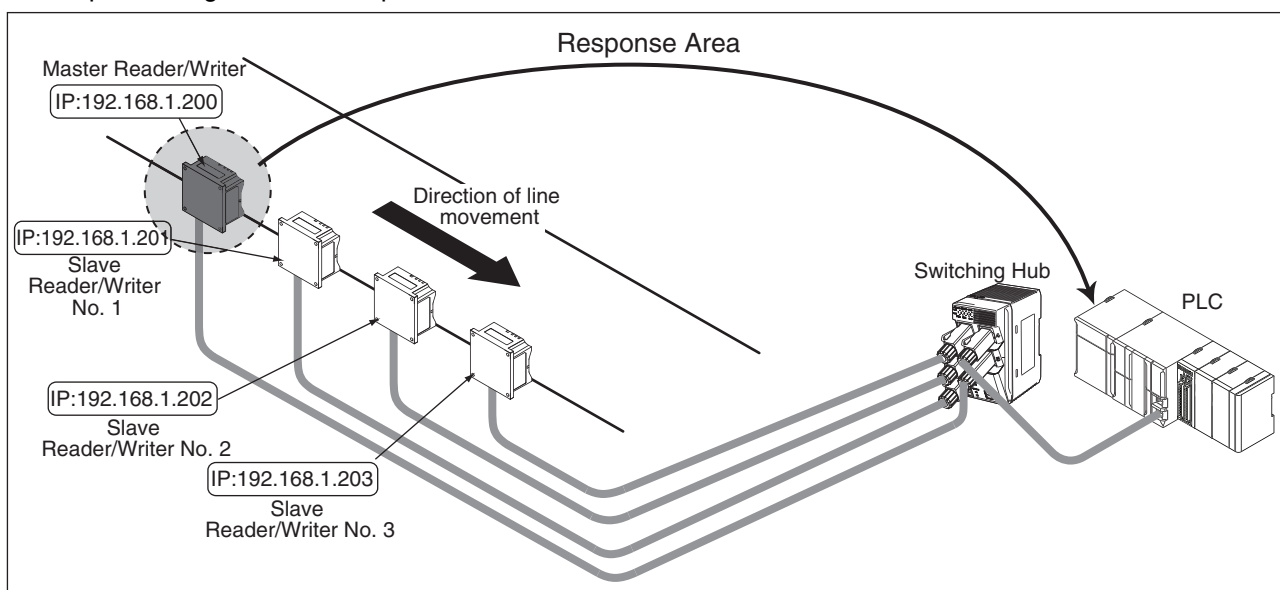

Disabling Multi-Reader/Writer Operation

The following example procedure shows how to disable the multi-Reader/Writer operation. You can use the same procedure from either Field Extension Mode or High-speed Traveling Mode.

1. Start the Web browser on your computer and enter the IP address of the master Reader/Writer (here, 192.168.1.200) in the address field.

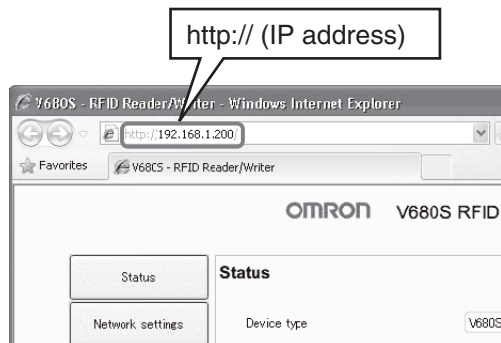

2. Display the Multi-Reader/Writer Settings View.

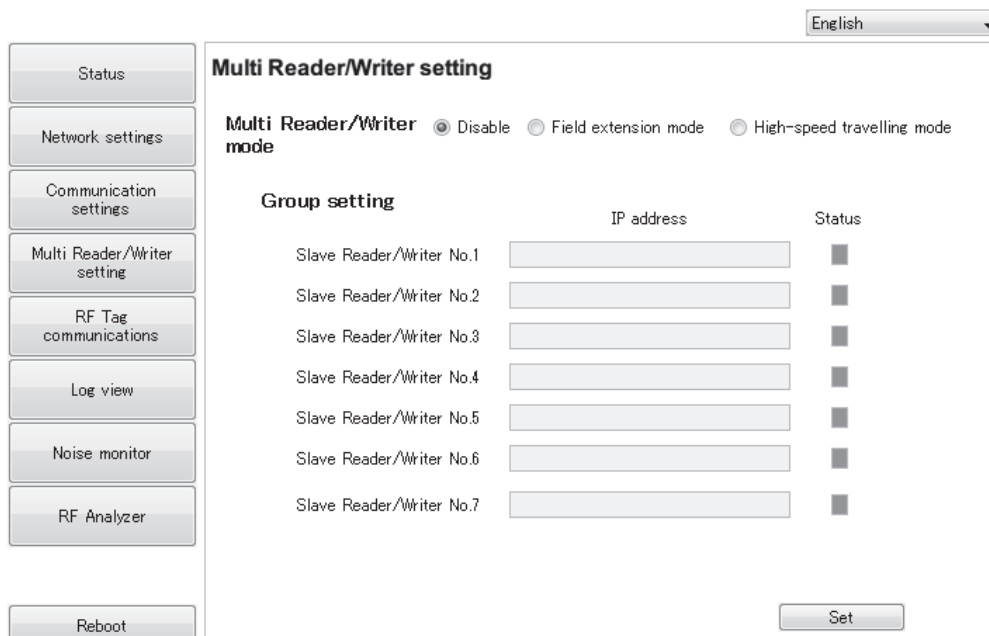

3. Select the *Disable* Check Box for Multi-Reader/Writer Mode and click the **Set** Button.

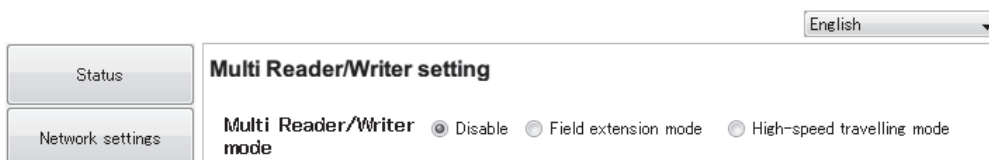

4. A confirmation message will be displayed. Click the **OK** Button.

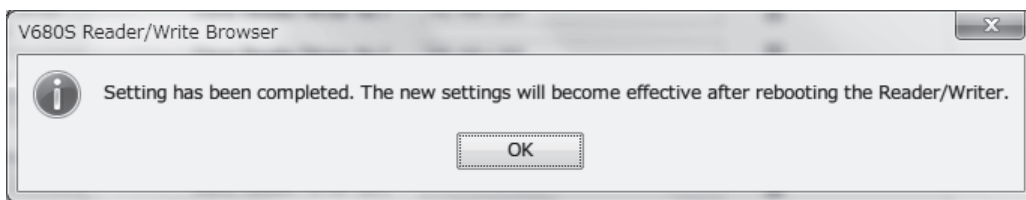
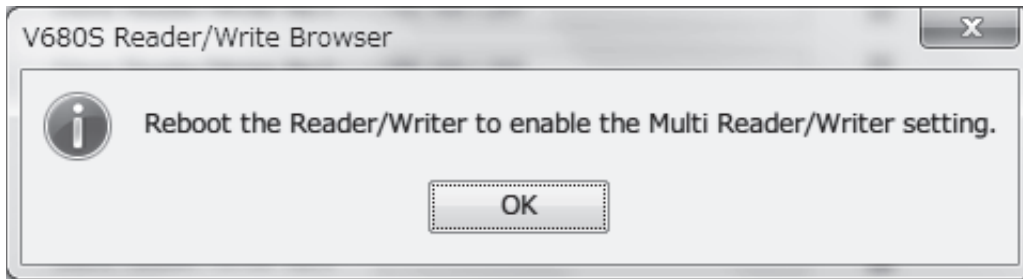

5. Click the **Reboot** Button. A Confirm Reboot Dialog Box will be displayed. Click the **Yes** Button.

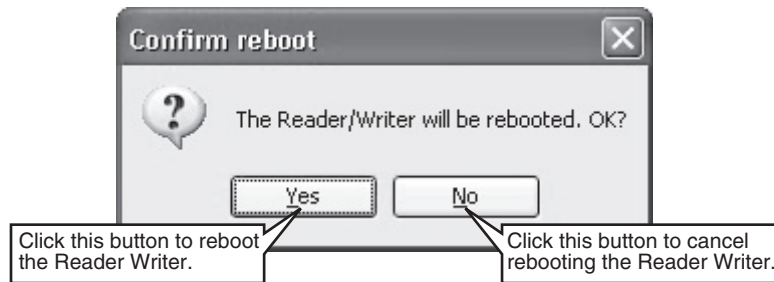

If you turn OFF the power supplies to the Slave Reader/Writers or if a communications error occurs for a Slave Reader/Writer (e.g., Ethernet Cable disconnection) before you restart the Reader/Writers, an execution status error will occur and the Reader/Writers will not restart normally. If that occurs, turn OFF the power supplies to all of the Reader/Writers and then turn them back ON.

6. The following dialog box is displayed after the Reader/Writer has finished rebooting. Click the **Yes** Button to connect to the Reader/Writer.

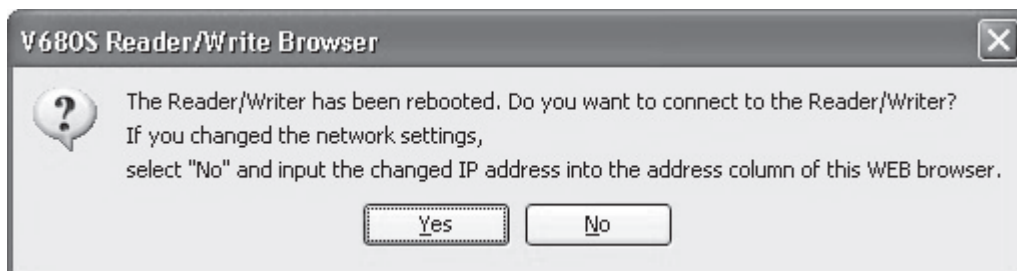

7. The following dialog box is displayed after reconnecting to the Reader/Writer. Click the **OK** Button.



8. The Slave Reader/Writers will also be restarted automatically. This concludes the procedure to disable multi-Reader/Writer operation.



When the Field Extension Mode is disabled, the RUN indicators on the Slave Reader/Writers will fast flashing green.

Section 7

Host Communications Specifications

☒	EtherNet/IP Communications Protocol	146
	Data Exchange with Ethernet/IP	146
	EtherNet/IP Communications with the Reader/Writer	147
	Tag Data Link Setting Methods	148
	Memory Assignments	150
	V680S Commands	152
☒	V680S Command Details	156
	READ ID	156
	READ DATA	157
	WRITE DATA	158
	LOCK	159
	DATA FILL	160
	RF TAG OVERWRITE COUNT CONTROL	161
	RESTORE DATA	162
	COPY DATA	163
	INITIALIZE	165
	SET RF TAG COMMUNICATIONS	166
	GET RF TAG COMMUNICATIONS SETTINGS	167
	SET MULTI-READER/WRITER OPERATION	168
	GET MULTI-READER/WRITER SETTINGS	170
	GET MODEL INFORMATION	172
	GET FIRMWARE VERSION	173
	GET OPERATING TIME	174
	MEASURE NOISE	175
	GET COMMAND ERROR LOG	176
	GET RESTORE INFORMATION	178
	GET MULTI-READER/WRITER STATUS	180
	RESET	181
☒	Time Charts	182
	Time Charts	182

EtherNet/IP Communications Protocol

Data Exchange with Ethernet/IP

Data is exchanged cyclically between Ethernet devices on the EtherNet/IP network using tag data links as shown below.

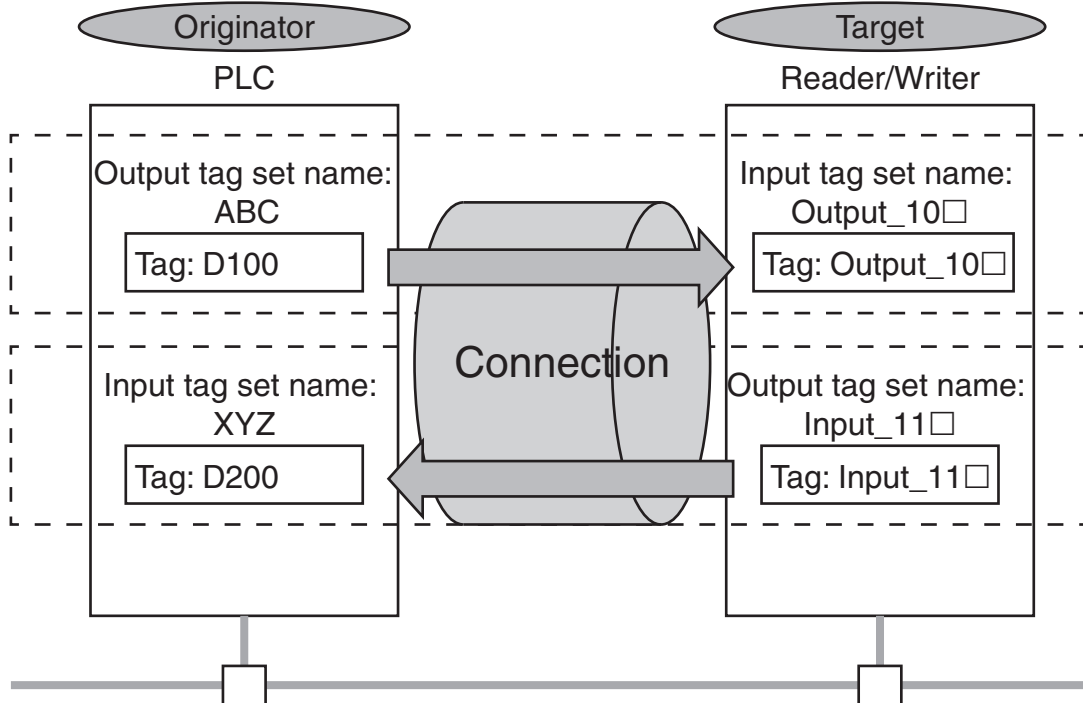

▪ Data Exchange Method

To exchange data, a connection is opened between two EtherNet/IP devices.

One of the nodes requests the connection to open a connection with a remote node. The node that requests the connection is called the originator, and the node that receives the request is called the target. The host device (PLC) and Reader/Writer function as the originator and target.

▪ Data Exchange Memory Locations

The memory locations that are used to exchange data across a connection are specified as tags.

You can specify memory addresses or variables in the host device (PLC) for tags.

A group of tags consists of an output tag set and an input tag set.

EtherNet/IP Communications with the Reader/Writer

You can use EtherNet/IP tag data links to communicate between the PLC and the Reader/Writer to perform control via command/response communications or to perform RF Tag communications. The following communications areas are prepared in the PLC to perform communications.

Area name	Description
Command Area	This is the area to which you write commands for the Reader/Writer to execute.
Response Area	This is the area to which the Reader/Writer writes the results of commands executed from the command area.

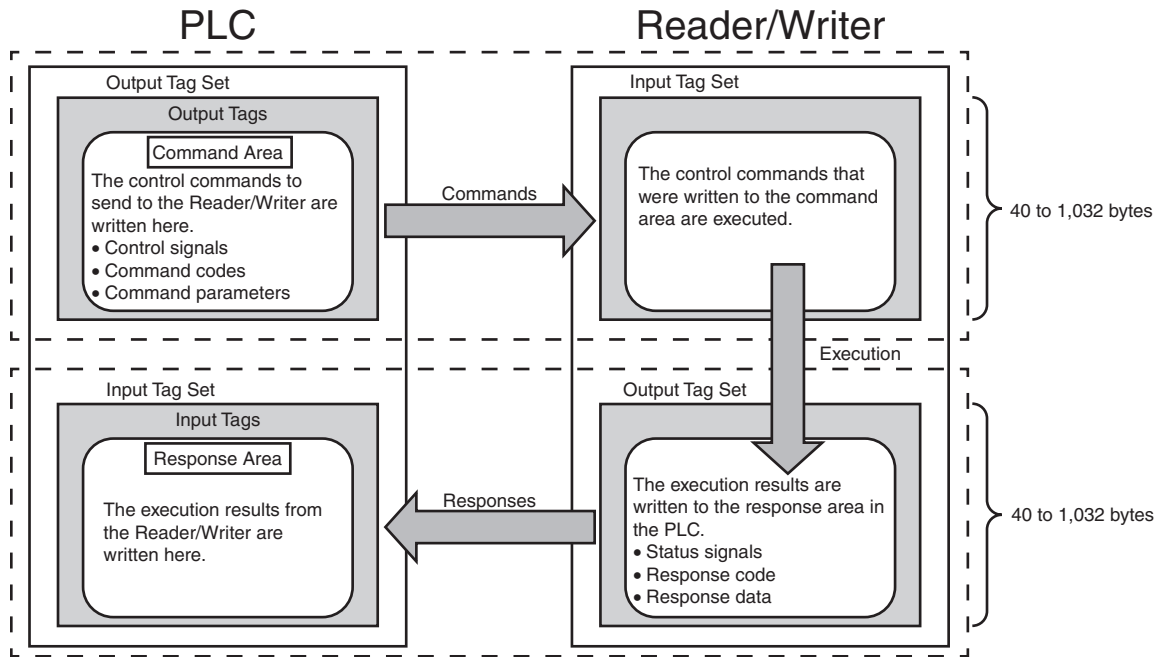

Tag Data Link Setting Methods

This section describes how to set data links for EtherNet/IP.

The communications areas in the PLC for which data links are created to the Reader/Writer are specified as tags and tag sets, and the connections are set for tag data link communications.

To connect to OMRON PLCs or Controllers, you use the Network Configurator to set up tag data links (i.e., tags, tag sets, and connection settings).

Refer to the following manuals for details on the tag data link settings that are made with the Network Configurator.

” NJ-series CPU Unit Built-in EtherNet/IP Port User’s Manual (Cat. No. W506)

” CS/CJ-series EtherNet/IP Units Operation Manual (Cat. No. W465)

” CJ-series EtherNet/IP Units Operation Manual for NJ-series CPU Unit (Cat. No. W495)



To set tag data links, an EDS file that defines the V680S connection is required. Download the EDS file from the OMRON website.

CHECK!

The communications areas in the PLC are set as tag data link connections as shown in the following table.

Tag and Tag Set Settings in the PLC

Setting item	Setting	
	Command Area	Response Area
Type of tags and tag set	Output tag sets	Input tag sets
Tag and tag set names	I/O memory addresses or variable names	I/O memory addresses or variable names
Data sizes	40, 264, 520, or 1,032 bytes*1	40, 264, 520, or 1,032 bytes*1

*1 Select one of the following values for the data size according to the data size required to write or read an RF Tag in one operation.

Data size	Data size that can be read or written for an RF Tag in one operation
40 bytes	32 bytes
264 bytes	256 bytes
520 bytes	512 bytes
1,032 bytes	1,024 bytes

Setting Connections

The screenshot shows the 'Setting Connections' window in the Network Configurator. It is divided into two main sections: 'Originator Device' and 'Target Device'.
Originator Device:
 - Connection I/O Type: Consume Data From/Produce Data To : 40
 - Node Address: 192.168.250.1
 - Comment: NJ501-1300
 - Input Tag Set: Edit Tag Sets
 - Connection Type: Point to Point connection
 - Output Tag Set: Edit Tag Sets
 - Connection Type: Point to Point connection
Target Device:
 - Node Address: 192.168.250.2
 - Comment: V680S Series
 - Output Tag Set: Input_200 - [40Byte]
 - Input Tag Set: Output_100 - [40Byte]
Detail Parameter:
 - Packet Interval (RP): 2.0 ms (10.0 - 10000.0 ms)
 - Timeout Value: Packet Interval (RP) x 4
 - Connection Name: (Possible to omit)

Setting item		Description
Originator device (PLC)	Input tag sets	Tag set name on PLC [40 to 1,032 bytes]
	Input connection types	Cannot be changed (point to point connection).
	Output tag sets	Tag set name on PLC [40 to 1,032 bytes]
	Output connection types	Cannot be changed (point to point connection).
Target device (Reader/Writer)	Output tag sets	Input_11□ [40 to 1,032 bytes]
	Input tag sets	Output_10□ [40 to 1,032 bytes]
Requested packet interval (RPI)		User specified (2.0 to 10,000 ms, default: 10.0 ms)



CHECK!

- If I/O memory addresses are specified for the communications areas, the information in the communications areas will be cleared when the operating mode of the PLC changes unless addresses in the CIO Area, which are maintained, are specified.
- The following assembly object is required to specify instances when the EDS file is not used.

Parameter name	Set value	Remarks
Instance ID	100	Output connection (40-byte tag set and tags)
	101	Output connection (264-byte tag set and tags)
	102	Output connection (520-byte tag set and tags)
	103	Output connection (1,032-byte tag set and tags)
	110	Input connection (40-byte tag set and tags)
	111	Input connection (264-byte tag set and tags)
	112	Input connection (520-byte tag set and tags)
	113	Input connection (1,032-byte tag set and tags)



CHECK!

- If you connect to an OMRON master, the maximum data size for one tag data link connection depends on the model of the master. Use the sizes in the following table for reference.

EtherNet/IP master	Maximum data size per connection	Recommended data size setting for tag or tag set.
NX701 CPU Unit	1,444 bytes	1,032 bytes
NJ-series CPU Unit	600 bytes	520 bytes
Built-in EtherNet/IP function on CJ2H-series CPU Unit	1,444 bytes	1,032 bytes
Built-in EtherNet/IP function on CJ2M-series CPU Unit	1,280 bytes	1,032 bytes
EtherNet/IP Unit	1,444 bytes	1,032 bytes

Memory Assignments

This section describes the memory assignments for the Command Area and Response Area in the PLC.

Memory is aligned in 16-bit units. The bit order for each field is little endian.

■ Command Area (from PLC Originator to Reader/Writer Target)

I/O memory offset	Bit															
	15	14	13	12	11	10	9	8	7	6	5	4	3	2	1	0
+0	Resv	Resv	Resv	Resv	Resv	Resv	Resv	Resv	Resv	Resv	Resv	Resv	Resv	Resv	Resv	EXE
+1	Command Code															
+2	Command Parameter 1															
+3	Command Parameter 2															
+4	Command Data (The format depends on the command.)															
:																
+N																

* Reserved (resv) bits are for future expansion. Do not turn them ON and OFF.

Signal/data	Name	Data type	Size	Description
EXE	Command Execution Request	BOOL	1 bit	<ul style="list-style-type: none"> • Turn ON this bit to send a request to the Reader/Writer to execute a command. Set the command code and parameters before you turn ON this bit. • You can turn OFF this bit during execution of a communications command with RF Tags to cancel communications processing by the Reader/Writer.
CmdCode	Command Code	WORD	2 bytes	This word stores the command code.
CmdParam1	Command Parameter 1	WORD	2 bytes	These words store the command parameters. Refer to the sections for individual commands for details.
CmdParam2	Command Parameter 2	WORD	2 bytes	
CmdData	Command Data	-	-	These words store the command data. Refer to the sections for individual commands for details.

▪ **Response Area (from Reader/Writer Target to PLC Originator)**

I/O memory offset	Bit															
	15	14	13	12	11	10	9	8	7	6	5	4	3	2	1	0
+0	Resv	Resv	Resv	Resv	Resv	Resv	Resv	RF_WAR	SYS_ER R	RF_ERR	CMD_ER R	FRIC	ERR	NOR M	BUS Y	REA DY
+1	Error code															
+2	Response Information 1															
+3	Response Information 2															
+4	Response Data (The format depends on the command.)															
:																
+N																

* Reserved (resv) bits are for future expansion. They always output 0.

Signal/data	Name	Data type	Size	Function
READY	Ready	BOOL	1 bit	This bit turns ON when the Reader/Writer completes preparations and is ready to receive a command. It turns OFF while tag data link communications are disconnected and the reconnecting Reader/Writer is executing a command.
BUSY	Command Execution Active	BOOL	1 bit	This bit is ON while the Reader/Writer is executing a command. It is OFF when a command is not being executed.
NORM	Command Completion	BOOL	1 bit	This bit turns ON when the Reader/Writer completes command execution normally (i.e., for a normal end). It turns OFF when the EXE signal is turned OFF.
ERR	Error	BOOL	1 bit	This bit turns ON when the Reader/Writer returns an error response. It turns OFF when the EXE signal is turned OFF.
FRIC	Flicker	BOOL	1 bit	This bit toggles (turns ON or turns OFF) when the communications result changes while the Reader/Writer is executing an RF Tag communications command with a Repeat communications option.
CMD_ERR	Command error	BOOL	1 bit	This bit turns ON when the Reader/Writer returns a command error response. It turns ON and OFF in sync with the ERR signal.
RF_ERR	RF Tag Communications Error	BOOL	1 bit	This bit turns ON when the Reader/Writer returns an RF Tag communications error response. It turns ON and OFF in sync with the ERR signal.
SYS_ERR	Fatal Error	BOOL	1 bit	This bit turns ON when the Reader/Writer returns a fatal error response. It turns ON and OFF in sync with the ERR signal.
RF_WAR	Unstable Communications	BOOL	1 bit	This bit turns ON when the diagnostics result in the response for execution of an RF Tag communications command by the Reader/Writer indicates that communications are unstable. It turns ON and OFF in sync with the NORM signal.
RespCode	Error Code	WORD	2 bytes	This word contains the error code.
RespInfo1	Response Information 1	WORD	2 bytes	This word contains device information.
RespInfo2	Response Information 2	WORD	2 bytes	This word contains communications diagnostic results.
RespData	Response Data	---	---	These words contain the response data. Refer to the sections for individual commands for details.

V680S Commands

■ Command Codes

The following table lists the command codes that you can specify for execution by the Reader/Writer. Set these codes in the Command Code field in the command area.

Classification	Command code	Command name	Reference
RF Tag communications	0001 hex	READ ID	Refer to page 156.
	0002 hex	READ DATA	Refer to page 157.
	0003 hex	WRITE DATA	Refer to page 158.
	0004 hex	LOCK	Refer to page 160.
	0005 hex	DATA FILL	Refer to page 159.
	0006 hex	RF TAG OVERWRITE COUNT CONTROL	Refer to page 161.
	0007 hex	RESTORE DATA	Refer to page 162.
	0008 hex	COPY DATA	Refer to page 163.
Reader/Writer settings	1000 hex	INITIALIZE	Refer to page 165.
	1001 hex	SET RF TAG COMMUNICATIONS	Refer to page 166.
	1002 hex	GET RF TAG COMMUNICATIONS SETTINGS	Refer to page 167.
	1003 hex	SET MULTI-READER/WRITER OPERATION	Refer to page 168.
	1004 hex	GET MULTI-READER/WRITER SETTINGS	Refer to page 170.
Reader/Writer information acquisition	2000 hex	GET MODEL INFORMATION	Refer to page 172.
	2001 hex	GET FIRMWARE VERSION	Refer to page 173.
	2002 hex	GET OPERATING TIME	Refer to page 174.
	2003 hex	MEASURE NOISE	Refer to page 175.
	2004 hex	GET COMMAND ERROR LOG	Refer to page 178.
	2005 hex	GET RESTORE INFORMATION	Refer to page 176.
	2006 hex	GET MULTI-READER/WRITER STATUS	Refer to page 180.
Reader/Writer operation control	3000 hex	RESET	Refer to page 181.

■ Error Codes

The following tables list the error codes that indicate the response results from the Reader/Writer. These codes are set in the Error Code field in the response area.

If an error response is returned (i.e., an error code other than 0000 hex), a record is stored in the command error log in the Reader/Writer. Records are not stored for errors for which responses are not returned to the host device. Reader/Writer operating errors and system errors are recorded in the system error log in the Reader/Writer.

■ Normal Code

Error code name	Error code	Description
Normal end	0000 hex	Processing ended normally.

■ Interrupted Processing

Error code name	Error code	Description
Communications canceled	0001 hex	Processing was canceled when an OFF EXE signal was received before an RF Tag was detected. (The contents of the RF Tag was not changed, even for a WRITE DATA command.)
Communications aborted	0002 hex	Processing was canceled when an OFF EXE signal was received during communications with an RF Tag. (For a WRITE DATA command, the contents of the RF Tag may have been changed.)

■ Command Errors

Error code name	Error code	Description
Unknown command error	1003 hex	A command that is not supported by the Reader/Writer was received.
Command parameter error	1005 hex	There was an error in the parameters in the received command data.
Execution status error	1006 hex	The Reader/Writer could not execute the command that was received.

■ RF Tag Communications Errors

Error code name	Error code	Description
RF Tag missing error	2001 hex	There is no RF Tag in the communications field.
RF Tag communications error	2002 hex	Communications with the RF Tag did not end normally.
UID mismatch error	2003 hex	An RF Tag with the specified ID was not in the communications field.
RF Tag address error	2004 hex	The access address for the RF Tag is outside of the area supported by the target RF Tag.
RF Tag lock error	2005 hex	An attempt was made to write data to a locked area.
Verification error	2006 hex	Processing to write data to the RF Tag did not end normally.
RF Tag data lost error	2007 hex	Processing to write data to the RF Tag did not end normally. (Data may have been lost and must be restored.)
RF Tag system error	2008 hex	The RF Tag returned an error response.
RF Tag overwriting error	2009 hex	The overwrite limit was exceeded for overwrite count control processing.
Reader/Writer connection error	200A hex	When executing the COPY DATA command, communications could not be established with the copy destination Reader/Writer.
Communications connection error between Reader/Writers	200B hex	When executing multi-Reader/Writer functions, communications could not be established with a Slave Reader/Writer.

■ Reader/Writer Operation Errors

Error code name	Error code	Description
Unfixed operation mode error	8001 hex	The control signal was not stable when the Reader/Writer was started. A record is stored only in the system error log.
User setting error	8002 hex	An error was detected in user configuration memory when the Reader/Writer was started. A record is stored only in the system error log. The classification of the setting is given in attached information 1. 0000 0001 hex: Network setting 0000 0002 hex: RF Tag communications setting 0000 0003 hex: Multi-Reader/Writer setting
Multi-Reader/Writer execution error	8003 hex	A set value was detected when the Reader/Writer was started that prevents execution of multi-Reader/Writer operation. The reason for the error is given in attached information 1. 0000 0001 hex: The combination of the Multi-Reader/Writer Mode and the communications option prevented execution. 0000 0002 hex: This Reader/Writer has the same IP address as the Slave Reader/Writer.

■ System Errors

Error code name	Error code	Description
System startup errors		
System memory error	F001 hex	An error was detected in system memory. A record is stored only in the system error log.
Profile error	F002 hex	An error was detected in the profile data. A record is stored only in the system error log.
Hardware faults		
IC error	F011 hex	An error was detected in an IC in the Reader/Writer.
Configuration memory error	F012 hex	An error was detected when accessing configuration memory.

■ Device Information

The following table lists the device information that indicates the Reader/Writer in which the error occurred.

These codes are set in the Response Information 1 field in the response area.

Device information	Description
0000 hex	An error occurred in the local Reader/Writer.
0100 hex	<ul style="list-style-type: none"> An error occurred in the destination Reader/Writer when copying data. An error occurred in Slave Reader/Writer No. 1 for multi-Reader/Writer operation.
0200 hex	An error occurred in Slave Reader/Writer No. 2 for multi-Reader/Writer operation.
0300 hex	An error occurred in Slave Reader/Writer No. 3 for multi-Reader/Writer operation.
0400 hex	An error occurred in Slave Reader/Writer No. 4 for multi-Reader/Writer operation.
0500 hex	An error occurred in Slave Reader/Writer No. 5 for multi-Reader/Writer operation.
0600 hex	An error occurred in Slave Reader/Writer No. 6 for multi-Reader/Writer operation.
0700 hex	An error occurred in Slave Reader/Writer No. 7 for multi-Reader/Writer operation.

■ Communications Diagnostics Results

The following table lists the communications diagnostic results that are obtained when the Reader/Writer communicates with an RF Tag.

If communications diagnostics are enabled, these codes are provided to indicate the cause when diagnostics indicate that communications are unstable.

This information is set in the Response Information 2 field in the response area. When this information is set, the RF_WAR (communications unstable) signal turns ON.

Communications diagnostics result	Description
0000 hex	Normal
0001 hex	Insufficient power to send
0002 hex	Insufficient power to receive
0003 hex	Too much noise
0004 hex	Insufficient signal-to-noise ratio

V680S Command Details

READ ID

This command reads the ID code of the RF Tag in the communications field.

Command Area

Signal/data	Data type	Size	Description
CmdCode/Command Code	WORD	2 bytes	0001 hex
CmdParam1/Command Parameter 1	WORD	2 bytes	0000 hex (Not used.)
CmdParam2/Command Parameter 2	WORD	2 bytes	0000 hex (Not used.)

Response Area

Signal/data	Data type	Size	Description
ErrCode/Error Code	WORD	2 bytes	Error code
RespInfo1/Response Information 1	WORD	2 bytes	Device information
RespInfo2/Response Information 2	WORD	2 bytes	Communications diagnostics result
RespData/Response Data	STRUCT	-	-
ID Data	ARRAY[] OF BYTE	8 bytes	UID data read from the RF Tag (always 8 bytes)

Execution Example

Reading the ID Code of the RF Tag

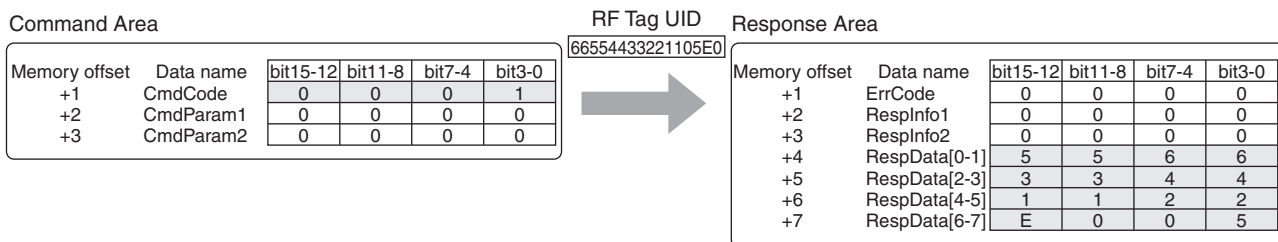

READ DATA

This command reads data from the RF Tag in the communications field.

Command Area

Signal/data	Data type	Size	Function
CmdCode/Command Code	WORD	2 bytes	0002 hex
CmdParam1/Command Parameter 1	WORD	2 bytes	First word address of the data read from the RF Tag 0000 to FFFF hex
CmdParam2/Command Parameter 2	WORD	2 bytes	The maximum data size that you can read from an RF Tag depends on the data size setting (in words). 0000 to 0200 hex * The maximum size that you can specify depends on the tag data link settings.

Response Area

Signal/data	Data type	Size	Function
ErrCode/Error Code	WORD	2 bytes	Error code
RespInfo1/Response Information 1	WORD	2 bytes	Error device information
RespInfo2/Response Information 2	WORD	2 bytes	Communications diagnostics result
RespData/Response Data			
Read data	ARRAY[] OF BYTE	1,024 bytes max.	Data read from the RF Tag

Execution Example

Reading Four Words of Data Starting from Word Address 1234 Hex in the RF Tag

Command Area

Memory offset	Data name	bit15-12	bit11-8	bit7-4	bit3-0
+1	CmdCode	0	0	0	2
+2	CmdParam1	1	2	3	4
+3	CmdParam2	0	0	0	4

RF Tag Memory

User address	bit15-12	bit11-8	bit7-4	bit3-0
1234Hex	1	1	1	1
1235Hex	2	2	2	2
1236Hex	3	3	3	3
1235Hex	4	4	4	4



Response Area

Memory offset	Data name	bit15-12	bit11-8	bit7-4	bit3-0
+1	ErrCode	0	0	0	0
+2	RespInfo1	0	0	0	0
+3	RespInfo2	0	0	0	0
+4	RespData[0-1]	1	1	1	1
+5	RespData[2-3]	2	2	2	2
+6	RespData[4-5]	3	3	3	3
+7	RespData[6-7]	4	4	4	4

WRITE DATA

This command writes data to the RF Tag in the communications field.

Command Area

Signal/data	Data type	Size	Function
CmdCode/Command Code	WORD	16 bits	WRITE DATA (0003 hex)
CmdParam1/Command Parameter 1	WORD	16 bits	First word address of the data to write to the RF Tag 0000 to FFFF hex
CmdParam2/Command Parameter 2	WORD	16 bits	The maximum data size that you can write to an RF Tag depends on the data size setting (in words). 0000 to 0200 hex * The maximum size that you can specify depends on the tag data link settings.
CmdData/Command Data			
Data to write	ARRAY[] OF WORD	1,024 bytes max.	Data to write to RF Tag

Response Area

Signal/data	Data type	Size	Function
ErrCode/Response Code	WORD	2 bytes	Error code
ResplInfo1/Response Information 1	WORD	2 bytes	Error device information
ResplInfo2/Response Information 2	WORD	2 bytes	Communications diagnostics result

Execution Example

Writing 1111222233334444 to Four Words Starting from Word Address 1234 Hex in the RF Tag

Command Area

Memory offset	Data name	bit15-12	bit11-8	bit7-4	bit3-0
+1	CmdCode	0	0	0	3
+2	CmdParam1	1	2	3	4
+3	CmdParam2	0	0	0	4
+4	CmdData[0-1]	1	1	1	1
+5	CmdData[2-3]	2	2	2	2
+6	CmdData[4-5]	3	3	3	3
+7	CmdData[6-7]	4	4	4	4

Response Area

Memory offset	Data name	bit15-12	bit11-8	bit7-4	bit3-0
+1	ErrCode	0	0	0	0
+2	ResplInfo1	0	0	0	0
+3	ResplInfo2	0	0	0	0

RF Tag Memory

User address	bit15-12	bit11-8	bit7-4	bit3-0
1234Hex	1	1	1	1
1235Hex	2	2	2	2
1236Hex	3	3	3	3
1235Hex	4	4	4	4

LOCK

This command locks the memory of the RF Tag in the communications field. Memory cannot be written again after it is locked. There is also no way to unlock memory.

Command Area

Signal/data	Data type	Size	Function
CmdCode/Command Code	WORD	2 bytes	0004 hex
CmdParam1/Command Parameter 1	WORD	2 bytes	First block or sector number to lock in the RF Tag 0000 to FFFF hex
CmdParam2/Command Parameter 2	WORD	2 bytes	Number of blocks or sectors to lock in the RF Tag 0001 to FFFF hex

Response Area

Signal/data	Data type	Size	Function
ErrCode/Error Code	WORD	2 bytes	Error code
Resplnfo1/Response Information 1	WORD	2 bytes	Error device information
Resplnfo2/Response Information 2	WORD	2 bytes	Communications diagnostics result

Execution Example

Locking Four Blocks/Sectors Starting from Block/Sector 12 in the RF Tag

Command Area

Memory offset	Data name	bit15-12	bit11-8	bit7-4	bit3-0
+1	CmdCode	0	0	0	4
+2	CmdParam1	0	0	0	C
+3	CmdParam2	0	0	0	4

Response Area

Memory offset	Data name	bit15-12	bit11-8	bit7-4	bit3-0
+1	ErrCode	0	0	0	0
+2	Resplnfo1	0	0	0	0
+3	Resplnfo2	0	0	0	0



The unit for locking memory depends on the RF Tag.
Refer to *RF Tag Memory Map* in *Section 11 Appendices* for details.

CHECK!



p.299

DATA FILL

This command fills the specified number of words in the RF Tag in the communications field with the specified data.

Command Area

Signal/data	Data type	Size	Function
CmdCode/Command Code	WORD	2 bytes	0005 hex
CmdParam1/Command Parameter 1	WORD	2 bytes	First word address of the data to write to the RF Tag 0000 to FFFF hex
CmdParam2/Command Parameter 2	WORD	2 bytes	Number of words in the RF Tag to write 0000 hex: Specifies the entire area. 0001 to FFFF hex: Specified size
CmdData/Command Data			
Fill data	ARRAY[] OF BYTE	2 bytes	Fill data to write to the RF Tag (always one word)

Response Area

Signal/data	Data type	Size	Function
ErrCode/Error Code	WORD	2 bytes	Error code
ResplInfo1/Response Information 1	WORD	2 bytes	Device information
ResplInfo2/Response Information 2	WORD	2 bytes	Communications diagnostics result

Execution Example

Writing 5A5A Hex to Four Words Starting from Word Address 1234 Hex in the RF Tag

Command Area

Memory offset	Data name	bit15-12	bit11-8	bit7-4	bit3-0
+1	CmdCode	0	0	0	5
+2	CmdParam1	1	2	3	4
+3	CmdParam2	0	0	0	4
+4	CmdData[0-1]	5	A	5	A



Response Area

Memory offset	Data name	bit15-12	bit11-8	bit7-4	bit3-0
+1	ErrCode	0	0	0	0
+2	ResplInfo1	0	0	0	0
+3	ResplInfo2	0	0	0	0

RF Tag Memory

User address	bit15-12	bit11-8	bit7-4	bit3-0
1234Hex	5	A	5	A
1235Hex	5	A	5	A
1236Hex	5	A	5	A
1235Hex	5	A	5	A

RF TAG OVERWRITE COUNT CONTROL

This command is used to control the number of times RF Tags are overwritten. You can use it for RF Tags that have EEPROM.

Command Area

Signal/data	Data type	Size	Function
CmdCode/Command Code	WORD	2 bytes	0006 hex
CmdParam1/Command Parameter 1	WORD	2 bytes	Overwrite count control operation 0x0000: Initialization 0x0001: Subtraction 0x0002: Addition
CmdParam2/Command Parameter 2	WORD	2 bytes	First word address of the overwrite count area to maintain in the RF Tag 0000 to FFFF hex
CmdData/Command Data			
Count	UDINT	4 bytes	Initialize: The overwrite count to set in the RF Tag Addition/Subtraction: The count to add to or subtract from the current value maintained in the RF Tag 0000 0000 to FFFF FFFF hex

Response Area

Signal/data	Data type	Size	Function
ErrCode/Error Code	WORD	2 bytes	Error code
RespInfo1/Response Information 1	WORD	2 bytes	Device information
RespInfo2/Response Information 2	WORD	2 bytes	Communications diagnostics result

Execution Example

Initializing Word Address 1234 Hex in the RF Tag to a Count of 5,000 (1388 Hex) as the Overwrite Count Area

Command Area

Memory offset	Data name	bit15-12	bit11-8	bit7-4	bit3-0
+1	CmdCode	0	0	0	6
+2	CmdParam1	0	0	0	0
+3	CmdParam2	1	2	3	4
+4	CmdData[0-1]	1	3	8	8
+5	CmdData[2-3]	0	0	0	0



Response Area

Memory offset	Data name	bit15-12	bit11-8	bit7-4	bit3-0
+1	ErrCode	0	0	0	0
+2	RespInfo1	0	0	0	0
+3	RespInfo2	0	0	0	0

RF Tag Memory

User address	bit15-12	bit11-8	bit7-4	bit3-0
1234Hex	0	0	0	0
1235Hex	1	3	8	8

RESTORE DATA

This command restores the RF Tag data that is held in the Reader/Writer. You can use it for RF Tags that have EEPROM.

You can restore RF Tag data only when the RF Tag in the communications field matches the held RF Tag ID.

Command Area

Signal/data	Data type	Size	Function
CmdCode/Command Code	WORD	2 bytes	0007 hex
CmdParam1/Command Parameter 1	WORD	2 bytes	0000 hex (Not used.)
CmdParam2/Command Parameter 2	WORD	2 bytes	0000 hex (Not used.)

Response Area

Signal/data	Data type	Size	Function
ErrCode/Error Code	WORD	2 bytes	Error code
ResplInfo1/Response Information 1	WORD	2 bytes	Error device information
ResplInfo2/Response Information 2	WORD	2 bytes	Communications diagnostics result

Execution Example

Restoring Data When Writing to an RF Tag Fails and an RF Tag Data Lost Error Occurs

Command Area

Memory offset	Data name	bit15-12	bit11-8	bit7-4	bit3-0
+1	CmdCode	0	0	0	7
+2	CmdParam1	0	0	0	0
+3	CmdParam2	0	0	0	0

Response Area

Memory offset	Data name	bit15-12	bit11-8	bit7-4	bit3-0
+1	ErrCode	0	0	0	0
+2	ResplInfo1	0	0	0	0
+3	ResplInfo2	0	0	0	0

Information to Restore

User address	1234	
Data size	0004	
Data	11	22
	33	44
	55	66
	77	88

RF Tag Memory

User address	bit15-12	bit11-8	bit7-4	bit3-0
1234Hex	1	1	2	2
1235Hex	3	3	4	4
1236Hex	5	5	6	6
1235Hex	7	7	8	8

COPY DATA

This command uses two Reader/Writers to copy data from an RF Tag in the communications field of one Reader/Writer (A) to the RF Tag in the communications field of another Reader/Writer (B).

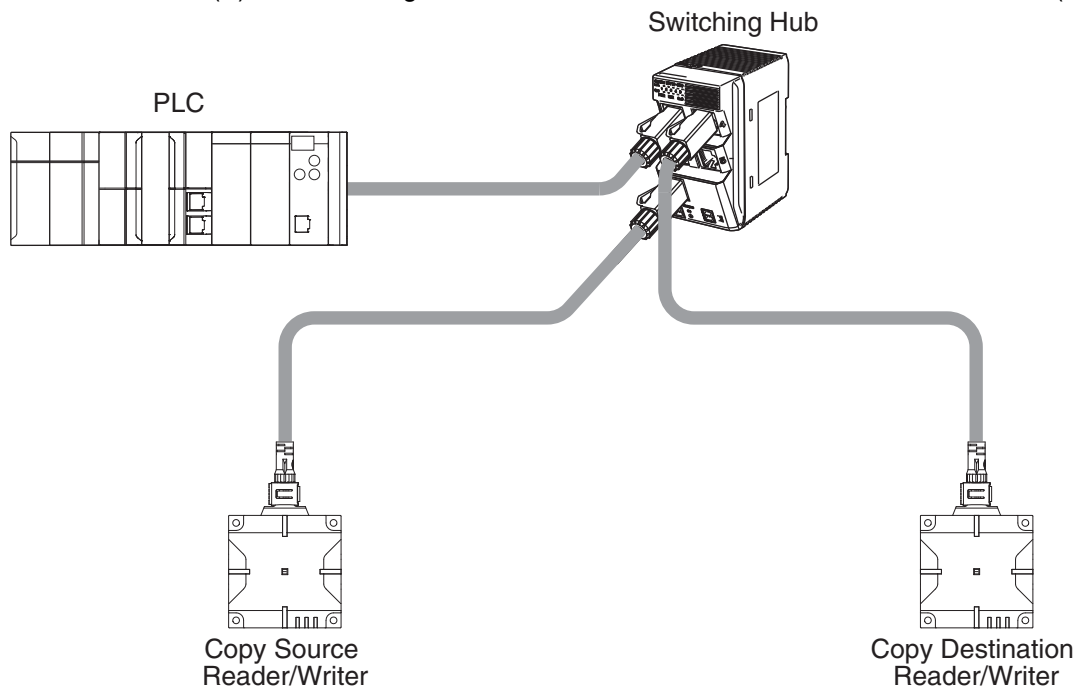

Command Area

Signal/data	Data type	Size	Function
CmdCode/Command Code	WORD	2 bytes	0008 hex
CmdParam1/Command Parameter 1	WORD	2 bytes	First word address of the data to copy from the RF Tag 0000 to FFFF hex
CmdParam2/Command Parameter 2	WORD	2 bytes	Number of words in the RF Tag to copy 0001 to 0200 hex
CmdData/Command Data			
IP address	DWORD	4 bytes	IP address of Reader/Writer at the copy destination 0000 0000 to FFFF FFFF hex Example: C0A801C8 hex (192.168.1.200)

Response Area

Signal/data	Data type	Size	Function
ErrCode/Error Code	WORD	2 bytes	Error code
RespInfo1/Response Information 1	WORD	2 bytes	Device information
RespInfo2/Response Information 2	WORD	2 bytes	Communications diagnostics result

▪ **Execution Example**

Copying Four Words of Data Starting from Word Address 1234 Hex in the RF Tag to an RF Tag in the Communications Field of the Reader/Writer with IP Address 192.168.1.201 (C0A801C9 Hex)

Command Area

Memory offset	Data name	bit15-12	bit11-8	bit7-4	bit3-0
+1	CmdCode	0	0	0	8
+2	CmdParam1	1	2	3	4
+3	CmdParam2	0	0	0	4
+4	CmdData[0-1]	0	1	C	9
+5	CmdData[2-3]	C	0	A	8

Response Area

Memory offset	Data name	bit15-12	bit11-8	bit7-4	bit3-0
+1	ErrCode	0	0	0	0
+2	ResplInfo1	0	0	0	0
+3	ResplInfo2	0	0	0	0

RF Tag Memory in the Copy Source Reader/Writer

User address	bit15-12	bit11-8	bit7-4	bit3-0
1234Hex	1	1	2	2
1235Hex	3	3	4	4
1236Hex	5	5	6	6
1235Hex	7	7	8	8

RF Tag Memory in the Copy Destination Reader/Writer

User address	bit15-12	bit11-8	bit7-4	bit3-0
1234Hex	1	1	2	2
1235Hex	3	3	4	4
1236Hex	5	5	6	6
1235Hex	7	7	8	8

The operation indicator on the copy source Reader/Writer will change as shown in the following table.

		Copy destination		
		Communications normal (stable communications): Indicator lights green.	Communications normal (unstable communications): Indicator lights yellow.	Communications failed: Indicator lights red.
Copy source	Communications normal (stable communications): Indicator lights green.	Communications normal (stable communications): Indicator lights green.	Communications normal (unstable communications): Indicator lights yellow.	Communications failed: Indicator lights red.
	Communications normal (unstable communications): Indicator lights yellow.	Communications normal (unstable communications): Indicator lights yellow.	Communications normal (unstable communications): Indicator lights yellow.	Communications failed: Indicator lights red.
	Communications failed: Indicator lights red.	Communications failed: Indicator lights red.	Communications failed: Indicator lights red.	Communications failed: Indicator lights red.



To check the communications diagnostics result of the copy destination Reader/Writer, use the Web server function to check the copy destination Reader/Writer separately.

CHECK!

Refer to *Web Server* in *Section 6 Functions* for detailed information on Web server function.



p.107

INITIALIZE

This command restores the Reader/Writer settings to their default values.

Command Area

Signal/data	Data type	Size	Function
CmdCode/Command Code	WORD	2 bytes	1000 hex
CmdParam1/Command Parameter 1	WORD	2 bytes	0000 hex (Not used.)
CmdParam2/Command Parameter 2	WORD	2 bytes	0000 hex (Not used.)

Response Area

Signal/data	Data type	Size	Function
ErrCode/Error Code	WORD	2 bytes	Error code
RespInfo1/Response Information 1	WORD	2 bytes	0000 hex (Not used.)
RespInfo2/Response Information 2	WORD	2 bytes	0000 hex (Not used.)

Execution Example

Initializing All Settings

Command Area

Memory offset	Data name	bit15-12	bit11-8	bit7-4	bit3-0
+1	CmdCode	1	0	0	0
+2	CmdParam1	0	0	0	0
+3	CmdParam2	0	0	0	0



Response Area

Memory offset	Data name	bit15-12	bit11-8	bit7-4	bit3-0
+1	ErrCode	0	0	0	0
+2	RespInfo1	0	0	0	0
+3	RespInfo2	0	0	0	0

SET RF TAG COMMUNICATIONS

This command sets the RF Tag communications conditions in the Reader/Writer (communications option, communications speed, and write verification).

Command Area

Signal/data	Data type	Size	Function
CmdCode/Command Code	WORD	2 bytes	1001 hex
CmdParam1/Command Parameter 1	WORD	2 bytes	0000 hex (Not used.)
CmdParam2/Command Parameter 2	WORD	2 bytes	0000 hex (Not used.)
CmdData/Command Data			
Communications Option	WORD	2 bytes	0000 hex: Once 0001 hex: Repeat 0002 hex: FIFO Repeat (Without ID code check) 0003 hex: Auto 0012 hex: FIFO Repeat (With ID code check)
Communications Speed	WORD	2 bytes	0000 hex: High speed 0001 hex: Normal speed
Write Verification	WORD	2 bytes	0000 hex: Do not verify. 0001 hex: Verify
Communications Diagnostics	WORD	2 bytes	0000 hex: Disable 0001 hex: Enable

Response Area

Signal/data	Data type	Size	Function
ErrCode/Error Code	WORD	2 bytes	Error code
ResplInfo1/Response Information 1	WORD	2 bytes	0000 hex (Not used.)
ResplInfo2/Response Information 2	WORD	2 bytes	0000 hex (Not used.)

Execution Example

Setting the Communications Option to Repeat, Setting the Communications Speed to Standard, Disabling Write Verification, and Enabling Communications Diagnostics

Command Area

Memory offset	Data name	bit15-12	bit11-8	bit7-4	bit3-0
+1	CmdCode	1	0	0	1
+2	CmdParam1	0	0	0	0
+3	CmdParam2	0	0	0	0
+4	CmdData[0-1]	0	0	0	1
+5	CmdData[2-3]	0	0	0	1
+6	CmdData[4-5]	0	0	0	0
+7	CmdData[6-7]	0	0	0	1



Response Area

Memory offset	Data name	bit15-12	bit11-8	bit7-4	bit3-0
+1	ErrCode	0	0	0	0
+2	ResplInfo1	0	0	0	0
+3	ResplInfo2	0	0	0	0

GET RF TAG COMMUNICATIONS SETTINGS

This command reads the RF Tags communications conditions from the Reader/Writer (communications option, communications speed, and write verification).

Command Area

Signal/data	Data type	Size	Function
CmdCode/Command Code	WORD	2 bytes	1002 hex
CmdParam1/Command Parameter 1	WORD	2 bytes	0000 hex (Not used.)
CmdParam2/Command Parameter 2	WORD	2 bytes	0000 hex (Not used.)

Response Area

Signal/data	Data type	Size	Function
ErrCode/Error Code	WORD	2 bytes	Error code
RespInfo1/Response Information 1	WORD	2 bytes	0000 hex (Not used.)
RespInfo2/Response Information 2	WORD	2 bytes	0000 hex (Not used.)
RespData/Response Data			
Communications Option	WORD	2 bytes	0000 hex: Once 0001 hex: Repeat 0002 hex: FIFO Repeat (Without ID code check) 0003 hex: Auto 0012 hex: FIFO Repeat (With ID code check)
Communications Speed	WORD	2 bytes	0000 hex: High speed 0001 hex: Normal speed
Write Verification	WORD	2 bytes	0000 hex: Do not verify. 0001 hex: Verify
Communications Diagnostics	WORD	2 bytes	0000 hex: Disable 0001 hex: Enable

Execution Example

Reading the Communications Settings When the Communications Option Is Set to Repeat, the Communications Speed Is Set to Standard, Write Verification Is Disabled, and Communications Diagnostics Are Enabled

Command Area

Memory offset	Data name	bit15-12	bit11-8	bit7-4	bit3-0
+1	CmdCode	1	0	0	2
+2	CmdParam1	0	0	0	0
+3	CmdParam2	0	0	0	0



Response Area

Memory offset	Data name	bit15-12	bit11-8	bit7-4	bit3-0
+1	ErrCode	0	0	0	0
+2	RespInfo1	0	0	0	0
+3	RespInfo2	0	0	0	0
+4	RespData[0-1]	0	0	0	1
+5	RespData[2-3]	0	0	0	1
+6	RespData[4-5]	0	0	0	0
+7	RespData[6-7]	0	0	0	1

SET MULTI-READER/WRITER OPERATION

This command sets multi-Reader/Writer operation.

Command Area

Signal/data	Data type	Size	Function
CmdCode/Command Code	WORD	2 bytes	1003 hex
CmdParam1/Command Parameter 1	WORD	2 bytes	0000 hex (Not used.)
CmdParam2/Command Parameter 2	WORD	2 bytes	0000 hex (Not used.)
RespData/Response Data			
Multi-Reader/Writer Mode	WORD	2 bytes	0000 hex: Disable 0001 hex: Enable Field Extension Mode 0002 hex: Enable High-speed Traveling Mode
Number of Slave Reader/Writers	WORD	2 bytes	Number of Reader/Writers linked with multi-Reader/Writer operation 0000 to 0007 hex * Specify 0000 hex if multi-Reader/Writer operation is disabled.
IP Address of Slave Reader/Writer No. 1	DWORD	4 bytes	IP addresses of Slave Reader/Writers 0000 0000 to FFFF FFFF hex Example: C0A801C8 hex (192.168.1.200) * Specify 0000 0000 hex if multi-Reader/Writer operation is disabled or the Slave Reader/Writer is not used.
IP Address of Slave Reader/Writer No. 2	DWORD	4 bytes	
IP Address of Slave Reader/Writer No. 3	DWORD	4 bytes	
IP Address of Slave Reader/Writer No. 4	DWORD	4 bytes	
IP Address of Slave Reader/Writer No. 5	DWORD	4 bytes	
IP Address of Slave Reader/Writer No. 6	DWORD	4 bytes	
IP Address of Slave Reader/Writer No. 7	DWORD	4 bytes	

Response Area

Signal/data	Data type	Size	Function
ErrCode/Error Code	WORD	2 bytes	Error code
RespInfo1/Response Information 1	WORD	2 bytes	0000 hex (Not used.)
RespInfo2/Response Information 2	WORD	2 bytes	0000 hex (Not used.)

▪ **Execution Example**

Setting the Multi-Reader/Writer Mode to Field Extension Mode, the Number of Slave Reader/Writers to 3, and the IP Addresses of Slaves No. 1, No. 2, and No. 3 to 192.168.1.201, 192.168.1.202, and 192.168.1.203, Respectively

Command Area

Memory offset	Data name	bit15-12	bit11-8	bit7-4	bit3-0
+1	CmdCode	1	0	0	3
+2	CmdParam1	0	0	0	0
+3	CmdParam2	0	0	0	0
+4	CmdData[0-1]	0	0	0	1
+5	CmdData[2-3]	0	0	0	3
+6	CmdData[4-5]	0	1	C	9
+7	CmdData[6-7]	C	0	A	8
+8	CmdData[8-9]	0	1	C	A
+9	CmdData[10-11]	C	0	A	8
+10	CmdData[12-13]	0	1	C	B
+11	CmdData[14-15]	C	0	A	8
+12	CmdData[16-17]	0	0	0	0
+13	CmdData[18-19]	0	0	0	0
+14	CmdData[20-21]	0	0	0	0
+15	CmdData[22-23]	0	0	0	0
+16	CmdData[24-25]	0	0	0	0
+17	CmdData[26-27]	0	0	0	0
+18	CmdData[28-29]	0	0	0	0
+19	CmdData[30-31]	0	0	0	0



Response Area

Memory offset	Data name	bit15-12	bit11-8	bit7-4	bit3-0
+1	ErrCode	0	0	0	0
+2	ResplInfo1	0	0	0	0
+3	ResplInfo2	0	0	0	0

} IP address of Slave Reader/Writer No. 1
 } IP address of Slave Reader/Writer No. 2
 .
 .
 .
 } IP address of Slave Reader/Writer No. 6
 } IP address of Slave Reader/Writer No. 7

GET MULTI-READER/WRITER SETTINGS

You can use this command to check the multi-Reader/Writer settings in a Reader/Writer.

Command Area

Signal/data	Data type	Size	Function
CmdCode/Command Code	WORD	2 bytes	1004 hex
CmdParam1/Command Parameter 1	WORD	2 bytes	0000 hex (Not used.)
CmdParam2/Command Parameter 2	WORD	2 bytes	0000 hex (Not used.)

Response Area

Signal/data	Data type	Size	Function
ErrCode/Error Code	WORD	2 bytes	Error code
RespInfo1/Response Information 1	WORD	2 bytes	0000 hex (Not used.)
RespInfo2/Response Information 2	WORD	2 bytes	0000 hex (Not used.)
RespData/Response Data			
Multi-Reader/Writer Mode	WORD	2 bytes	0000 hex: Disable 0001 hex: Enable Field Extension Mode 0002 hex: Enable High-speed Traveling Mode
Number of Slave Reader/Writers	WORD	2 bytes	Number of Reader/Writers linked with multi-Reader/Writer operation 0000 to 0007 hex
IP Address of Slave Reader/Writer No. 1	DWORD	4 bytes	IP addresses of Slave Reader/Writers 0000 0000 to FFFF FFFF hex Example: C0A801C8 hex (192.168.1.200)
IP Address of Slave Reader/Writer No. 2	DWORD	4 bytes	
IP Address of Slave Reader/Writer No. 3	DWORD	4 bytes	
IP Address of Slave Reader/Writer No. 4	DWORD	4 bytes	
IP Address of Slave Reader/Writer No. 5	DWORD	4 bytes	
IP Address of Slave Reader/Writer No. 6	DWORD	4 bytes	
IP Address of Slave Reader/Writer No. 7	DWORD	4 bytes	

▪ Execution Example

Reading the Multi-Reader/Writer Settings When the Multi-Reader/Writer Mode Is Set to Field Extension Mode, the Number of Slave Reader/Writers Is Set to 3, and the IP Addresses of Slaves No. 1, No. 2, and No. 3 Are Set to 192.168.1.201, 192.168.1.202, and 192.168.1.203, Respectively

Command Area

Memory offset	Data name	bit15-12	bit11-8	bit7-4	bit3-0
+1	CmdCode	1	0	0	4
+2	CmdParam1	0	0	0	0
+3	CmdParam2	0	0	0	0



Response Area

Memory offset	Data name	bit15-12	bit11-8	bit7-4	bit3-0
+1	ErrCode	0	0	0	0
+2	RespInfo1	0	0	0	0
+3	RespInfo2	0	0	0	0
+4	RespData[0-1]	0	1	0	0
+5	RespData[2-3]	0	3	0	0
+6	RespData[4-5]	0	1	C	9
+7	RespData[6-7]	C	0	A	8
+8	RespData[8-9]	0	1	C	A
+9	RespData[10-11]	C	0	A	8
+10	RespData[12-13]	0	1	C	B
+11	RespData[14-15]	C	0	A	8
+12	RespData[16-17]	0	0	0	0
+13	RespData[18-19]	0	0	0	0
+14	RespData[20-21]	0	0	0	0
+15	RespData[22-23]	0	0	0	0
+16	RespData[24-25]	0	0	0	0
+17	RespData[26-27]	0	0	0	0
+18	RespData[28-29]	0	0	0	0
+19	RespData[30-31]	0	0	0	0

} IP address of Slave Reader/Writer No. 1
 } IP address of Slave Reader/Writer No. 2
 } IP address of Slave Reader/Writer No. 2

GET MODEL INFORMATION

This command reads the model of the Reader/Writer.

Command Area

Signal/data	Data type	Size	Function
CmdCode/Command Code	WORD	2 bytes	2000 hex
CmdParam1/Command Parameter 1	WORD	2 bytes	0000 hex (Not used.)
CmdParam2/Command Parameter 2	WORD	2 bytes	0000 hex (Not used.)

Response Area

Signal/data	Data type	Size	Function
ErrCode/Error Code	WORD	2 bytes	Error code
RespInfo1/Response Information 1	WORD	2 bytes	0000 hex (Not used.)
RespInfo2/Response Information 2	WORD	2 bytes	0000 hex (Not used.)
RespData/Response Data			
Model Number Information	ARRAY[] OF BYTE	32 bytes	32 bytes of ASCII text max. (end code: 0000 hex)

Execution Example

Reading the Model When a V680S-HMD63-EIP Reader/Writer Is Being Used

Command Area

Memory offset	Data name	bit15-12	bit11-8	bit7-4	bit3-0
+1	CmdCode	2	0	0	0
+2	CmdParam1	0	0	0	0
+3	CmdParam2	0	0	0	0



Response Area

Memory offset	Data name	bit15-12	bit11-8	bit7-4	bit3-0
+1	ErrCode	0	0	0	0
+2	RespInfo1	0	0	0	0
+3	RespInfo2	0	0	0	0
+4	RespData[0-1]	3	6	5	6
+5	RespData[2-3]	3	0	3	8
+6	RespData[4-5]	2	D	5	3
+7	RespData[6-7]	4	D	4	8
+8	RespData[8-9]	3	6	4	4
+9	RespData[10-11]	2	D	3	3
+10	RespData[12-13]	4	9	4	5
+11	RespData[14-15]	0	0	5	0
+12	RespData[16-17]	0	0	0	0
+13	RespData[18-19]	0	0	0	0
+14	RespData[20-21]	0	0	0	0
+15	RespData[22-23]	0	0	0	0
+16	RespData[24-25]	0	0	0	0
+17	RespData[26-27]	0	0	0	0
+18	RespData[28-29]	0	0	0	0
+19	RespData[30-31]	0	0	0	0

Model number information obtained from Reader/Writer

GET FIRMWARE VERSION

This command reads the firmware version of the Reader/Writer.

Command Area

Signal/data	Data type	Size	Function
CmdCode/Command Code	WORD	2 bytes	2001 hex
CmdParam1/Command Parameter 1	WORD	2 bytes	0000 hex (Not used.)
CmdParam2/Command Parameter 2	WORD	2 bytes	0000 hex (Not used.)

Response Area

Signal/data	Data type	Size	Function
ErrCode/Error code	WORD	2 bytes	Error code
RespInfo1/Response Information 1	WORD	2 bytes	0000 hex (Not used.)
RespInfo2/Response Information 2	WORD	2 bytes	0000 hex (Not used.)
RespData/Response Data			
Run Mode Program Major Version	WORD	2 bytes	0000 to 0099 hex (BCD)
Run Mode Program Minor Version	WORD	2 bytes	0000 to 0099 hex (BCD)
Run Mode Program Revision	WORD	2 bytes	0000 to 9999 hex (BCD)
Safe Mode Program Major Version	WORD	2 bytes	0000 to 0099 hex (BCD)
Safe Mode Program Minor Version	WORD	2 bytes	0000 to 0099 hex (BCD)
Safe Mode Program Revision	WORD	2 bytes	0000 to 9999 hex (BCD)

Execution Example

Reading the Firmware Version When the Run Mode Program Version is Version 1.2.3 and the Safe Mode Program Version is Version 1.2.2

Command Area

Memory offset	Data name	bit15-12	bit11-8	bit7-4	bit3-0
+1	CmdCode	2	0	0	1
+2	CmdParam1	0	0	0	0
+3	CmdParam2	0	0	0	0



Response Area

Memory offset	Data name	bit15-12	bit11-8	bit7-4	bit3-0	
+1	ErrCode	0	0	0	0	
+2	RespInfo1	0	0	0	0	
+3	RespInfo2	0	0	0	0	
+4	RespData[0-1]	0	0	0	1	} Run Mode program version information
+5	RespData[2-3]	0	0	0	2	
+6	RespData[4-5]	0	0	0	3	
+7	RespData[6-7]	0	0	0	1	} Safe Mode program version information
+8	RespData[8-9]	0	0	0	2	
+9	RespData[10-11]	0	0	0	2	

GET OPERATING TIME

This command reads the operating time since the Reader/Writer was started.
The operating time is reset when the Reader/Writer is reset.

Command Area

Signal/data	Data type	Size	Function
CmdCode/Command Code	WORD	2 bytes	2002 hex
CmdParam1/Command Parameter 1	WORD	2 bytes	0000 hex (Not used.)
CmdParam2/Command Parameter 2	WORD	2 bytes	0000 hex (Not used.)

Response Area

Signal/data	Data type	Size	Function
ErrCode/Error code	WORD	2 bytes	Error code
ResplInfo1/Response Information 1	WORD	2 bytes	0000 hex (Not used.)
ResplInfo2/Response Information 2	WORD	2 bytes	0000 hex (Not used.)
RespData/Response Data			
Operating time	UDINT	4 bytes	Running time since the Reader/Writer was started (in milliseconds) 0000 0000 to FFFF FFFF hex

Execution Example

Reading the Operating Time When It Is 1,234,567,890 (4996 02D2 hex)

Command Area

Memory offset	Data name	bit15-12	bit11-8	bit7-4	bit3-0
+1	CmdCode	2	0	0	2
+2	CmdParam1	0	0	0	0
+3	CmdParam2	0	0	0	0



Response Area

Memory offset	Data name	bit15-12	bit11-8	bit7-4	bit3-0
+1	ErrCode	0	0	0	0
+2	ResplInfo1	0	0	0	0
+3	ResplInfo2	0	0	0	0
+4	RespData[0-1]	0	2	D	2
+5	RespData[2-3]	4	9	9	6

MEASURE NOISE

This command measures the noise level around the Reader/Writer.

Command Area

Signal/data	Data type	Size	Function
CmdCode/Command Code	WORD	2 bytes	2003 hex
CmdParam1/Command Parameter 1	WORD	2 bytes	0000 hex (Not used.)
CmdParam2/Command Parameter 2	WORD	2 bytes	0000 hex (Not used.)

Response Area

Signal/data	Data type	Size	Function
ErrCode/Error code	WORD	2 bytes	Error code
RespInfo1/Response Information 1	WORD	2 bytes	0000 hex (Not used.)
RespInfo2/Response Information 2	WORD	2 bytes	0000 hex (Not used.)
RespData/Response Data			
Average Noise Level	UINT	2 bytes	0000 to 0063 hex (level 0 to 99)
Maximum Noise Level	UINT	2 bytes	0000 to 0063 hex (level 0 to 99)
Minimum Noise Level	UINT	2 bytes	0000 to 0063 hex (level 0 to 99)

Execution Example

Measuring the Noise Level When the Average Level Is 51 (0033 Hex), the Maximum Level Is 62 (003E ex), and the Minimum Level Is 41 (0029 Hex)

Command Area

Memory offset	Data name	bit15-12	bit11-8	bit7-4	bit3-0
+1	CmdCode	2	0	0	3
+2	CmdParam1	0	0	0	0
+3	CmdParam2	0	0	0	0



Response Area

Memory offset	Data name	bit15-12	bit11-8	bit7-4	bit3-0
+1	ErrCode	0	0	0	0
+2	RespInfo1	0	0	0	0
+3	RespInfo2	0	0	0	0
+4	RespData[0-1]	0	0	3	3
+5	RespData[2-3]	0	0	3	E
+6	RespData[4-5]	0	0	2	9

GET COMMAND ERROR LOG

This command reads the log of command errors that have occurred in the Reader/Writer. The command error log is reset when the Reader/Writer is restarted.

Command Area

Signal/data	Data type	Size	Description
CmdCode/Command Code	WORD	2 bytes	2004 hex
CmdParam1/Command Parameter 1	WORD	2 bytes	Number of first record to read 0000 to 000F hex (0 to 15)
CmdParam2/Command Parameter 2	WORD	2 bytes	Number of records to read 0001 to 0010 hex (1 to 16) * The maximum number of records that you can specify depends on the tag data link settings.

Response Area

Signal/data	Data type	Size	Description	
ErrCode/Error Code	WORD	2 bytes	Error code	
RespInfo1/Response Information 1	WORD	2 bytes	0000 hex (Not used.)	
RespInfo2/Response Information 2	WORD	2 bytes	0000 hex (Not used.)	
RespData/Response Data				
Number of Records		UINT	2 bytes	Number of valid records in the command error log 0000 to 0010 hex (1 to 16)
Newest Record	Operating Time	UDINT	4 bytes	Operating time when the error occurred (unit: ms) 0000 0000 to FFFF FFFF hex
	IP Address of the Remote Device	DWORD	4 bytes	IP address of host device that generated the error 0000 0000 to FFFF FFFF hex Example: C0A801C8 (192.168.1.200)
	Command Code	WORD	2 bytes	Command code for which an error occurred
	Error Code	WORD	2 bytes	Error code of the error that occurred
	Response Information 1	WORD	2 bytes	Response information 1 for the error that occurred
	Response Information 2	WORD	2 bytes	Response information 2 for the error that occurred
Newest Record - 1	Same as above.	Same as above.	Same as above.	Same as above.
:	:	:	:	:
Newest Record - 15	Same as above.	Same as above.	Same as above.	Same as above.

* The maximum size of the response data depends on the tag and tag set settings. Therefore, the number of command error log records that can be read with one operation will vary. A parameter error will occur if the setting exceeds the response data size.

Execution Example

Reading the Two Newest Records from the Command Error Log When Command Errors Occur

* This example assumes that there are the following two valid records in the command error log.

"Error code 2001 hex occurred for command code 0001 hex at the host device (IP address 192.168.1.10) at an operating time of 11,223,344 (00AB 4130 hex).

"Error code 2002 hex occurred for command code 0002 hex at the host device (IP address 192.168.1.10) at an operating time of 11,223,345 (00AB 4131 hex).

Command Area

Memory offset	Data name	bit15-12	bit11-8	bit7-4	bit3-0
+1	CmdCode	2	0	0	4
+2	CmdParam1	0	0	0	0
+3	CmdParam2	0	0	0	2



Response Area

Memory offset	Data name	bit15-12	bit11-8	bit7-4	bit3-0	
+1	ErrCode	0	0	0	0	
+2	RespInfo1	0	0	0	0	
+3	RespInfo2	0	0	0	0	
+4	RespData[0-1]	0	0	0	2	} Number of records
+5	RespData[2-3]	4	1	3	1	
+6	RespData[4-5]	0	0	4	B	} Operating time
+7	RespData[6-7]	0	1	0	A	
+8	RespData[8-9]	C	0	A	8	} IP address
+9	RespData[10-11]	0	0	0	2	
+10	RespData[12-13]	2	0	0	2	} Command code
+11	RespData[14-15]	0	0	0	0	
+12	RespData[16-17]	0	0	0	0	} Error code
+13	RespData[18-19]	4	1	3	0	
+14	RespData[20-21]	0	0	4	B	} Response information 1
+15	RespData[22-23]	0	1	0	A	
+16	RespData[24-25]	C	0	A	8	} Response Information 2
+17	RespData[26-27]	0	0	0	1	
+18	RespData[28-29]	2	0	0	1	} Operating time
+19	RespData[30-31]	0	0	0	0	
+20	RespData[32-33]	0	0	0	0	} IP address
⋮	⋮	⋮	⋮	⋮	⋮	
⋮	⋮	⋮	⋮	⋮	⋮	} Command code
+125	RespData[242-243]	0	0	0	0	
+126	RespData[244-245]	0	0	0	0	} Error code
+127	RespData[246-247]	0	0	0	0	
+128	RespData[248-249]	0	0	0	0	} Response information 1
+129	RespData[250-251]	0	0	0	0	
+130	RespData[252-253]	0	0	0	0	} Response Information 2
+131	RespData[254-255]	0	0	0	0	
+132	RespData[256-257]	0	0	0	0	

Newest record in the command error log

Newest record - 1 in the command error log

Newest record - 15 in the command error log

GET RESTORE INFORMATION

This command reads the restore information from memory in the Reader/Writer.
The restore information is reset when the Reader/Writer is reset.

Command Area

Signal/data	Data type	Size	Function
CmdCode/Command Code	WORD	2 bytes	2005 hex
CmdParam1/Command Parameter 1	WORD	2 bytes	Number of first record to read 0000 to 0007 hex (0 to 7)
CmdParam2/Command Parameter 2	WORD	2 bytes	Number of records to read 0001 to 008 hex (1 to 8) * The maximum number of records that you can specify depends on the tag data link settings.

Response Area

Signal/data	Data type	Size	Function	
ErrCode/Error Code	WORD	2 bytes	Error code	
RespInfo1/Response Information 1	WORD	2 bytes	0000 hex (Not used.)	
RespInfo2/Response Information 2	WORD	2 bytes	0000 hex (Not used.)	
RespData/Response Data				
Number of Records		UINT	2 bytes	Number of valid records in the restore information 0000 to 0008 hex (1 to 8)
Newest Record	Operating Time	UDINT	4 bytes	Operating time in milliseconds when RF Tag data lost error occurred 0000 0000 to FFFF FFFF hex
	RF Tag ID	ARRAY[] OF BYTE	8 bytes	UID of the RF Tag when the RF Tag data lost error occurred
	User Address	WORD	2 bytes	First write address when an RF Tag data lost error occurred
	Data Size	WORD	2 bytes	Write size when an RF Tag data lost error occurred
	Data	BYTE[] OF BYTE	8 bytes	Data in the RF Tag before the write operation when the RF Tag data lost error occurred
Newest Record - 1	Same as above.	Same as above.	Same as above.	Same as above.
;	:	:	:	:
Newest Record - 7	Same as above.	Same as above.	Same as above.	Same as above.

* The maximum size of the response data depends on the tag and tag set settings. Therefore, the number of records of restore information that can be read with one operation will vary. A parameter error will occur if the setting exceeds the response data size.

▪ Execution Example

Reading the Newest Restore Information Record When Writing to an RF Tag Fails and an RF Tag Data Lost Error Occurs

* This example assumes that there is the following one valid record of restore information.

" Operating time: 1,234,567,890 (4996 02D2 hex)

" RF Tag ID: 6655 4433 2211 05E0

" User address: 1234 hex

" Data size: 0004 hex

" Data: 1122 3344 5566 7788 hex

Command Area

Memory offset	Data name	bit15-12	bit11-8	bit7-4	bit3-0
+1	CmdCode	2	0	0	5
+2	CmdParam1	0	0	0	0
+3	CmdParam2	0	0	0	1



Response Area

Memory offset	Data name	bit15-12	bit11-8	bit7-4	bit3-0	
+1	ErrCode	0	0	0	0	
+2	RespInfo1	0	0	0	0	
+3	RespInfo2	0	0	0	0	
+4	RespData[0-1]	0	0	0	1	} Number of records
+5	RespData[2-3]	0	2	D	2	
+6	RespData[4-5]	4	9	9	6	} Operating time
+7	RespData[6-7]	5	5	6	6	
+8	RespData[8-9]	3	3	4	4	} RF Tag UID
+9	RespData[10-11]	1	1	2	2	
+10	RespData[12-13]	E	0	0	5	} User address
+11	RespData[14-15]	1	2	3	4	
+12	RespData[16-17]	0	0	0	4	} Data size
+13	RespData[18-19]	2	2	1	1	
+14	RespData[20-21]	4	4	3	3	} Data
+15	RespData[22-23]	6	6	5	5	
+16	RespData[24-25]	8	8	7	7	
⋮	⋮	⋮	⋮	⋮	⋮	
+128	RespData[248-249]	0	0	0	0	} Operating time
+129	RespData[250-251]	0	0	0	0	
+130	RespData[252-253]	0	0	0	0	} RF Tag UID
+131	RespData[254-255]	0	0	0	0	
+132	RespData[256-257]	0	0	0	0	} User address
+133	RespData[258-259]	0	0	0	0	
+134	RespData[260-261]	0	0	0	0	} Data size
+135	RespData[262-263]	0	0	0	0	
+136	RespData[264-265]	0	0	0	0	} Data
+137	RespData[266-267]	0	0	0	0	
+138	RespData[268-269]	0	0	0	0	
+139	RespData[270-271]	0	0	0	0	

Newest record in restore information

Newest record – 7 in restore information

GET MULTI-READER/WRITER STATUS

This command reads the Master Reader/Writer and Slave Reader/Writer status when multi-Reader/Writer operation is being used.

Command Area

Signal/data	Data type	Size	Description
CmdCode/Command Code	WORD	2 bytes	2006 hex
CmdParam1/Command Parameter 1	WORD	2 bytes	0000 hex (Not used.)
CmdParam2/Command Parameter 2	WORD	2 bytes	0000 hex (Not used.)

Response Area

Signal/data	Data type	Size	Description
ErrCode/Error Code	WORD	2 bytes	Error code
RespInfo1/Response Information 1	WORD	2 bytes	0000 hex (Not used.)
RespInfo2/Response Information 2	WORD	2 bytes	0000 hex (Not used.)
RespData/Response Data			
Master Status	WORD	2 bytes	Multi-Reader/Writer status of Master Reader/Writer 0000 hex: Disable 1000 hex: Preparing for Field Extension Mode (Detecting Groups) 1001 hex: Ready for Field Extension Mode (Group Detection Completed) 2000 hex: Preparing for High-speed Traveling Mode (Detecting Groups) 2001 hex: Ready for High-speed Traveling Mode (Group Detection Completed)
Slave No. 1 Status	WORD	2 bytes	Connection status of Slave Reader/Writers No. 1 to 7 0000 hex: Not connected.
:	:	:	0001 hex: Connection successful
Slave No. 7 Status	WORD	2 bytes	0002 hex: Connection failed

Execution Example

Reading the Multi-Reader/Writer Status When the Reader/Writer Is in Field Extension Mode, the Group Is Being Detected, Connection of Slave Reader/Writer No. 2 Failed, and Slave Reader/Writers No. 3 to 7 Are Not Connected

Command Area

Memory offset	Data name	bit15-12	bit11-8	bit7-4	bit3-0
+1	CmdCode	2	0	0	6
+2	CmdParam1	0	0	0	0
+3	CmdParam2	0	0	0	0



Response Area

Memory offset	Data name	bit15-12	bit11-8	bit7-4	bit3-0	
+1	ErrCode	0	0	0	0	
+2	RespInfo1	0	0	0	0	
+3	RespInfo2	0	0	0	0	
+4	RespData[0-1]	1	0	0	0	} Master Reader/Writer
+5	RespData[2-3]	0	0	0	1	} Slave Reader/Writer No. 1
+6	RespData[4-5]	0	0	0	2	} Slave Reader/Writer No. 2
+7	RespData[6-7]	0	0	0	0	} Slave Reader/Writer No. 3
+8	RespData[8-9]	0	0	0	0	} Slave Reader/Writer No. 4
+9	RespData[10-11]	0	0	0	0	} Slave Reader/Writer No. 5
+10	RespData[12-13]	0	0	0	0	} Slave Reader/Writer No. 6
+11	RespData[14-15]	0	0	0	0	} Slave Reader/Writer No. 7

RESET

This command resets the Reader/Writer.

Command Area

Signal/data	Data type	Size	Function
CmdCode/Command Code	WORD	2 bytes	3000 hex
CmdParam1/Command Parameter 1	WORD	2 bytes	0000 hex (Not used.)
CmdParam2/Command Parameter 2	WORD	2 bytes	0000 hex (Not used.)

Response Area

Signal/data	Data type	Size	Function
ErrCode/Error Code	WORD	2 bytes	Error code
RespInfo1/Response Information 1	WORD	2 bytes	0000 hex (Not used.)
RespInfo2/Response Information 2	WORD	2 bytes	0000 hex (Not used.)

Execution Example

Resetting the Reader/Writer

Command Area

Memory offset	Data name	bit15-12	bit11-8	bit7-4	bit3-0
+1	CmdCode	3	0	0	0
+2	CmdParam1	0	0	0	0
+3	CmdParam2	0	0	0	0



Response Area

Memory offset	Data name	bit15-12	bit11-8	bit7-4	bit3-0
+1	ErrCode	0	0	0	0
+2	RespInfo1	0	0	0	0
+3	RespInfo2	0	0	0	0

Time Charts

Time Charts

■ Executing RF Tag Communications Commands

▪ Using the Once Communications Option

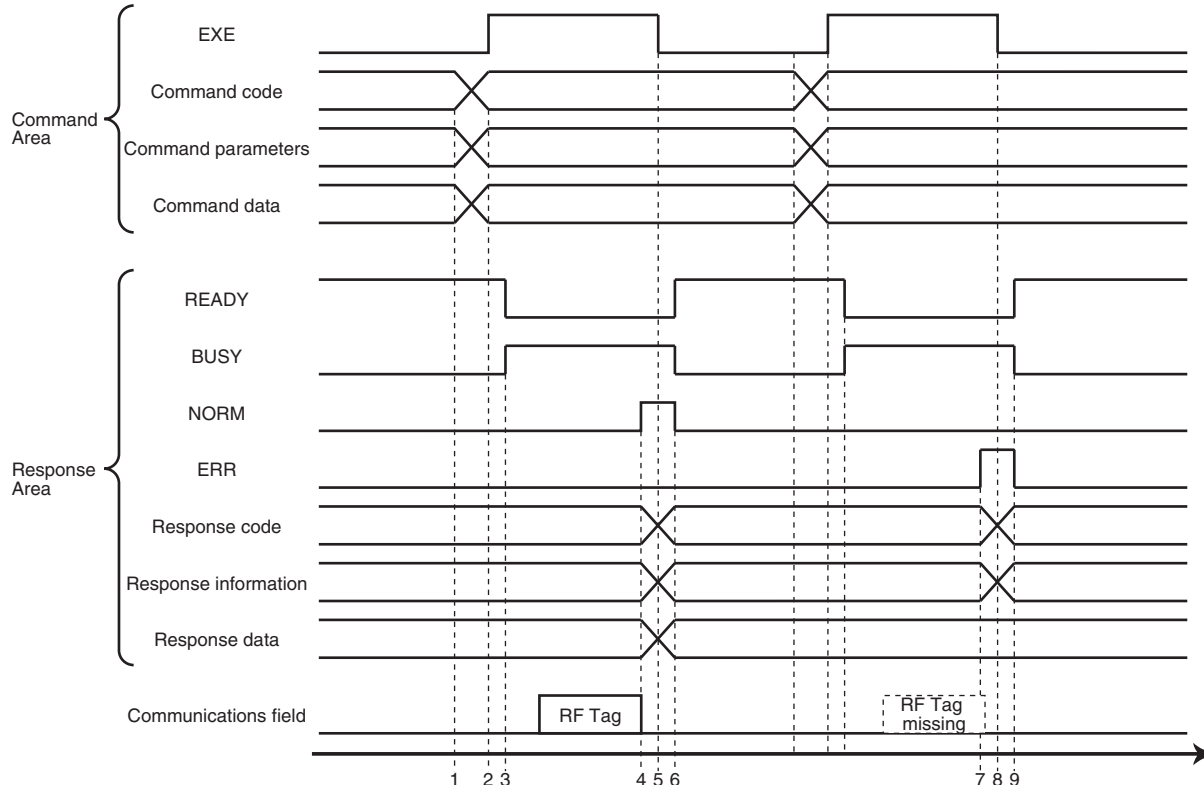

1. The command code, command parameters, and command data are set from the PLC while the READY signal is ON.
2. The user (PLC) turns ON the EXE signal. This tells the Reader/Writer to start execution.
3. When the Reader/Writer receives the instruction to start execution, it turns OFF the READY signal and turns ON the BUSY signal.
4. The Reader/Writer detects an RF Tag and when communications end normally, it sets the response code, response information, and response data and turns ON the NORM signal.
5. The user (PLC) detects that the NORM signal has turned ON and reads the response data. After reading the data, the user (PLC) turns OFF the EXE signal. This tells the Reader/Writer to stop execution.
6. When the Reader/Writer receives the instruction to stop execution, it turns ON the READY signal and turns OFF the BUSY signal and the NORM signal.
7. When command execution ends in an error (e.g., the Reader/Writer does not detect an RF Tag or communications fail), it sets the response code and response information and turns ON the ERR signal.
8. The user (PLC) detects that the ERR signal has turned ON, reads the response code and response information, and checks the error. After checking the error, the user (PLC) turns OFF the EXE signal. This tells the Reader/Writer to stop execution.
9. When the Reader/Writer receives the instruction to stop execution, it turns ON the READY signal and turns OFF the BUSY signal and the ERR signal.

▪ Using the Auto Communications Option

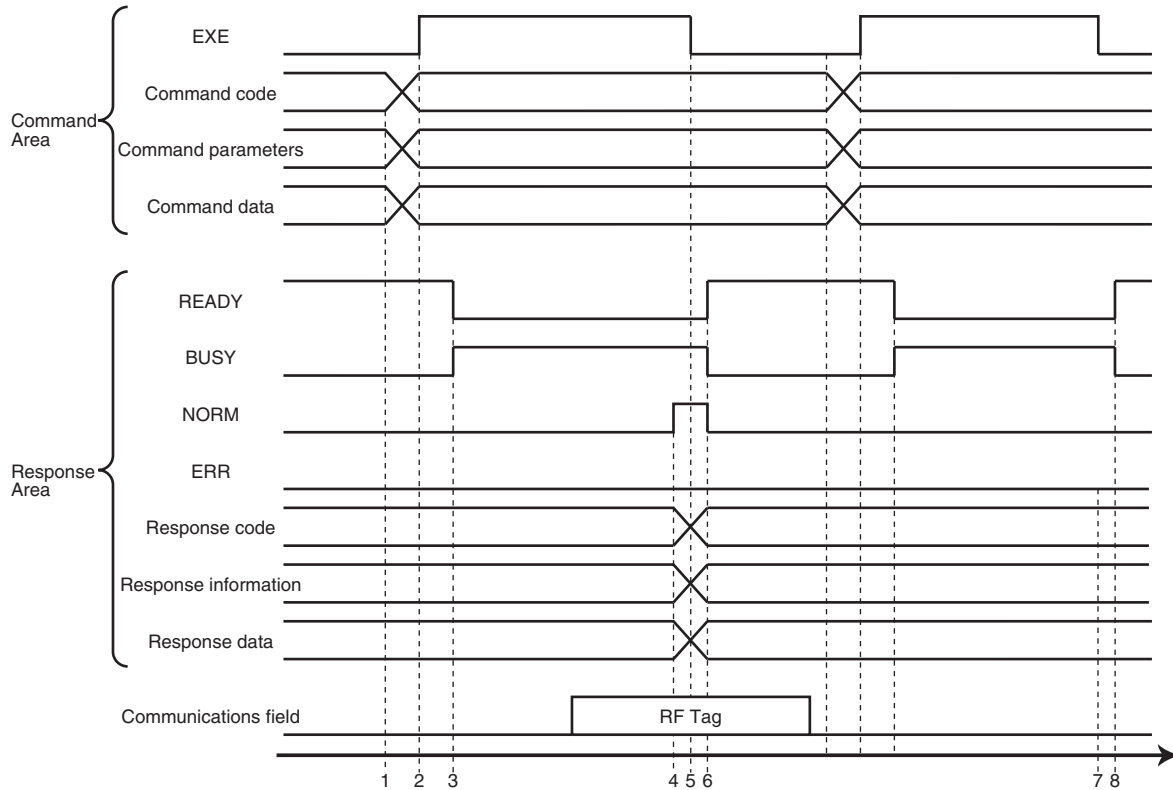

1. The command code, command parameters, and command data are set from the PLC while the READY signal is ON.
2. The user (PLC) turns ON the EXE signal. This tells the Reader/Writer to start execution.
3. When the Reader/Writer receives the instruction to start execution, it turns OFF the READY signal and turns ON the BUSY signal. From this timing, the reader / writer keeps waiting for the RF tag to enter the communication area.
4. The Reader/Writer detects an RF Tag and when communications end normally, it sets the response code, response information, and response data and turns ON the NORM signal. At this time, the NORM LED (green) lights up once.
5. The user (PLC) detects that the NORM signal has turned ON and reads the response data. After reading the data, the user (PLC) turns OFF the EXE signal. This tells the Reader/Writer to stop execution.
6. When the Reader/Writer receives the instruction to stop execution, it turns ON the READY signal and turns OFF the BUSY signal and the NORM signal.
7. If the BUSY signal is ON and the user (PLC) wants to cancel Auto communications, the user (PLC) turns OFF the EXE signal. This tells the Reader/Writer to stop execution.
8. When the Reader/Writer receives the instruction to stop execution, it turns ON the READY signal and turns OFF the BUSY signal and the ERR signal.

▪ Using the Repeat or FIFO Repeat Communications Option

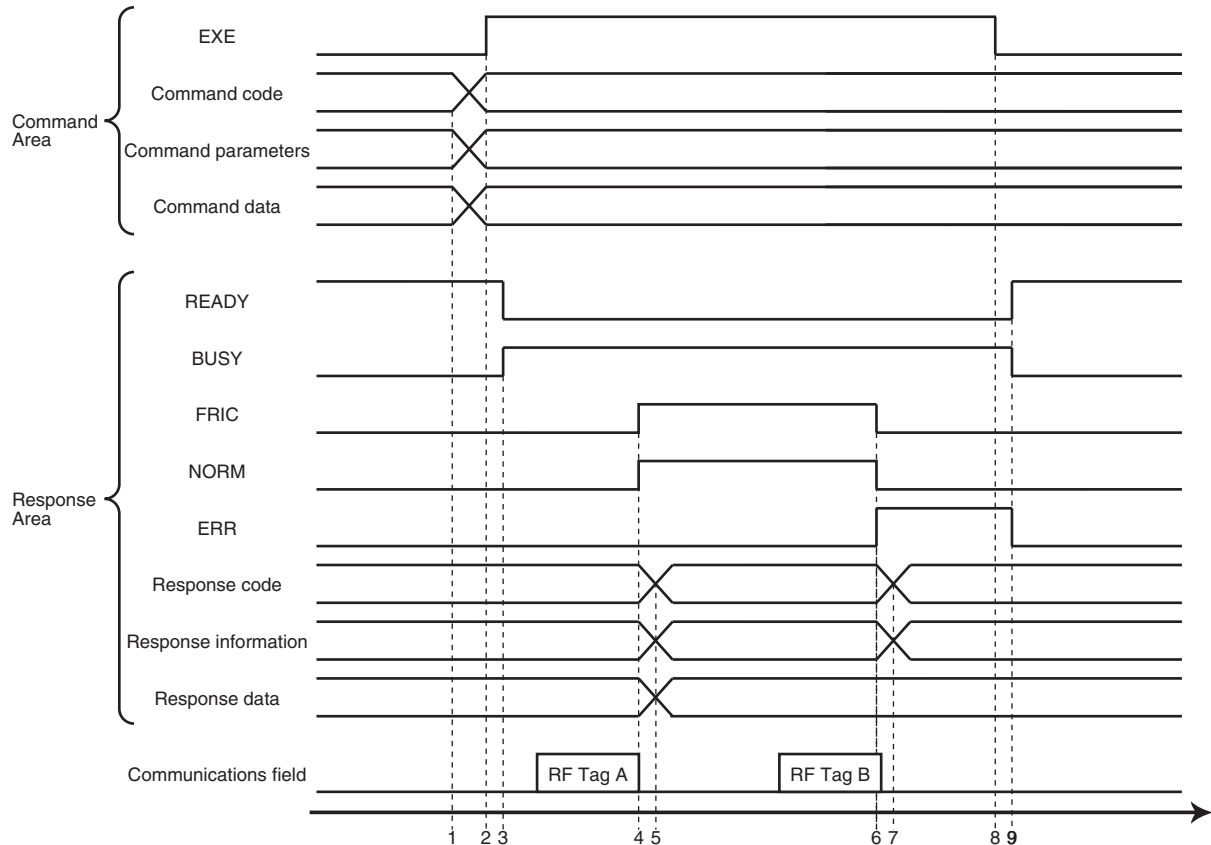

1. The command code, command parameters, and command data are set from the PLC while the READY signal is ON.
2. The user (PLC) turns ON the EXE signal. This tells the Reader/Writer to start execution.
3. When the Reader/Writer receives the instruction to start execution, it turns OFF the READY signal and turns ON the BUSY signal.
4. The Reader/Writer detects the first RF Tag (RF Tag A) and when communications end normally, it sets the response code, response information, and response data, toggles the FRIC signal (turns it ON), and turns ON the NORM signal.
5. The user (PLC) detects that the FRIC signal has changed and that the NORM signal has turned ON and reads the response data.
6. The Reader/Writer detects the second RF Tag (RF Tag B) and when communications end in an error, it sets the response code and response information, toggles the FRIC signal (turns it OFF), and turns ON the ERR signal.
7. The user (PLC) detects that the FRIC signal has changed and that the ERR signal has turned ON, reads the response code and response information, and checks the error.
8. If the BUSY signal is ON and the user (PLC) wants to cancel Repeat or FIFO Repeat communications, the user (PLC) turns OFF the EXE signal. This tells the Reader/Writer to stop execution.
9. When the Reader/Writer receives the instruction to stop execution, it turns ON the READY signal and turns OFF the BUSY, FRIC, NORM, and ERROR signals.

■ Executing Other Commands

■ Executing Reader/Writer Setting, Reader/Writer Information Acquisition, or Reader/Writer Operation Control Commands

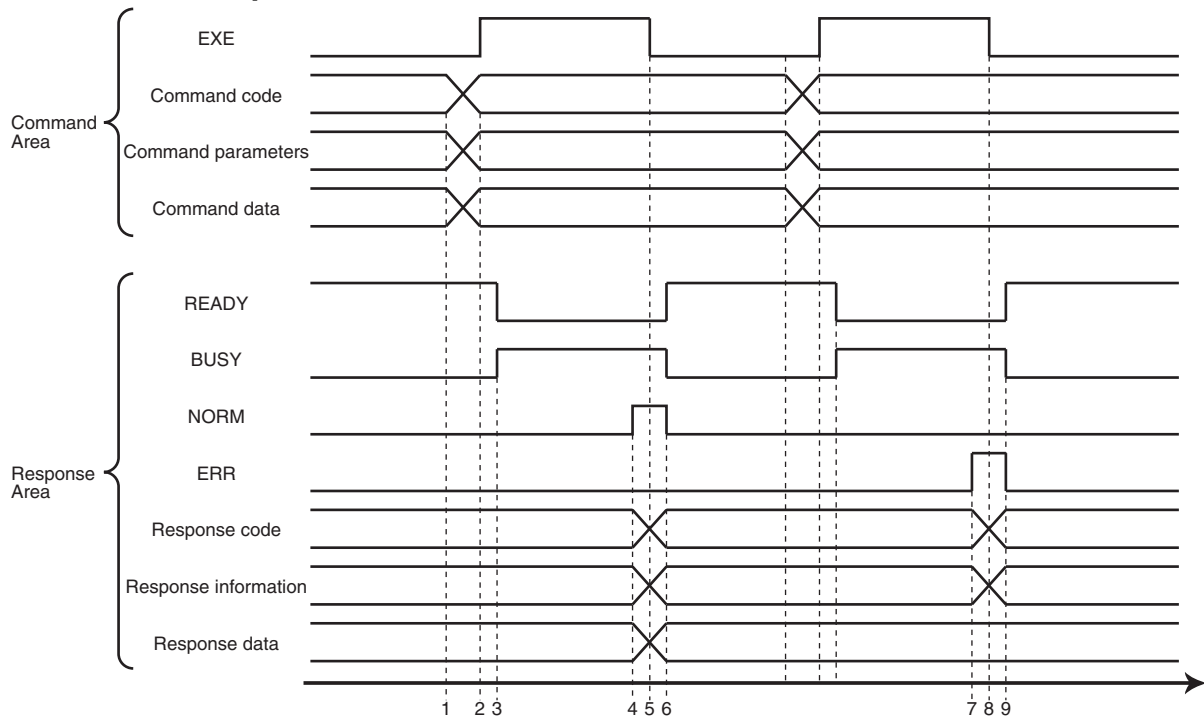

1. The command code, command parameters, and command data are set from the PLC while the READY signal is ON.
2. The user (PLC) turns ON the EXE signal. This tells the Reader/Writer to start execution.
3. When the Reader/Writer receives the instruction to start execution, it turns OFF the READY signal and turns ON the BUSY signal.
4. When communications end normally, the Reader/Writer sets the response code and response data and turns ON the NORM signal.
5. The user (PLC) detects that the NORM signal has turned ON and reads the response data. After reading the data, the user (PLC) turns OFF the EXE signal. This tells the Reader/Writer to stop execution.
6. When the Reader/Writer receives the instruction to stop execution, it turns ON the READY signal and turns OFF the BUSY signal and the ERR signal.
7. When communications end in an error, the Reader/Writer sets the response code and response information and turns ON the ERR signal.
8. The user (PLC) detects that the ERR signal has turned ON, reads the response code and response information. After reading the data, the user (PLC) turns OFF the EXE signal. This tells the Reader/Writer to stop execution.
9. When the Reader/Writer receives the instruction to stop execution, it turns ON the READY signal and turns OFF the BUSY signal and the ERR signal.

▪ **Executing the RESET Command**

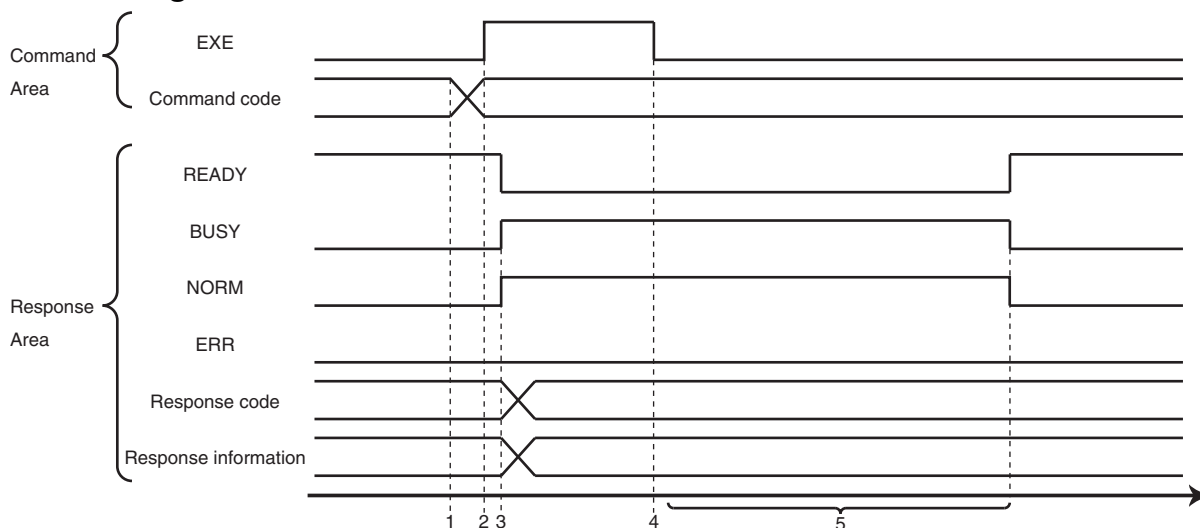

1. Set the command code of the RESET command in the PLC while the READY signal is ON.
2. The user (PLC) turns ON the EXE signal. This tells the Reader/Writer to start execution.
3. When the Reader/Writer receives the instruction to start execution, it turns OFF the READY signal and turns ON the BUSY signal. If the Reader/Writer can be reset, it sets the response code and turns ON the NORM signal.
4. When the PLC detects that the NORM signal is ON, it turns OFF the EXE signal. This tells the Reader/Writer to stop execution.
5. When the Reader/Writer receives the instruction to stop execution, it resets itself. After the Reader/Writer restarts and the tag data link connections are established again, the Reader/Writer turns ON the READY signal and turns OFF the BUSY signal and NORM signal.

Section 8

Browser Interface

❖ Browser Operation Window	188
❖ Operation Interface	190
Password Entry View	190
Status View	191
Network Settings View	192
Communications Settings View	193
SET MULTI-READER/WRITER OPERATION	194
RF Tag Communications View	195
Log View	196
Noise Monitor View	197
RF Analyzer	202
Reboot	202
Configuration	203
Configuration File	208

Browser Operation Window

Connect the Ethernet cable and start a Web browser on the computer.

Enter the IP address of the Reader/Writer in the address field of the Web browser to display the browser operation window.

Enter http://192.168.1.200 if you are using the default IP address.

If a Web password is not set in the Reader/Writer, the Status View will be displayed first.

To display another view, click the specified menu button.

Only one browser can connect to the Reader/Writer at one time. If another browser B connects to the Reader/Writer while browser A is displaying the Reader/Writer interface, browser A will be cut off and the Reader/Writer will communicate with browser B.

The WEB browser interface can be used in the following operating environments.

- Windows 7, Windows 8.1, or Windows 10 with Internet Explorer 8 or higher
- The combination of the firmware version and the JRE version

Reader/Writers firmware version	JRE version	Java 6	Java 7	Java 8		
				Up to Update73	Update74 to Update201	Update211 or later *1
Ver1.01		Available	Available	Not available	Not available	Not available
Ver2.00		Available	Available	Not available	Not available	Not available
Ver3.00		Not available	Available	Available	Not available *2	Not available *2
Ver3.01/Ver.3.02		Not available	Available	Available	Available	Available

*1: Commercial license is required for Java 8 Update 211 (April 16, 2019).

*2: Java 8 Update74 (February 5, 2016) or later can not be connected.



There is a case where WEB browser can not be used in a combination of the firmware version of Reader/Writer and the JRE version.

Refer to the table above, please use JRE version that was appropriate for your Reader/Writer.

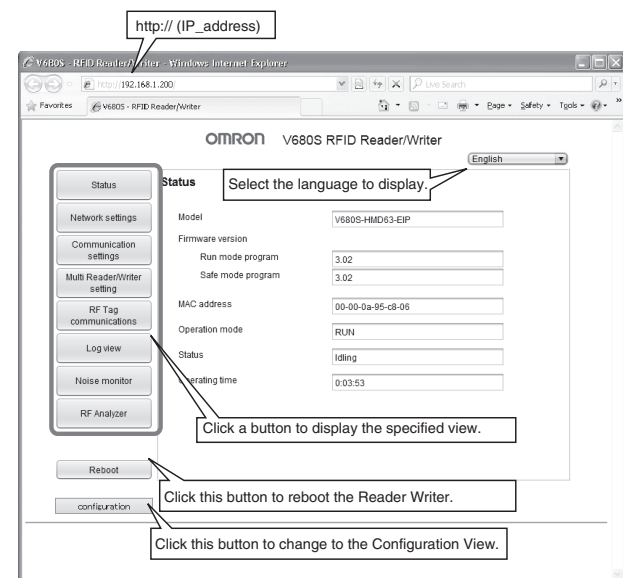

* Windows is a registered trademark of Microsoft Corporation in the USA and other countries.

Screen shots are used with permission from Microsoft.

* Java software can be downloaded from the following.

URL: <https://www.oracle.com/technetwork/java/archive-139210.html>

(*URL is as of April 2019 and may change in the future.)

- Java and other trademarks that contain “Java” are the registered trademarks of Oracle Corporation or its related companies.



CHECK!

The screen layout may be broken if you configure display magnification to other than 100%.



CHECK!

The operating indicator (Green) may flash because the web browser communicates with the Reader/Writer at fixed interval.

Operation Interface

Password Entry View

If a Web password is set in the Reader/Writer, the Password Entry View will be displayed first.

OMRON V680S RFID Reader/Writer



Password :

OK

Item name	Description
Password	If a Web password is set in the Reader/Writer, enter the password.



If an error message appears after pressing the **OK** button, confirm the password.



If the Reader/Writer is running in Safe mode, the password entry screen does not appear even if you set the password.

Status View

OMRON V680S RFID Reader/Writer English ▾

Status

Network settings

Communication settings

Multi Reader/Writer setting

RF Tag communications

Log view

Noise monitor

RF Analyzer

Reboot

configuration

Status

Model

Firmware version

Run mode program

Safe mode program

MAC address

Operation mode

Status

Operating time

Item name		Description
Device type		Displays the product model number.
Firmware version	Run mode program	Displays the Run Mode program versions. Displays only "Major version" and "Minor version".
	Safe mode program	Displays the Safe Mode program versions. Displays only "Major version" and "Minor version".
MAC address		Displays the MAC address from the Reader/Writer.
Operation mode		Displays the mode of the Reader/Writer. Run/Safe Mode
Status		Displays the status of the Reader/Writer. Idling/RF Tag communications in progress and Changing settings/Error
Operating time		Displays the time since the Reader/Writer was started. Example: 0:12:34

Network Settings View

OMRON V680S RFID Reader/Writer English ▾

Status

Network settings

Communication settings

Multi Reader/Writer setting

RF Tag communications

Log view

Noise monitor

RF Analyzer

Reboot

configuration

Network settings

Fixed setting

IP address

Subnet mask

Gateway address

Obtain from BOOTP server

Fix at the IP address which is obtained from BOOTP server

Web port

Web password

Device name

Click this button to set the displayed values.

Item name	Description	Setting range	Default
IP address	IP address	---	192.168.1.200
Subnet mask	Subnet mask address	---	255.255.255.0
Gateway address	Gateway address	---	192.168.1.254
BOOTP Options	Fixed setting, Obtain from BOOTP server, or Fix at the IP address which is obtained from BOOTP server	---	Fixed setting
Web Port	The port number used for browser communications	1024 to 65535	7090
Web password	15 ASCII characters max.	15 ASCII characters max.	None
Device name	63 ASCII characters max.	63 ASCII characters max.	None



If you change the network settings, restart the Reader/Writer. The new settings will be effective after a restart of the Reader/Writer.



When you restart the Reader/Writer after you change the IP address, WEB browser can not reconnect to the Reader/Writer. If you re-specified the new IP address in the address field of the browser, the screen will be appeared.



The error message is displayed if you change the configuration during the Reader/Writer is executing RF tag communication or Noise measurement.

Communications Settings View

OMRON V680S RFID Reader/Writer

English

Status

Network settings

Communication settings

Multi Reader/Writer setting

RF Tag communications

Log view

Noise monitor

RF Analyzer

Reboot

configuration

RF Tag communication settings

RF Tag communications option

RF Tag communications condition

RF Tag communications speed

Write verify

RF Communication Diagnostics Enable Disable

Click this button to set the displayed values.

Item name	Description	Setting range	Default
RF Tag Communications option	Select the RF Tag communications option.	Once, Auto, Repeat, FIFO Repeat (Without ID code check) or FIFO Repeat (With ID code check)	Once
RF Tag Communications Speed	Specify the speed of communications with the RF Tags.	High speed or Normal speed	High speed
Write Verify	Select this check box to enable write verification.	Enabled/disabled	Enabled
Use diagnostics	Select to enabled or disabled.	Enabled/disabled	Enabled

Refer to *Communications Options* in *Section 6 Functions* for information of RF Tag Communications option.

 p.93

Refer to *Setting Communications Conditions* in *Section 6 Functions* for information of RF Tag Communications option.

 p.103

 The settings are immediately reflected when you click the "Set" button.

CHECK!

 When the Reader/Writer is running in safe mode, this screen can not be operated. Run the Reader/Writer in RUN mode.

CHECK!

Refer to *RFID System Maintenance* in *Section 6 Functions* for communication diagnostic.

 p.108

 The error message is displayed if you change the configuration during the Reader/Writer is executing RF tag communication or Noise measurement.

CHECK!

SET MULTI-READER/WRITER OPERATION

OMRON V680S RFID Reader/Writer

English

Status

Network settings

Communication settings

Multi Reader/Writer setting

RF Tag communications

Log view

Noise monitor

RF Analyzer

Reboot

configuration

Multi Reader/Writer setting

Multi Reader/Writer mode Disable Field extension mode High-speed travelling mode

Group setting	IP address	Status
Slave Reader/Writer No.1	<input type="text"/>	<div style="width: 10px; height: 10px; background-color: gray;"></div>
Slave Reader/Writer No.2	<input type="text"/>	<div style="width: 10px; height: 10px; background-color: gray;"></div>
Slave Reader/Writer No.3	<input type="text"/>	<div style="width: 10px; height: 10px; background-color: gray;"></div>
Slave Reader/Writer No.4	<input type="text"/>	<div style="width: 10px; height: 10px; background-color: gray;"></div>
Slave Reader/Writer No.5	<input type="text"/>	<div style="width: 10px; height: 10px; background-color: gray;"></div>
Slave Reader/Writer No.6	<input type="text"/>	<div style="width: 10px; height: 10px; background-color: gray;"></div>
Slave Reader/Writer No.7	<input type="text"/>	<div style="width: 10px; height: 10px; background-color: gray;"></div>

Click this button to set the displayed values.

Item name	Description	Setting range	Default setting
Multi Reader/Writer mode	Sets the Multi-Reader/Writer Mode.	Disable, Field extension mode, or High-speed traveling mode	Disable
Group setting	You can check the IP address of Reader/Writers registered as Slave Reader/Writers and the connection status of all of the Slave Reader/Writers.	-	-
IP address	You can set or check the IP addresses of Slave Reader/Writers No. 1 to 7.	-	-
Status	You can check the connection status of Slave Reader/Writers No. 1 to 7 with the displayed colors.	Not registered: Gray Connection failed: Red Connection successful: Green	-



If you change any of the multi-Reader/Writer settings, restart the Reader/Writer. The new settings will be enabled after the Reader/Writer is restarted.

CHECK!



You can register IP addresses for up to seven Slave Reader/Writers on this view. If you set the Multi-Reader/Writer Mode to anything other than Disable and set the IP address for a Slave Reader/Writer, the Slave Reader/Writer will become a Master Reader/Writer.

CHECK!



There can be only one Master Reader/Writer in any one group.

CHECK!

RF Tag Communications View

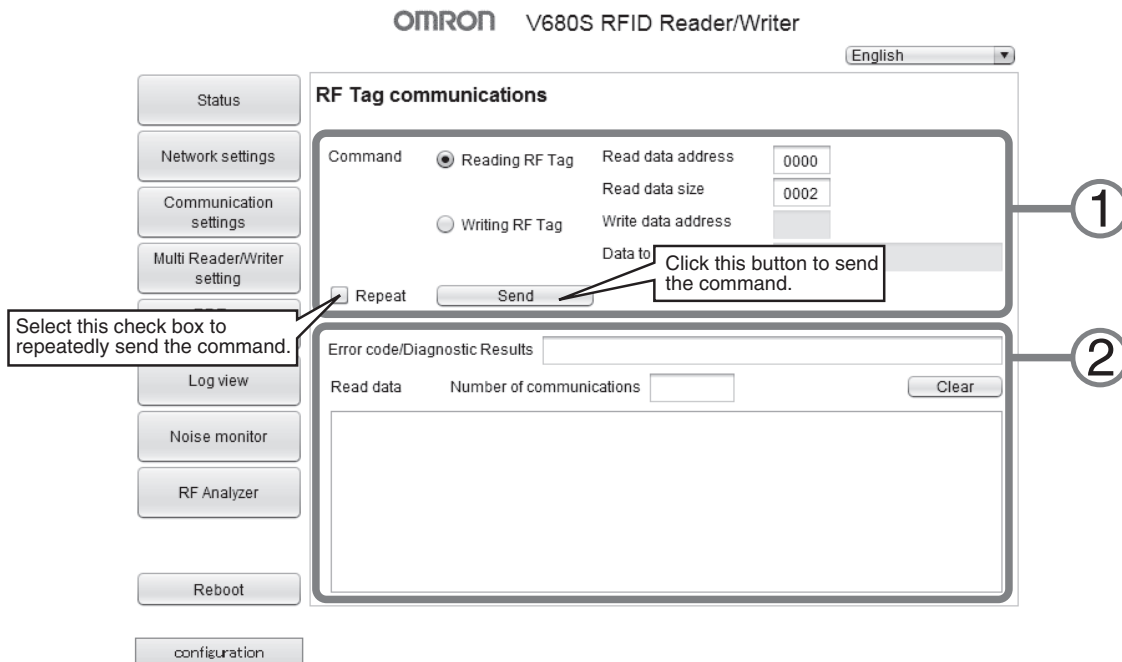

1. Command Area

Item name		Description	Setting range
Reading RF Tag	Read data address	Specify in 4-digit hexadecimal the first address to read from the RF Tag.	0000 to 0999 hex
	Read data size	Specify in 4-digit hexadecimal the number of words of data to read from the RF Tag.	0001 to 007D hex
Writing RF Tag	Write data address	Specify in 4-digit hexadecimal the first address to write in the RF Tag.	0000 to 0999 hex
	Data to write	Specify the data to write to RF Tag.	1 to 113 words
Repeat		Select this check box to repeatedly and consecutively send the command. Clear the selection of this check box if the RF Tag communications option of the Reader/Writer is set to Repeat or FIFO Repeat. If a command is sent repeatedly and consecutively with the Repeat or FIFO Repeat option, an execution status error will occur.	

2. Response Area

Item name	Description
Error code/Diagnostics results	The background will be green when the response returned by the Reader/Writer indicates a normal end. If the response indicates an error end, the background will be red and the error code will be displayed. If communications diagnostics are enabled and communications with the RF Tag are determined to be unstable, the background will be yellow and the diagnostics result is displayed.
Number of communications	The total number of commands that have been sent to the Reader/Writer is displayed.
Read data	The data that was read in communications with the RF Tag is displayed.
Clear	This button clears the number of sent commands and read data.

Refer to *RFID System Maintenance* in *Section 6 Functions* for details on communications diagnostics.

p.108



If RF Tag communications are attempted when the Reader/Writer is performing RF Tag communications, noise measurement, or other processing, an error will occur. Perform operations when the Reader/Writer is not busy with another operation.

Log View

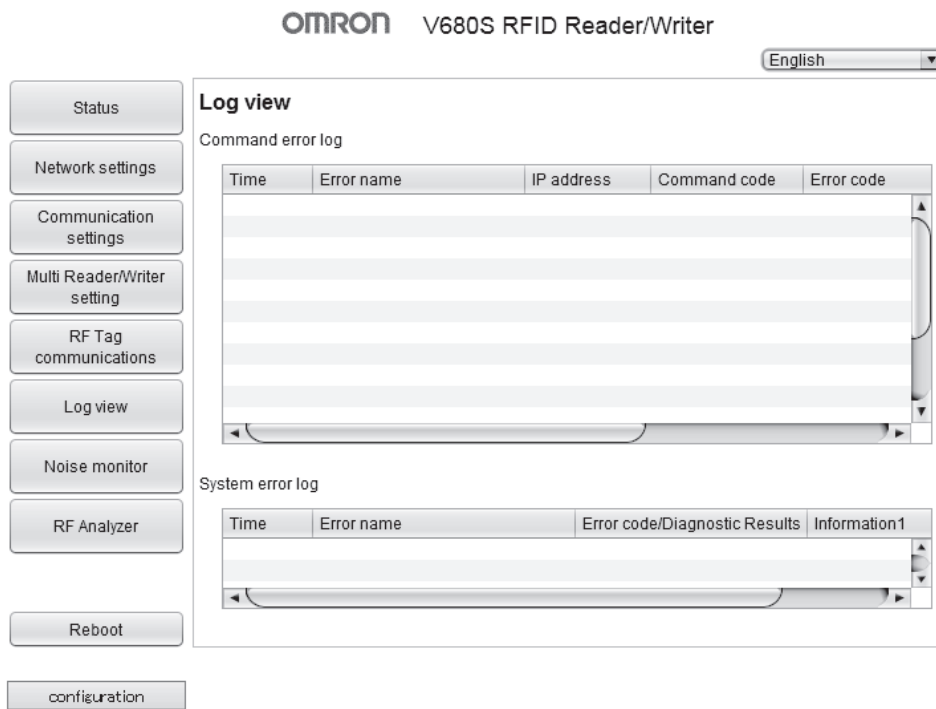

Item name	Description
Command error log	Displays the following command error log information. Operating time, error name, IP address, command code, error code, attached information 1, and attached information 2
System error log	Displays the following information from the system error log: Operating time, error name, error code, attached information 1, and attached information 2

Refer to *Command Error Log* in *Section 6 Functions* for details on the command error log.

 p.107

Refer to *System Error Log* in *Section 6 Functions* for details on the system error log.

 p.106

Noise Monitor View

You can check the graphed noise level (one second intervals) around the Reader/Writer.

Select from the screen, the type of the RF tag you want to use, because the communication performance will be changed by the combination of the type of the RF tag to be used.

The “Normal area”, “Precaution area” and “Warning area” will be appeared on the screen according to the type of the RF tag to be used.

Normal area	Means the noise level that communications range can be reduced to about less than 20%
Precaution area	Means the noise level that communications range can be reduced to about 20% to 50%.
Warning area	Means the noise level that communications range can be reduced to about 50% or more.



When the Reader/Writer is running in safe mode, this screen can not be operated. Run the Reader/Writer in RUN mode.

CHECK!

About the relationship between the Reader/Writer communication performance and the noise level, refer to *Noise Measurement* in *Section 6 Functions*.



p.101



Because there is variation in the result of the noise measurement, consider the result as a guideline.

CHECK!

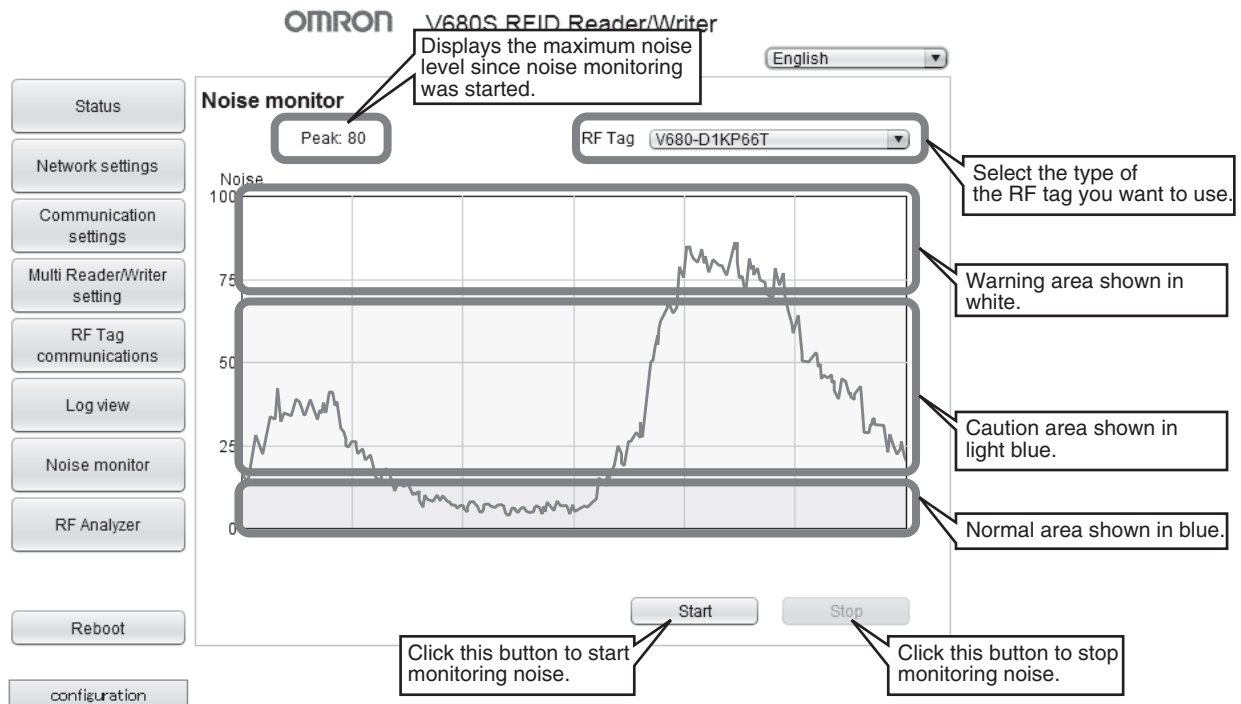

Item name	Description
Noise monitor	The display is updated every second. The maximum, average, and minimum noise levels since noise monitoring was started are displayed.



The error message is displayed if you change the configuration during the Reader/Writer is executing RF tag communication or Noise measurement.

CHECK!

RF Analyzer

You can use the RF Analyzer to check the diagnostic information from communication diagnostic. You can easily see whether communications are stable, unstable, or in error when communication diagnostic is used.

If communications are unstable, you can display probable causes and display guidance that provides detailed cause confirmation and corrections.

If an error occurs, the error name and corrections are displayed.

The RF Analyzer is updated every 5 seconds while it is displayed.



When the Reader/Writer is running in safe mode, this screen can not be operated. Run the Reader/Writer in RUN mode.

CHECK!



The diagnostic log is not displayed while communication diagnostic is disabled. Enable communication diagnostic on the Communications Setting View.

CHECK!



If the number of records in the diagnostic log exceeds 2,048, the oldest records are overwritten.

CHECK!

The screenshot shows the 'RF Analyzer' interface. At the top, it displays 'Total : 128 Warning : 20 Error : 6'. Below this is a table with columns: No, Time, Command, Result, Diagnostic description, and Details. The table contains 7 rows of data. Callouts point to various elements: 'Total number of records in diagnostic log (2,048 max.), Number of unstable communications, Number of errors' points to the summary bar; 'English' and 'Export' buttons are at the top right; 'You can save the diagnostic log in a CSV file on the computer.' points to the 'Export' button; 'This button is displayed when diagnostic results show unstable communications. Click the button to display guidance in a separate window so that you can check probable causes and corrections.' points to a 'Display' button in the details column; 'You can check the diagnostic log on a graph.' points to the 'Graph' button; and 'Click this button to clear the diagnostic log.' points to the 'Clear the Log' button. A sidebar on the left contains navigation buttons like 'Status', 'Network settings', 'Communication settings', etc.

Item name	Description
No.	Numbers are assigned from 1 to 2,048. The larger the number, the more recent the information.
Time	The Reader/Writer operating time when the diagnostic information was registered.
Command	The command that was executed when the diagnostics information was registered.
Result	One of the following: Stable, Unstable, or Error
Diagnostic description	The probable cause and corrections are displayed for unstable communications and communications errors.
Details	A button is displayed for unstable communications. Click the button and follow the displayed guidance to display probable causes and corrections.

■ RF Analyzer Guidance

Click the **Display** Button in the *Details* column on the RF Analyzer View to display guidance. Respond yes or no to the displayed questions to display advice on the probable causes and corrections.

If you follow the advice to make corrections, you can increase the communications leeway and achieve more stable RFID System operation.

The Signal Level is low.

Follow the instruction in below.

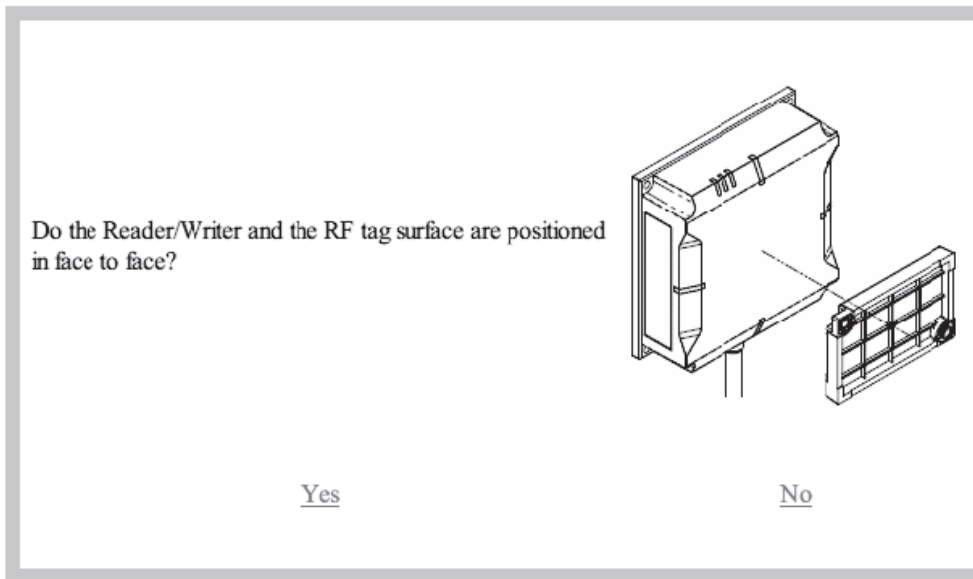

RF Analyzer Graphs

You can display time-based graphs of diagnostic log information.

This allows you to visually understand the data from communication diagnostic and quantitatively confirm the degree of leeway in communications.

Two parameters are displayed for the graph.

1. Power Level

To communicate with RF Tags, the power levels of the Reader/Writer and RF Tags must be sufficiently high. You can display the power levels in 10 levels from 0 to 10 on a bar graph. The higher the value, the more leeway there is in communications. If there is sufficient communications leeway, the level is 10. If a communication fails (i.e., if an error occurs), the level will be 0 and no bar will be displayed. A value of 1 to 9 means that the communications leeway is low (i.e., that communications are unstable), and the bar will be displayed in yellow. In this case, we recommend that you follow the guidance described above and adjust the installation conditions to increase the communications leeway as close as possible to a level of 10.

2. Noise Level

The ambient noise level around the Reader/Writer during communications with the RF Tag is displayed in red on a broken-line graph. The lower the noise level, the better the conditions. A noise level of 5 or higher means that the communications leeway is low (i.e., that communications are unstable), and the bar will be displayed in yellow.

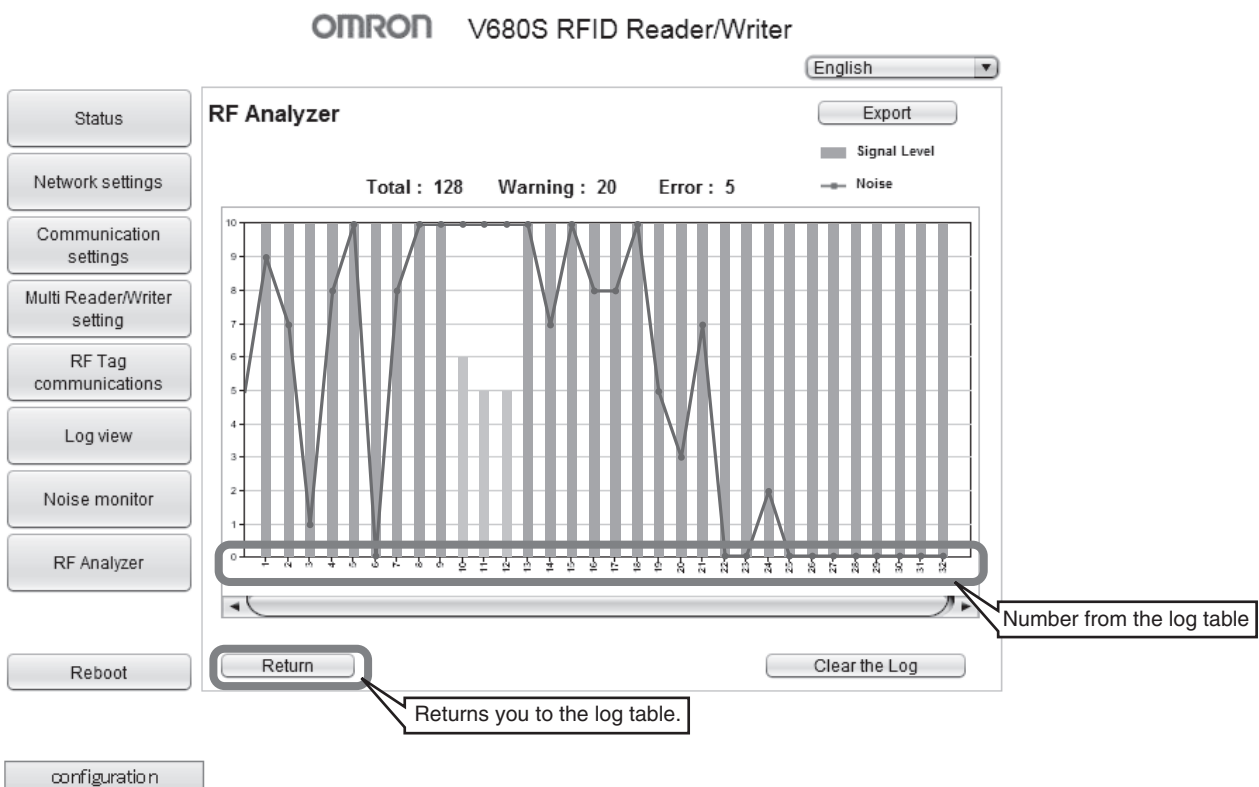

■ RF Analyzer Diagnostic Log File

You can click the **Export** Button on the RF Analyzer View to download the diagnostic log stored in the Reader/Writer to a computer and save it as a CSV file. The following information is included in the diagnostic log file. You can use it to check more detailed information than you can on the web browser displays.

Item name	Description
No	Numbers are assigned from 1 to 2,048. The larger the number, the more recent the information.
Time Stamp	The Reader/Writer operating time when the diagnostic information was registered.
Command	The command type that was executed when the diagnostic information was registered.
Response Result	The communications result is displayed. "Warning" is displayed if the communications diagnostic result shows an unstable communication. <ul style="list-style-type: none"> • Normal: Normal • Warning: Unstable • Other: Error type name
Diagnostic Result	The communications diagnostic result is displayed. <ul style="list-style-type: none"> • Good: Stable • Output level low: Low send power • Receiving level low: Low receive power • Noise level high: Excessive ambient noise level • Signal-Noise ratio low: Low signal-to-noise ratio • N/A: Communications error
Output Level	The send power level to the RF Tag is given between 0 and 10. The higher the value, the better the conditions. (If the level is 9 or lower, the Reader/Writer will determine that the communication was unstable.)
Receiving Level	The receive power level from the RF Tag to the Reader/Writer is given between 0 and 10. The higher the value, the better the conditions. (If the level is 9 or lower, the Reader/Writer will determine that the communication was unstable.)
Noise Level	The ambient noise level around the Reader/Writer is given between 0 and 10. The lower the value, the better the conditions. (If the level is 5 or higher, the Reader/Writer will determine that the communication was unstable.)
Signal Level	The overall level combining Output Level and Receiving Level is given between 0 and 10. The higher the value, the better the conditions.
Tag ID	The Tag ID of the RF Tag for which communication diagnostic was performed is given.

Reboot

If you click the **Reboot** Button on any of the operation views, a Confirm Reboot Dialog Box is displayed.

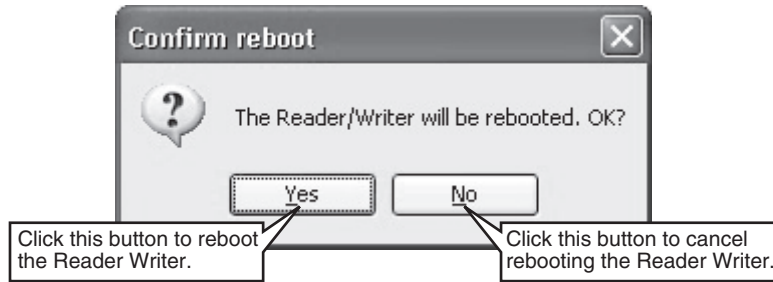

The following dialog box is displayed after the Reader/Writer has finished rebooting. Click the **Yes** Button to connect to the Reader/Writer.

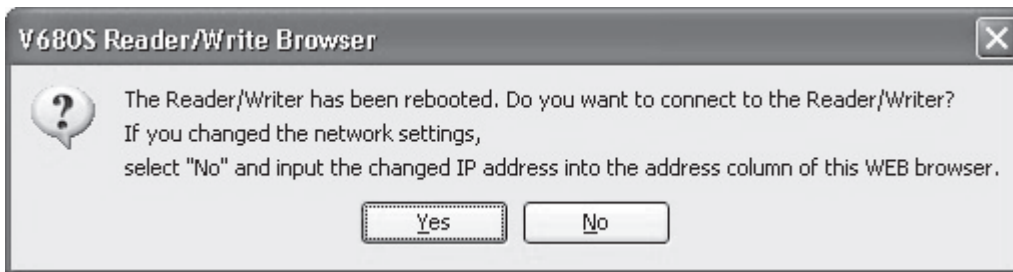

The following dialog box is displayed after reconnecting to the Reader/Writer. Click the **OK** Button.

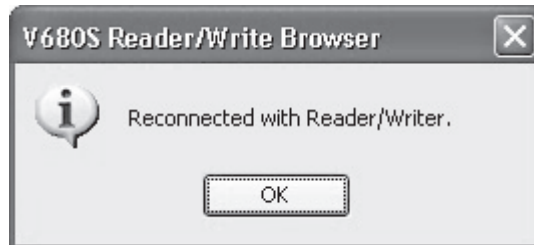

When re-connection goes wrong and an error message is displayed, Check the connection with the Reader/Writer and reboot a browser.

CHECK!

Configuration

You can save a configuration file (INI file) that contains the configuration information from the Reader/Writer in the computer. You can also send a configuration file to the Reader/Writer to change all of the configuration information in the Reader/Writer. Or, you can click the **Default** Button to return all of the configuration information in the Reader/Writer to the default settings.

To display the Configuration View, click the **Configuration** Button at the bottom of the browser operation window.

The screenshot shows the OMRON V680S RFID Reader/Writer browser interface. At the top, it says 'OMRON V680S RFID Reader/Writer' and 'English'. On the left is a vertical menu with buttons for: Status, Network settings, Communication settings, Multi Reader/Writer setting, RF Tag communications, Log view, Noise monitor, RF Analyzer, Reboot, and configuration. The 'configuration' button at the bottom is highlighted with a mouse cursor. The main area shows the 'Status' page with the following fields:

Model	V680S-HMD63-EIP
Firmware version	
Run mode program	3.02
Safe mode program	3.02
MAC address	00-00-0a-95-c8-06
Operation mode	RUN
Status	Idling
Operating time	0:03:53

Click the **Configuration** Button at the bottom of the browser operation window to display the Configuration View.

The screenshot shows the OMRON V680S RFID Reader/Writer browser interface displaying the Configuration View. It has three main sections:

- Export Configuration File to PC**: Contains an 'Export' button.
- Import Configuration File to R/W**: Contains a text input field, a 'Browse...' button, and an 'Import' button.
- Initialize Configuration**: Contains a 'Default' button.

At the bottom left, there is a 'Status' button.

Item name	Description
Export Configuration File to PC	Saves a configuration file that contains the Reader/Writer settings on the computer.
Import Configuration File to R/W	Updates the settings in the Reader/Writer with the settings in a configuration file that you select on the computer.
Initialize Configuration	Returns all of the settings in the Reader/Writer to the default settings.

■ Saving a Configuration File on the Computer

You can click the **Export** Button in the *Export Configuration File to PC* Area to save a configuration file (file name: conf.ini) that contains the configuration information from the Reader/Writer on the computer. The configuration file uses a normal INI file format.

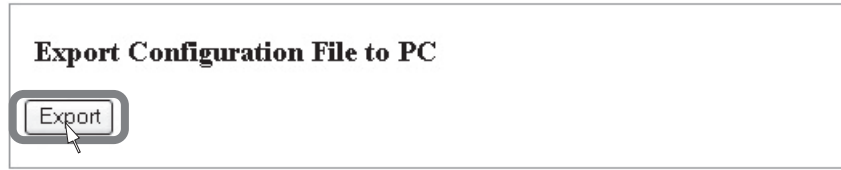

Click the **Export** Button. The following dialog box will be displayed. Click the **Save** Button.

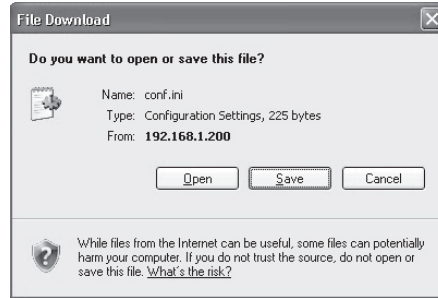

Specify where to save the file and click the **Save** Button. The configuration information from the Reader/Writer will be saved in the configuration file.

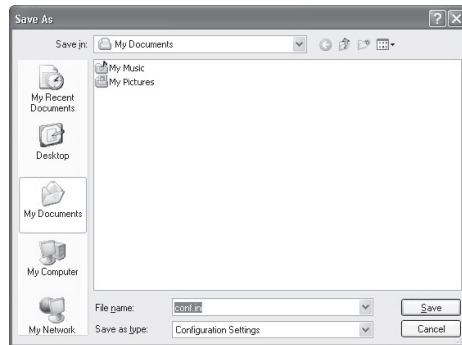

Example of a Configuration File

```
[NetworkSetting]
IPAddress=192.168.1.200
SubnetMask=255.255.255.0
GatewayAddress=192.168.1.254
BOOTPOption=0000
DeviceName=
WebPassword=
WebPortNo=7090
[RFTagCommunicationSetting]
CommunicationSpeed=0
WriteVerify=1
CommunicationOption=0
CommunicationDiagnostics=0
[MultiReaderWriterSetting]
MultiReaderWriterMode=0
SlaveNum=0
SlaveNo1IPAddress=0.0.0.0
SlaveNo2IPAddress=0.0.0.0
SlaveNo3IPAddress=0.0.0.0
SlaveNo4IPAddress=0.0.0.0
SlaveNo5IPAddress=0.0.0.0
SlaveNo6IPAddress=0.0.0.0
SlaveNo7IPAddress=0.0.0.0
```

■ Sending a Configuration File to the Reader/Writer

You can change all of the configuration information in the Reader/Writer with the following procedure: Click the **Browse** Button in the *Import Configuration File to R/W Area*, select the configuration file to use to set up the Reader/Writer, and then click the **Import** Button.

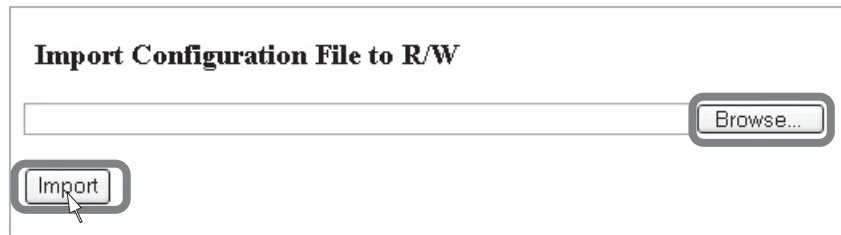

Click the **Browse** Button. A dialog box to select the configuration file will be displayed. Select the configuration file and then click the **Open** Button.

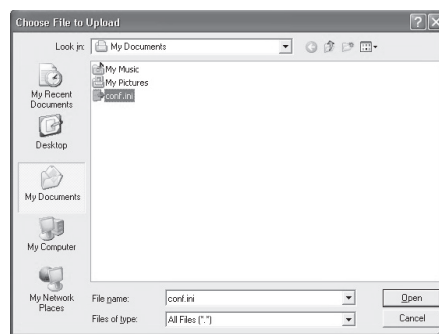

Click the **Import** Button. All of the configuration information in the Reader/Writer will be changed.

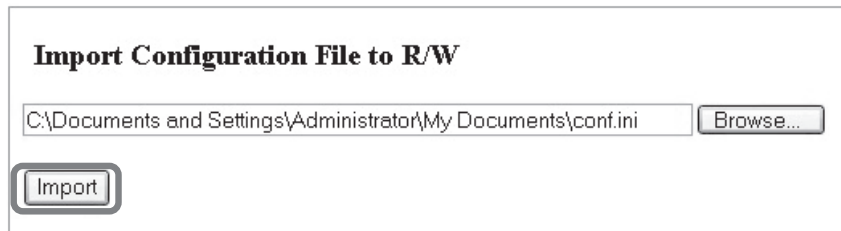

The following information is displayed after setting is completed.

```
[NetworkSetting]
  IPAddress = 192.168.1.200 Check OK
  SubnetMask = 255.255.255.0 Check OK
  GatewayAddress = 192.168.1.254 Check OK
  BOOTPOption = 0000 Check OK
  DeviceName = Check OK
  WebPassword = Check OK
  WebPortNo = 7090 Check OK
[RFTagCommunicationSetting]
  CommunicationSpeed = 0 Check OK
  WriteVerify = 1 Check OK
  CommunicationOption = 0 Check OK
  CommunicationDiagnostics = 0 Check OK
[MultiReaderWriterSetting]
  MultiReaderWriterMode = 0 Check OK
  SlaveNum = 0 Check OK
  SlaveNo1IPAddress = 0.0.0.0 Check OK
  SlaveNo2IPAddress = 0.0.0.0 Check OK
  SlaveNo3IPAddress = 0.0.0.0 Check OK
  SlaveNo4IPAddress = 0.0.0.0 Check OK
  SlaveNo5IPAddress = 0.0.0.0 Check OK
  SlaveNo6IPAddress = 0.0.0.0 Check OK
  SlaveNo7IPAddress = 0.0.0.0 Check OK
```

Configuration-Update Completed !!

■ Initializing the Settings

Click the **Default** Button in the *Initialize Configuration* Area to return all of the settings in the Reader/Writer to the default settings. After you initialize the settings, cycle the power supply to the Reader/Writer to enable the new settings.



Click the **Default** Button in the *Initialize Configuration* Area. The following dialog box will be displayed. Click the **OK** Button.

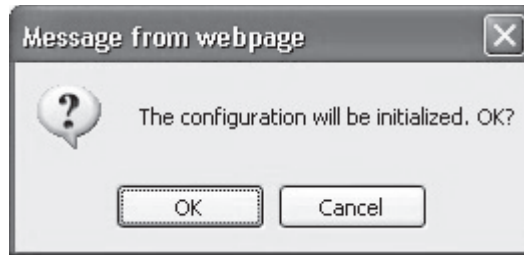

The following information is displayed after setting is completed. The network settings (NetworkSetting) are applied when the Reader/Writer is restarted. The RF Tag communications settings (RFTagCommunicationSetting) are applied immediately.

```

                [NetworkSetting]
                IPAddress = 192.168.1.200    Check OK
                SubnetMask = 255.255.255.0   Check OK
                GatewayAddress = 192.168.1.254 Check OK
                BOOTPOption = 0000           Check OK
                DeviceName =                  Check OK
                WebPassword =                 Check OK
                WebPortNo = 7090             Check OK
                [RFTagCommunicationSetting]
                CommunicationSpeed = 0        Check OK
                WriteVerify = 1              Check OK
                CommunicationOption = 0       Check OK
                CommunicationDiagnostics = 0  Check OK
                [MultiReaderWriterSetting]
                MultiReaderWriterMode = 0     Check OK
                SlaveNum = 0                 Check OK
                SlaveNo1IPAddress = 0.0.0.0  Check OK
                SlaveNo2IPAddress = 0.0.0.0  Check OK
                SlaveNo3IPAddress = 0.0.0.0  Check OK
                SlaveNo4IPAddress = 0.0.0.0  Check OK
                SlaveNo5IPAddress = 0.0.0.0  Check OK
                SlaveNo6IPAddress = 0.0.0.0  Check OK
                SlaveNo7IPAddress = 0.0.0.0  Check OK
    
```

Configuration-Update Completed !!

Configuration File

This section describes the format of the configuration file. The configuration file uses a normal INI file format.

- Any line that starts with a semicolon (;) is treated as a comment.
- Any line that starts with an opening bracket ([) is treated as a section declaration row. The row must also end in a closing bracket (]).
- Any row that does not start with either of the above two characters is an entry row.

■ Section and Entry Table

Section name	Entry name	Description	Default
NetworkSetting	IPAddress	Gives the setting of the IP address of the Reader/Writer. Specify four decimal numbers separated by periods.	192.168.1.200
	SubnetMask	Gives the setting of the subnet mask of the Reader/Writer. Specify four decimal numbers separated by periods.	255.255.255.0
	GatewayAddress	Gives the setting of the default gateway of the Reader/Writer. Specify four decimal numbers separated by periods.	192.168.1.254
	BOOTPOption	Gives the setting of the Reader/Writer BOOTP option. Specify a decimal value. 0: Fixed settings 1: Get from BOOTP server 2: Get from BOOTP server as fixed settings	0
	DeviceName	Gives the name of the Reader/Writer. Specify up to 63 ASCII characters.	
	WebPassword	Gives the login password for the browser interface. Specify up to 15 ASCII characters. Specify "" (blank) for no password.	
	WebPortNo	Gives the Ethernet communications port number for the browser interface. Specify 1024 to 65535 decimal.	7090
RFTagCommunicationSetting	CommunicationSpeed	Gives the communications speed between the Reader/Writer and RF Tags. Set a decimal number. 0: High speed 1: Normal speed	0
	WriteVerify	Gives the setting for write verification for write communications. Set a decimal number. 0: No verification 1: Verification	1
	CommunicationOption	Gives the setting of the RF Tag communications option. Set a decimal number. 0: Once 1: Repeat 2: FIFO Repeat (Without ID code check) 3: Auto 18: FIFO Repeat (With ID code check)	0

Section name	Entry name	Description	Default
MultiReaderWriterSetting	MultiReaderWriterMode	Gives the Reader/Writer Extended Mode settings. Specify a decimal value. 0: Disabled 1: Field Extension Mode 2: High-speed Traveling Mode	0
	SlaveNum	Gives the number of slaves in Field Extension Mode. Set a value between 0 and 7.	0
	SlaveNo1IPAddress	Give the IP Addresses in Reader/Writer Extended Mode. Specify four decimal numbers separated by periods.	0.0.0.0

SlaveNo7IPAddress			

MEMO

Section 9

Troubleshooting

❏ Error Descriptions	212
Fatal Errors	212
Nonfatal Errors	213
❏ Errors and Indicator Status	214
Fatal Errors	214
Nonfatal Errors	216
Tag Data Link Error	216
❏ Errors and Countermeasures	217
Reader/Writer Operation Errors	217
IP Address Duplication Error	218
System Errors	218
V680S Command Errors	220
RF Tag Communications Errors	221
❏ Troubleshooting Flowcharts	222
Main Check Flowchart	222
System Connections Check Flowchart	223
Operating Conditions and External Environment Check Flowchart	224
Host Device Communications Check Flowchart	225
RF Tag Communications Check Flow	226
❏ About The Ethernet Communication Abnormality	227
❏ Cannot Display the Web Browser Operation Window	228
Problem	228
Solution	229
Java installation	230
Java Security Settings	231
Java Security Settings Are Not Displayed	233
Register Trusted Site	234
Countermeasures for Other Problems	235
❏ Safe Mode	237
Starting in Safe Mode	237

Error Descriptions

Information on up to eight errors that occur are recorded until the power supply to the Reader/Writer is turned OFF. You can access this information from the host device or the Web server.

Fatal Errors

■ Reader/Writer Operation Errors

The NORM/ERR indicator in the operation indicators flashes red if the control signal is not stable or if an error occurs in user configuration memory. If the Reader/Writer detects a user configuration memory error during startup, it will start in Safe Mode and the RUN indicator will flash green.

Check the connection of the control signal or correct the user settings, and then cycle the power supply to the Reader/Writer to return to normal operation.

■ System Errors

The NORM/ERR indicator in the operation indicators lights red if there is a CPU error, system memory error, or hardware fault. If the Reader/Writer detects a system memory error during startup, it will start in Safe Mode and the RUN indicator will flash green.

■ IP Address Duplication Error

If an IP address duplication error is detected at startup, the NORM/ERR indicator in the operation indicators flashes red irregularly. Turn OFF the power supply to the Reader/Writer, remove the Reader/Writer from the network, correct the IP addresses, add the Reader/Writer to the network, and turn the power supply back ON.

■ BOOTP Server Connection Error

If an IP address cannot be obtained from the BOOTP server at startup, the NORM/ERR indicator in the operation indicators flashes irregularly. Correct the settings in the BOOTP server and cycle the power supply to the Reader/Writer.

Nonfatal Errors

The NORM/ERR indicator in the operation indicators flashes red once if an error occurs in communications between the Reader/Writer and host device or in communications with an RF Tag.

V680S-HMD63-EIP

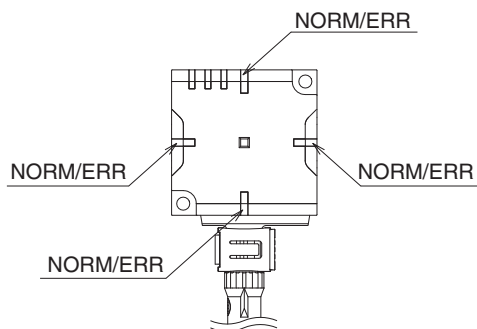

V680S-HMD64-EIP

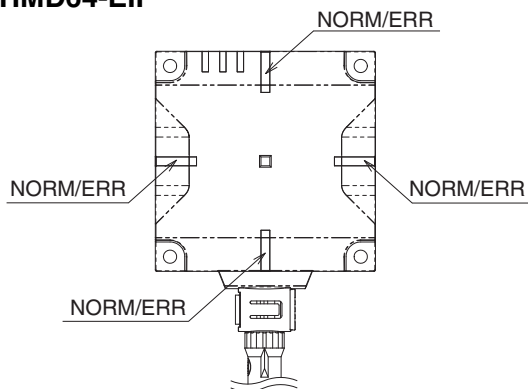

V680S-HMD66-EIP

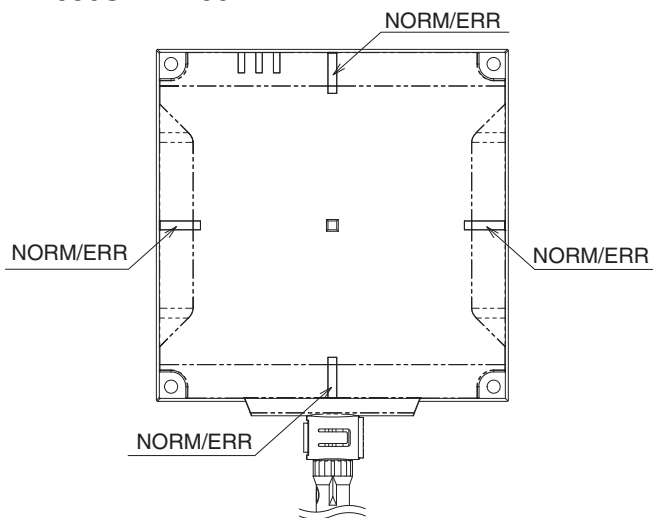



Errors and Indicator Status



Fatal Errors

Reader/Writer Operation Errors



User Configuration Memory Error

RUN	NORM/ERR	Processing when error occurs
		There is an error in user configuration memory. <ul style="list-style-type: none"> Initialize the settings to restore normal operation. Refer to <i>User Configuration Memory Error</i> in this Section for information for Initialize the setting.
Lit green or fast flashing green	Flashing red	 p.217



Unstable Control Signal or User Configuration Memory (Host Device Communications Conditions Settings) Error

RUN	NORM/ERR	Processing when error occurs
		The value of the control signal is not stable. <ul style="list-style-type: none"> See if the control signal line in the V680S Cable is connected correctly to 24 VDC. See if there is a source of strong noise near the Reader/Writer or Cable. There is an error in user configuration memory (host device communications conditions settings). <ul style="list-style-type: none"> Initialize the settings to restore normal operation. Refer to <i>User Configuration Memory Error</i> in this Section for information for Initialize the setting.
Flashing green	Flashing red	 p.217 * The Reader/Writer automatically starts in Safe Mode when it detects an error.

Multi-Reader/Writer Execution Error



RUN	NORM/ERR	Processing when error occurs
		The multi-Reader/Writer functions cannot be executed. <ul style="list-style-type: none"> Check the combination of the RF Tag communications option setting and multi-Reader/Writer function operating mode in the Master Reader/Writer. Correct the IP address settings so that the Slave Reader/Writer does not use the same IP address as the Master Reader/Writer. For details, refer <i>Section 6 Multi-Reader/Writer Operation</i> .
Flashing green or fast flashing green	Lit red	 p.113

IP Address Duplication Error (Indicator Flashes Red Irregularly)



RUN	NORM/ERR	Processing when error occurs
		Devices with the same IP address were detected during Reader/Writer startup. <ul style="list-style-type: none"> Correct the IP address settings of the Reader/Writers.
Fast flashing green	Flashing red irregularly	

■ **System Errors**

■ **CPU Error or Hardware Fault**



RUN	NORM/ERR	Processing when error occurs
		Take the appropriate action referring <i>System Errors</i> in this Section Replace the Reader/Writer if the condition does not change.  p.218
Lit green or fast flashing green	Lit red	

■ **System Memory Error**



RUN	NORM/ERR	Processing when error occurs
		Take the appropriate action referring <i>System Errors</i> in this Section Replace the Reader/Writer if the condition does not change.  p.218
Flashing green	Lit red	* If the Reader/Writer detects a fault, the Reader/Writer will start in the " Safe mode" automatically.

Nonfatal Errors

The NORM/ERR indicator flashes once if an error occurs in communications between the Reader/Writer and host device or in communications with an RF Tag.

RUN	NORM/ERR
	
Lit green or fast flashing green	Flashes red once

Tag Data Link Error

RUN	NORM/ERR
	
Lit green	Flashing yellow



CHECK!

If you use more than one Reader/Writer for multi-Reader/Writer operation, the ERROR indicator will light red once on any Reader/Writer for which an error is detected during communications with an RF Tag. The NORM indicator will light green once on any Reader/Writer that completes communications with an RF Tag normally. When the Master Reader/Writer returns a response to the host device, the NORM or ERROR indicator will light depending on whether the results given in the response is for a normal or error completion.

Errors and Countermeasures

Reader/Writer Operation Errors

■ User Configuration Memory Error

Initialize the settings to restore normal operation. There are the following two ways to initialize the Reader/Writer.

■ Initializing with a Command Message from the Host Device

You can send the INITIALIZE SETTINGS command to the Reader/Writer to return the settings to the default values.

■ Initializing through the Web Server

You can connect a computer to the network, start a Web browser, and return the settings to the default values from the Web browser window.

Refer to *Initializing the Settings in Configuration in Section 8 Browser Interface* for the procedure to Initializing through the Web Server.



■ Unfixed Operation Mode Error or User Configuration Memory (Host Device Communications Conditions Settings) Error

Identify the error on the Error Log View in the Web browser and restore operation with the countermeasure.

Refer to *Log View in Section 8 Browser Interface* for the procedure to check the error log contents from the Web browser window.



■ Unfixed Operation Mode Error

See if the control signal line is connected correctly to the 24 VDC terminal on the power source. Check for sources of noise around the Cable.

■ User Configuration Memory Error (Host Device Communications Conditions Settings)

Initialize the settings to restore normal operation. You can connect a computer to the network, start a Web browser, and return the settings to the default values from the Web browser window.

Refer to *Initializing the Settings in Configuration in Section 8 Browser Interface* for the procedure to Initializing through the Web Server.



■ Multi-Reader/Writer Execution Error

Check the combination of the Multi-Reader/Writer Mode and the communications option.

IP Address Duplication Error

Turn OFF the power supply to the Reader/Writer, remove the Reader/Writer from the network, correct the IP addresses, add the Reader/Writer to the network, and turn the power supply back ON.

System Errors

Turn OFF the power supply, check the wiring, and then turn ON the power supply. If the problem does not change, recovery is not possible for the error. Replace the Reader/Writer.

■ Multi-Reader/Writer Execution Error

Check the combination of the Multi-Reader/Writer Mode and the RF Tag communications option. Or, check the IP address settings to see if the Slave Reader/Writer is using the same IP address as the Master Reader/Writer.

The RF Tag communications commands that you can use during multi-Reader/Writer operation (Field Extension Mode or High-speed Traveling Mode) are shown in the following table.

If you use any RF Tag communications command that cannot be used for the Master Reader/Writer, an execution status error will be indicated in the response.

■ Commands That Can Be Addressed to a Master Reader/Writer

RF Tag communications command	Multi-Reader/Writer Mode	
	Field Extension Mode	High-speed Traveling Mode
READ DATA	Supported	Supported
WRITE DATA	Supported	Not supported
DATA FILL	Not supported	Not supported
RF TAG OVERWRITE COUNT CONTROL	Not supported	Not supported
READ ID	Supported	Not supported
COPY DATA	Not supported	Not supported
LOCK	Not supported	Not supported

■ **Commands That Can Be Acknowledged by a Slave Reader/Writer**

The following table shows the commands that a Reader/Writer that is operating as a slave can acknowledge.

If an unsupported command is received by a Slave Reader/Writer, an execution status error will be indicated in the response.

Command type	Name	Supported
RF Tag communications	READ DATA	No
	WRITE DATA	No
	READ ID	No
	COPY DATA	No
	DATA FILL	No
	LOCK	No
	RF TAG OVERWRITE COUNT CONTROL	No
	RESTORE DATA	No
Reader/Writer settings	SET TAG COMMUNICATIONS OPTION	No
	GET TAG COMMUNICATIONS OPTION	Yes
	SET TAG COMMUNICATIONS CONDITIONS	No
	GET TAG COMMUNICATIONS CONDITIONS	Yes
	SET TCP/IP COMMUNICATIONS CONDITIONS	No
	GET TCP/IP COMMUNICATIONS CONDITIONS	Yes
	SET DEVICE NAME	No
	GET DEVICE NAME	Yes
	SET TCP/IP COMMUNICATIONS CONDITIONS	No
	GET TCP/IP COMMUNICATIONS CONDITIONS	Yes
	SET WEB PASSWORD	No
	GET WEB PASSWORD	Yes
	INITIALIZE	No

Command type	Name	Supported
Checking Reader/Writer information	MEASURE NOISE	No
	GET MODEL INFORMATION	Yes
	GET FIRMWARE VERSION	Yes
	GET MAC ADDRESS	Yes
	GET READER/WRITER OPERATING STATUS	Yes
	GET OPERATING TIME	Yes
	GET RECENT ERROR COMMAND INFORMATION	Yes
	GET COMMUNICATIONS ERROR LOG	Yes
	GET SYSTEM ERROR LOG	Yes
	GET RESTORE INFORMATION	Yes
Reader/Writer operation control	STOP	No
	RESET	No
RFID maintenance	SET COMMUNICATIONS DIAGNOSTICS SETTINGS	No
	GET COMMUNICATIONS DIAGNOSTICS SETTINGS	Yes
Multi-Reader/Writer operation	SET MULTI-READER/WRITER OPERATION	No
	GET MULTI-READER/WRITER OPERATION SETTINGS	Yes
	GET MULTI-READER/WRITER OPERATION STATUS	Yes



You can use the maintenance functions with Reader/Writers with firmware version 3.00 or higher.



All linked Reader/Writers must have firmware version 3.00 or higher.

V680S Command Errors

You can check errors detected by the Reader/Writer in the Response Area where the Reader/Writer returns the response after command execution.





You can also check error information by sending the GET COMMAND ERROR LOG command to the Reader/Writer or by using the Error Log View on a browser. The following table provides detailed error information and countermeasures.

Error name	Error code	Countermeasure
Command parameter error	1005 hex	Check the contents of the command and send the correct contents. Make sure the command parameter values are correct.
Execution status error	1006 hex	Send the command again. Execution is not possible because the Reader/Writer is performing other processing.

RF Tag Communications Errors

You can check errors detected by the Reader/Writer in the Response Area where the Reader/Writer returns the response after command execution.

You can also check error information by sending the GET COMMAND ERROR LOG command to the Reader/Writer or by using the Error Log View on a browser. The following table provides detailed error information and countermeasures.

Error name	Error code	Countermeasure
RF Tag missing error	2001 hex	Change the control timing so that communications start when there is an RF Tag in the communications field of the Reader/Writer. Measure the noise and implement noise countermeasures.  p.101 Check the influence of surrounding metal and make sure there is sufficient communications range.
RF Tag communications error	2002 hex	Change the control timing so that communications start when there is an RF Tag in the communications field of the Reader/Writer. Measure the noise and implement noise countermeasures.  p.101 Check the influence of surrounding metal and make sure there is sufficient communications range.
UID mismatch error	2003 hex	Perform communications when the RF Tag for which data is to be restored is in the communications field of the Reader/Writer.
RF Tag address error	2004 hex	Adjust the processing area (addresses) for communications with the RF Tag to match the memory area of the RF Tag.
RF Tag lock error	2005 hex	The RF Tag memory region that contains the communications processing area (addresses) is locked. Check the communications processing area (addresses) and perform the process again or replace the RF Tag.
RF Tag verification error	2006 hex	Repeat the processing while the RF Tag is in the communications field of the Reader/Writer. Measure the noise and implement noise countermeasures.  p.101 Check the influence of surrounding metal and make sure there is sufficient communications range.
RF Tag data lost error	2007 hex	Repeat the processing while the RF Tag is in the communications field of the Reader/Writer. Measure the noise and implement noise countermeasures.  p.101 Check the influence of surrounding metal and make sure there is sufficient communications range.
RF Tag system error	2008 hex	Change to an RF Tag that is supported by the Reader/Writer.
RF Tag overwriting error	2009 hex	Replace the RF Tag.
Reader/Writer connection error	200A hex	Make sure that the copy destination Reader/Writer is operating normally. Make sure that the copy destination Reader/Writer is normally connected to the network and that there are no mistakes in the settings.
Communications connection error between Reader/Writers	200B hex	Make sure that the Slave Reader/Writers have started normally before you execute multi-Reader/Writer functions. Make sure that the Slave Reader/Writers are normally connected to the network and that there are no mistakes in the settings.

Troubleshooting Flowcharts

If an error occurs, fully check the whole situation, determine the relationship between the system and any other devices, and refer to the following flowcharts for the troubleshooting procedures.

Main Check Flowchart

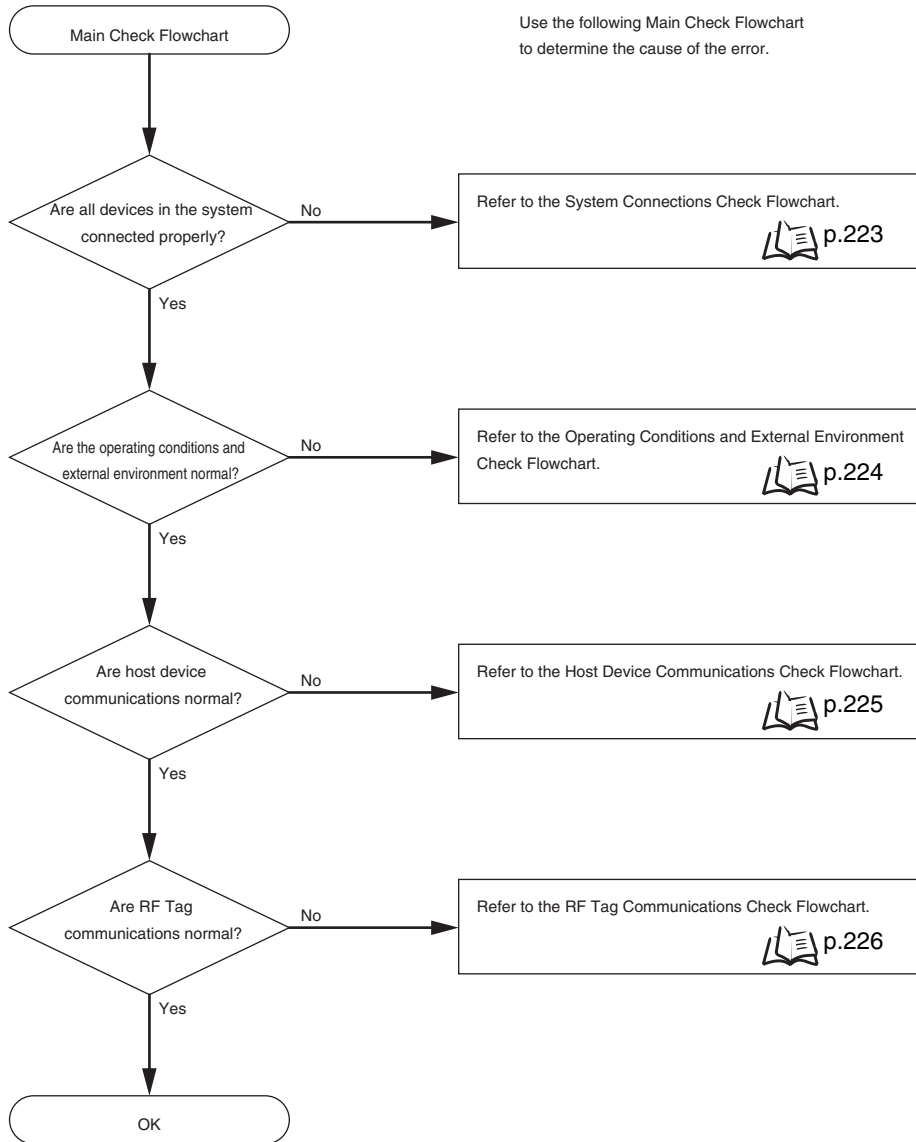

System Connections Check Flowchart

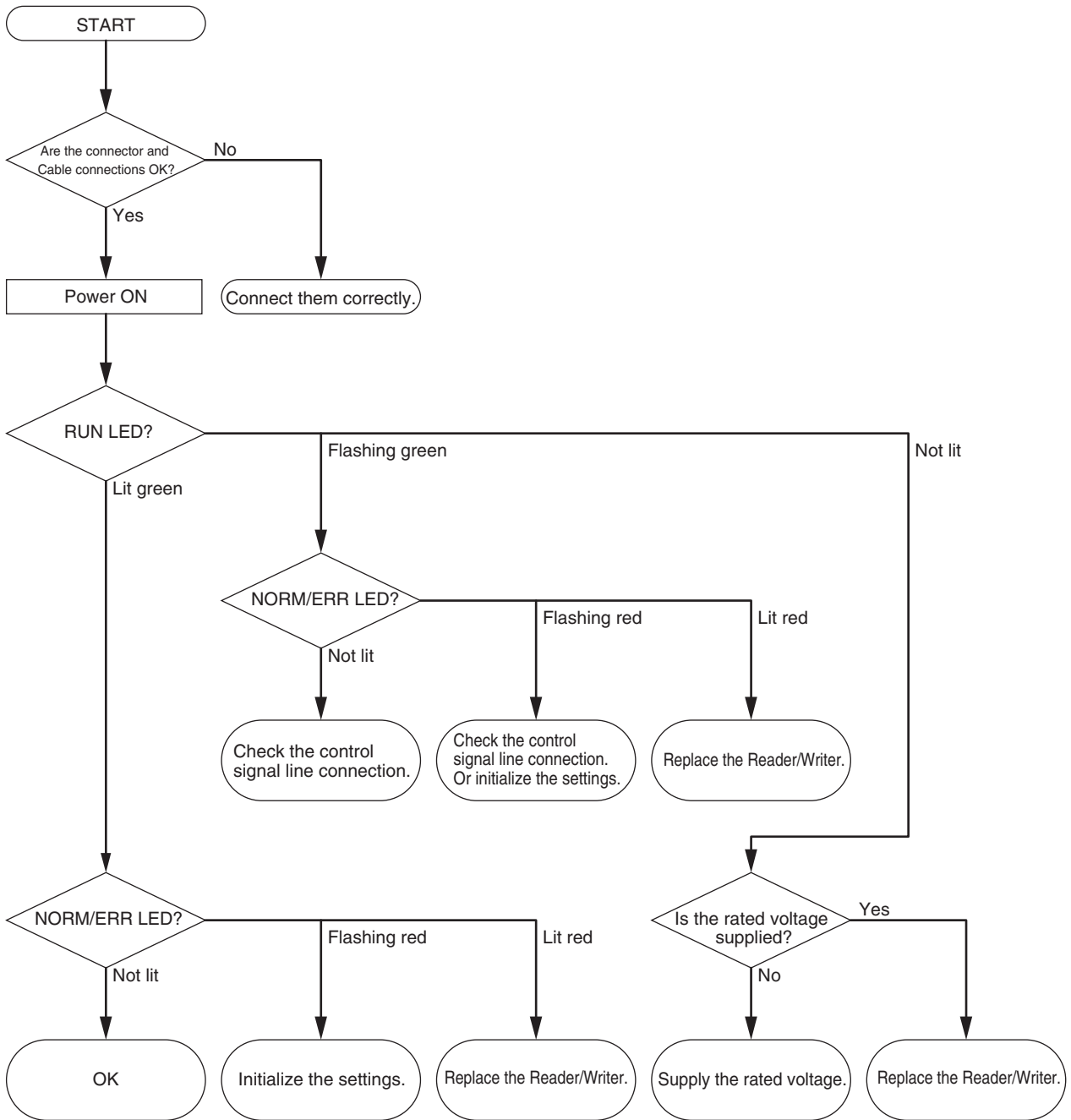

Operating Conditions and External Environment Check Flowchart

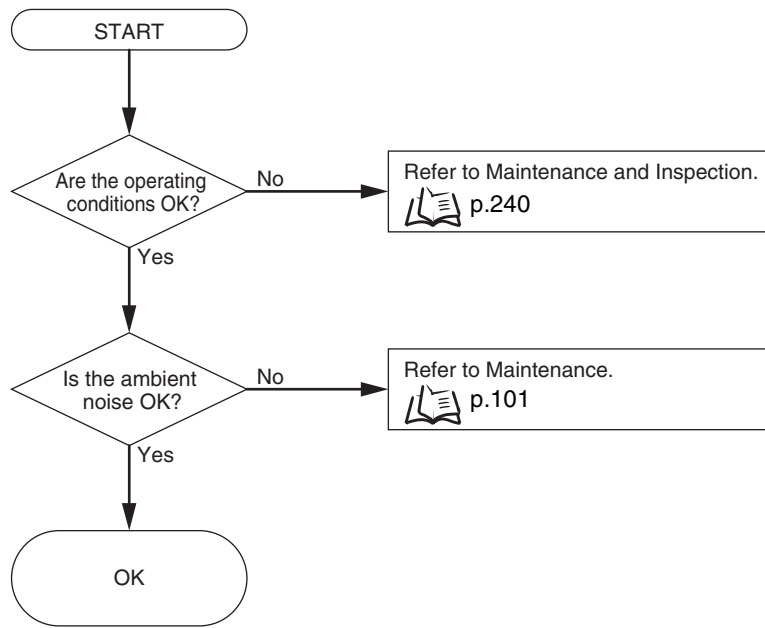

Host Device Communications Check Flowchart

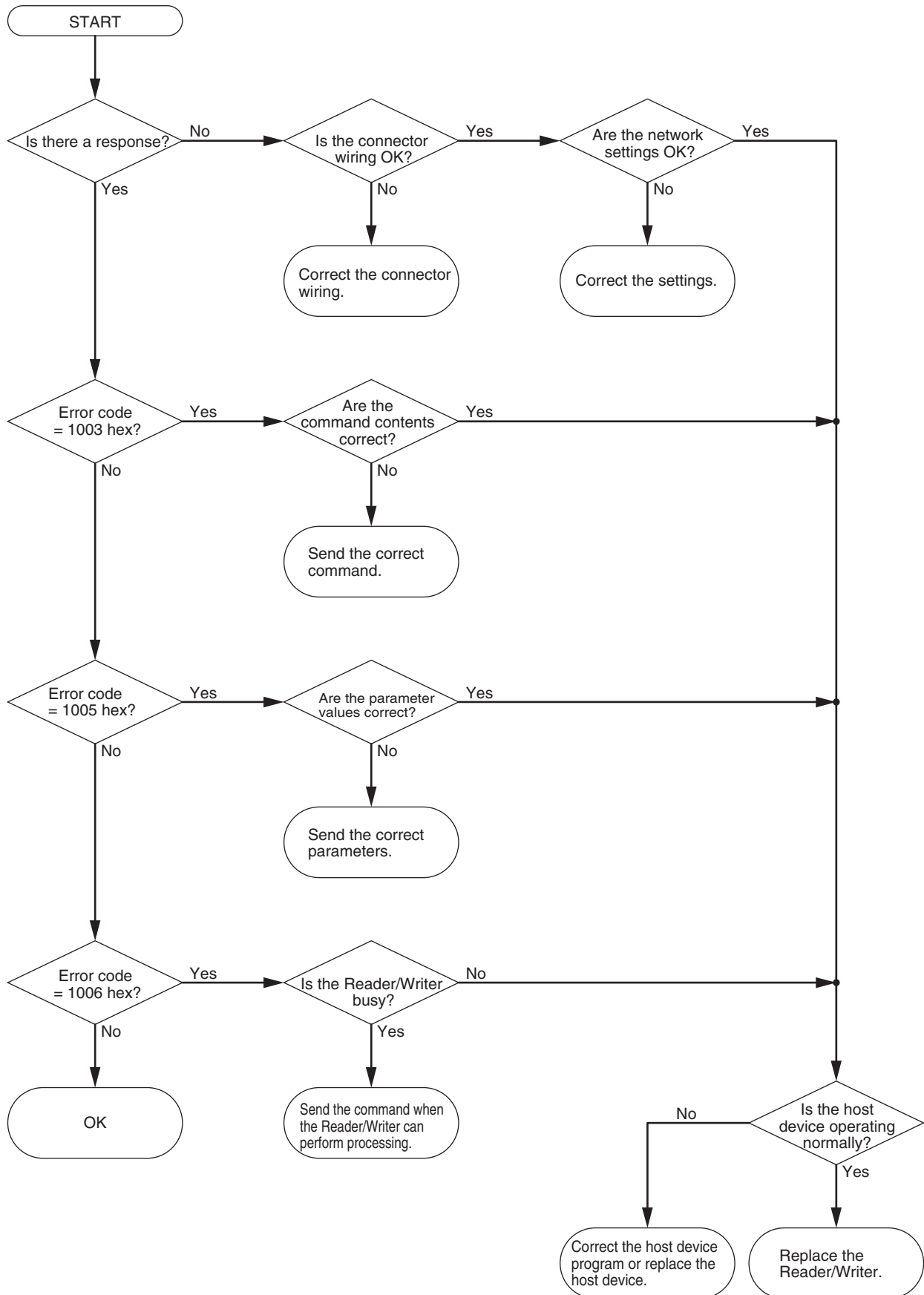

RF Tag Communications Check Flow

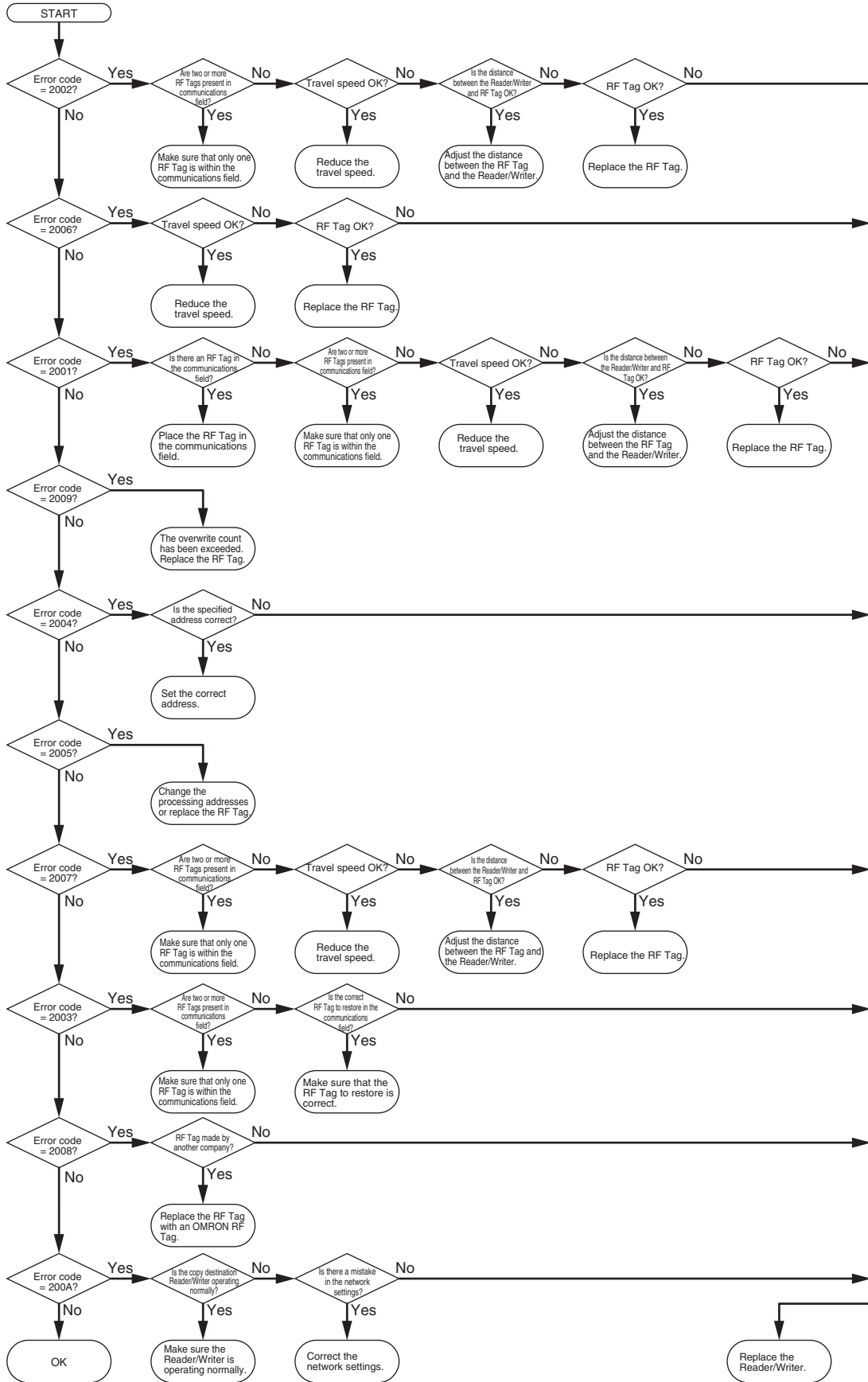

Refer to *RFID System Maintenance* in *Section 6 Functions*, when Communication Diagnosis is enabled and the diagnostic result is "Warning"

CHECK! p.108

About The Ethernet Communication Abnormality



CHECK!

If an Ethernet network is configured into a loop as shown below, broadcast packets are accumulated in the band, and the communication is disabled. Therefore, do not configure the Ethernet network into a loop.

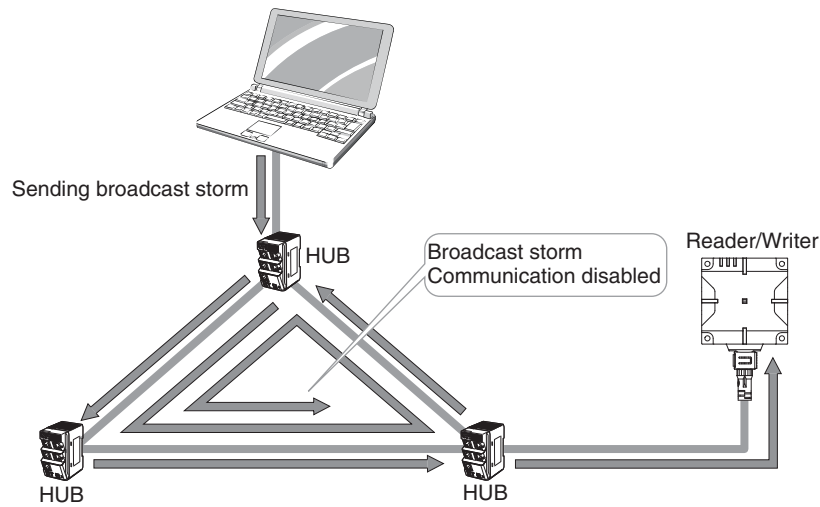

CHECK!

When a large amount of broadcast packets or multicast packets flow into the Ethernet network, Reader/Writers may stop its operation. Please do not send a large amount of packet. Please separate the Reader/Writers from the network segment that broadcast or multicast packets flow.

Cannot Display the Web Browser Operation Window

This section describes countermeasures when you cannot access the Reader/Writer Web browser interface (i.e., when you cannot display the operation window).

Only countermeasures that have been confirmed by OMRON are provided. They may not solve all possible problems. Contact your OMRON representative if you have problems that cannot be solved.

Problem

When the Web browser Reader/Writer interface is used to display the Web operation window, the OMRON logo is displayed and an error message is displayed instead of the operation menu.

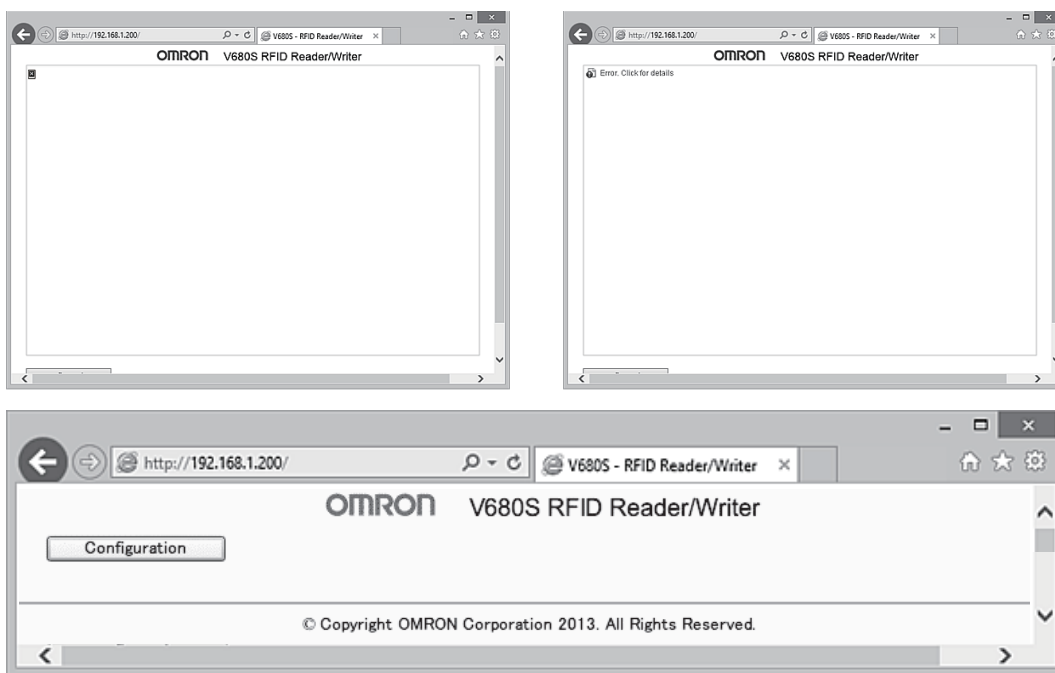

Solution

Check the message that appears when you try to start the Web browser interface, and then perform the corresponding procedure.

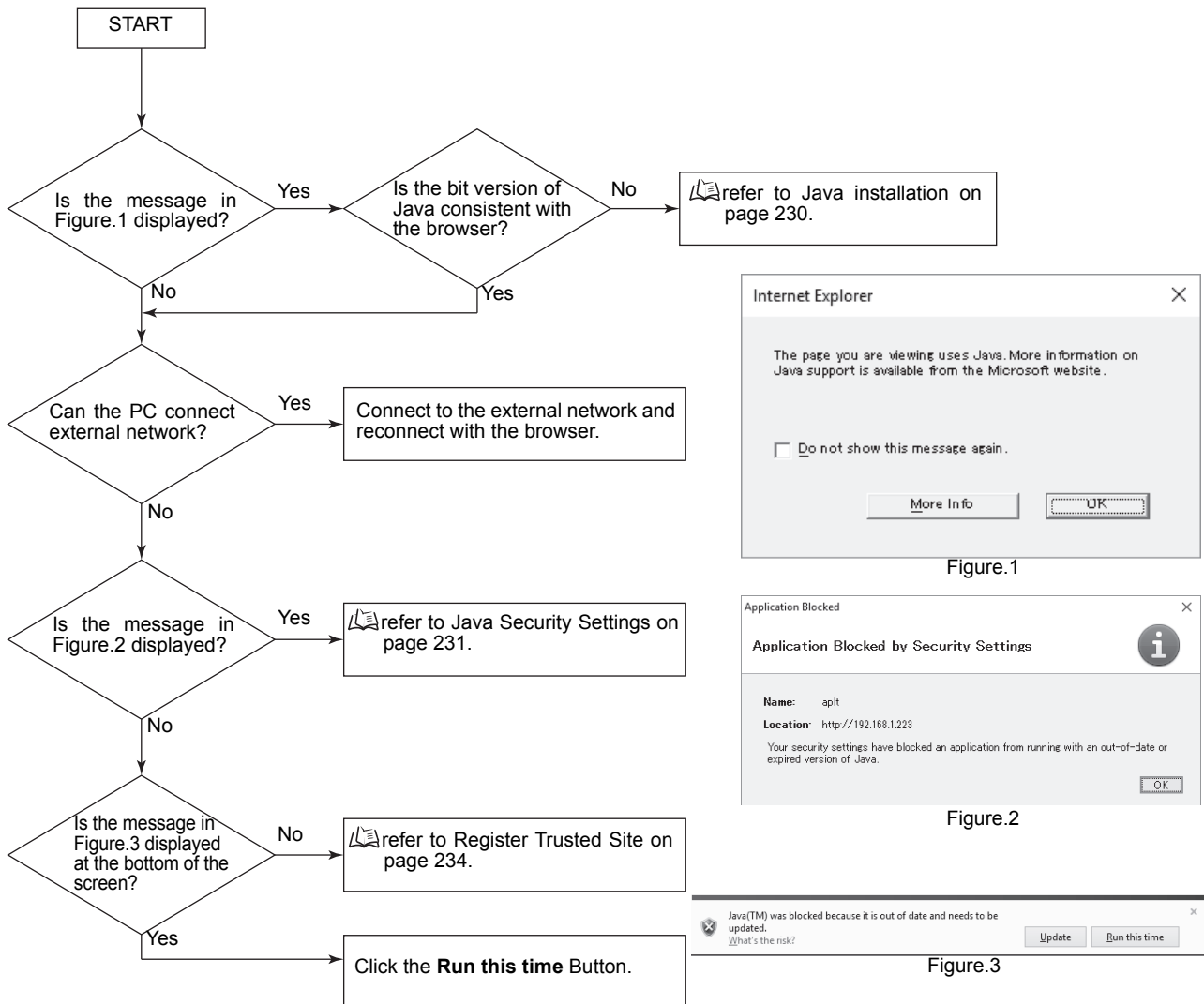

Java installation

Install Java bit version (64-bit or 32-bit) decided by the following flow.

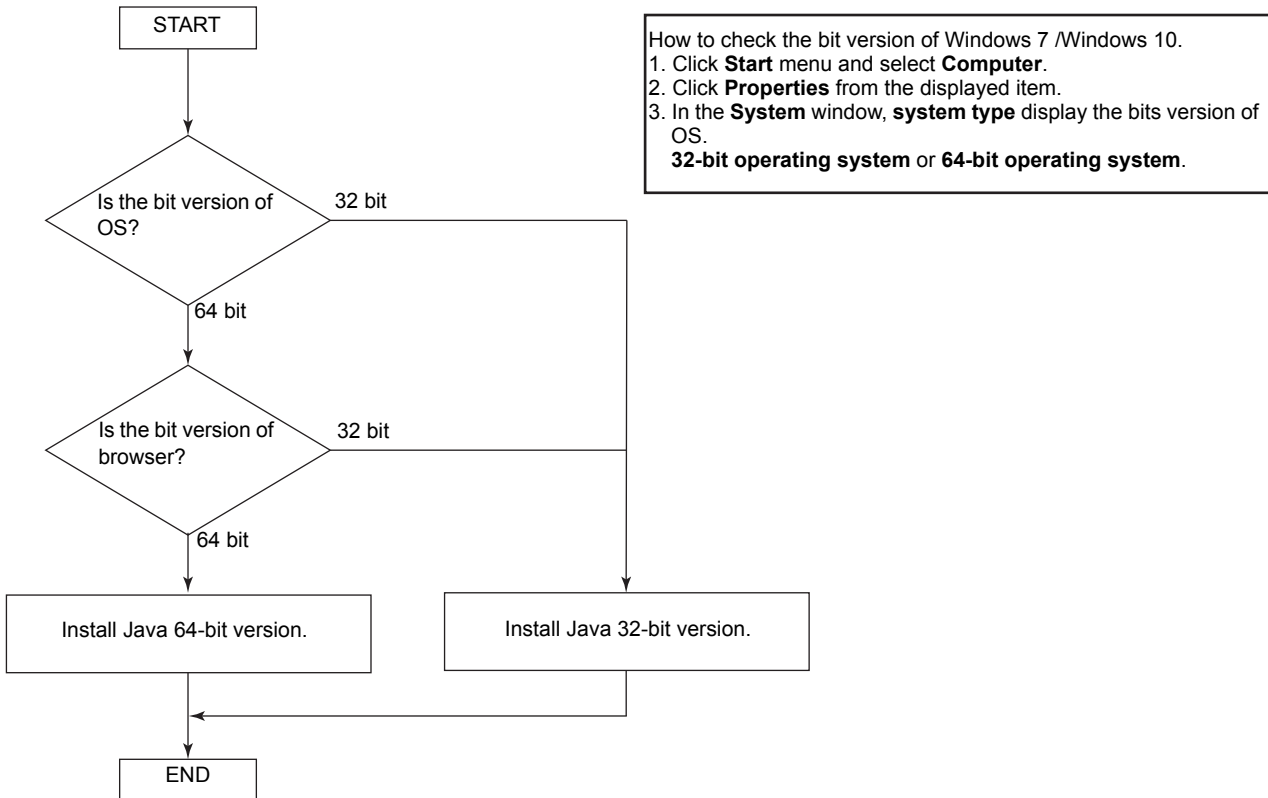

Java Security Settings

(1) Open the Control Panel and click the **Java** Icon.

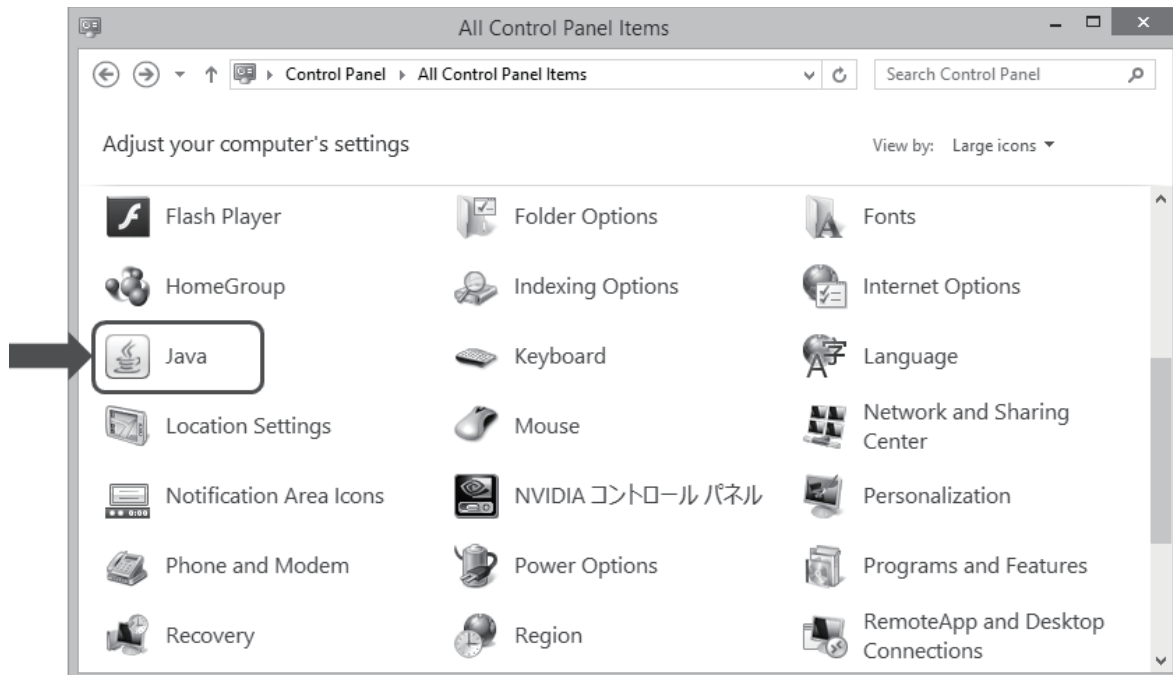

(2) Click the **Security** Tab and change the security level from high to medium.

* If the security settings are not displayed, refer to *Java Security Settings Are Not Displayed*.

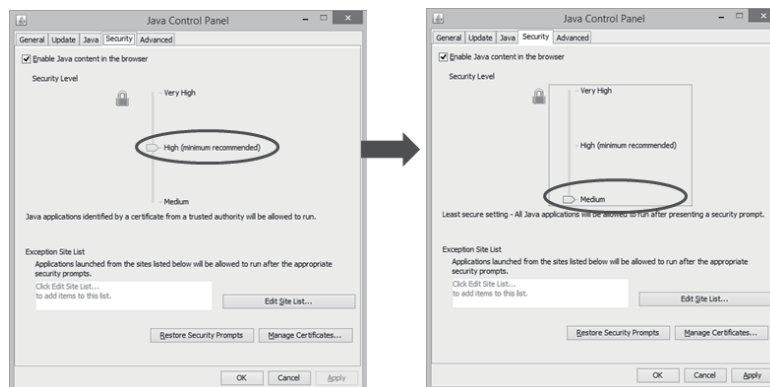

This procedure will reduce the security verification performed for execution of Java applications and therefore it may affect the execution of other Java applications.

(3) Restart the Web browser and access the IP address of the Reader/Writer again.

* The first time you access the IP address, the following message will be displayed. Click the **Execute** Button to display the window.

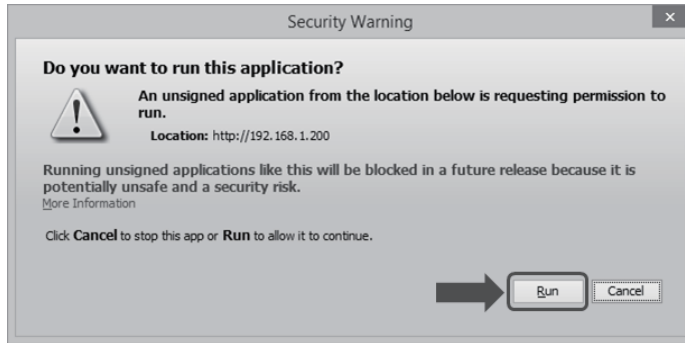

Java Security Settings Are Not Displayed

This section describes the countermeasure when the exception site list is not displayed and operation is not possible.

If the tab page to change Java security settings does not appear and you cannot change the settings when you select the **Security** Tab in step 2 of the procedure in *Countermeasure for Security Settings*, use the following procedure.

- (1) Open the Control Panel and uninstall all Java programs.
- (2) After you uninstall all of the programs, go to the following website and install Java.
<https://www.oracle.com/technetwork/java/archive-139210.html>
(*URL is as of April 2019 and may change in the future.)

Refer to *Browser Operation Window* for Java versions that can be used.



p.188



CHECK!

Java security features have been improved for the most recent version of Java, so the same problem may occur.

Register Trusted Site

- (1) Open the Web browser, click the **Tools** menu and select **Internet Options**.
- (2) Click the **Security** Tab, select Trusted sites and click **Sites** button.

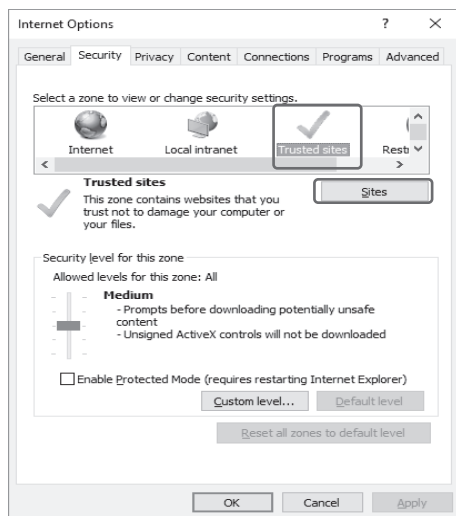

Java security features have been improved for the most recent version of Java, so the same problem may occur.

- CHECK!
- (3) In the **Add this Web site to the zone** box, enter the IP address of the target Reader/Writer, and then click **Add** button.
http://"IP address of target device"
ex) <http://192.168.1.200/>

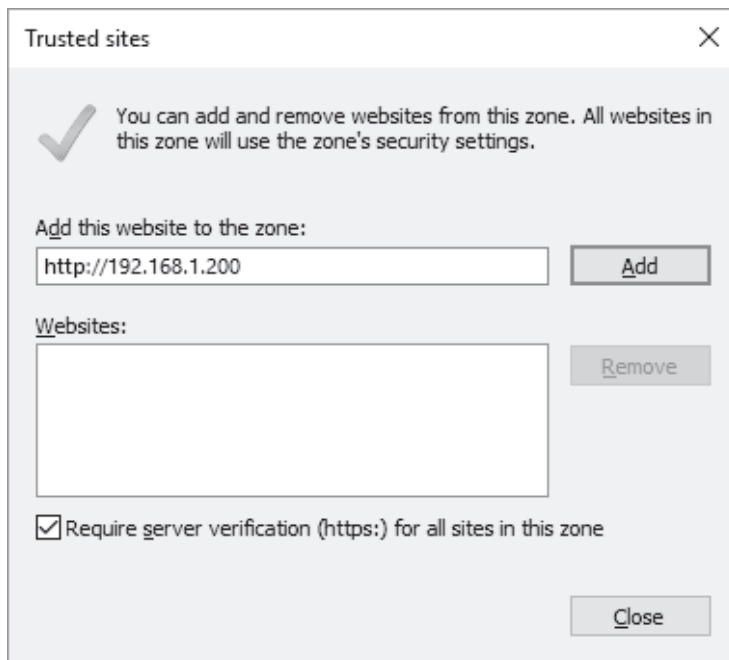

Countermeasures for Other Problems

(1) Open the Control Panel and click the **Java** Icon.

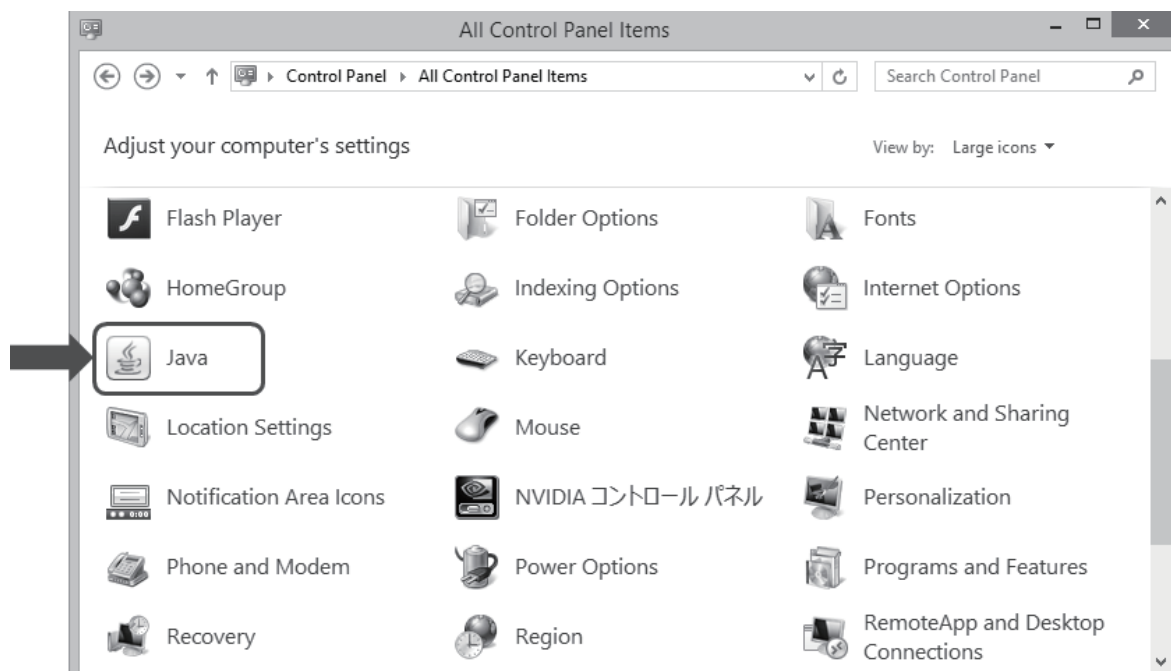

(2) Click the **Settings** Button in the Temporary Internet Files Area on the General Tab Page.

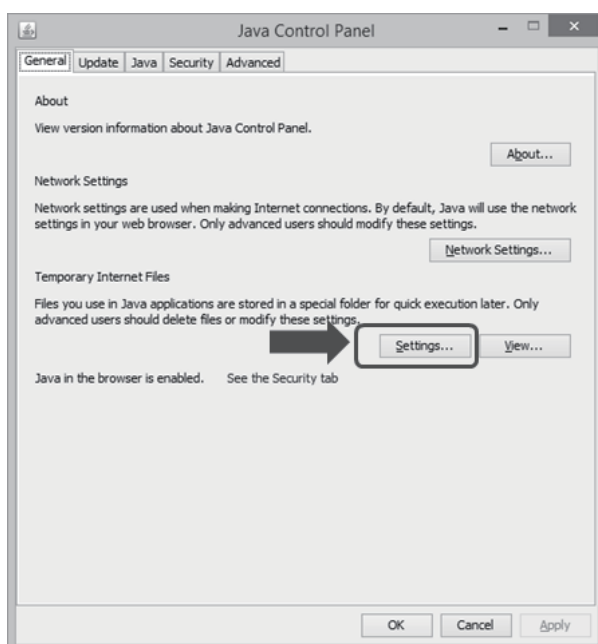

(3) Select the *Keep temporary files on my computer* Check Box and click the **Delete Files** Button.

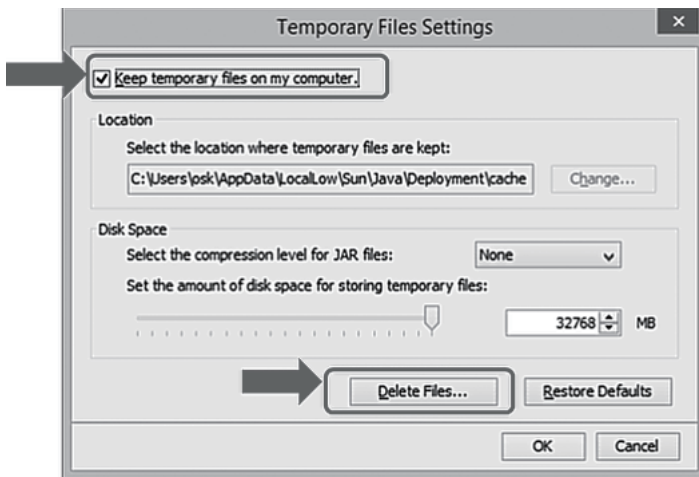

(4) Click the **OK** Button.

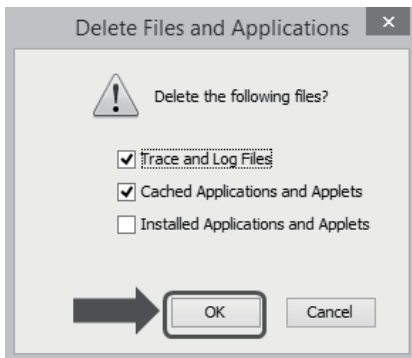

(5) When the files have been deleted, click the **OK** Button and close all windows. Then, restart the Web browser and connect to the Reader/Writer again.

Safe Mode

In addition to the Run Mode that is used for normal operation, the Reader/Writer supports a Safe Mode operation mode. The Safe Mode is used when you do not remember the IP address that is set in the Reader/Writer.

If the Reader/Writer starts in Safe Mode, the following settings are always used. This allows you to access the Reader/Writer even if you forget the IP address so that you can set the IP address again.

IP address	192.168.1.200
Subnet mask	255.255.255.0



When the Reader/Writer is running in safe mode, some functions can not be used (Ex. RF tag communication and noise measurement function, etc). When you use the Reader/Writer normally, please start the Reader/Writer in RUN mode.

CHECK!

Starting in Safe Mode

- (1) Connect the control signal line from the Cable to 0 V on the DC power supply. Connect the other two lines (24P and 24N) to the DC power supply terminals.
- (2) Turn ON the power supply to the Reader/Writer.
- (3) The RUN indicator on the Reader/Writer will flash green

After the Reader/Writer starts in Safe Mode, reset or initialize the IP address from the Web browser or host device.



CHECK!



If an error occurs in the Reader/Writer, the Reader/Writer may automatically start in Safe Mode. Refer to *Error Descriptions* in this Section for more information.

p.212

MEMO

Section 10

Maintenance and Inspection

 Maintenance and Inspection

240

Maintenance and Inspection

The Reader/Writer must be inspected on a daily or periodic basis so that the functions remain in good condition. The Reader/Writer consists of semiconductors that last almost indefinitely. The following malfunctions, however, may result due to the operating environment and conditions.

- (1) Element deterioration due to overvoltage or overcurrent.
- (2) Element deterioration due to continuous stress caused by high ambient temperature.
- (3) Connector contact faults or insulation deterioration due to humidity and dust.
- (4) Connector contact faults or element corrosion due to corrosive gas.

■ Inspection Items

No.	Inspection item	Details	Criteria	Remarks
1	Power supply voltage fluctuation	(1) Make sure that the supply voltage fluctuation at the power supply terminal block is within the permissible range.	Within supply voltage specified range	Multimeter
		(2) Make sure that there are no frequent instantaneous power failures or radical voltage fluctuations.	Within permissible voltage fluctuation range	Power supply analyzer
2	Ambient environment			Maximum and minimum thermometer Hygrometer
	(a) Temperature	(a) Within the specified range	(a) -10 to 55°C	
	(b) Humidity	(b) Within the specified range	(b) 25% to 85%	
	(c) Vibration and shock	(c) Influence of vibration or shock from machines	(c) Within the specified range	
	(d) Dust	(d) Make sure that the Reader/Writer is free of accumulated dust and foreign particles.	(d) Must not be present.	
	(e) Corrosive gas	(e) Make sure that no metal parts are discolored or corroded.	(e) Must not be present.	
3	Panel condition			---
	(a) Ventilation	(a) Make sure that the system is ventilated properly with natural ventilation, forced ventilation, or cooling air.	(a) The interior temperature must be between -10 and 55°C with proper ventilation.	
	(b) Damage to packing for any enclosing structure	(b) Make sure that the panel packing is properly attached with no damage.	(b) The packing must have no damage.	
4	Mounting conditions	(1) Make sure that the Reader/Writer is securely mounted.	No loose screws	---
		(2) Make sure that each connector is fully inserted.	Each connector must be locked or securely tightened with screws.	---
		(3) Make sure that no wire is broken or nearly broken.	Must be no wire that is broken or nearly broken.	---
		(4) Make sure that the distance between the RF Tags and Reader/Writer is within the specified range.	Within the specified range	---
5	RF Tag life	Manage the number of times data is written to each RF Tag.	The maximum number of overwrites must not be exceeded	---

Section 11

Appendices

☒ Data Characteristics	242
RF Tag Communications Range (for Reference Only)	242
RF Tag Communications Time (for Reference Only)	250
☒ Reader/Writer Installation Precautions	254
V680S-HMD63-EIP	254
V680S-HMD64-EIP	255
V680S-HMD66-EIP	257
☒ RF Tag Installation Precautions	259
V680-D1KP54T	259
V680-D1KP66T	262
V680-D1KP66MT	265
V680-D1KP66T-SP	268
V680-D1KP58HTN	272
V680S-D2KF67	274
V680S-D2KF67M	277
V680S-D8KF67	280
V680S-D8KF67M	283
V680S-D2KF68	286
V680S-D2KF68M	289
V680S-D8KF68	292
V680S-D8KF68M	295
☒ RF Tag Memory Capacities and Memory Types	298
☒ RF Tag Memory Map	299
☒ Chemical Resistance of the Reader/Writers and RF Tags	302
☒ Degree of Protection	306
☒ Differences in Address and Size Specifications between V680 and V680S Reader/Writers	308

Data Characteristics

RF Tag Communications Range (for Reference Only)

■ V680S-HMD63-EIP

(Unit: mm)

- V680S-HMD63-EIP and V680-D1KP54MT (Back Surface: Metal)

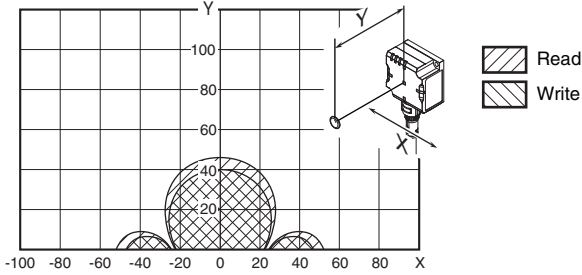

- V680S-HMD63-EIP and V680-D1KP66T (Back Surface: Metal)

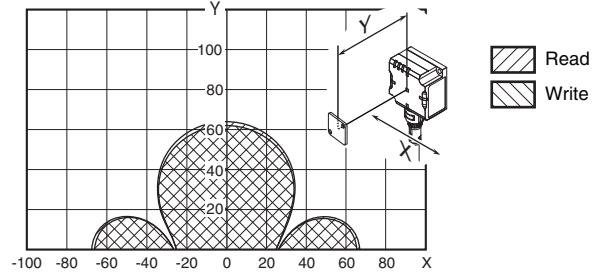

- V680S-HMD63-EIP and V680-D1KP66MT (Back Surface: Metal) (Back Surface: Metal)

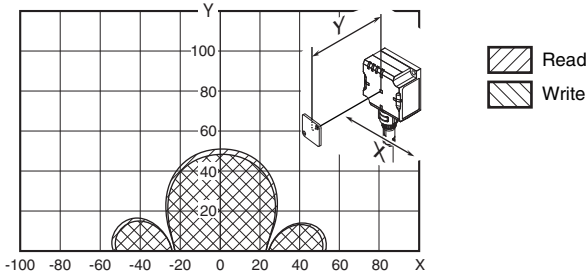

- V680S-HMD63-EIP and V680-D1KP66T-SP (Back Surface: Metal)

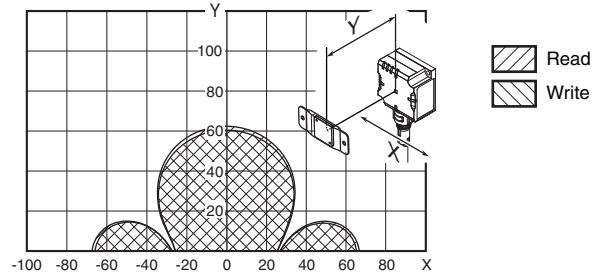

(Unit: mm)

- V680S-HMD63-EIP and V680S-D2KF67
(Back Surface: Metal)

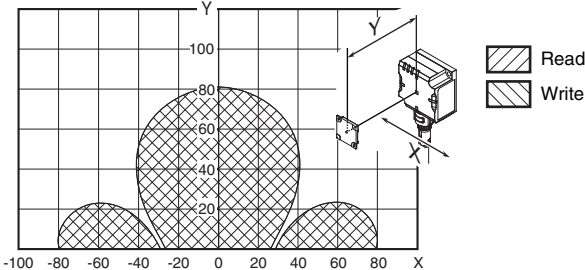

- V680S-HMD63-EIP and V680S-D2KF67M
(Back Surface: Metal)

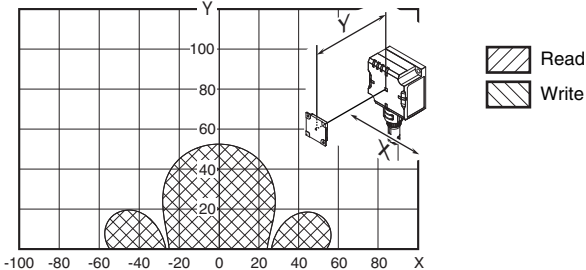

- V680S-HMD63-EIP and V680S-D8KF67
(Back Surface: Metal)

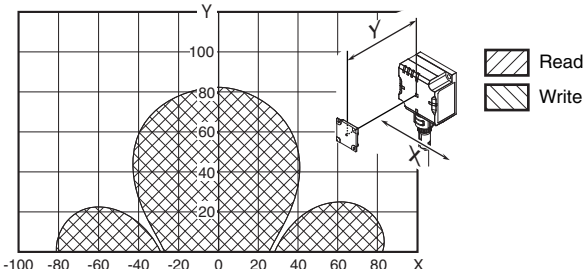

- V680S-HMD63-EIP and V680S-D8KF67M
(Back Surface: Metal) (Back Surface: Metal)

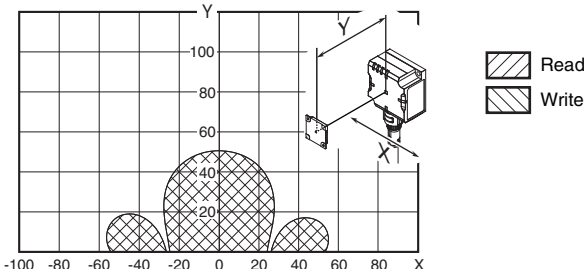

■ V680S-HMD64-EIP

(Unit: mm)

- V680S-HMD64-EIP and V680-D1KP54T
 (Back Surface: Metal)

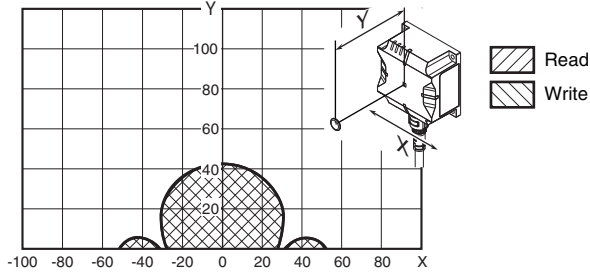

- V680S-HMD64-EIP and V680-D1KP66T
 (Back Surface: Metal)

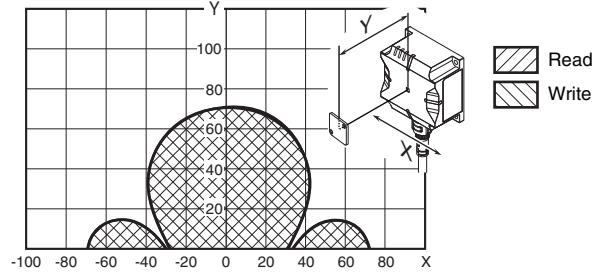

- V680S-HMD64-EIP and V680-D1KP66MT
 (Back Surface: Metal) (Back Surface: Metal)

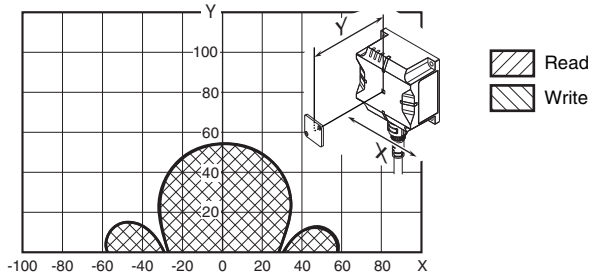

- V680S-HMD64-EIP and V680-D1KP66T-SP
 (Back Surface: Metal)

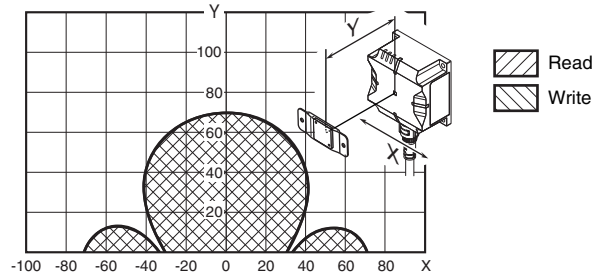

- V680S-HMD64-EIP and V680-D1KP58HTN
 (Back Surface: Metal) (with Attachment, V680-A80)

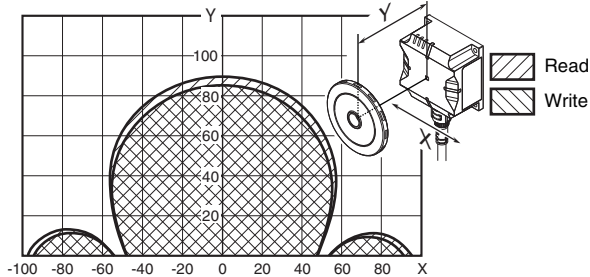

(Unit: mm)

● V680S-HMD64-EIP and V680S-D2KF67
(Back Surface: Metal)

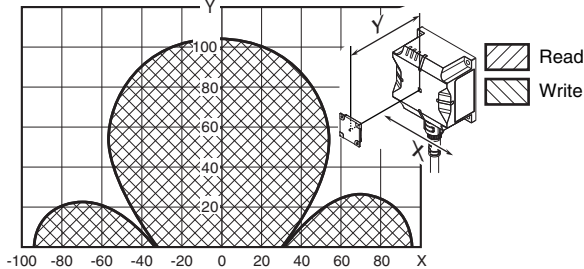

● V680S-HMD64-EIP and V680S-D2KF67M
(Back Surface: Metal) (Back Surface: Metal)

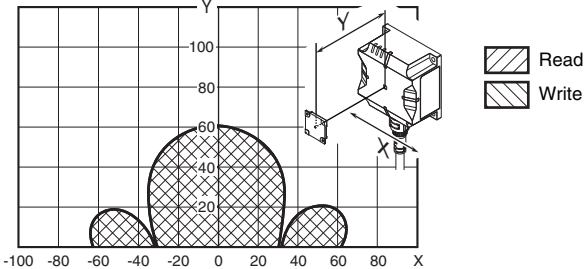

● V680S-HMD64-EIP and V680S-D8KF67
(Back Surface: Metal)

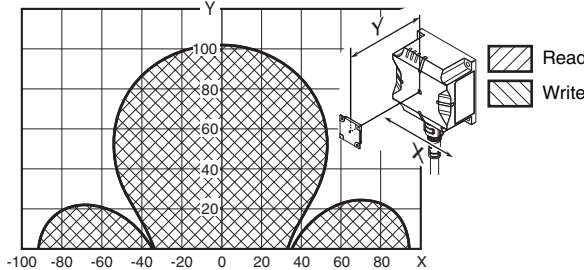

● V680S-HMD64-EIP and V680S-D8KF67M
(Back Surface: Metal) (Back Surface: Metal)

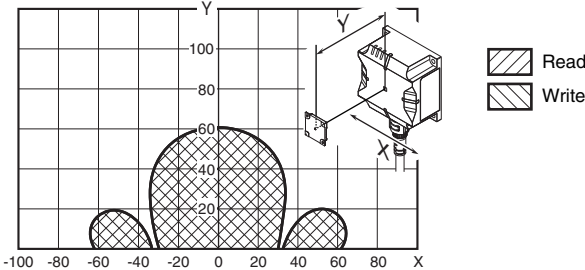

(Unit: mm)

- V680S-HMD64-EIP and V680S-D2KF68
(Back Surface: Metal) (Horizontal-facing RF Tag)

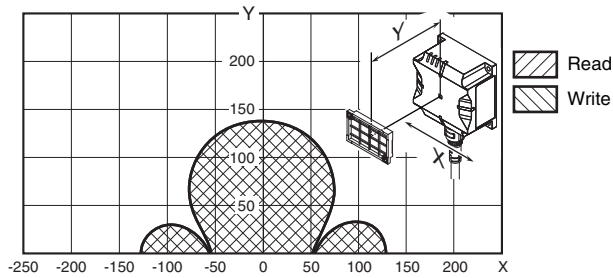

- V680S-HMD64-EIP and V680S-D2KF68
(Back Surface: Metal) (Vertical-facing RF Tag)

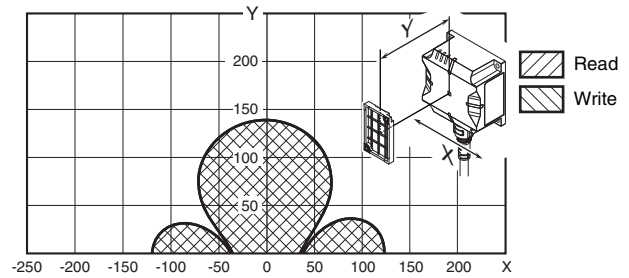

- V680S-HMD64-EIP and V680S-D2KF68M
(Back Surface: Metal) (Back Surface: Metal)
(Horizontal-facing RF Tag)

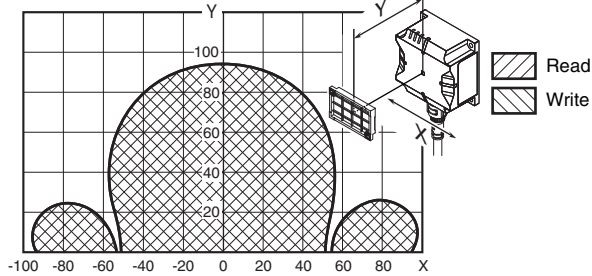

- V680S-HMD64-EIP and V680S-D2KF68M
(Back Surface: Metal) (Back Surface: Metal)
(Vertical-facing RF Tag)

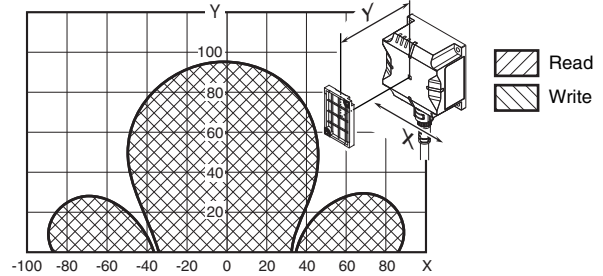

- V680S-HMD64-EIP and V680S-D8KF68
(Back Surface: Metal) (Horizontal-facing RF Tag)

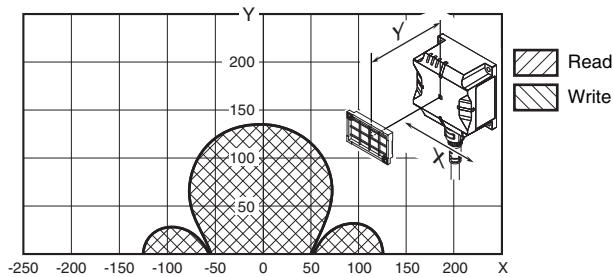

- V680S-HMD64-EIP and V680S-D8KF68
(Back Surface: Metal) (Vertical-facing RF Tag)

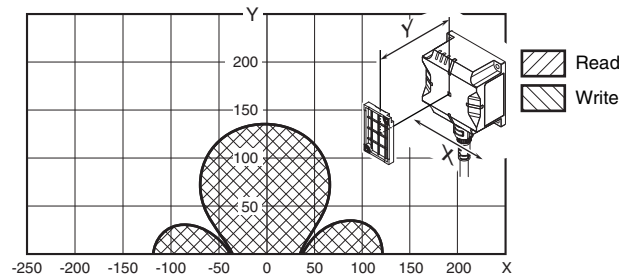

- V680S-HMD64-EIP and V680S-D8KF68M
(Back Surface: Metal) (Back Surface: Metal)
(Horizontal-facing RF Tag)

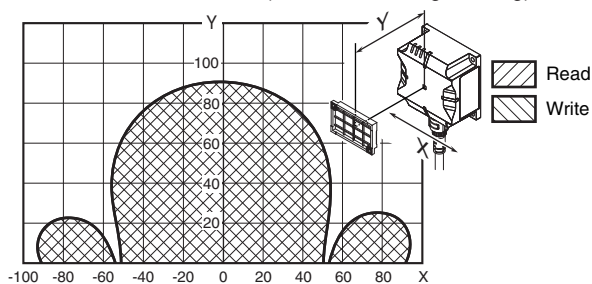

- V680S-HMD64-EIP and V680S-D8KF68M
(Back Surface: Metal) (Back Surface: Metal)
(Vertical-facing RF Tag)

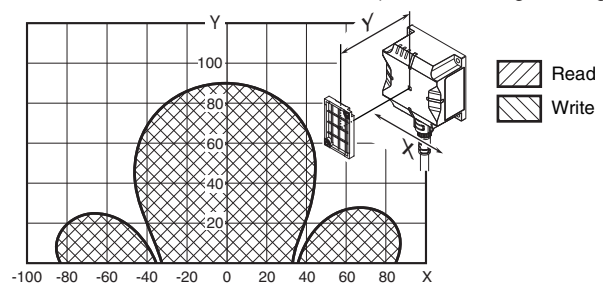

■ V680S-HMD66-EIP

(Unit: mm)

● V680S-HMD66-EIP and V680-D1KP54T
(Back Surface: Metal)

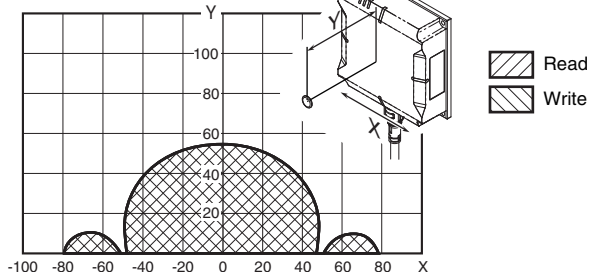

● V680S-HMD66-EIP and V680-D1KP66T
(Back Surface: Metal)

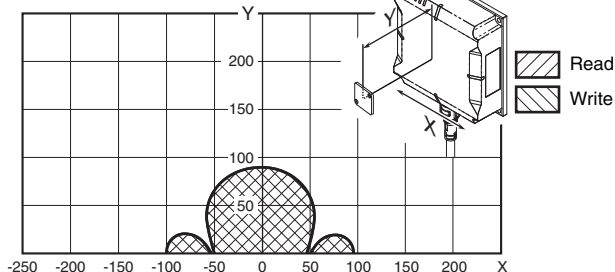

● V680S-HMD66-EIP and V680-D1KP66MT
(Back Surface: Metal) (Back Surface: Metal)

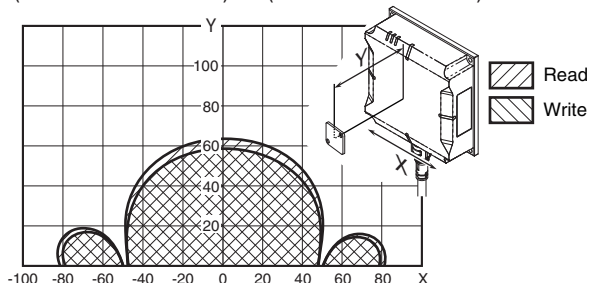

● V680S-HMD66-EIP and V680-D1KP66T-SP
(Back Surface: Metal)

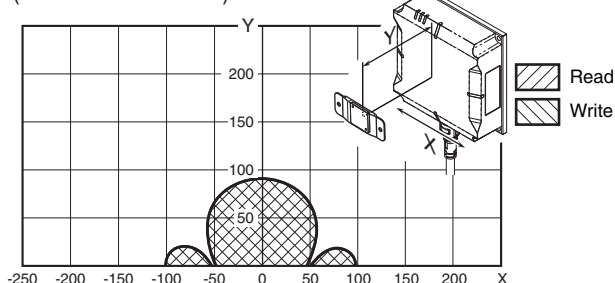

V680S-HMD66-EIP and V680-D1KP58HTN
(Back Surface: Metal) (with Attachment, V680-A80)

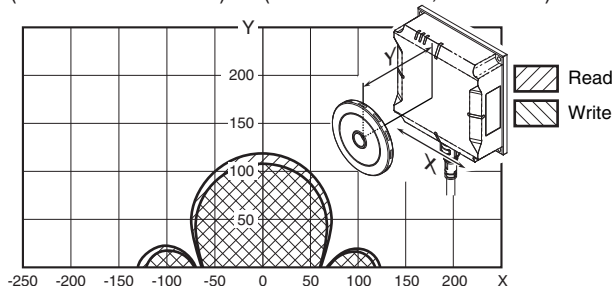

(Unit: mm)

● V680S-HMD66-EIP and V680S-D2KF67
(Back Surface: Metal)

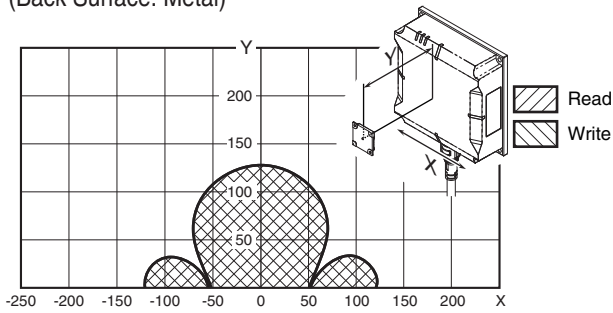

● V680S-HMD66-EIP and V680S-D2KF67M
(Back Surface: Metal) (Back Surface: Metal)

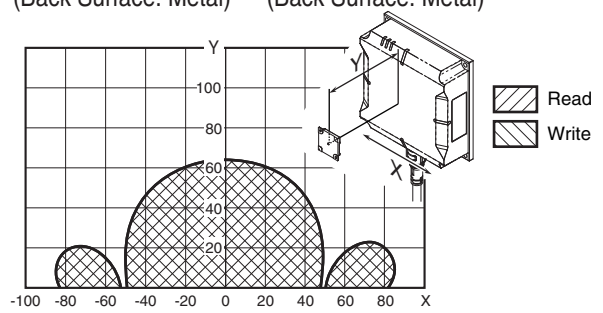

● V680S-HMD66-EIP and V680S-D8KF67
(Back Surface: Metal)

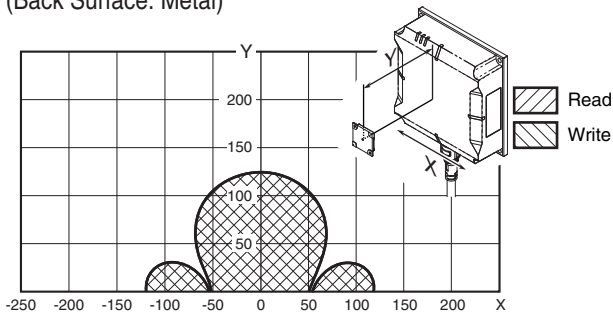

● V680S-HMD66-EIP and V680S-D8KF67M
(Back Surface: Metal) (Back Surface: Metal)

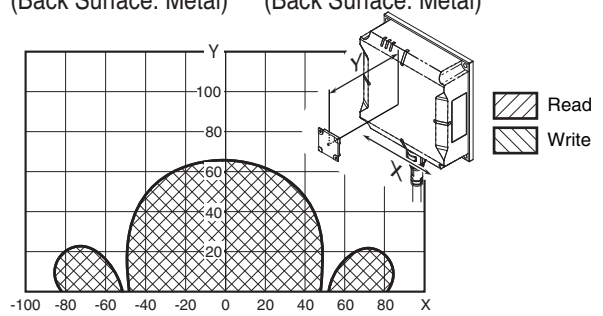

(Unit: mm)

● V680S-HMD66-EIP and V680S-D2KF68
(Back Surface: Metal) (Horizontal-facing RF Tag)

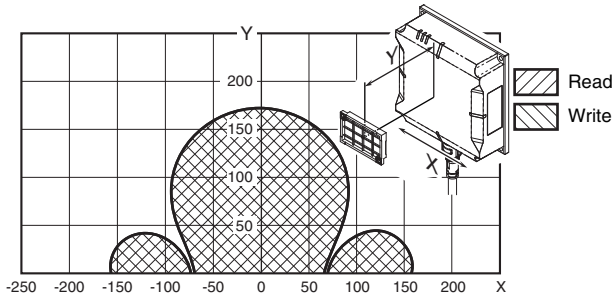

● V680S-HMD66-EIP and V680S-D2KF68
(Back Surface: Metal) (Vertical-facing RF Tag)

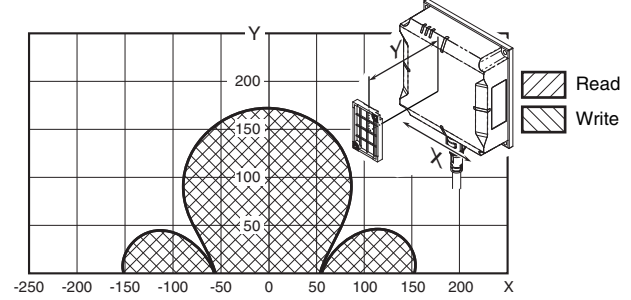

● V680S-HMD66-EIP and V680S-D2KF68M
(Back Surface: Metal) (Back Surface: Metal)
(Horizontal-facing RF Tag)

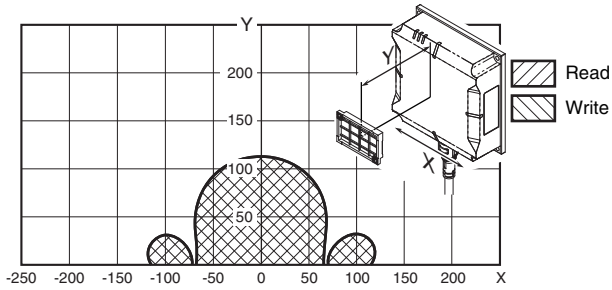

● V680S-HMD66-EIP and V680S-D2KF68M
(Back Surface: Metal) (Back Surface: Metal)
(Vertical-facing RF Tag)

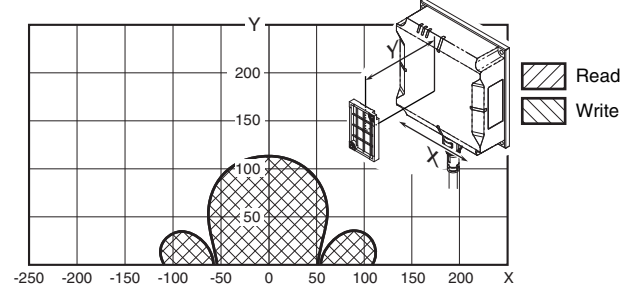

● V680S-HMD66-EIP and V680S-D8KF68
(Back Surface: Metal) (Horizontal-facing RF Tag)

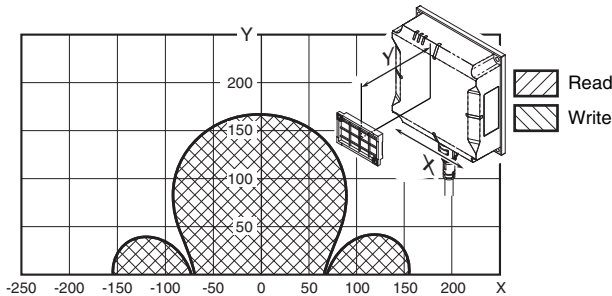

● V680S-HMD66-EIP and V680S-D8KF68
(Back Surface: Metal) (Vertical-facing RF Tag)

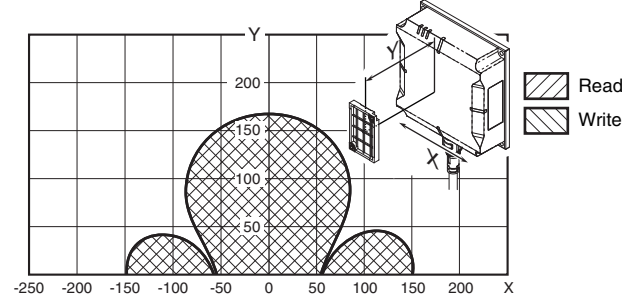

● V680S-HMD66-EIP and V680S-D8KF68M
(Back Surface: Metal) (Back Surface: Metal)
(Horizontal-facing RF Tag)

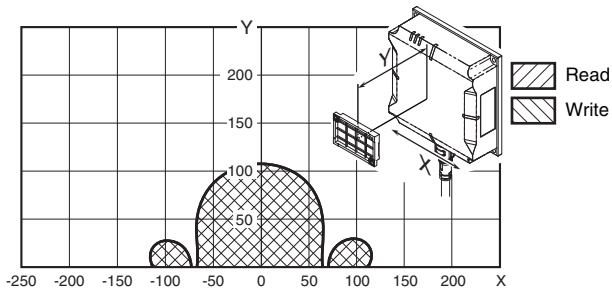

● V680S-HMD66-EIP and V680S-D8KF68M
(Back Surface: Metal) (Back Surface: Metal)
(Vertical-facing RF Tag)

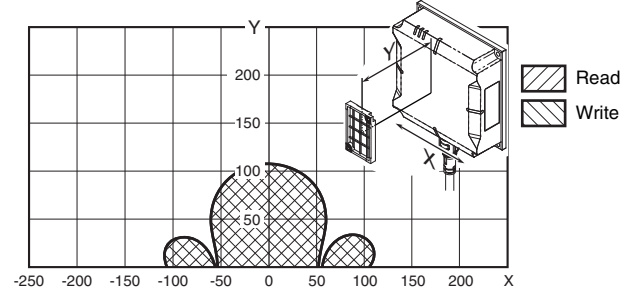

RF Tag Communications Time (for Reference Only)

■ Communications Time

Communications time is from the rise of the RF signal to the last bit of the response from the RF tag.

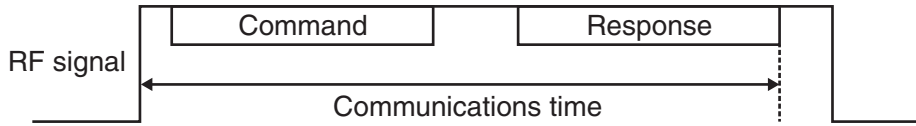

- RF signal : The radio wave that the Reader/Writer turns ON the RF Tag.
The Reader/Writer turns ON this RF signal and then sends the command to start communications with the RF tag.
When the communications end, the Reader/Writer turns OFF the RF signal
- Command : The command that the Reader/Writer sends to the RF Tag.
- Response : The response that the RF Tag returns to the Reader/Writer.



The communication time is approximately 200ms longer when enabling Communications Diagnosis function.

V680S-HMD6□-EIP and V680-D1KP□□

There are no differences between Communication speed: “normal” and “high”.

Command	Communications time (ms) N: No. of bytes processed
Read	$T = 1.0N + 20.1$
Write (with verification)	$T = 1.8N + 45.2$
Write (without verification)	$T = 1.5N + 41.4$

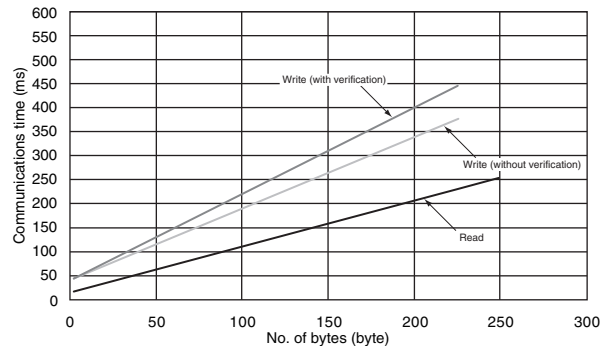

V680S-HMD6□-EIP and V680S-D2KF6□ (Communications speed setting: High speed)

- Communication Option: Other than FIFO Repeat (With ID code check)

Command	Communications time (ms) N: No. of bytes processed
Read	$T = 0.4N + 17.4$
Write (with verification)	$T = 1.0N + 51.9$
Write (without verification)	$T = 0.7N + 35.2$

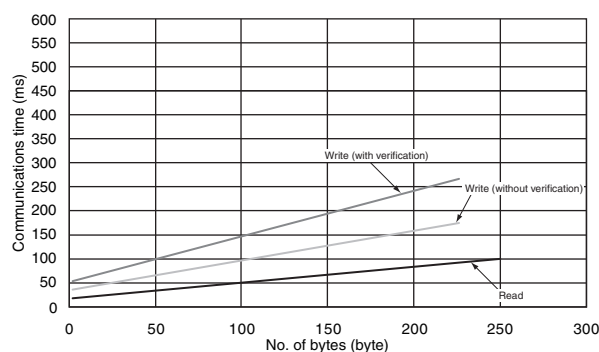

- Communication Option: FIFO Repeat (With ID code check)

Command	Communications time (ms) N: No. of bytes processed
Read	$T = 0.4N + 24.8$
Write (with verification)	$T = 1.2N + 76.1$
Write (without verification)	$T = 0.8N + 51.6$

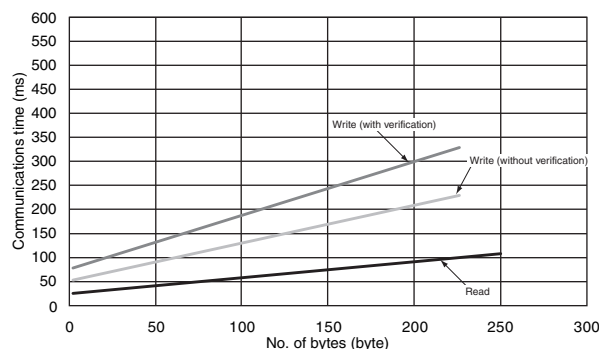

V680S-HMD6□-EIP and V680S-D8KF6□ (Communications speed setting: High speed)

- Communication Option: Other than FIFO Repeat (With ID code check)

Command	Communications time (ms) N: No. of bytes processed
Read	$T = 0.4N + 33.0$
Write (with verification)	$T = 0.9N + 95.1$
Write (without verification)	$T = 0.5N + 65.8$

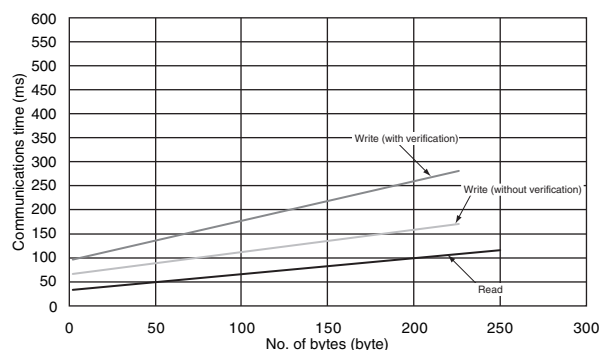

- Communication Option: FIFO Repeat (With ID code check)

Command	Communications time (ms) N: No. of bytes processed
Read	$T = 0.4N + 40.4$
Write (with verification)	$T = 1.0N + 116.5$
Write (without verification)	$T = 0.6N + 45.8$

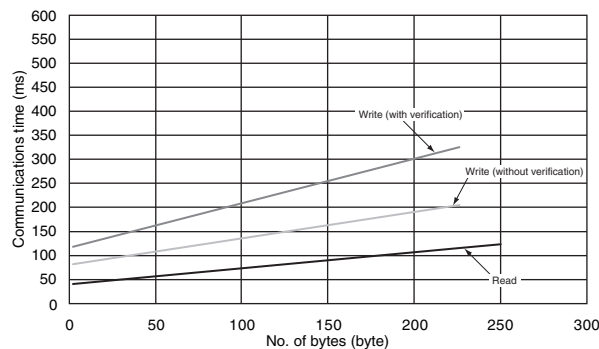

V680S-HMD6□-EIP and V680S-D2KF6□ (Communications speed setting: Normal speed)

- Communication Option: Other than FIFO Repeat (With ID code check)

Command	Communications time (ms) N: No. of bytes processed
Read	$T = 0.9N + 18.7$
Write (with verification)	$T = 1.7N + 42.1$
Write (without verification)	$T = 0.9N + 32.0$

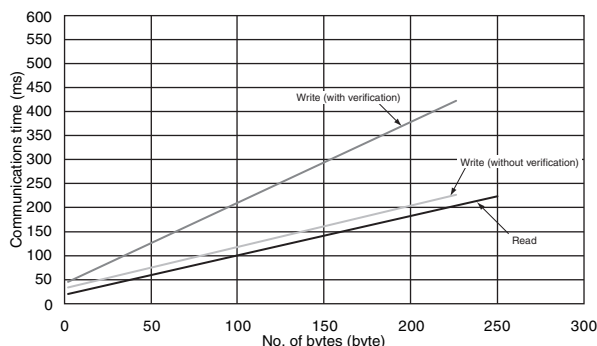

- Communication Option: FIFO Repeat (With ID code check)

Command	Communications time (ms) N: No. of bytes processed
Read	$T = 1.2N + 27.3$
Write (with verification)	$T = 2.4N + 60.2$
Write (without verification)	$T = 1.2N + 46.4$

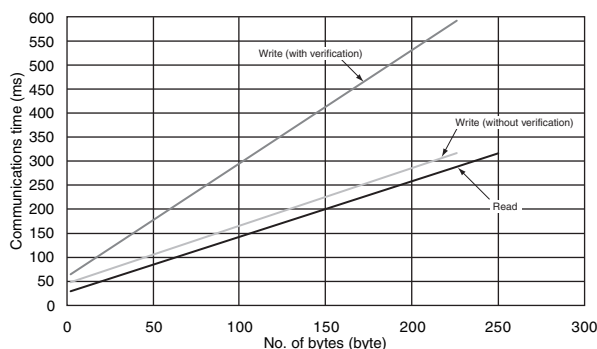

V680S-HMD6□-EIP and V680S-D8KF6□ (Communications speed setting: Normal speed)

- Communication Option: Other than FIFO Repeat (With ID code check)

Command	Communications time (ms) N: No. of bytes processed
Read	$T = 0.5N + 36.1$
Write (with verification)	$T = 1.0N + 93.0$
Write (without verification)	$T = 0.5N + 65.8$

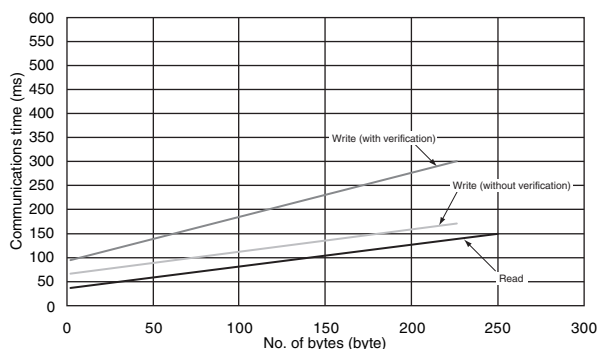

- Communication Option: FIFO Repeat (With ID code check)

Command	Communications time (ms) N: No. of bytes processed
Read	$T = 0.6N + 45.8$
Write (with verification)	$T = 1.1N + 113.1$
Write (without verification)	$T = 0.6N + 80.8$

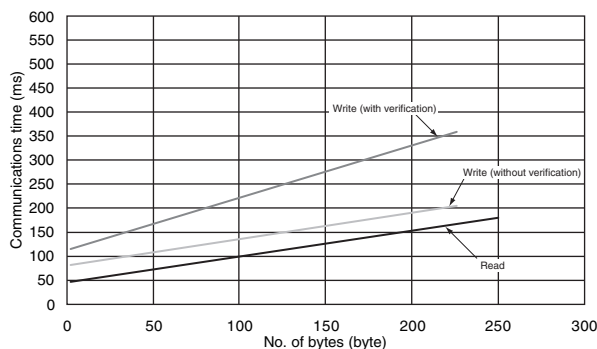

Travel Speed Calculations

Set the communications option to Repeat to communicate with a moving RF Tag.

The maximum speed for communicating with the RF Tag can be calculated simply using the following formula.

$$\text{Maximum speed} = \frac{D \text{ (Distance traveled in communications field)}}{T \text{ (Communications time)}}$$

D (Distance traveled in communications field) is calculated from the actual measurement or the communications field between the Reader/Writer and RF Tag.



CHECK!

In order to ensure a margin, it is preferable that the communication time is calculated at twice.

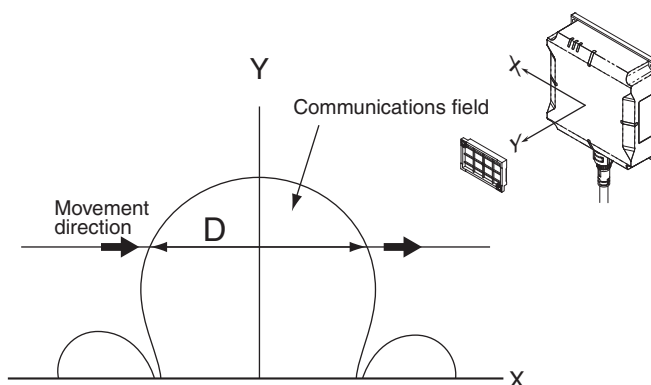

Calculation Example

The following example is for reading 128 bytes with the V680S-D2KF68 and V680S-HMD66-EIP.

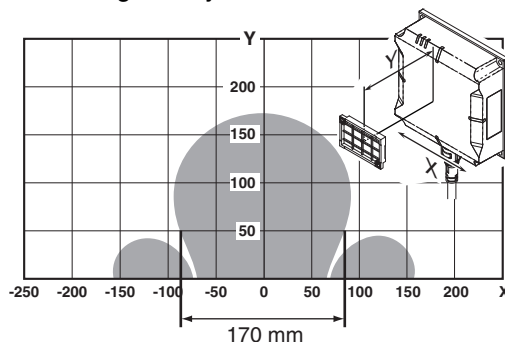

From the above chart,

Distance traveled in communications field = 170 mm when Y (communications range) is 50 mm

Communications time T = 267.8 ms (calculated from the communications time, i.e., 2 times × (0.9 × 128 bytes + 18.7))

Therefore, the maximum speed of the Tag is as follows:

$$\begin{aligned} \text{Maximum speed} &= \frac{D \text{ (Distance traveled in communications field)}}{T \text{ (Communications time)}} = \frac{170(\text{mm})}{267.8(\text{ms})} \\ &= 38.1 \text{ m/min} \end{aligned}$$

Reader/Writer Installation Precautions

V680S-HMD63-EIP

■ Influence of Surrounding Metal on Reader/Writer

The Reader/Writer can be surface-mounted or it can be embedded in metal to protect it from collisions. If you embed the Reader/Writer in metal, separate it at least 80 mm from any metallic surface to prevent malfunctions. If the distance between surrounding metal and the Reader/Writer is less than 80 mm, the Reader/Writer communications range will be greatly reduced. Do not allow the height of the metal to exceed the height of the Reader/Writer.

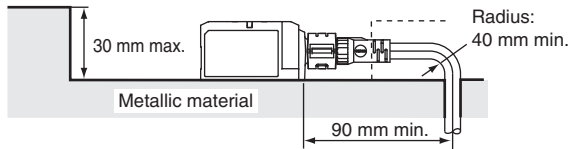

Provide a Cable bending radius of 40 mm or more.

CHECK!



The communications range will be reduced significantly if the Reader/Writer is installed closer than 80 mm to metal surfaces.

CHECK!

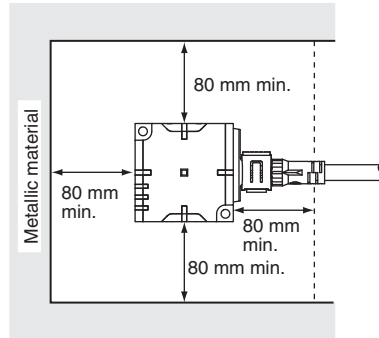

■ Mutual Interference of Reader/Writers

To prevent malfunctioning due to mutual interference when using more than one Reader/Writer, leave sufficient space between them as given in the following table.

If the distance between the Reader/Writers is too short, the read/write distances will be reduced.

RF Tag model	Mounting distance	
	Installing the Reader/Writers facing each other	Installing the Reader/Writers in parallel
V680-D1KP54T	230 mm	110 mm
V680-D1KP66T	300 mm	100 mm
V680-D1KP66MT	220 mm	100 mm
V680-D1KP66T-SP	300 mm	100 mm
V680S-D2KF67	370 mm	120 mm
V680S-D2KF67M	220 mm	100 mm
V680S-D8KF67	290 mm	120 mm
V680S-D8KF67M	240 mm	100 mm

- Installing the Reader/Writers Facing Each Other

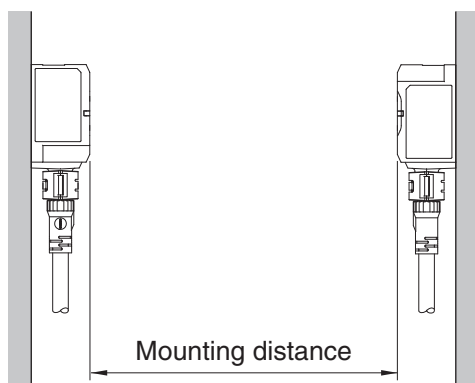

- Installing the Reader/Writers in Parallel

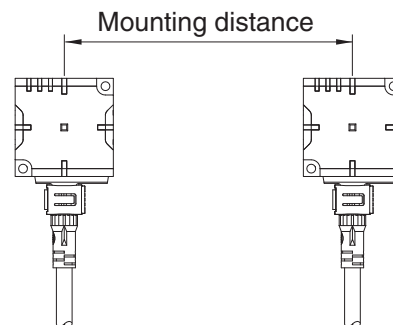

V680S-HMD64-EIP

■ Influence of Surrounding Metal on Reader/Writer

The Reader/Writer can be surface-mounted or it can be embedded in metal to protect it from collisions. If you embed the Reader/Writer in metal, separate it at least 100 mm from any metallic surface to prevent malfunctions. If the distance between surrounding metal and the Reader/Writer is less than 100 mm, the Reader/Writer communications range will be greatly reduced. Do not allow the height of the metal to exceed the height of the Reader/Writer.

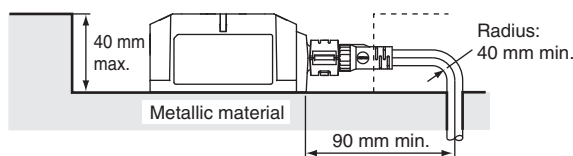

Provide a Cable bending radius of 40 mm or more.

CHECK!



The communications range will be reduced significantly if the Reader/Writer is installed closer than 100 mm to metal surfaces.

CHECK!

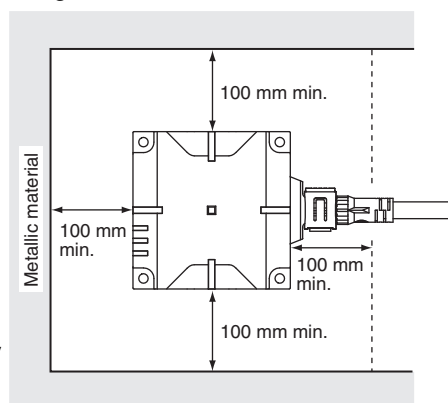

■ Mutual Interference of Reader/Writers

To prevent malfunctioning due to mutual interference when using more than one Reader/Writer, leave sufficient space between them as shown in the following diagrams.

If the distance between the Reader/Writers is too short, read / write distance will be reduced.

RF Tag model	Mounting distance	
	Installing the Reader/Writer facing each other	Installing the Reader/Writer in parallel
V680-D1KP54T	250 mm	125 mm
V680-D1KP66T	350 mm	150 mm
V680-D1KP66MT	250 mm	150 mm
V680-D1KP66T-SP	350 mm	150 mm
V680-D1KP58HTN	450 mm	125 mm
V680S-D2KF67	460 mm	170 mm
V680S-D2KF67M	220 mm	160 mm
V680S-D8KF67	400 mm	170 mm
V680S-D8KF67M	180 mm	160 mm
V680S-D2KF68	600 mm	180 mm
V680S-D2KF68M	380 mm	160 mm
V680S-D8KF68	600 mm	180 mm
V680S-D8KF68M	260 mm	160 mm

- Installing the Reader/Writer Facing Each Other

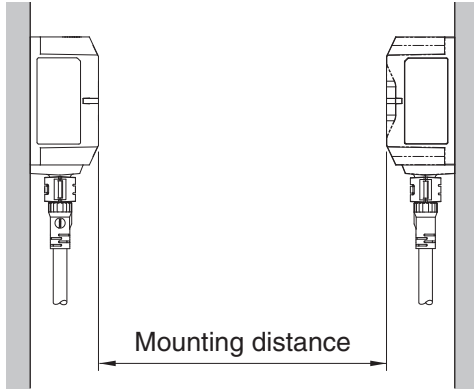

- Installing the Reader/Writer in Parallel

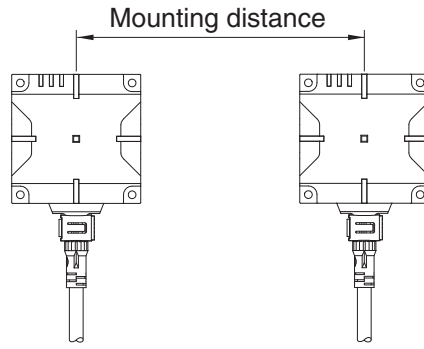

V680S-HMD66-EIP

■ Influence of Surrounding Metal on Reader/Writer

The Reader/Writer can be surface-mounted or it can be embedded in metal to protect it from collisions. If you embed the Reader/Writer in metal, separate it at least 160 mm from any metallic surface to prevent malfunctions. If the distance between surrounding metal and the Reader/Writer is less than 160 mm, the Reader/Writer communications range will be greatly reduced. Do not allow the height of the metal to exceed the height of the Reader/Writer.

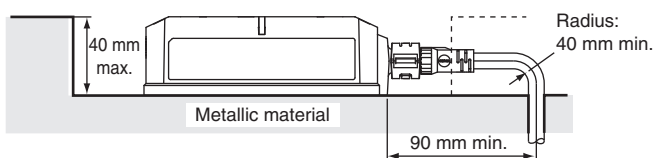

Provide a Cable bending radius of 40 mm or more.

CHECK!



The communications range will be reduced significantly if the Reader/Writer is installed closer than 160 mm to metal surfaces.

CHECK!

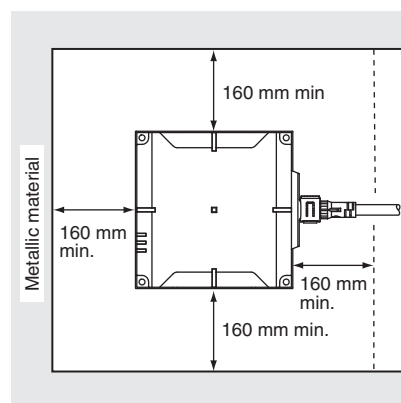

■ Mutual Interference of Reader/Writers

To prevent malfunctioning due to mutual interference when using more than one Reader/Writer, leave sufficient space between them as shown in the following diagrams.

If the distance between the Reader/Writers is too short, read / write distance will be reduced.

RF Tag model	Mounting distance	
	Installing the Reader/Writer facing each other	Installing the Reader/Writer in parallel
V680-D1KP54T	340 mm	190 mm
V680-D1KP66T	410 mm	190 mm
V680-D1KP66MT	300 mm	180 mm
V680-D1KP66T-SP	410 mm	190 mm
V680-D1KP58HTN	500 mm	170 mm
V680S-D2KF67	460 mm	230 mm
V680S-D2KF67M	300 mm	230 mm
V680S-D8KF67	580 mm	250 mm
V680S-D8KF67M	280 mm	220 mm
V680S-D2KF68	750 mm	220 mm
V680S-D2KF68M	420 mm	220 mm
V680S-D8KF68	600 mm	240 mm
V680S-D8KF68M	360 mm	220 mm

• Reader/Writers Installed Facing Each Other

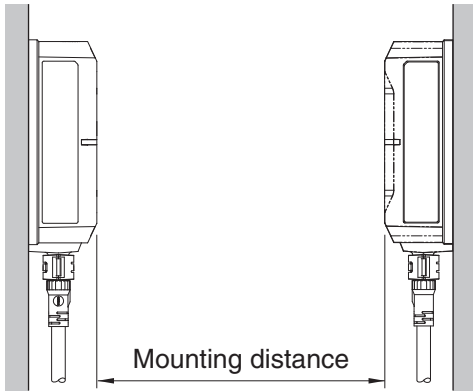

• Reader/Writers Installed in Parallel

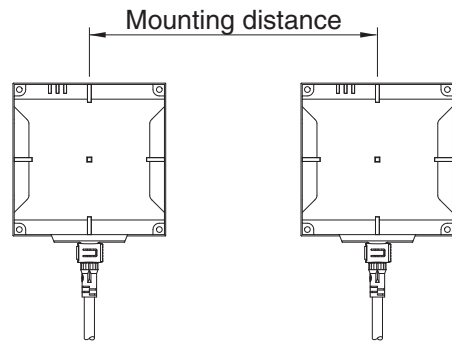

RF Tag Installation Precautions

V680-D1KP54T

Effect of Metal behind RF Tags

The communications range will decrease if there is metal at the back of the V680-D1KP54T RF Tag. The V700-A80 Attachment is 8 mm thick. If the RF Tag is mounted on metallic material, use a non-metallic spacer (e.g., plastic or resin). The following graphs show the relationship between the distance from the RF Tag to the metallic surface and the communications range.

The V700-A80 Attachment is 8 mm thick.

● V680S-HMD63-EIP and V680-D1KP54T

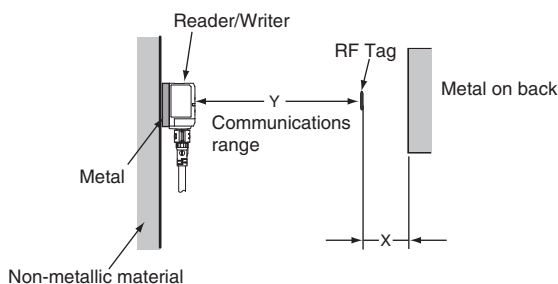
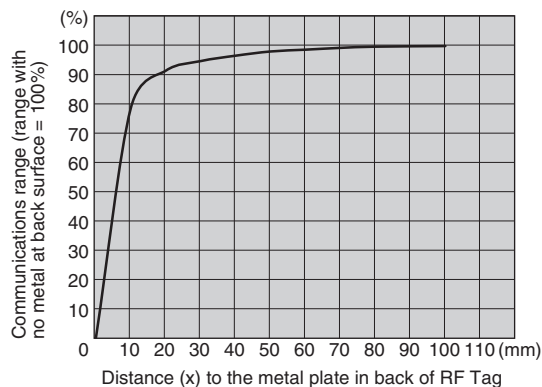

● V680S-HMD64-EIP and V680-D1KP54T

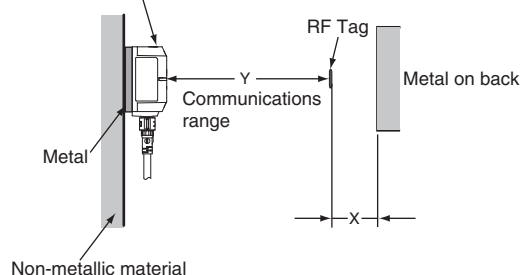
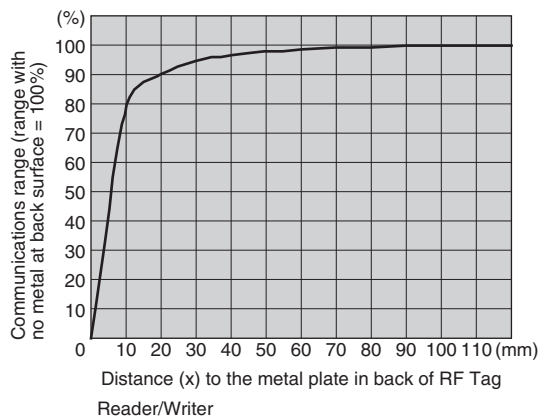

● V680S-HMD66-EIP and V680-D1KP54T

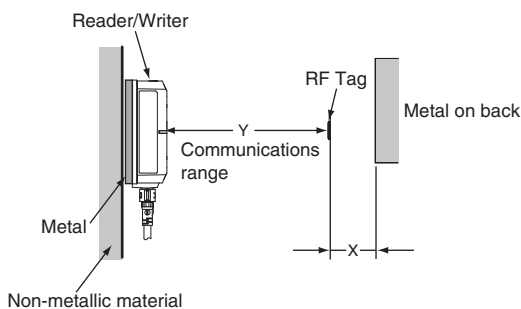
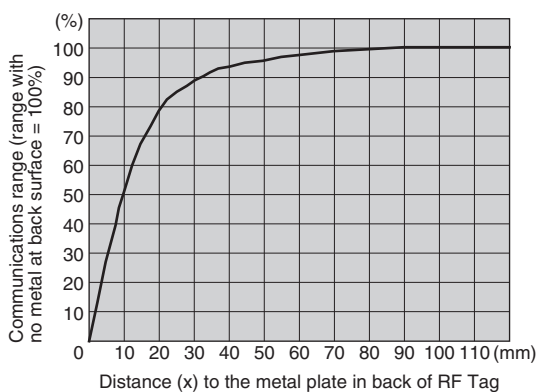

■ Mutual Interference of RF Tags

If you use more than one RF Tag, separate them by at least the interval shown below to prevent malfunctions due to mutual interference.

If the distance between the RF tags is too short, read / write distance will be reduced.

■ V680S-HMD63-EIP Reader/Writer

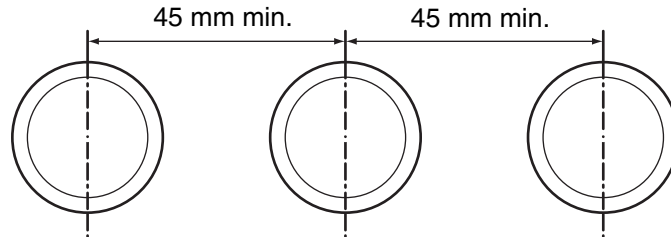

■ V680S-HMD64-EIP Reader/Writer

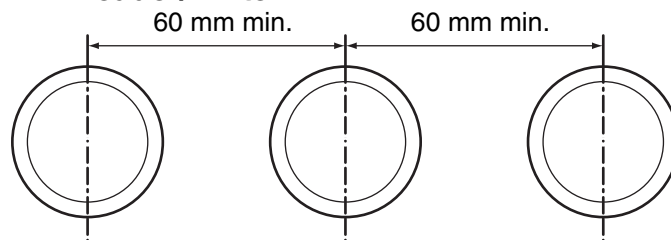

■ V680S-HMD66-EIP Reader/Writer

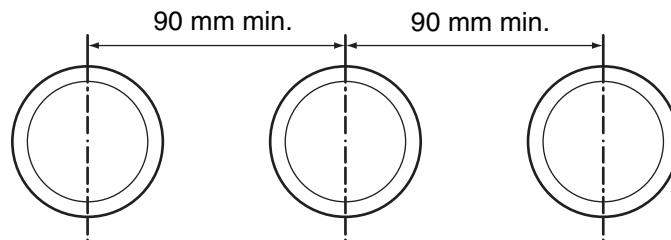

■ Influence of Inclination

Install the Reader/Writer and RF Tags so that the Reader/Writer and RF Tags are as parallel to each other as possible.

Communications will be possible even if the Reader/Writer and RF Tags are not parallel to each other; however, the communications range is affected by the inclination between them as shown in the following graphs.

■ Rates of Change in Communications Range for Inclination of V680-D1KP54T

	RF Tag inclination (θ°)									
	0	10	20	30	40	50	60	70	80	90
V680S-HMD63-EIP and V680-D1KP66T	0%	0%	-2%	-5%	-9%	-14%	-21%	-32%	-49%	---
V680S-HMD64-EIP and V680-D1KP54T	0%	-1%	-3%	-6%	-12%	-19%	-29%	-43%	-70	---
V680S-HMD66-EIP and V680-D1KP54T	0%	-1%	-3%	-6%	-11%	-18%	-27%	-42%	-67	---

■ Measurement Conditions

" V680S-HMD63-EIP and V680-D1KP54T

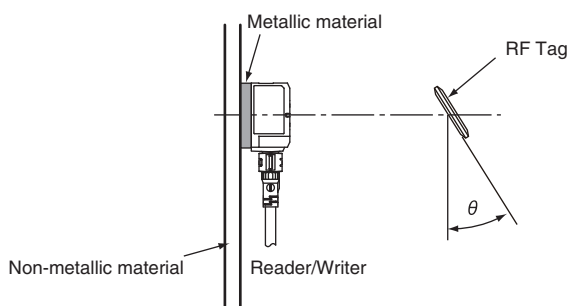

" V680S-HMD64-EIP and V680-D1KP54T

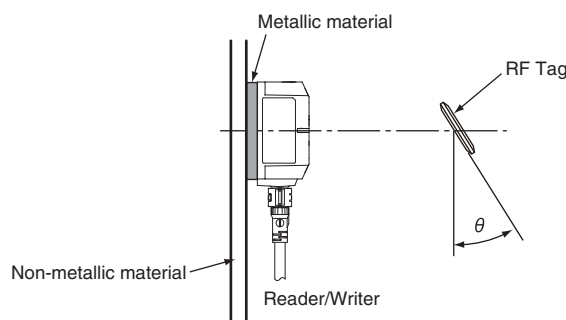

" V680S-HMD66-EIP and V680-D1KP54T

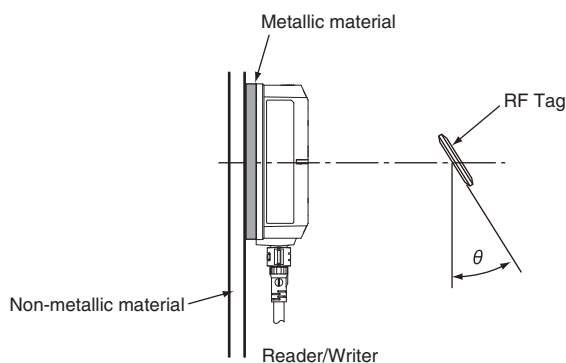

V680-D1KP66T

■ Influence of Metal at Back Surface

The communications range will decrease if there is metal at the back of the V680-D1KP66T RF Tag. If the RF Tag is mounted on metallic material, use the V600-A86 Attachment (sold separately) or insert a non-metallic spacer (e.g., plastic or resin). The following graphs show the relationship between the distance from the RF Tag to the metallic surface and the communications range.

You can also use more than one Attachment (10 mm).

Installation with the V600-A86 Attachment

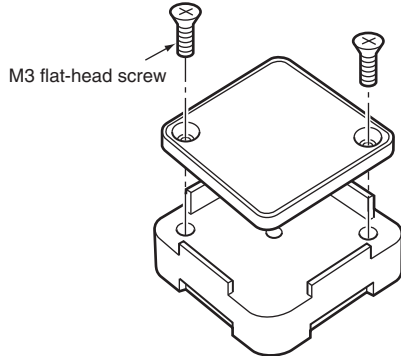

Note: Orient the RF Tag so that the mounting holes are aligned.

● V680S-HMD63-EIP and V680-D1KP66T

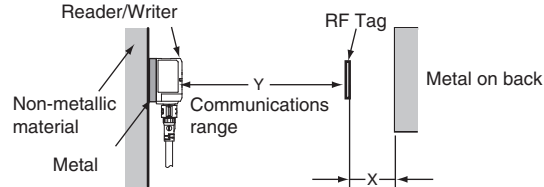
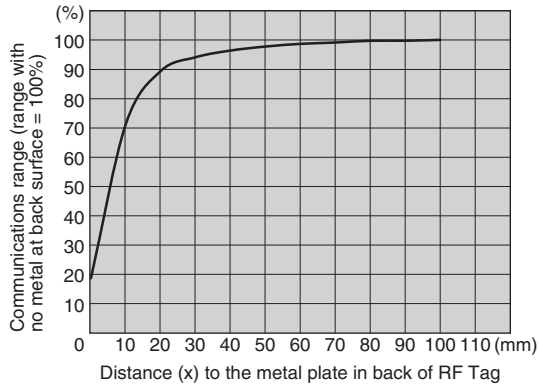

● V680S-HMD64-EIP and V680-D1KP66T

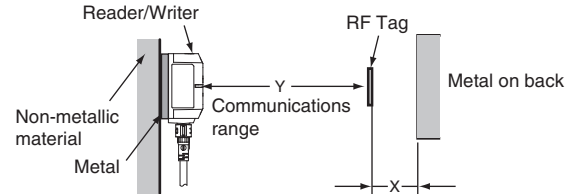
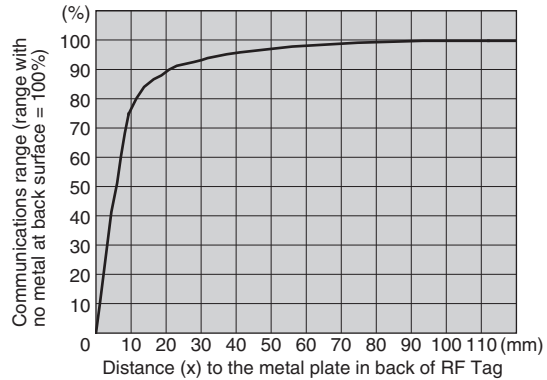

● V680S-HMD66-EIP and V680-D1KP66T

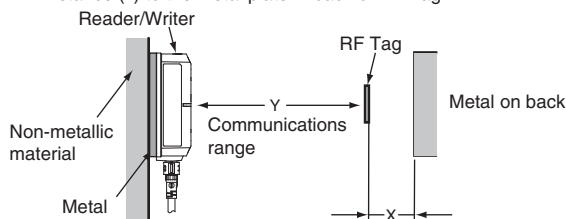
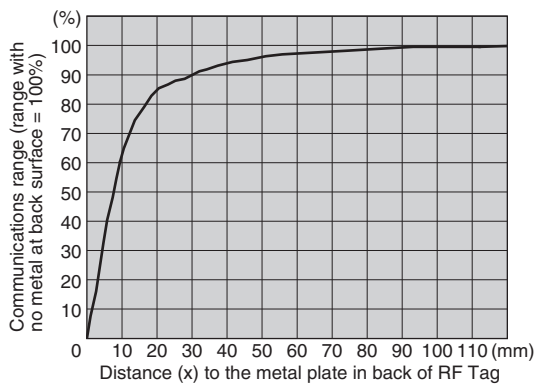

■ **Mutual Interference of RF Tags**

If you use more than one RF Tag, separate them by at least the interval shown below to prevent malfunctions due to mutual interference.

If the distance between the RF tags is too short, read / write distance will be reduced.

■ **V680S-HMD63-EIP Reader/Writer**

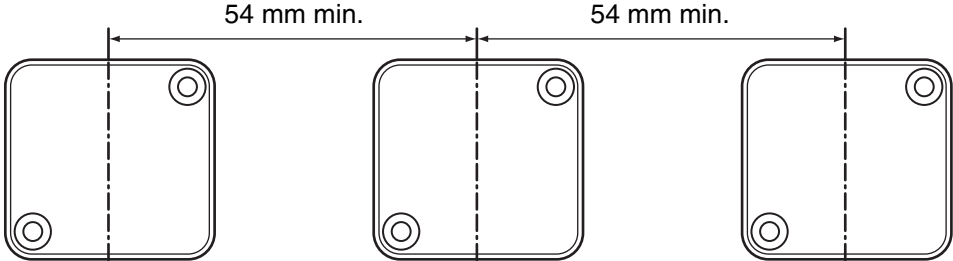

■ **V680S-HMD64-EIP Reader/Writer**

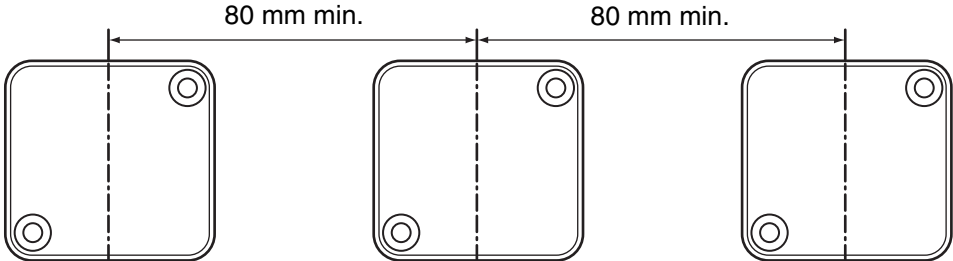

■ **V680S-HMD66-EIP Reader/Writer**

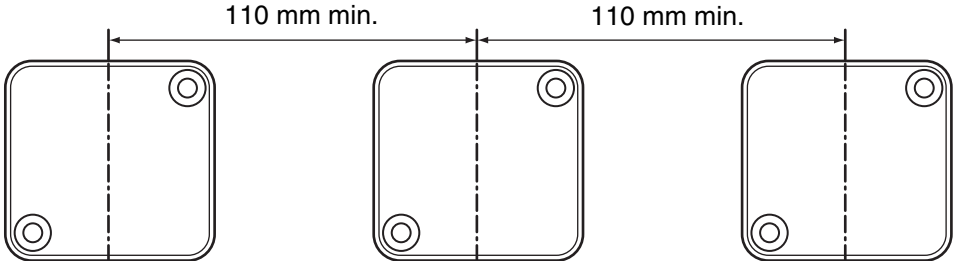

■ Influence of Inclination

Install the Reader/Writer and RF Tags so that the Reader/Writer and RF Tags are as parallel to each other as possible.

Communications will be possible even if the Reader/Writer and RF Tags are not parallel to each other; however, the communications range is affected by the inclination between them as shown in the following graphs.

■ Rates of Change in Communications Range for Inclination of V680-D1KP66T

	RF Tag inclination (θ°)									
	0	10	20	30	40	50	60	70	80	90
V680S-HMD63-EIP and V680-D1KP66T-SP	0%	-1%	-2%	-4%	-8%	-13%	-19%	-29%	-44%	---
V680S-HMD64-EIP and V680-D1KP66T	0%	-1%	-3%	-5%	-9%	-14%	-21%	-32%	-48%	---
V680S-HMD66-EIP and V680-D1KP66T	0%	-1%	-3%	-6%	-10%	-17%	-27%	-41%	-62%	---

■ Measurement Conditions

“ V680S-HMD63-EIP and V680-D1KP66T

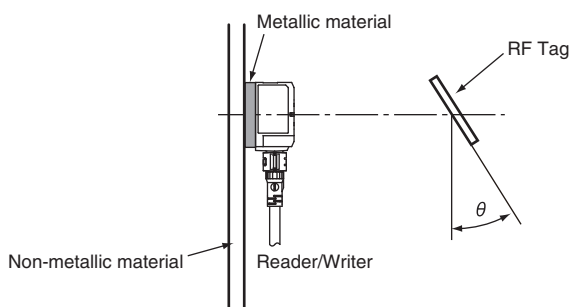

“ V680S-HMD64-EIP and V680-D1KP66T

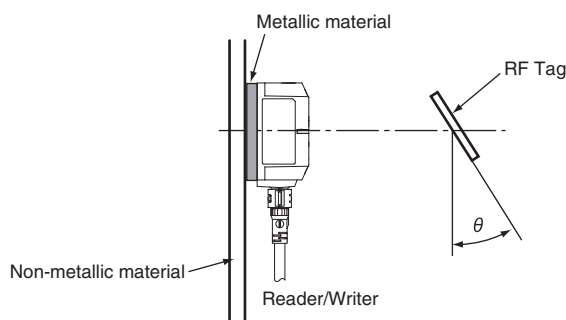

“ V680S-HMD66-EIP and V680-D1KP66T

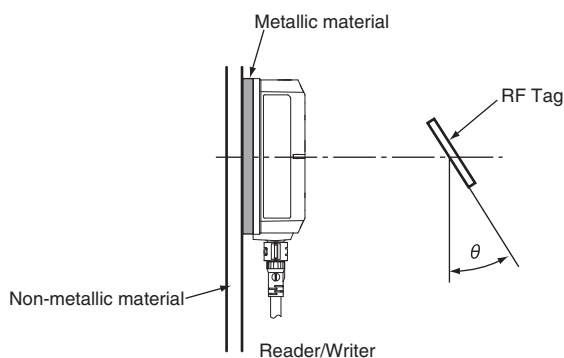

V680-D1KP66MT

■ Influence of Surrounding Metal

The V680-D1KP66MT can be surface-mounted or it can be embedded in metal. However, do not allow the height of the metal to exceed the height of the V680-D1KP66MT.

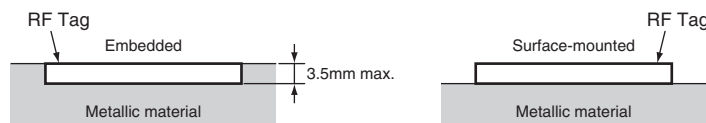

● V680S-HMD63-EIP and V680-D1KP66MT

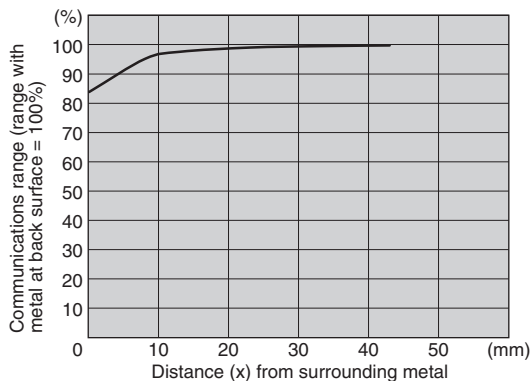

● V680S-HMD64-EIP and V680-D1KP66MT

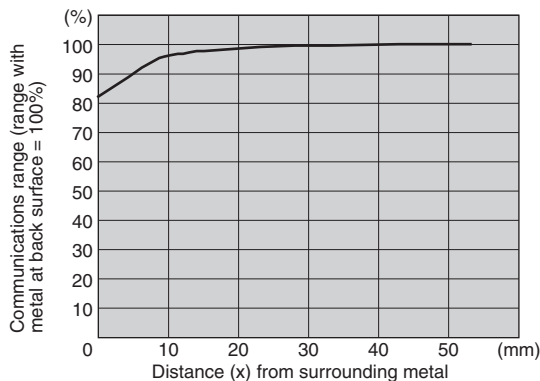

● V680S-HMD66-EIP and V680-D1KP66MT

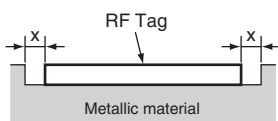
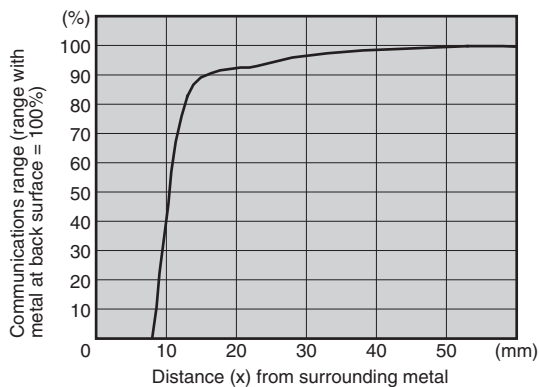

■ Mutual Interference of RF Tags

If you use more than one RF Tag, separate them by at least the interval shown below to prevent malfunctions due to mutual interference.

If the distance between the RF tags is too short, read / write distance will be reduced.

■ V680S-HMD63-EIP Reader/Writer

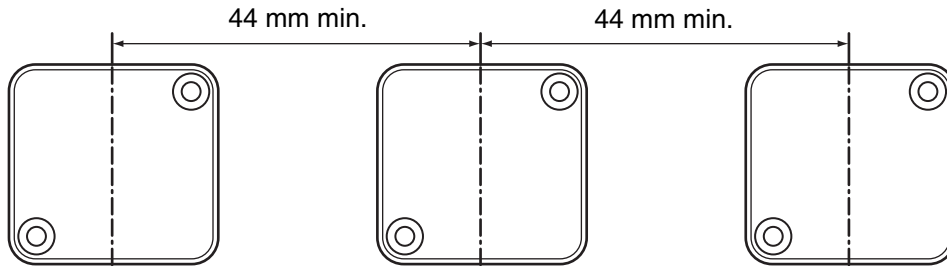

■ V680S-HMD64-EIP Reader/Writer

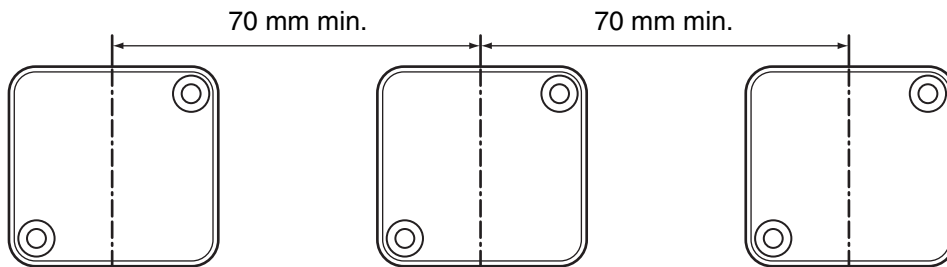

■ V680S-HMD66-EIP Reader/Writer

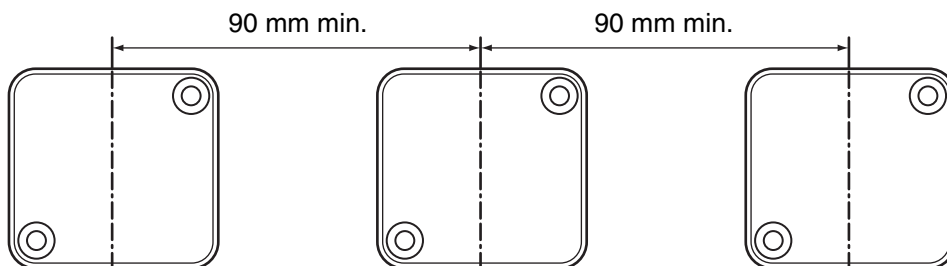

■ Influence of Inclination

Install the Reader/Writer and RF Tags so that the Reader/Writer and RF Tags are as parallel to each other as possible.

Communications will be possible even if the Reader/Writer and RF Tags are not parallel to each other; however, the communications range is affected by the inclination between them as shown in the following graphs.

■ Rates of Change in Communications Range for Inclination of V680-D1KP66MT

	RF Tag inclination (θ°)									
	0	10	20	30	40	50	60	70	80	90
V680S-HMD63-EIP and V680-D1KP66MT (Metal at back surface: Steel)	0%	-1%	-6%	-9%	-15%	-23%	-36%	-67%	---	---
V680S-HMD64-EIP and V680-D1KP66MT (Metal at back surface: Steel)	0%	0%	-2%	-5%	-10%	-18%	-31%	-59%	---	---
V680S-HMD66-EIP and V680-D1KP66MT (Metal at back surface: Steel)	0%	0%	-3%	-7%	-16%	-28%	-49%	---	---	---

■ Measurement Conditions

” V680S-HMD63-EIP and V680-D1KP66MT
(Metal at Back Surface: Steel)

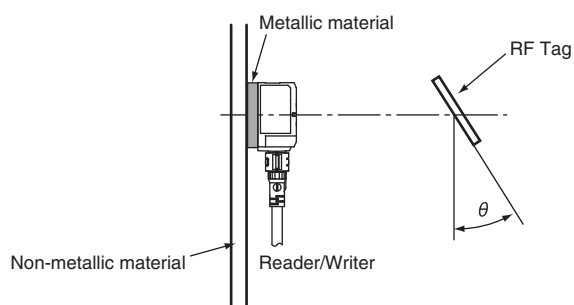

” V680S-HMD64-EIP and V680-D1KP66MT
(Metal at Back Surface: Steel)

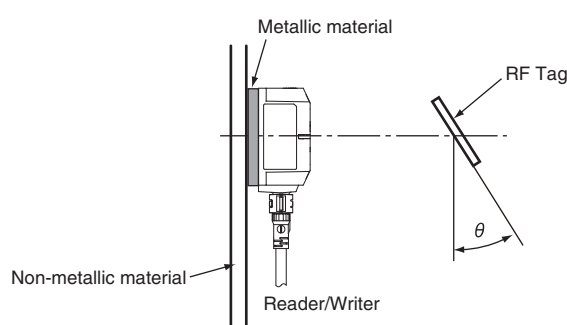

” V680S-HMD66-EIP and V680-D1KP66MT
(Metal at Back Surface: Steel)

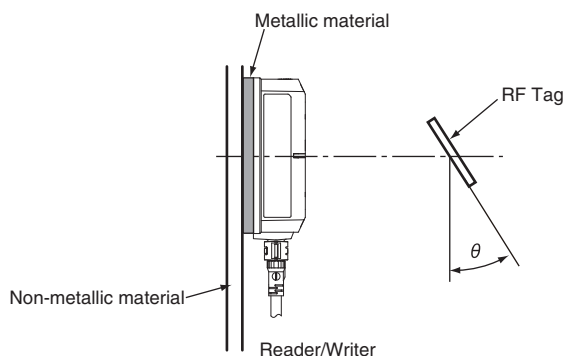

V680-D1KP66T-SP

■ Influence of Metal at Back Surface

The communications range will decrease if there is metal at the back of the V680-D1KP66T-SP RF Tag. If the RF Tag is mounted on metallic material, use a non-metallic spacer (e.g., plastic or resin). The following graphs show the relationship between the distance from the RF Tag to the metallic surface and the communications range.

● V680S-HMD63-EIP and V680-D1KP66T-SP

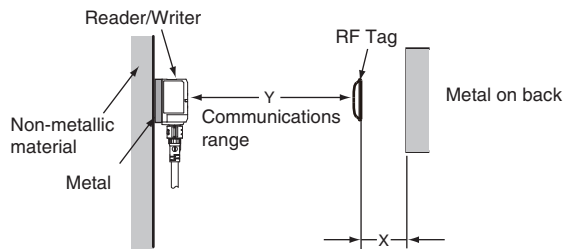
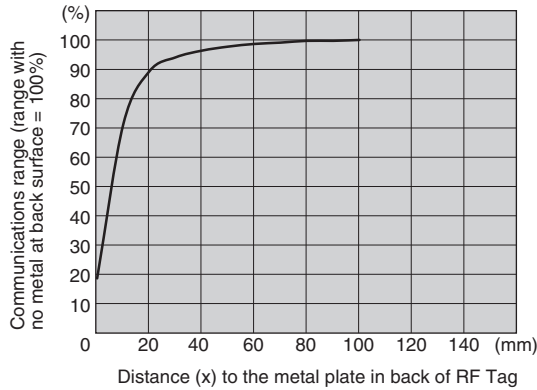

● V680S-HMD64-EIP and V680-D1KP66T-SP

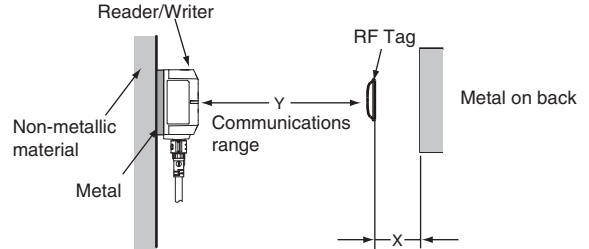
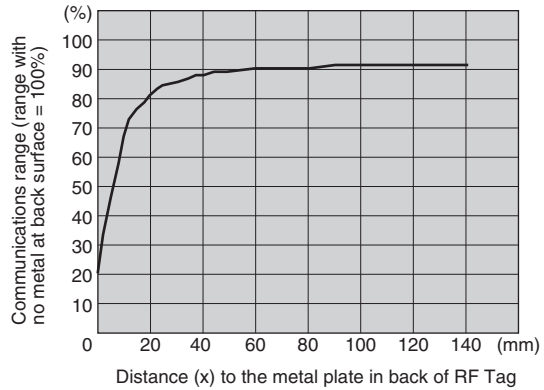

● V680S-HMD66-EIP and V680-D1KP66T-SP

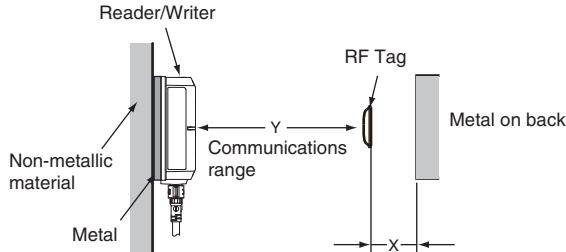
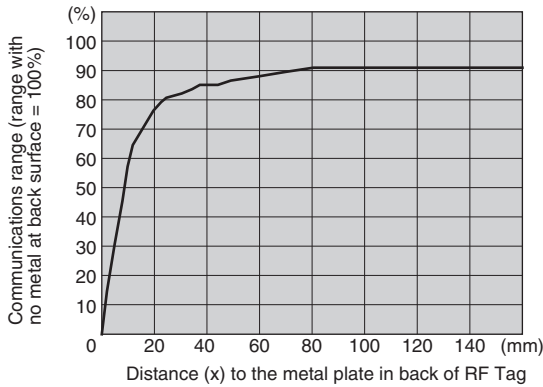

■ **Mutual Interference of RF Tags**

If you use more than one RF Tag, separate them by at least the interval shown below to prevent malfunctions due to mutual interference.

If the distance between the RF tags is too short, read / write distance will be reduced.

■ **V680S-HMD63-EIP Reader/Writer**

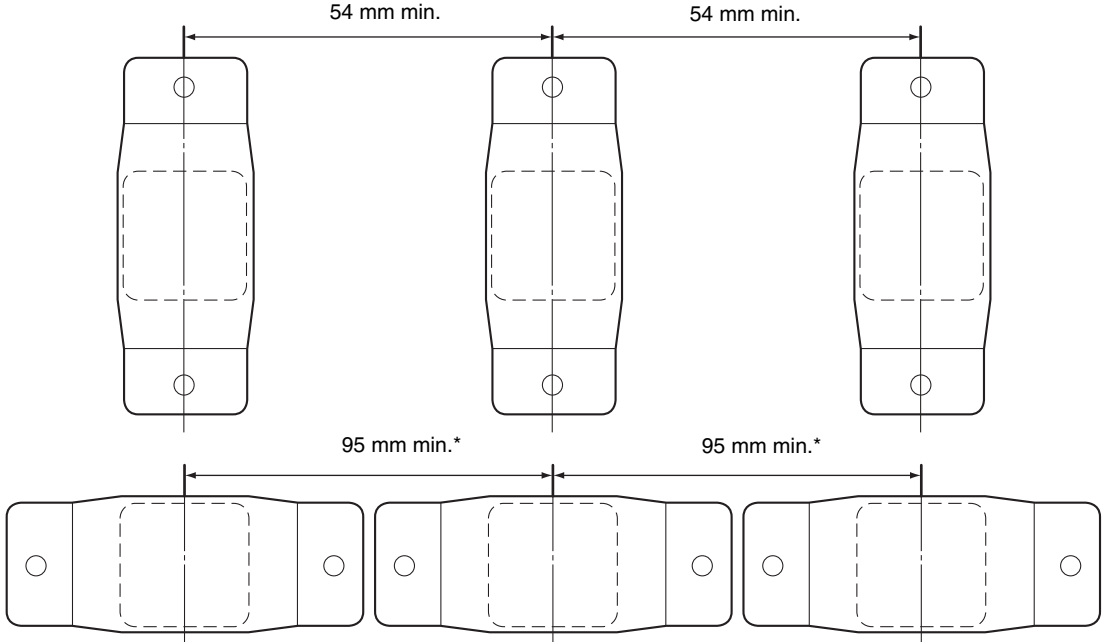

■ **V680S-HMD64-EIP Reader/Writer**

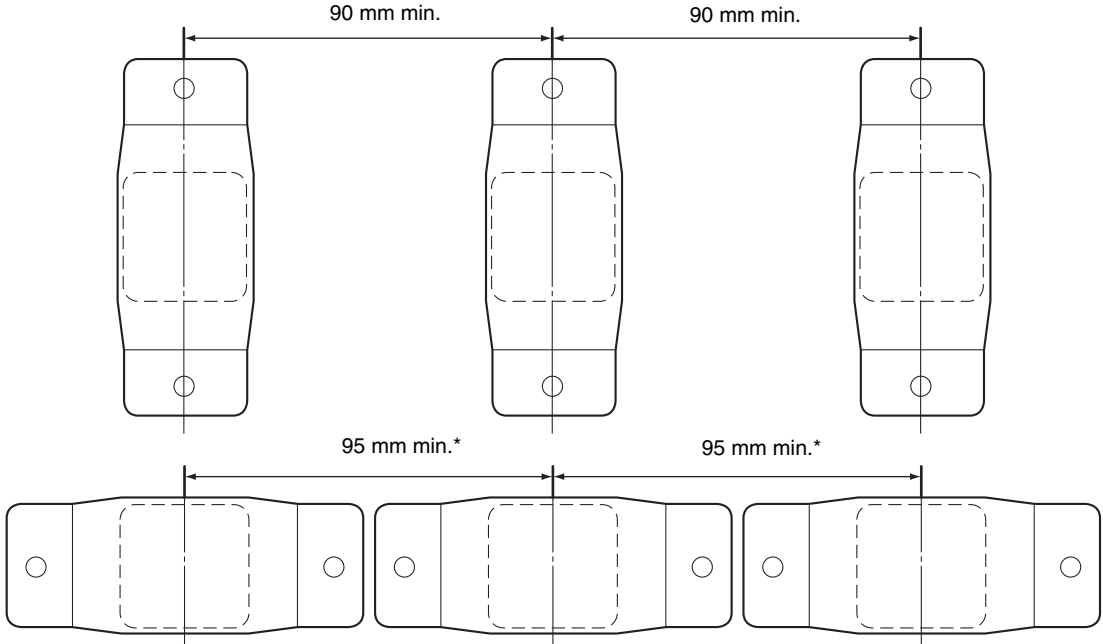

* This is required for the V680-D1KP66T-SP exterior dimension (Length: 95 mm).

V680S-HMD66-EIP Reader/Writer

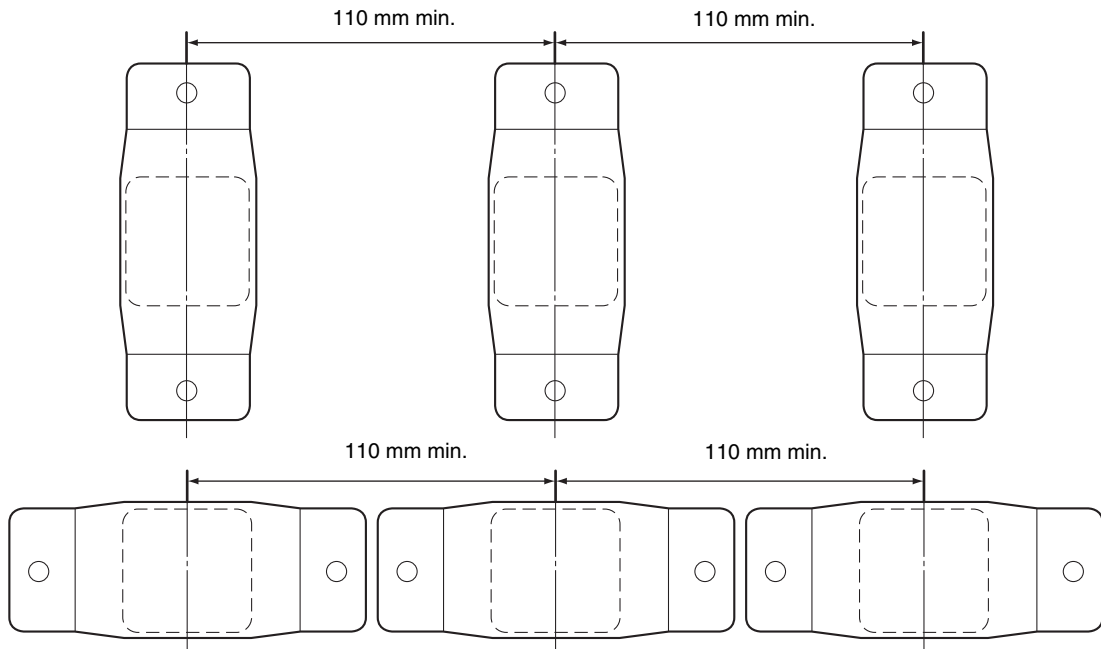

■ Influence of Inclination

Install the Reader/Writer and RF Tags so that the Reader/Writer and RF Tags are as parallel to each other as possible.

Communications will be possible even if the Reader/Writer and RF Tags are not parallel to each other; however, the communications range is affected by the inclination between them as shown in the following graphs.

■ Rates of Change in Communications Range for Inclination of V680-D1KP66T-SP

	RF Tag inclination (θ°)									
	0	10	20	30	40	50	60	70	80	90
V680S-HMD63-EIP and V680-D1KP66T-SP	0%	-1%	-2%	-4%	-8%	-13%	-19%	-29%	-44%	---
V680S-HMD64-EIP and V680-D1KP66T-SP	0%	-1%	-3%	-5%	-9%	-14%	-21%	-32%	-48%	---
V680S-HMD66-EIP and V680-D1KP66T-SP	0%	-1%	-3%	-6%	-10%	-17%	-27%	-41%	-62%	---

■ Measurement Conditions

" V680S-HMD63-EIP and V680-D1KP66T-SP

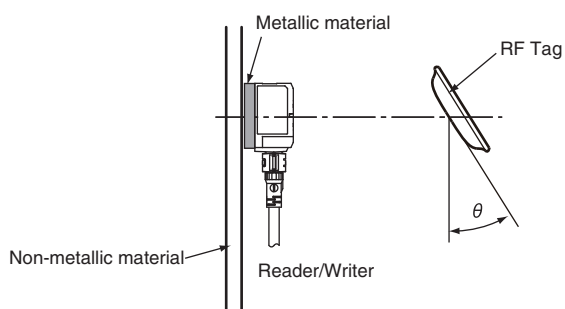

" V680S-HMD64-EIP and V680-D1KP66T-SP

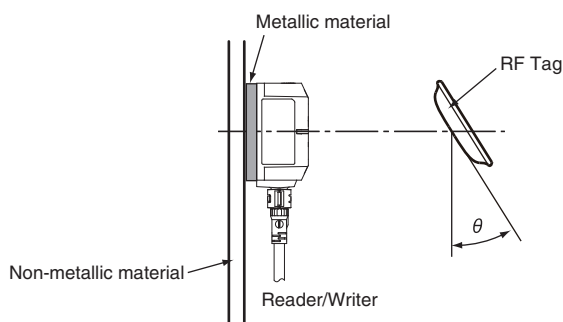

" V680S-HMD66-EIP and V680-D1KP66T-SP

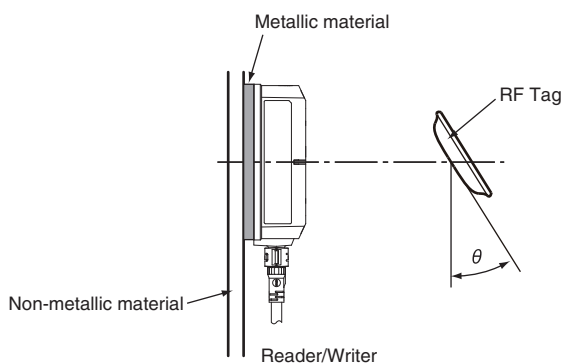

V680-D1KP58HTN

■ Influence of Metal at Back Surface

You must consider the influence of the mounting location when mounting RF Tags.

The communications range of an RF Tag may be reduced by the influence of the surrounding objects. The amount that the communications range decreases will depend on the materials and shapes of the surrounding objects. As reference data, this section shows the influence of metal at the back surface of an RF Tag.

■ Influence of Metal Objects

The following figure shows the percentage of decrease in the communications range when there is a metal object at the back surface of an RF Tag.

The X axis gives the distance between the RF Tag and a metal plate. The Y axis shows the relative communications range taking the communications range with no metal plate as 100% (i.e., it shows the percentage of decrease in the communications range).

● V680S-HMD64-EIP and V680-D1KP58HTN

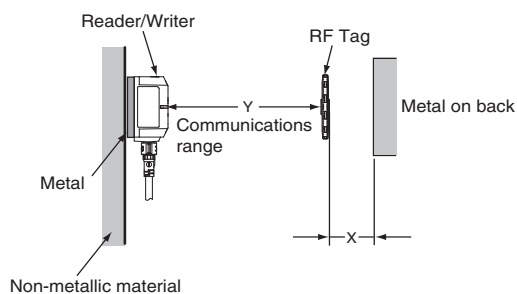
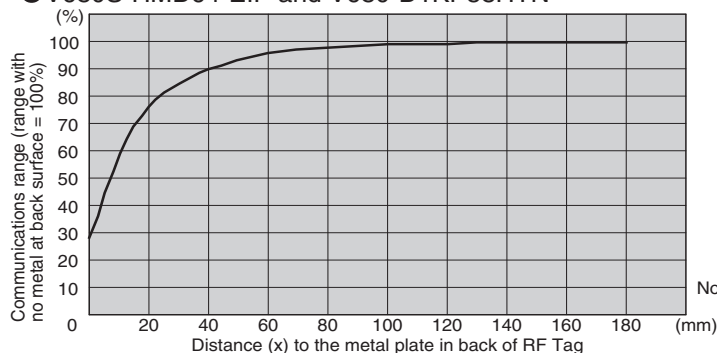

● V680S-HMD66-EIP and V680-D1KP58HTN

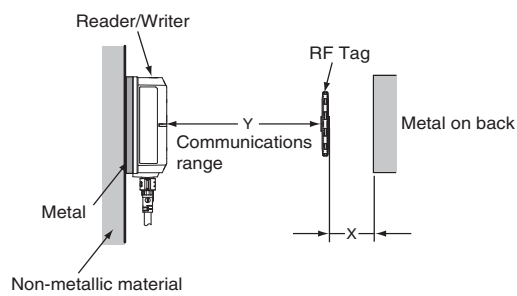
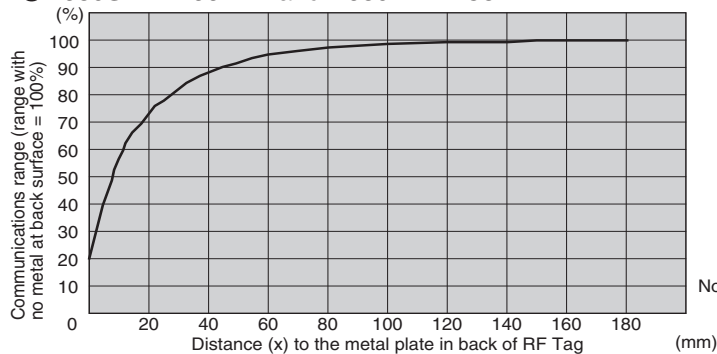

Material: Steel (thickness: 1.5 mm)

Shape: 295 × 295 mm

■ Mutual Interference of RF Tags

If you use more than one RF Tag, separate them by at least the interval shown below to prevent malfunctions due to mutual interference.

If the distance between the RF tags is too short, read / write distance will be reduced.

■ V680S-HMD64-EIP Reader/Writer

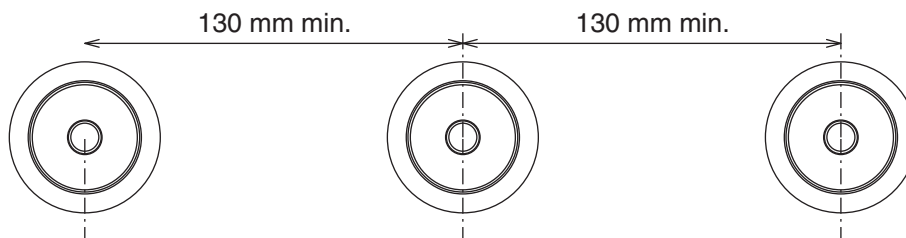

■ V680S-HMD66-EIP Reader/Writer

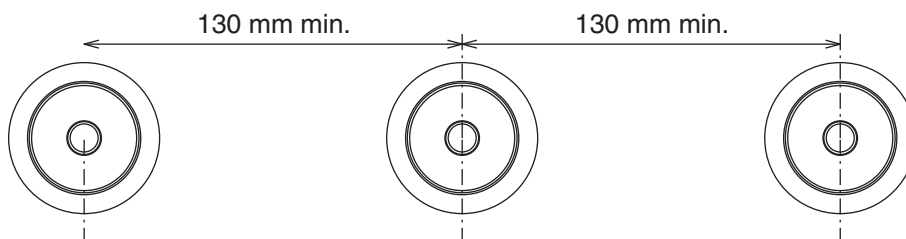

■ Influence of Inclination

The maximum communications range is achieved when the RF Tags are mounted so that the surfaces of the RF Tags are parallel with the surface of the Reader/Writer. If the RF Tags are mounted at an angle, the communications range will decrease. You must consider the influence of the inclination of the RF Tags when mounting RF Tags.

As reference data, this section shows the decrease in the communications range due to RF Tag inclination.

The X axis gives the angle with 0° which indicates that the RF Tag and Reader/Writer surfaces are parallel to each other. The Y axis shows the relative communications range taking the communications range at 0° as 100% (i.e., it shows the percentage of decrease in the communications range).

■ Rates of Change in Communications Range for Inclination of V680-D1KP58HTN

	RF Tag inclination (θ°)									
	0	10	20	30	40	50	60	70	80	90
V680S-HMD64-EIP and V680-D1KP58HTN	0%	-1%	-3%	-5%	-8%	-14%	-22%	-32%	-35%	---
V680S-HMD66-EIP and V680-D1KP58HTN	0%	-1%	-2%	-4%	-7%	-11%	-17%	-27%	-44%	---

■ Measurement Conditions

” V680S-HMD64-EIP and V680-D1KP58HTN

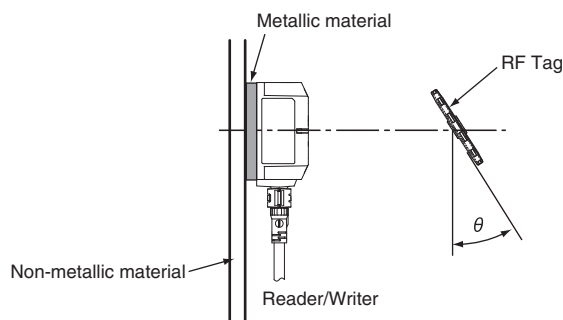

” V680S-HMD66-EIP and V680-D1KP58HTN

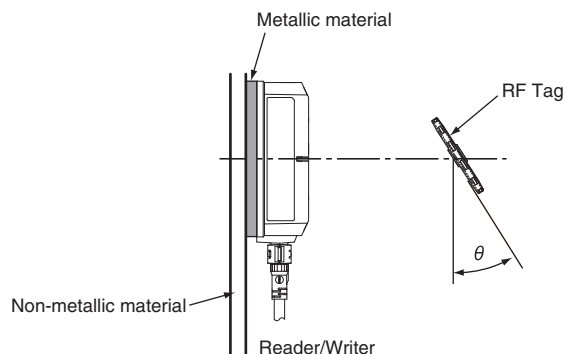

V680S-D2KF67

■ Influence of Metal at Back Surface of RF Tags

The communications range will decrease if there is metal at the back of the V680S-D2KF67 RF Tag. If the RF Tag is mounted on metallic material, use a non-metallic spacer (e.g., plastic or resin). The following graphs show the relationship between the distance from the RF Tag to the metallic surface and the communications range.

● V680S-HMD63-EIP and V680S-D2KF67

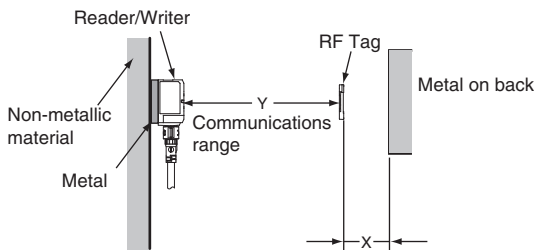
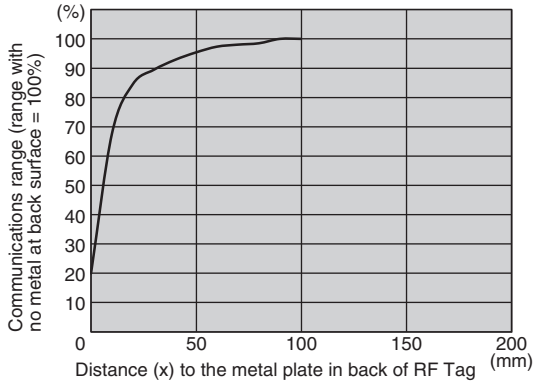

● V680S-HMD64-EIP and V680S-D2KF67

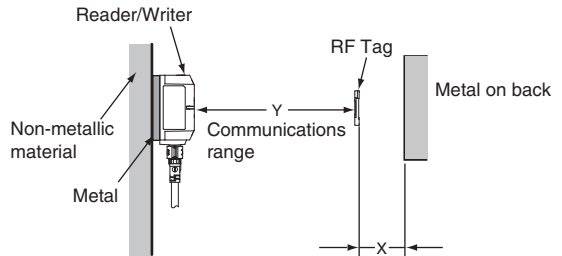
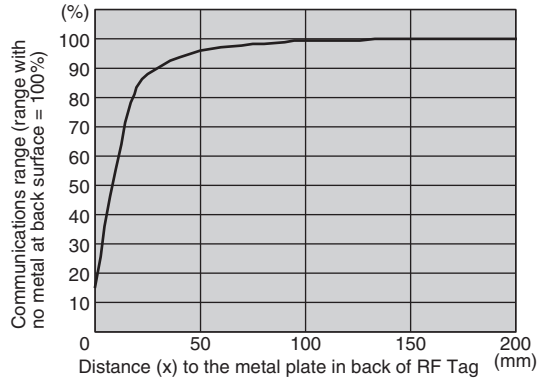

● V680S-HMD66-EIP and V680S-D2KF67

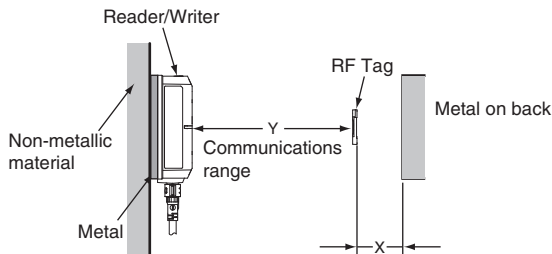
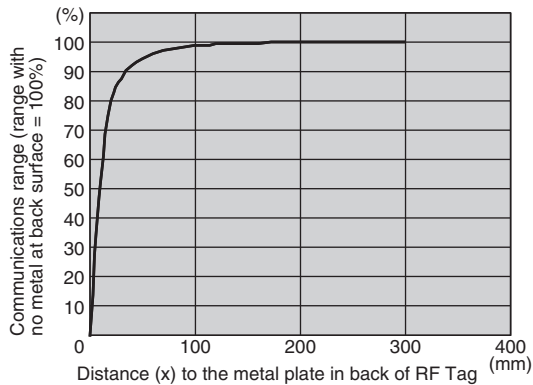

■ **Mutual Interference of RF Tags**

If you use more than one RF Tag, separate them by at least the interval shown below to prevent malfunctions due to mutual interference.

If the distance between the RF tags is too short, read / write distance will be reduced.

■ **V680S-HMD63-EIP Reader/Writer**

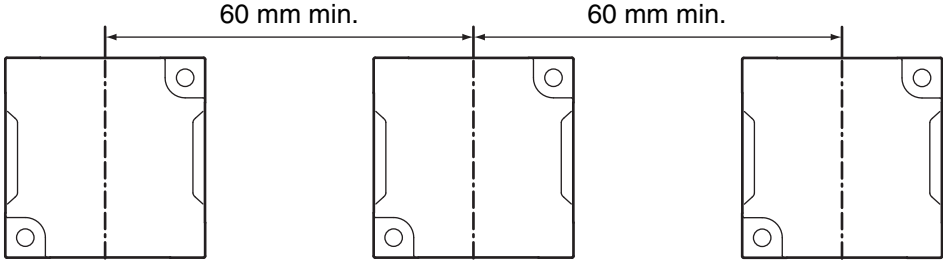

■ **V680S-HMD64-EIP Reader/Writer**

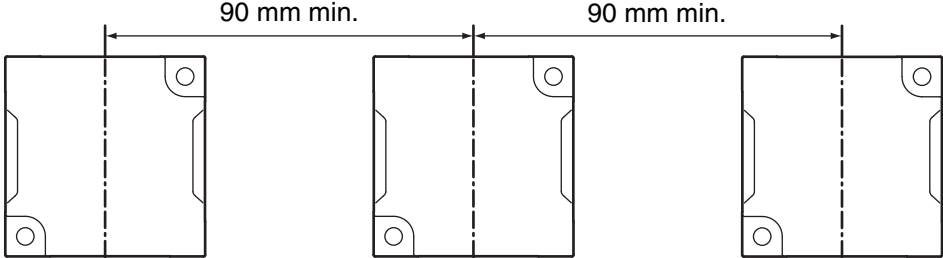

■ **V680S-HMD66-EIP Reader/Writer**

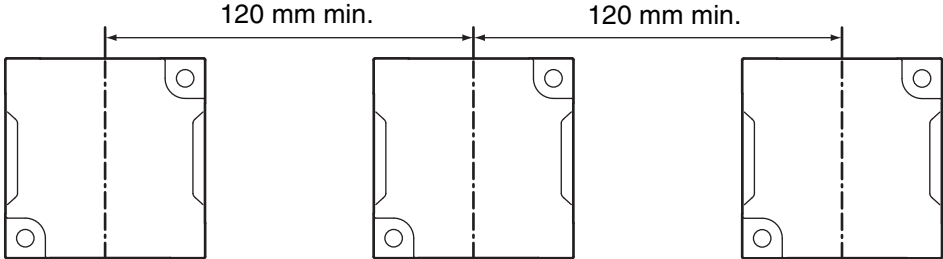

■ Influence of Inclination

Install the Reader/Writer and RF Tags so that the Reader/Writer and RF Tags are as parallel to each other as possible.

Communications will be possible even if the Reader/Writer and RF Tags are not parallel to each other; however, the communications range is affected by the inclination between them as shown in the following graphs.

■ Rates of Change in Communications Range for Inclination of V680S-D2KF67

	RF Tag inclination (θ°)									
	0	10	20	30	40	50	60	70	80	90
V680S-HMD63-EIP and V680S-D2KF67	0%	-1%	-2%	-4%	-8%	-13%	-20%	-29%	-44%	---
V680S-HMD64-EIP and V680S-D2KF67	0%	-1%	-3%	-5%	-8%	-13%	-19%	-27%	-38%	---
V680S-HMD66-EIP and V680S-D2KF67	0%	-1%	-2%	-4%	-8%	-13%	-19%	-29%	-43%	---

■ Measurement Conditions

“ V680S-HMD63-EIP and V680S-D2KF67

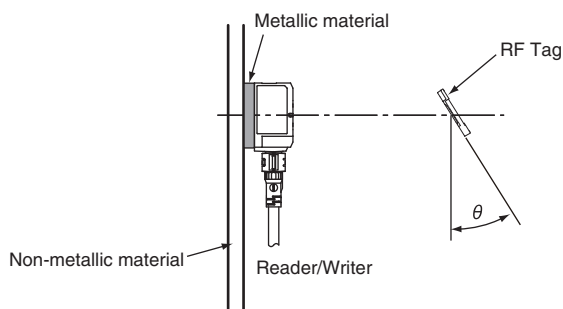

“ V680S-HMD64-EIP and V680S-D2KF67

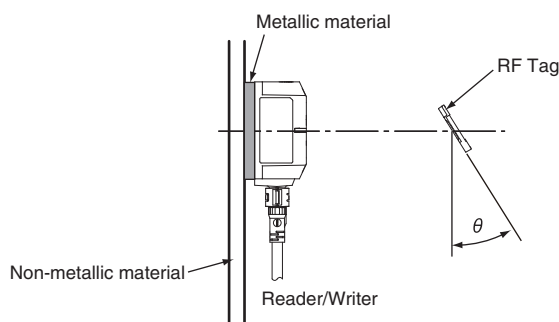

“ V680S-HMD66-EIP and V680S-D2KF67

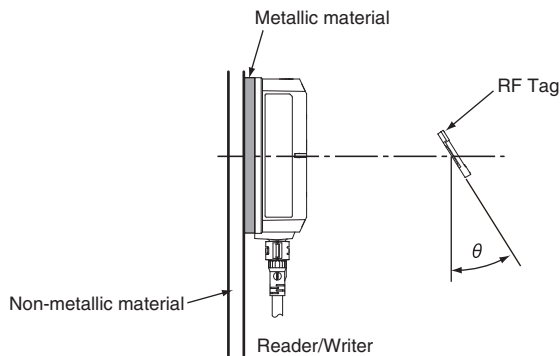

V680S-D2KF67M

■ Influence of Surrounding Metal

The V680S-D2KF67M can be surface-mounted or it can be embedded in metal. However, do not allow the height of the metal to exceed the height of the V680S-D2KF67M.

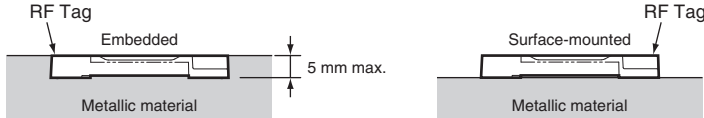

● V680S-HMD63-EIP and V680S-D2KF67M

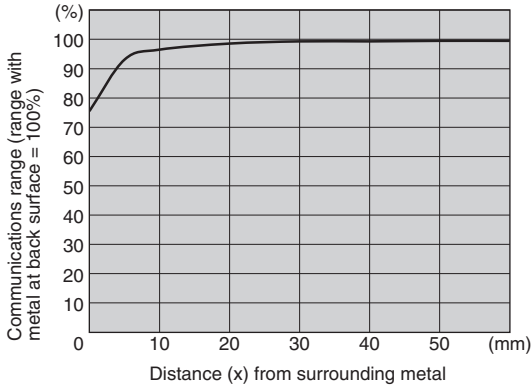

● V680S-HMD64-EIP and V680S-D2KF67M

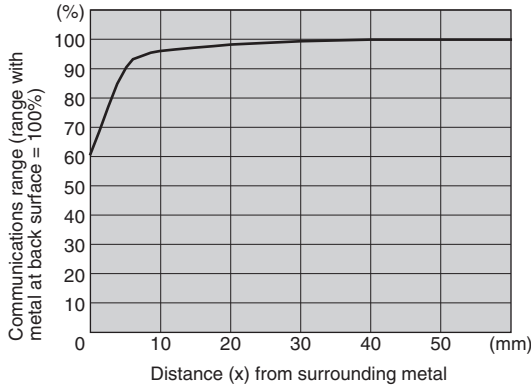

● V680S-HMD66-EIP and V680S-D2KF67M

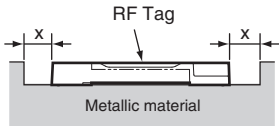
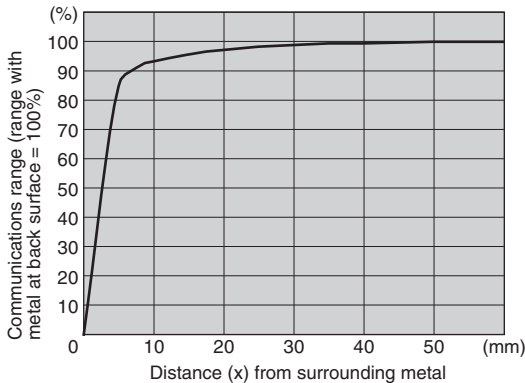

■ Mutual Interference of RF Tags

If you use more than one RF Tag, separate them by at least the interval shown below to prevent malfunctions due to mutual interference.

If the distance between the RF tags is too short, read / write distance will be reduced.

■ V680S-HMD63-EIP Reader/Writer

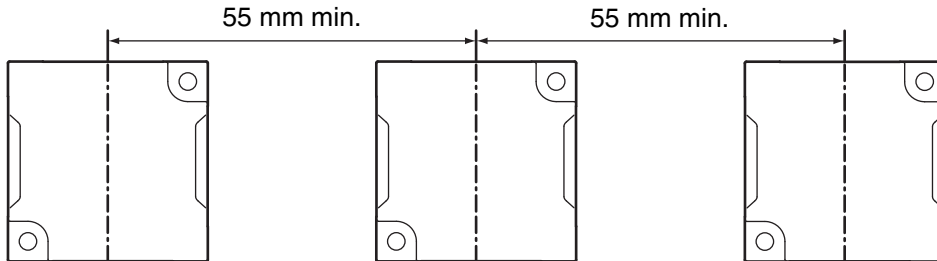

■ V680S-HMD64-EIP Reader/Writer

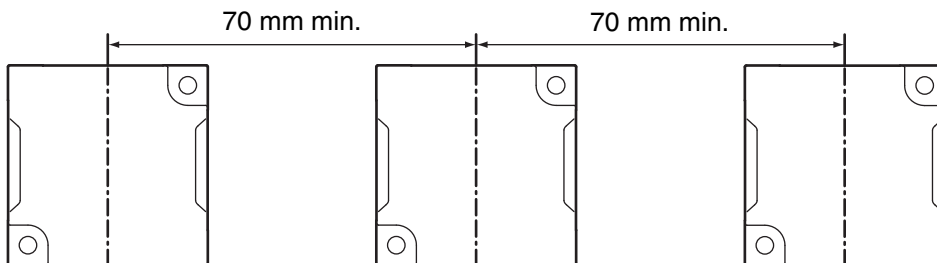

■ V680S-HMD66-EIP Reader/Writer

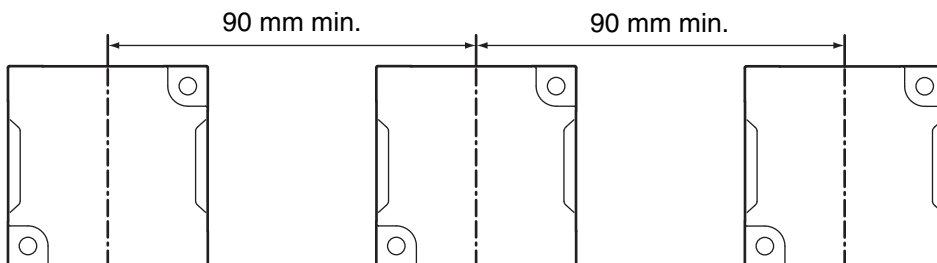

■ Influence of Inclination

Install the Reader/Writer and RF Tags so that the Reader/Writer and RF Tags are as parallel to each other as possible.

Communications will be possible even if the Reader/Writer and RF Tags are not parallel to each other; however, the communications range is affected by the inclination between them as shown in the following graphs.

■ Rates of Change in Communications Range for Inclination of V680S-D2KF67M

	RF Tag inclination (θ°)									
	0	10	20	30	40	50	60	70	80	90
V680S-HMD63-EIP and V680S-D2KF67M (Metal at back surface: Steel)	0%	-1%	-4%	-8%	-15%	-25%	-50%	---	---	---
V680S-HMD64-EIP and V680S-D2KF67M (Metal at back surface: Steel)	0%	-1%	-3%	-7%	-12%	-21%	-37%	---	---	---
V680S-HMD66-EIP and V680S-D2KF67M (Metal at back surface: Steel)	0%	-1%	-4%	-9%	-18%	-33%	---	---	---	---

■ Measurement Conditions

” V680S-HMD63-EIP and V680S-D2KF67M
(Metal at Back Surface: Steel)

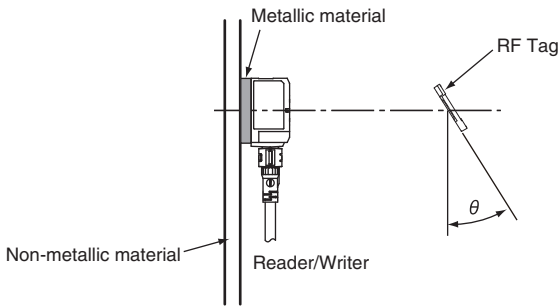

” V680S-HMD64-EIP and V680S-D2KF67M
(Metal at Back Surface: Steel)

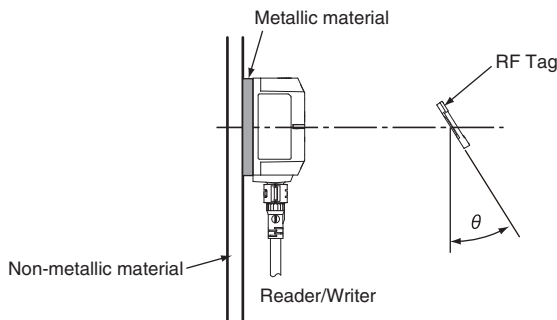

” V680S-HMD66-EIP and V680S-D2KF67M
(Metal at Back Surface: Steel)

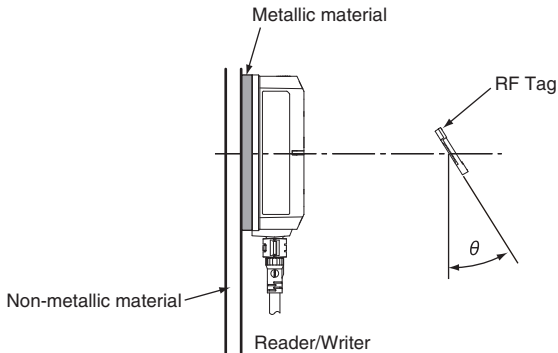

V680S-D8KF67

■ Influence of Metal at Back Surface of RF Tags

The communications range will decrease if there is metal at the back of the V680S-D8KF67 RF Tag. If the RF Tag is mounted on metallic material, use a non-metallic spacer (e.g., plastic or resin). The following graphs show the relationship between the distance from the RF Tag to the metallic surface and the communications range.

● V680S-HMD63-EIP and V680S-D8KF67

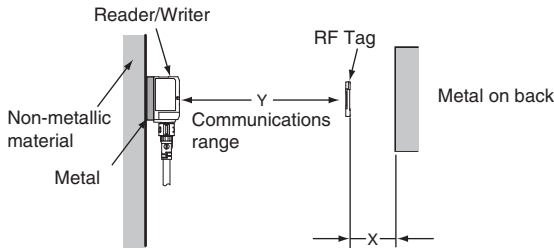
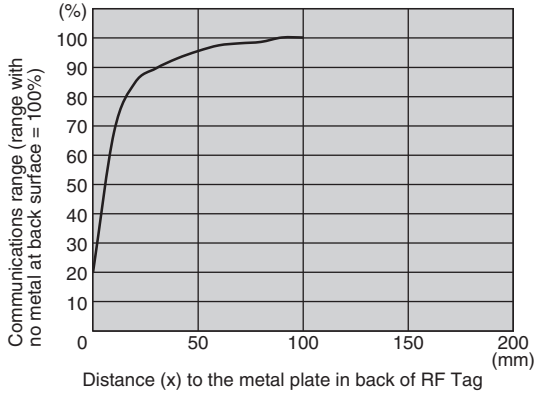

● V680S-HMD64-EIP and V680S-D8KF67

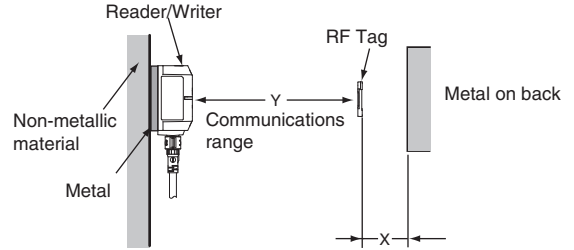
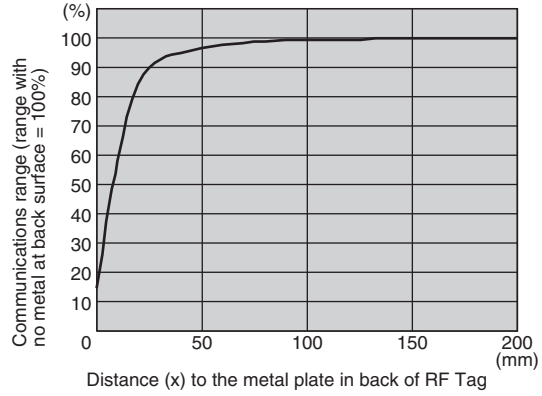

● V680S-HMD66-EIP and V680S-D8KF67

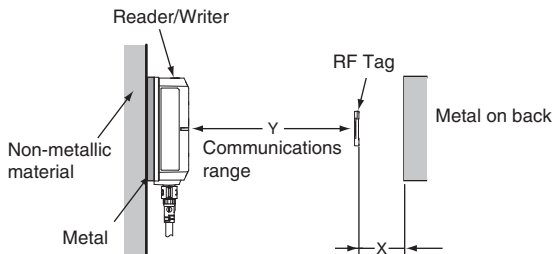
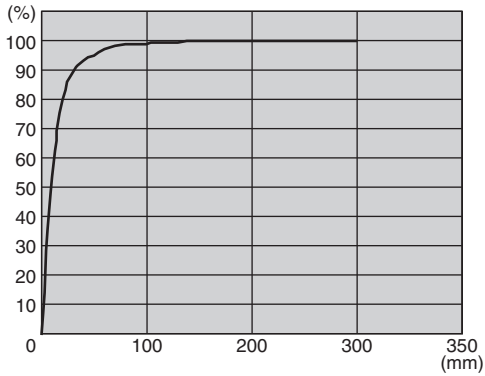

■ **Mutual Interference of RF Tags**

If you use more than one RF Tag, separate them by at least the interval shown below to prevent malfunctions due to mutual interference.

If the distance between the RF tags is too short, read / write distance will be reduced.

■ **V680S-HMD63-EIP Reader/Writer**

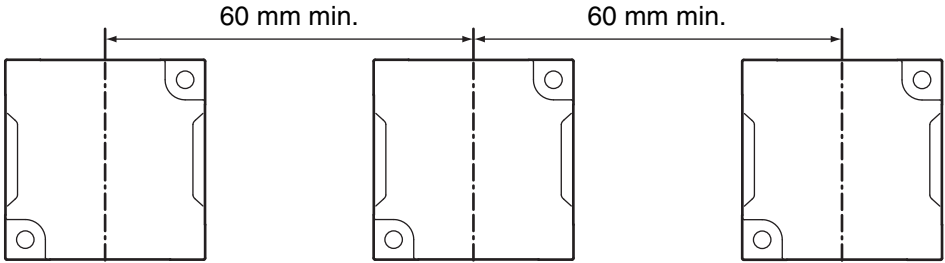

■ **V680S-HMD64-EIP Reader/Writer**

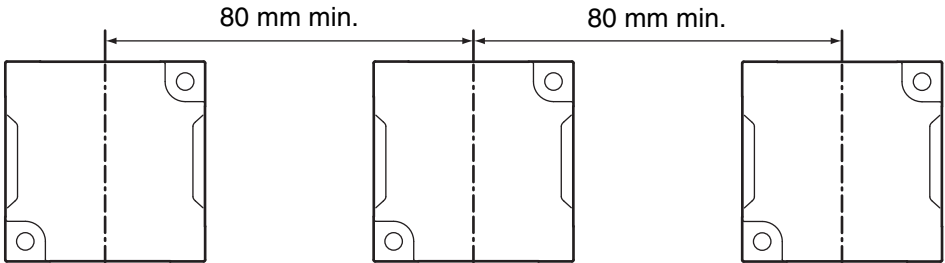

■ **V680S-HMD66-EIP Reader/Writer**

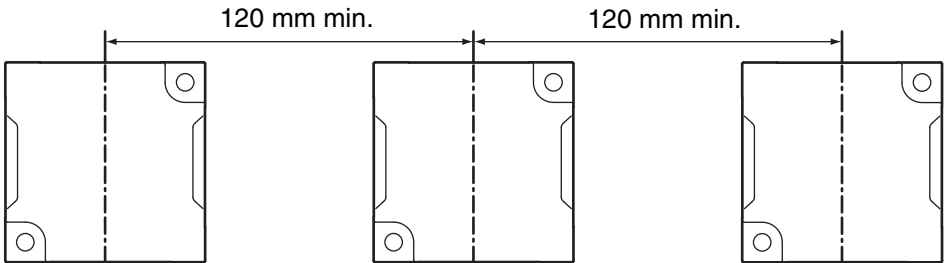

■ Influence of Inclination

Install the Reader/Writer and RF Tags so that the Reader/Writer and RF Tags are as parallel to each other as possible.

Communications will be possible even if the Reader/Writer and RF Tags are not parallel to each other; however, the communications range is affected by the inclination between them as shown in the following graphs.

■ Rates of Change in Communications Range for Inclination of V680S-D2KF67

	RF Tag inclination (θ°)									
	0	10	20	30	40	50	60	70	80	90
V680S-HMD63-EIP and V680S-D8KF67	0%	-1%	-2%	-5%	-8%	-13%	-20%	-30%	-45%	---
V680S-HMD64-EIP and V680S-D8KF67	0%	-1%	-2%	-4%	-6%	-10%	-17%	-24%	-36%	---
V680S-HMD66-EIP and V680S-D8KF67	0%	-1%	-2%	-4%	-7%	-12%	-19%	-28%	-42%	---

■ Measurement Conditions

“ V680S-HMD63-EIP and V680S-D8KF67

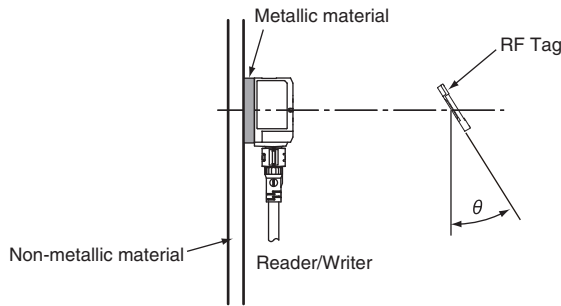

“ V680S-HMD64-EIP and V680S-D8KF67

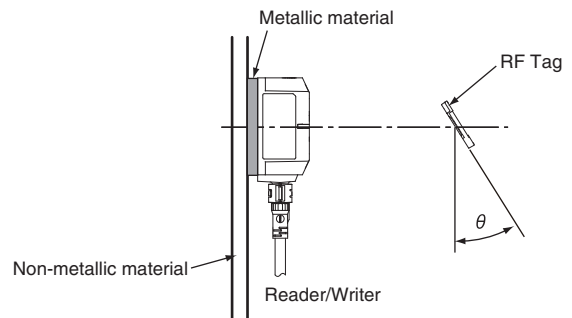

“ V680S-HMD66-EIP and V680S-D8KF67

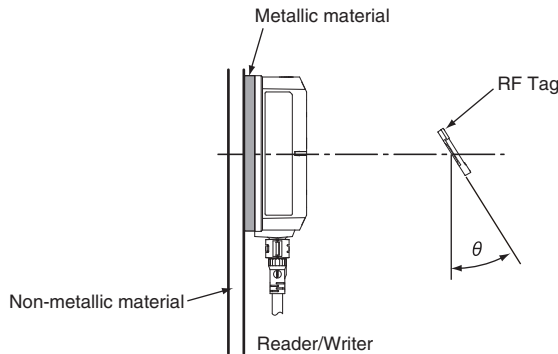

V680S-D8KF67M

■ Influence of Surrounding Metal

The V680S-D8KF67M can be surface-mounted or it can be embedded in metal. However, do not allow the height of the metal to exceed the height of the V680S-D8KF67M.

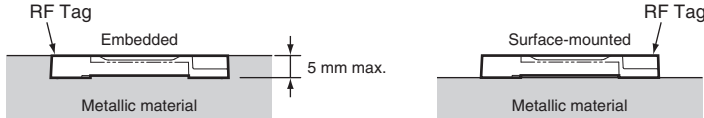

● V680S-HMD63-EIP and V680S-D8KF67M

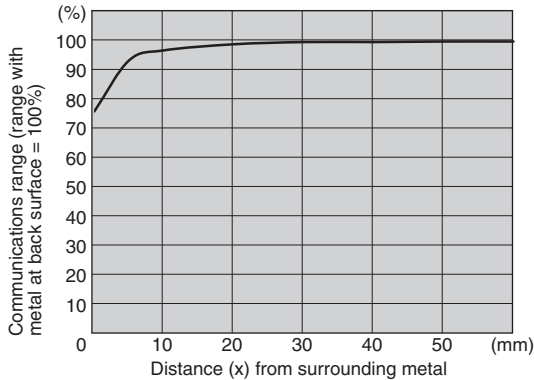

● V680S-HMD64-EIP and V680S-D8KF67M

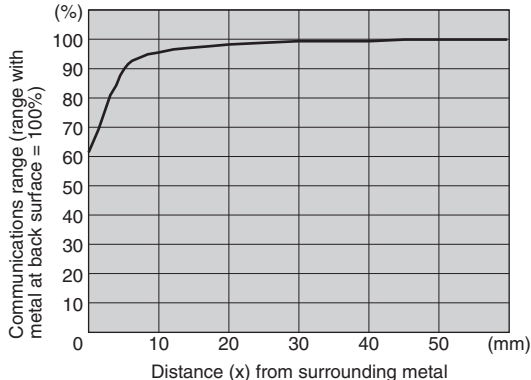

● V680S-HMD66-EIP and V680S-D8KF67M

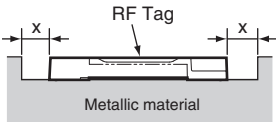
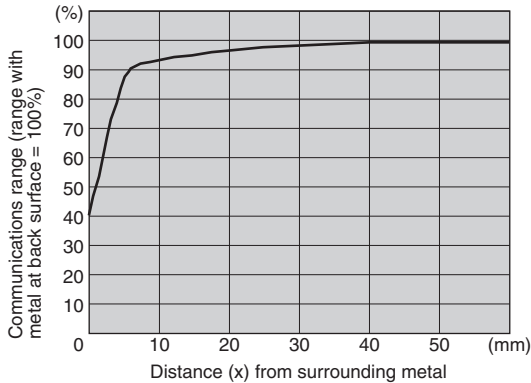

■ Mutual Interference of RF Tags

If you use more than one RF Tag, separate them by at least the interval shown below to prevent malfunctions due to mutual interference.

If the distance between the RF tags is too short, read / write distance will be reduced.

■ V680S-HMD63-EIP Reader/Writer

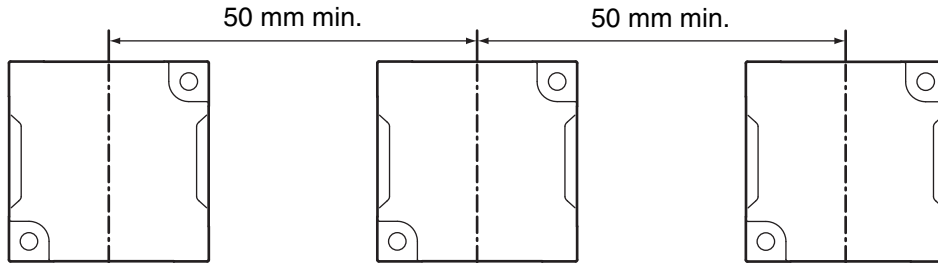

■ V680S-HMD64-EIP Reader/Writer

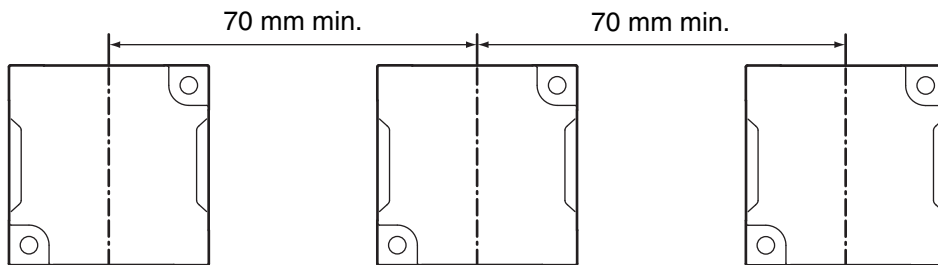

■ V680S-HMD66-EIP Reader/Writer

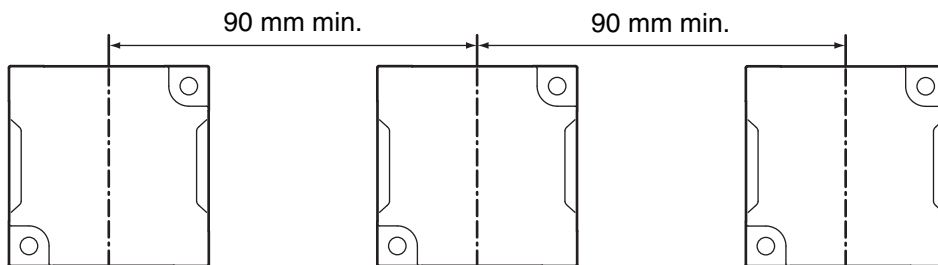

■ Influence of Inclination

Install the Reader/Writer and RF Tags so that the Reader/Writer and RF Tags are as parallel to each other as possible.

Communications will be possible even if the Reader/Writer and RF Tags are not parallel to each other; however, the communications range is affected by the inclination between them as shown in the following graphs.

■ Rates of Change in Communications Range for Inclination of V680S-D8KF67M

	RF Tag inclination (θ°)									
	0	10	20	30	40	50	60	70	80	90
V680S-HMD63-EIP and V680S-D8KF67M (Metal at back surface: Steel)	0%	-1%	-3%	-7%	-13%	-24%	-47%	---	---	---
V680S-HMD64-EIP and V680S-D8KF67M (Metal at back surface: Steel)	0%	-1%	-3%	-7%	-13%	-22%	-38%	---	---	---
V680S-HMD66-EIP and V680S-D8KF67M (Metal at back surface: Steel)	0%	-1%	-4%	-10%	-20%	-39%	---	---	---	---

■ Measurement Conditions

” V680S-HMD63-EIP and V680S-D8KF67M
(Metal at Back Surface: Steel)

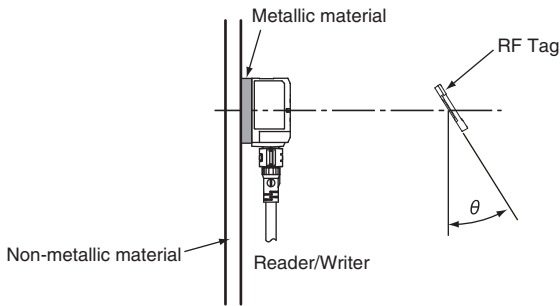

” V680S-HMD64-EIP and V680S-D8KF67M
(Metal at Back Surface: Steel)

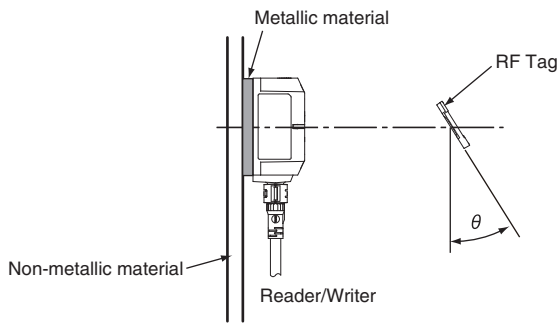

” V680S-HMD66-EIP and V680S-D8KF67M
(Metal at Back Surface: Steel)

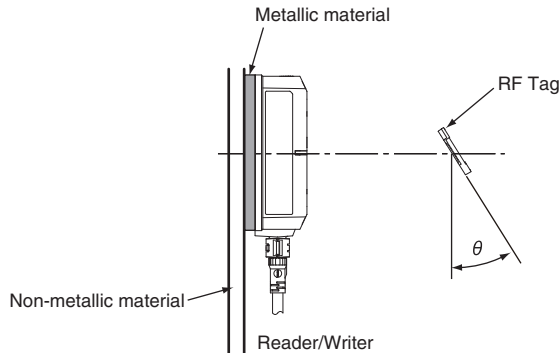

V680S-D2KF68

■ Influence of Metal at Back Surface of RF Tags

The communications range will decrease if there is metal at the back of the V680S-D2KF68 RF Tag. If the RF Tag is mounted on metallic material, use a non-metallic spacer (e.g., plastic or resin). The following graphs show the relationship between the distance from the RF Tag to the metallic surface and the communications range.

● V680S-HMD64-EIP and V680S-D2KF68

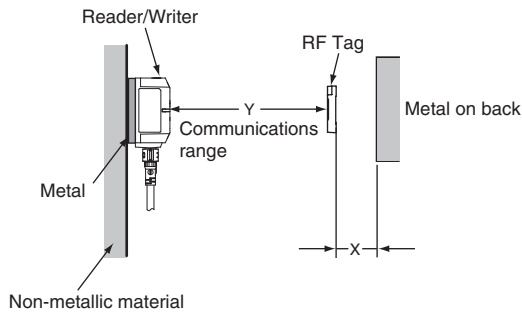
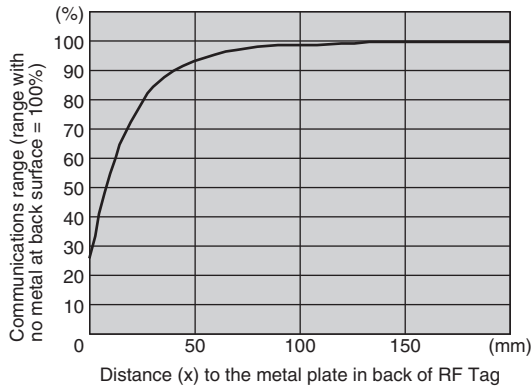

● V680S-HMD66-EIP and V680S-D2KF68

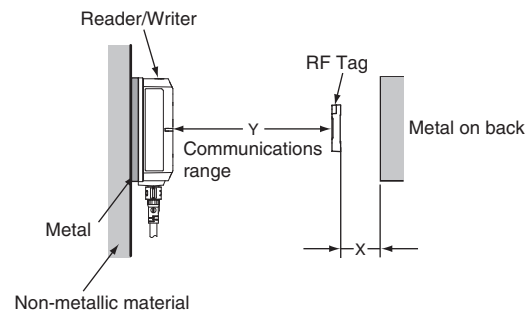
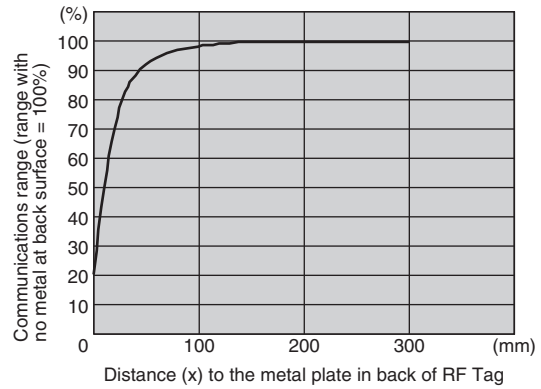

■ **Mutual Interference of RF Tags**

If you use more than one RF Tag, separate them by at least the interval shown below to prevent malfunctions due to mutual interference.

If the distance between the RF tags is too short, read / write distance will be reduced.

■ **V680S-HMD64-EIP Reader/Writer**

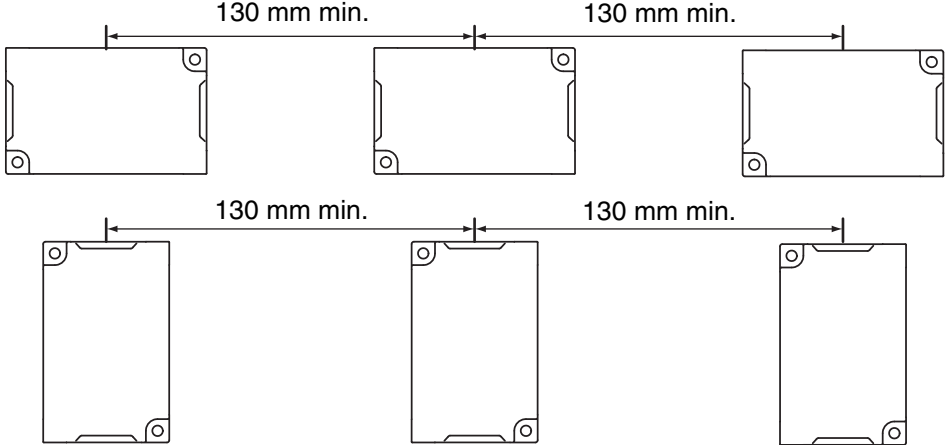

■ **V680S-HMD66-EIP Reader/Writer**

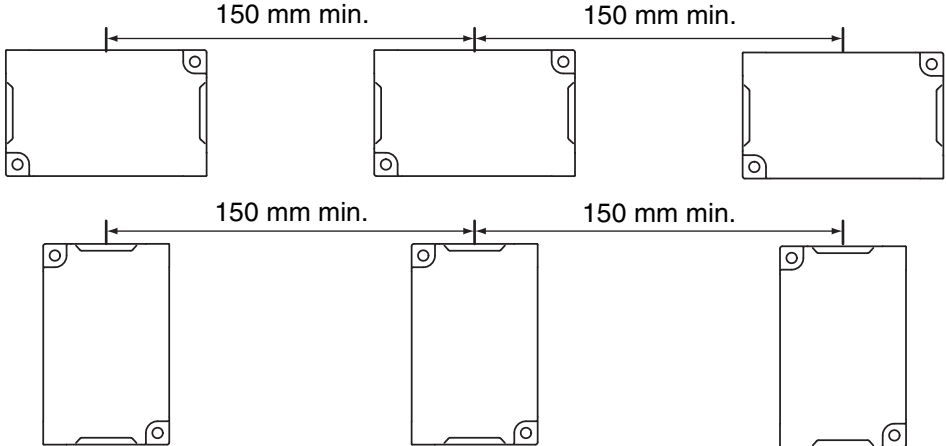

■ Influence of Inclination

Install the Reader/Writer and RF Tags so that the Reader/Writer and RF Tags are as parallel to each other as possible.

Communications will be possible even if the Reader/Writer and RF Tags are not parallel to each other; however, the communications range is affected by the inclination between them as shown in the following graphs.

■ Rates of Change in Communications Range for Inclination of V680S-D2KF68

	RF Tag inclination (θ°)									
	0	10	20	30	40	50	60	70	80	90
V680S-HMD64-EIP and V680S-D2KF68 horizontally	-0%	-1%	-2%	-3%	-6%	-9%	-14%	-21%	-33%	-59%
V680S-HMD64-EIP and V680S-D2KF68 vertically	-0%	-1%	-3%	-5%	-8%	-13%	-20%	-28%	-41%	-66%
V680S-HMD66-EIP and V680S-D2KF68 horizontally	-0%	-1%	-2%	-3%	-6%	-11%	-16%	-25%	-39%	-65%
V680S-HMD66-EIP and V680S-D2KF68 vertically	-0%	-1%	-2%	-5%	-8%	-13%	-20%	-29%	-42%	-68%

■ Measurement Conditions

” V680S-HMD64-EIP and V680S-D2KF68
Horizontally

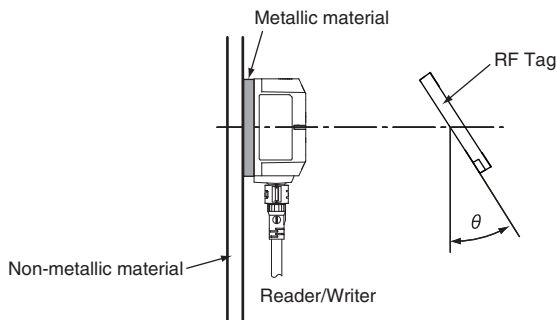

” V680S-HMD64-EIP and V680S-D2KF68
Vertically

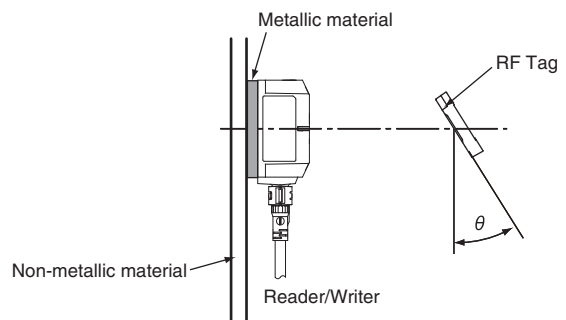

” V680S-HMD66-EIP and V680S-D2KF68
Horizontally

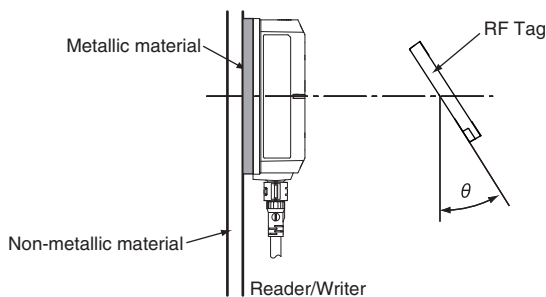

” V680S-HMD66-EIP and V680S-D2KF68
Vertically

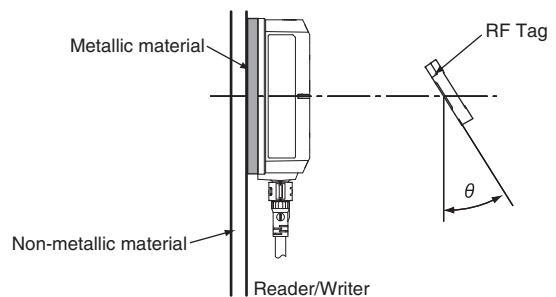

V680S-D2KF68M

■ Influence of Surrounding Metal

The V680S-D2KF68M can be surface-mounted or it can be embedded in metal. However, do not allow the height of the metal to exceed the height of the V680S-D2KF68M.

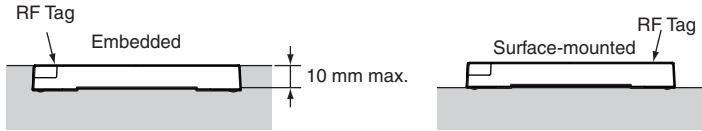

● V680S-HMD64-EIP and V680S-D2KF68M

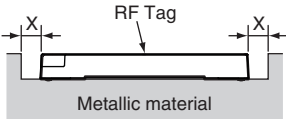
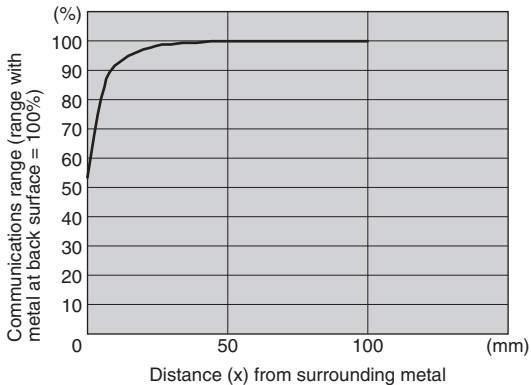

● V680S-HMD66-EIP and V680S-D2KF68M

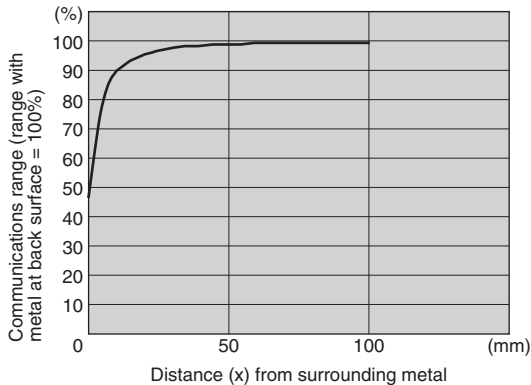

■ Mutual Interference of RF Tags

If you use more than one RF Tag, separate them by at least the interval shown below to prevent malfunctions due to mutual interference.

If the distance between the RF tags is too short, read / write distance will be reduced.

■ V680S-HMD64-EIP Reader/Writer

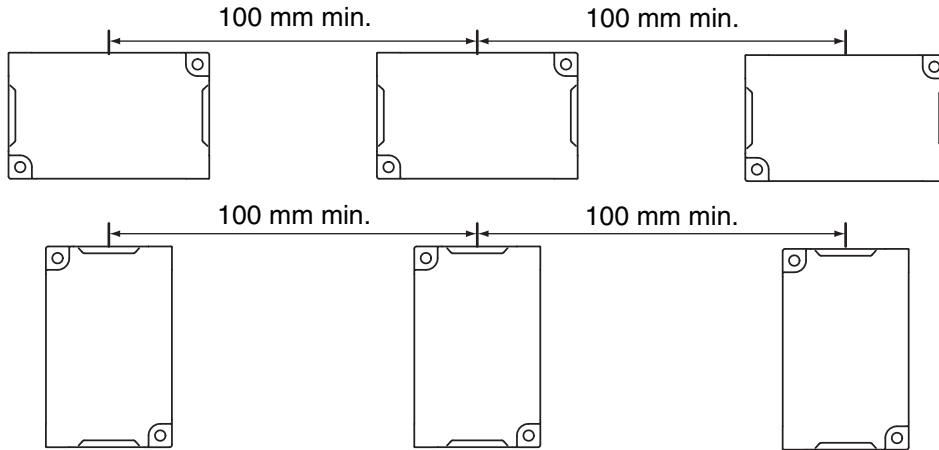

■ V680S-HMD66-EIP Reader/Writer

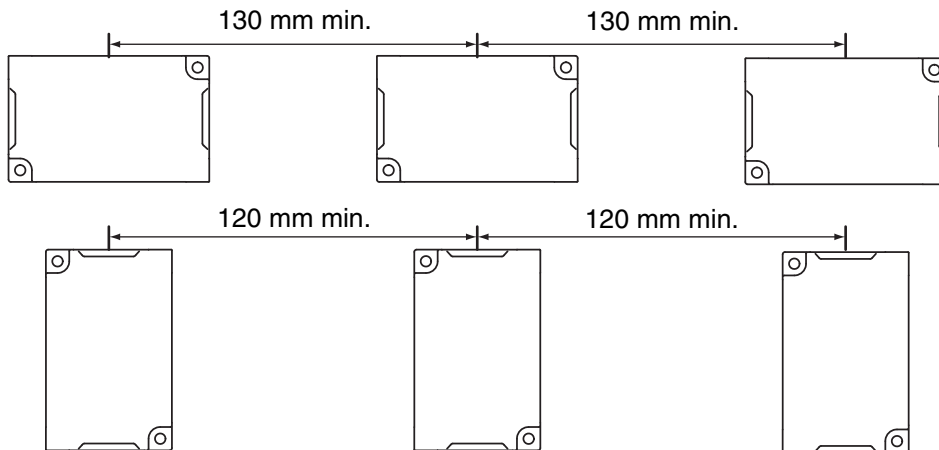

■ Influence of Inclination

Install the Reader/Writer and RF Tags so that the Reader/Writer and RF Tags are as parallel to each other as possible.

Communications will be possible even if the Reader/Writer and RF Tags are not parallel to each other; however, the communications range is affected by the inclination between them as shown in the following graphs.

■ Rates of Change in Communications Range for Inclination of V680S-D2KF68M

	RF Tag inclination (θ°)									
	0	10	20	30	40	50	60	70	80	90
V680S-HMD64-EIP and V680S-D2KF68M horizontally	0%	0%	-1%	-3%	-5%	-9%	-17%	-32%	---	---
V680S-HMD64-EIP and V680S-D2KF68M vertically	0%	-2%	-4%	-7%	-12%	-19%	-31%	-51%	---	---
V680S-HMD66-EIP and V680S-D2KF68M horizontally	0%	-1%	-2%	-4%	-8%	-13%	-23%	-43%	---	---
V680S-HMD66-EIP and V680S-D2KF68M vertically	0%	-1%	-4%	-7%	-12%	-21%	-33%	-58%	---	---

■ Measurement Conditions

" V680S-HMD64-EIP and V680S-D2KF68M
Horizontally

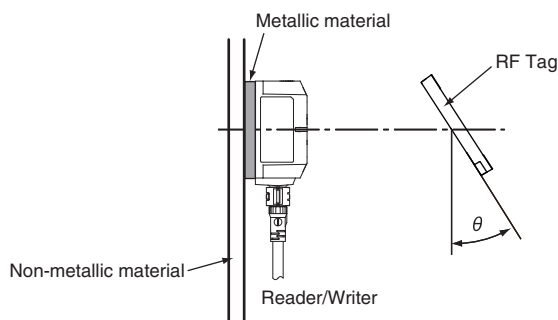

" V680S-HMD64-EIP and V680S-D2KF68M
Vertically

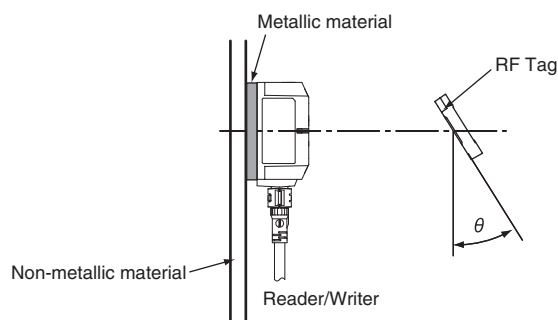

" V680S-HMD66-EIP and V680S-D2KF68M
Horizontally

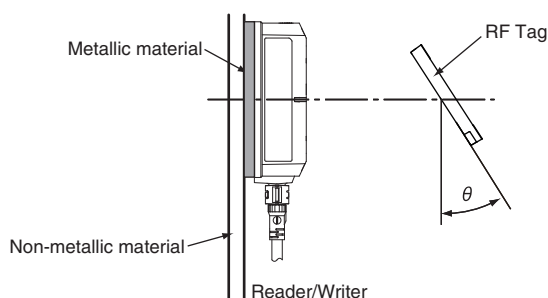

" V680S-HMD66-EIP and V680S-D2KF68M
Vertically

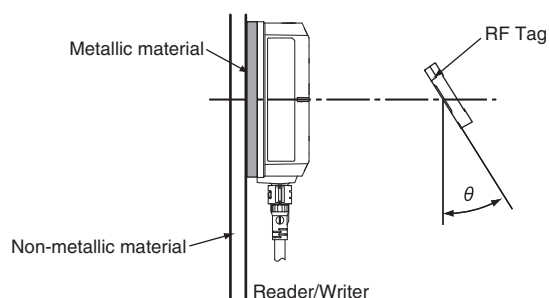

V680S-D8KF68

■ Influence of Metal at Back Surface of RF Tags

The communications range will decrease if there is metal at the back of the V680S-D8KF68 RF Tag. If the RF Tag is mounted on metallic material, use a non-metallic spacer (e.g., plastic or resin). The following graphs show the relationship between the distance from the RF Tag to the metallic surface and the communications range.

● V680S-HMD64-EIP and V680S-D8KF68

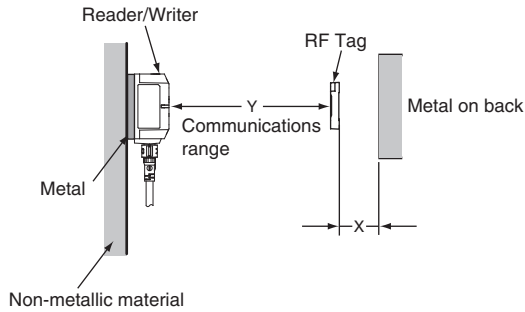
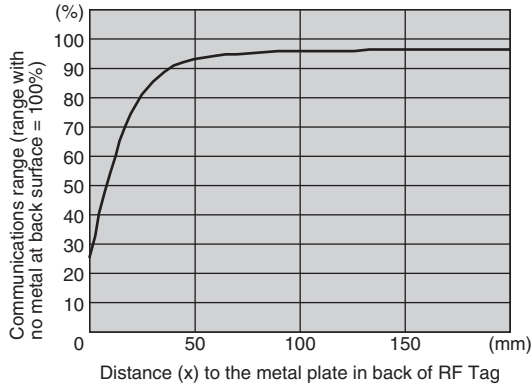

● V680S-HMD66-EIP and V680S-D8KF68

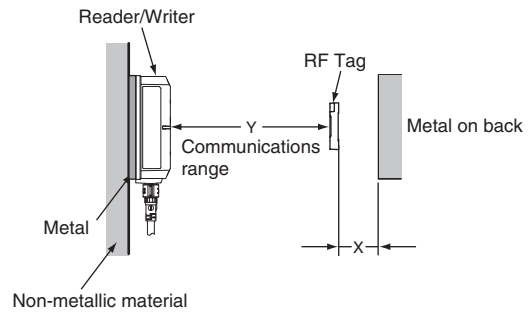
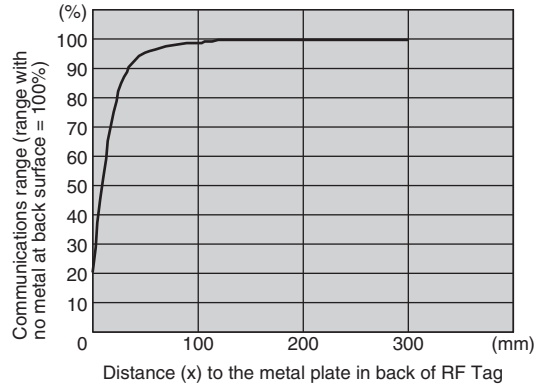

■ **Mutual Interference of RF Tags**

If you use more than one RF Tag, separate them by at least the interval shown below to prevent malfunctions due to mutual interference.

If the distance between the RF tags is too short, read / write distance will be reduced.

■ **V680S-HMD64-EIP Reader/Writer**

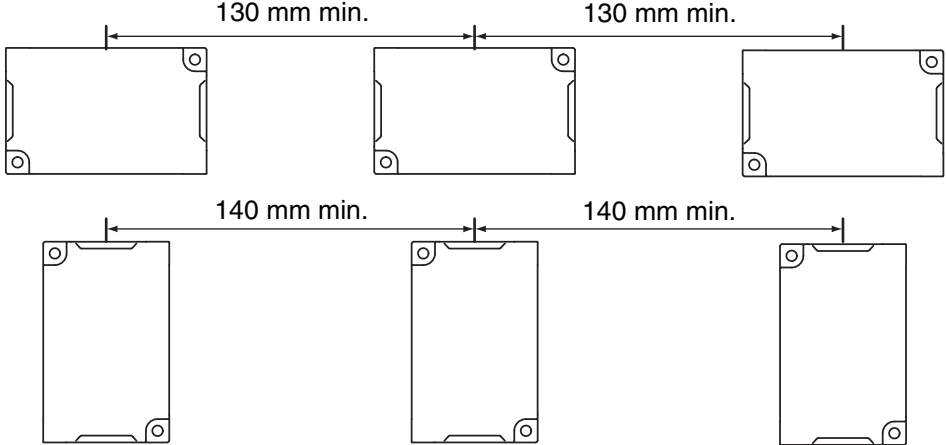

■ **V680S-HMD66-EIP Reader/Writer**

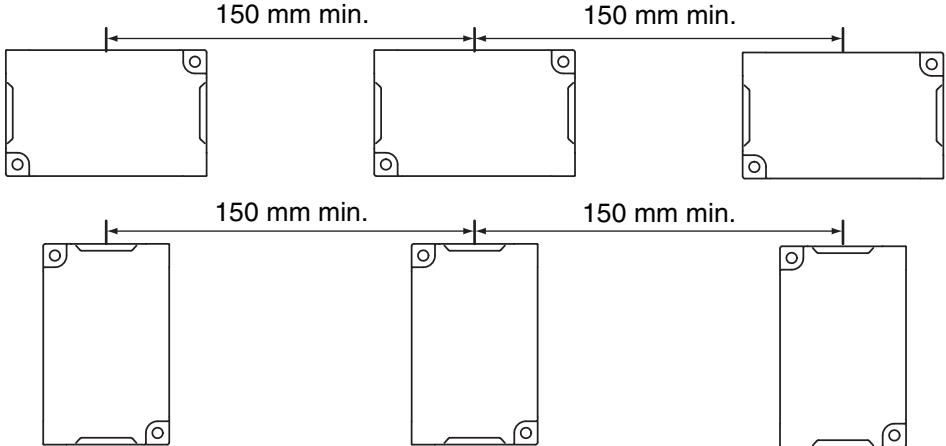

■ Influence of Inclination

Install the Reader/Writer and RF Tags so that the Reader/Writer and RF Tags are as parallel to each other as possible.

Communications will be possible even if the Reader/Writer and RF Tags are not parallel to each other; however, the communications range is affected by the inclination between them as shown in the following graphs.

■ Rates of Change in Communications Range for Inclination of V680S-D8KF68

	RF Tag inclination (θ°)									
	0	10	20	30	40	50	60	70	80	90
V680S-HMD64-EIP and V680S-D8KF68 horizontally	0%	-1%	-2%	-3%	-5%	-9%	-14%	-21%	-32%	-58%
V680S-HMD64-EIP and V680S-D8KF68 vertically	0%	-1%	-3%	-5%	-8%	-13%	-19%	-28%	-41%	-65%
V680S-HMD66-EIP and V680S-D8KF68 horizontally	0%	-1%	-2%	-3%	-6%	-11%	-16%	-25%	-39%	---
V680S-HMD66-EIP and V680S-D8KF68 vertically	0%	-1%	-2%	-5%	-8%	-14%	-20%	-29%	-43%	-69%

■ Measurement Conditions

” V680S-HMD64-EIP and V680S-D8KF68

Horizontally

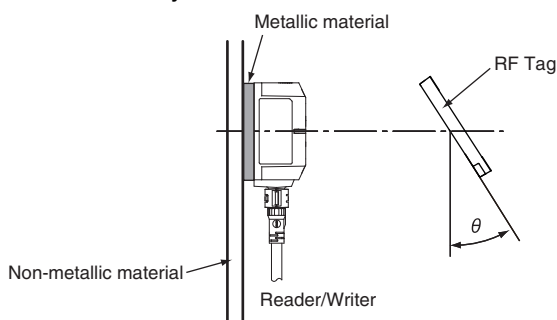

” V680S-HMD64-EIP and V680S-D8KF68

Vertically

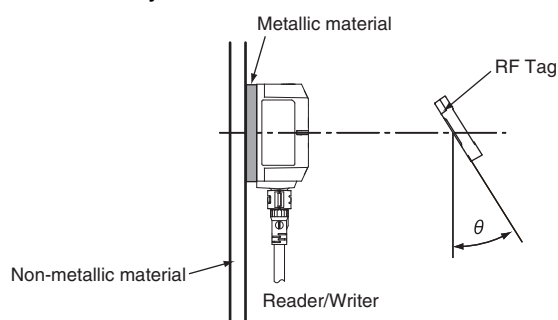

” V680S-HMD66-EIP and V680S-D8KF68

Horizontally

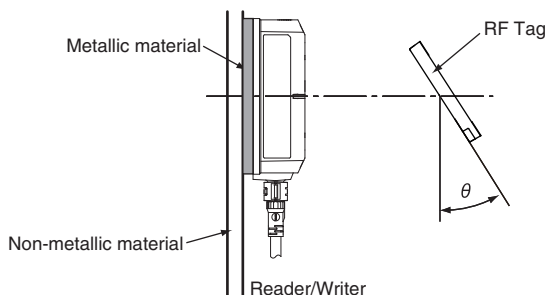

” V680S-HMD66-EIP and V680S-D8KF68

Vertically

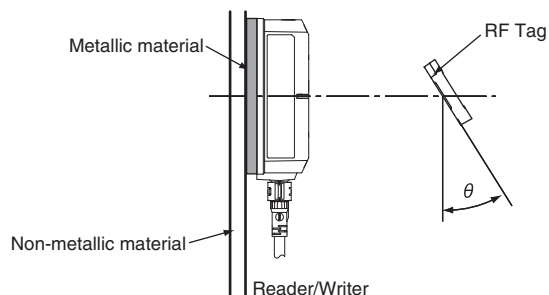

V680S-D8KF68M

■ Influence of Surrounding Metal

The V680S-D8KF68M can be surface-mounted or it can be embedded in metal. However, do not allow the height of the metal to exceed the height of the V680S-D8KF68M.

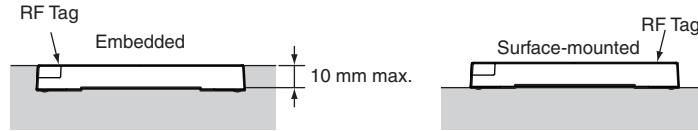

● V680S-HMD64-EIP and V680S-D8KF68M

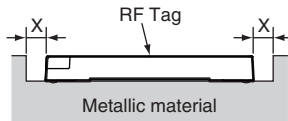
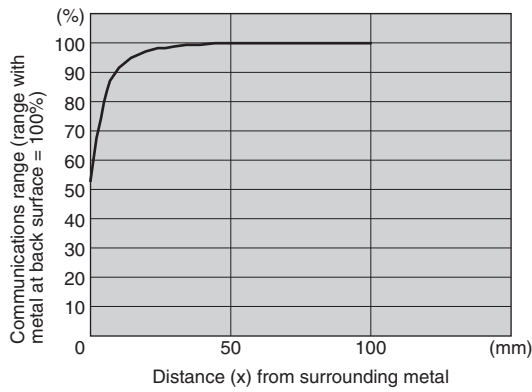

● V680S-HMD66-EIP and V680S-D8KF68M

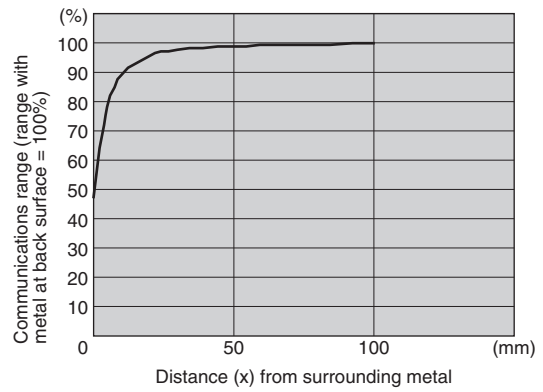

■ Mutual Interference of RF Tags

If you use more than one RF Tag, separate them by at least the interval shown below to prevent malfunctions due to mutual interference.

If the distance between the RF tags is too short, read / write distance will be reduced.

■ V680S-HMD64-EIP Reader/Writer

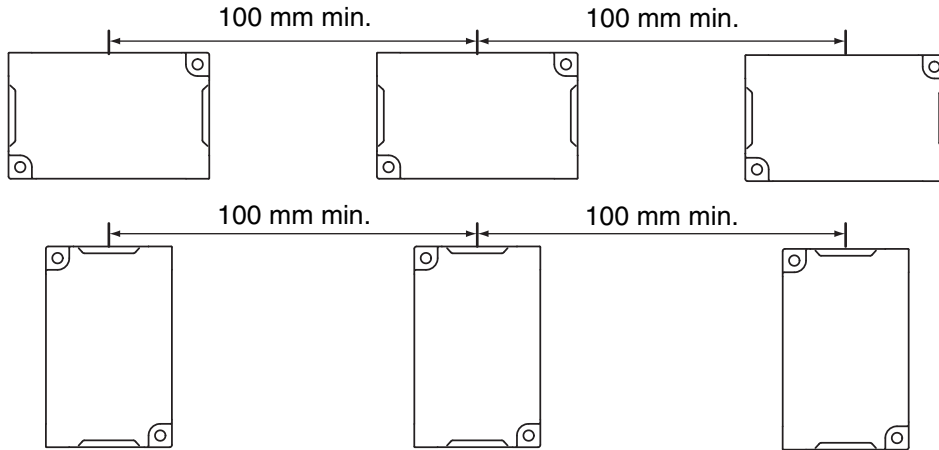

■ V680S-HMD66-EIP Reader/Writer

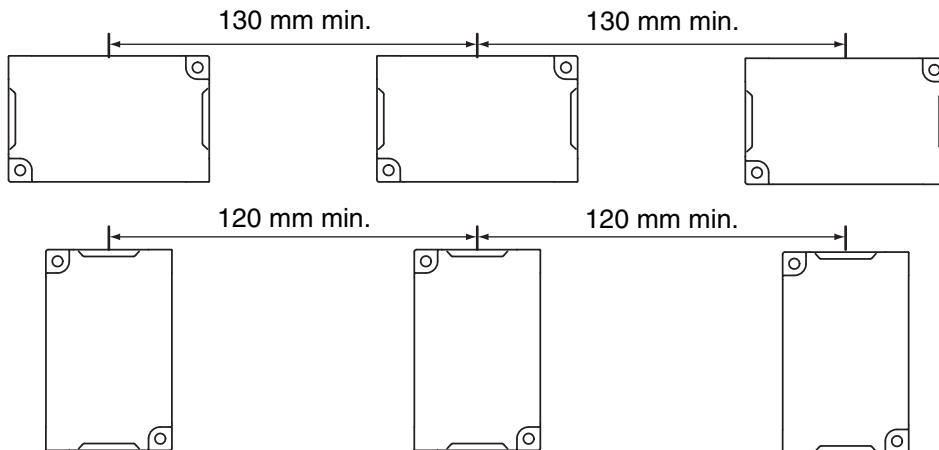

■ Influence of Inclination

Install the Reader/Writer and RF Tags so that the Reader/Writer and RF Tags are as parallel to each other as possible.

Communications will be possible even if the Reader/Writer and RF Tags are not parallel to each other; however, the communications range is affected by the inclination between them as shown in the following graphs.

■ Rates of Change in Communications Range for Inclination of V680S-D8KF68M

	RF Tag inclination (θ°)									
	0	10	20	30	40	50	60	70	80	90
V680S-HMD64-EIP and V680S-D8KF68M horizontally	0%	-1%	-1%	-3%	-5%	-9%	-16%	-29%	---	---
V680S-HMD64-EIP and V680S-D8KF68M vertically	0%	-1%	-3%	-7%	-12%	-19%	-30%	-52%	-56%	---
V680S-HMD66-EIP and V680S-D8KF68M horizontally	0%	-1%	-2%	-4%	-8%	-13%	-24%	-50%	---	---
V680S-HMD66-EIP and V680S-D8KF68M vertically	0%	-1%	-4%	-8%	-13%	-22%	-35%	-67%	---	---

Measurement Conditions

" V680S-HMD64-EIP and V680S-D8KF68M
Horizontally

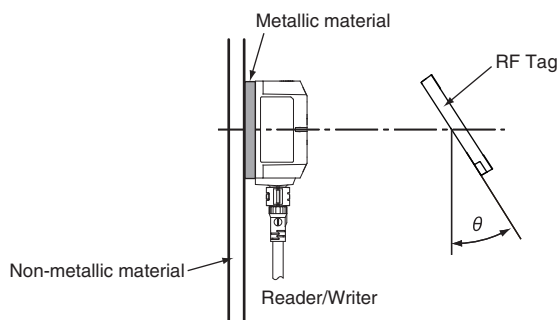

" V680S-HMD64-EIP and V680S-D8KF68M
Vertically

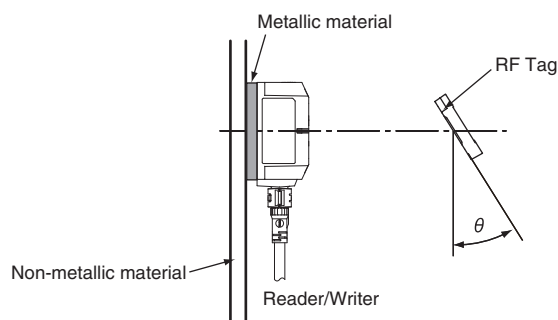

" V680S-HMD66-EIP and V680S-D8KF68M
Horizontally

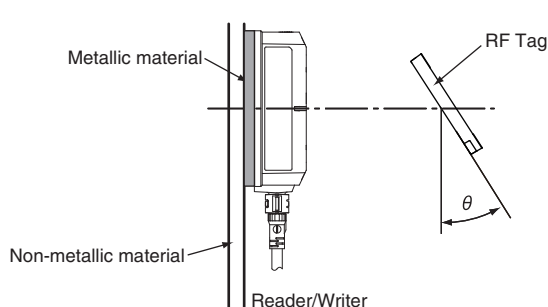

" V680S-HMD66-EIP and V680S-D8KF68M
Vertically

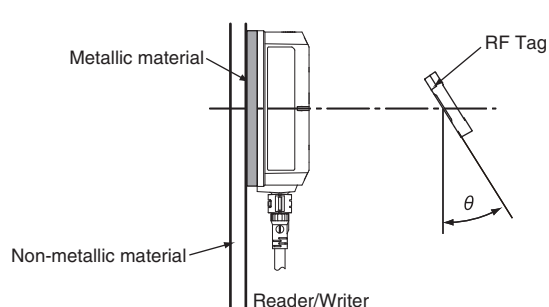

RF Tag Memory Capacities and Memory Types

(As of July 2019)

Model	Memory capacity (user memory)	Memory type	Life expectancy
V680-D1KP54T V680-D1KP66T V680-D1KP66MT V680-D1KP66T-SP	1,000 bytes	EEPROM	<ul style="list-style-type: none"> • Write endurance: 100,000 times per block (25°C) • Data retention: 10 years after writing (85°C or less)
V680-D1KP58HTN			<ul style="list-style-type: none"> • Write endurance: 100,000 times per block (25°C) • Data retention: 10 years after writing (85°C or less) * Total data retention at high temperatures exceeding 125°C is 10 hours
V680S-D2KF67 V680S-D2KF67M V680S-D2KF68 V680S-D2KF68M	2,000 bytes	FRAM	<ul style="list-style-type: none"> • Access frequency: One trillion times • Data retention: 10 years after writing (85°C or less)
V680S-D8KF67 V680S-D8KF67M V680S-D8KF68 V680S-D8KF68M	8,192 bytes		

RF Tag Memory Map

V680-D1KP□□ RF Tags

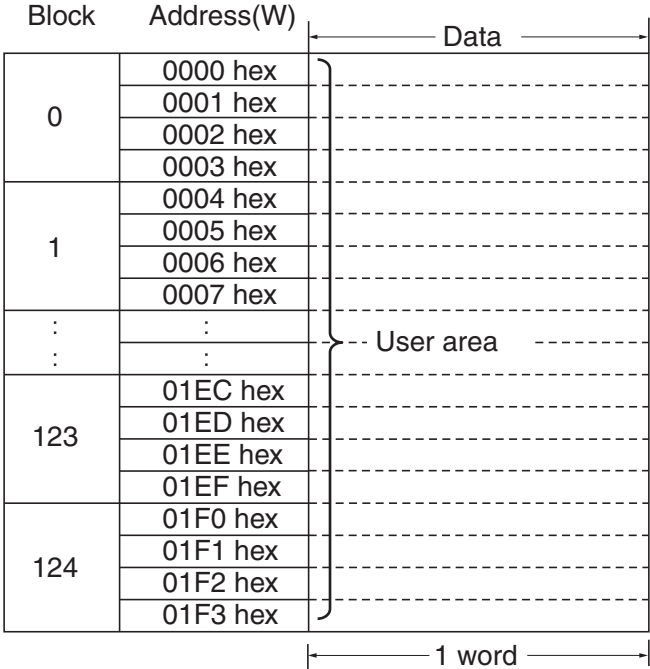

EEPROM is used as the memory in the RF Tag.
The user-accessible capacity is 1,000 bytes.

V680S-D2KF6 RF Tags

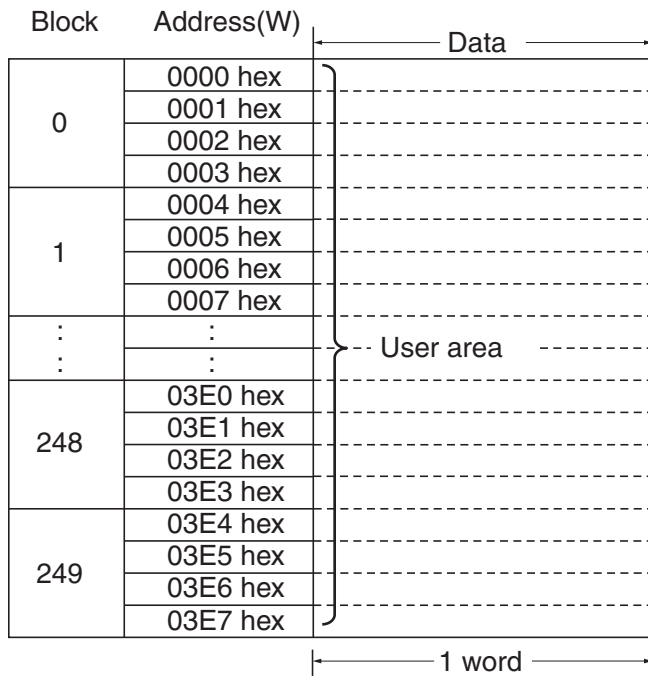

FRAM is used as the memory in the RF Tag.
 The user-accessible capacity is 2,000 bytes.

V680S-D8KF6 RF Tags

Block	Address(W)	Data
0	0000 hex	-----
	0001 hex	
	0002 hex	
	0003 hex	
	:	
	:	
	000C hex	
	000D hex	
	000E hex	
1	0010 hex	-----
	0011 hex	
	0012 hex	
	0013 hex	
	:	
	:	
	001C hex	
	001D hex	
	001E hex	
254	0FE0 hex	-----
	0FE1 hex	
	0FE2 hex	
	0FE3 hex	
	:	
	:	
	0FEC hex	
	0FED hex	
	0FEE hex	
255	0FEF hex	-----
	0FF0 hex	
	0FF1 hex	
	0FF2 hex	
	0FF3 hex	
	:	
	:	
	0FFC hex	
	0FFD hex	
0FFE hex		
0FFF hex		

User area

FRAM is used as the memory in the RF Tag.
The user-accessible capacity is 8,192 bytes.

1 word

Chemical Resistance of the Reader/Writers and RF Tags

Chemical Resistance of the Reader/Writers

■ Applicable Models

V680S-HMD63-EIP/-HMD64-EIP/-HMD66-EIP

The chemicals that affect the Reader/Writer are listed below.

PBT (polybutylene terephthalate) is used as the case material and a urethane resin is used as the filling. Refer to the following lists and do not use chemicals that affect PBT and urethane resins.

Reader/Writers cannot be used in applications with explosion-proof specifications.

■ Chemicals That Cause Deformations, Cracks, Etc.

Chemical name
Acetone, trichloroethylene, ethylene dichloride, sodium hydroxide, and other alkaline substances, hydrochloric acid (35% or more), nitric acid (70% or more)

■ Chemicals That May Cause Discoloration, Swelling, Etc.

Chemical name
Hydrochloric acid (10% RT), acetic acid (5% RT), benzene, nitric acid (20% or more)



CHECK!

The above results are from tests conducted at room temperature (23°C). Even if the chemicals do not affect the PPS or epoxy resins at room temperature, they may affect the resins at higher or lower temperatures. Check the chemicals carefully in advance.

Chemical Resistance of RF Tags

■ Applicable Models

V680-D1KP54T/-D1KP66T/-D1KP66MT/-D1KP58HTN/V680S-D□KF6□

PPS resin is used for case material. Refer to the following lists and do not use chemicals that affect PPS and epoxy resin.

RF Tags cannot be used in applications with explosion-proof specifications.

Chemical		At room temperature	At 90°C
Hydrochloric acid	37%	A	A
	10%	A	A
Sulfuric acid	98%	A	B
	50%	A	A
	30%	A	A
	3%	A	A
	60%	B	C
	40%	A	B
	10%	A	A
Hydrogen fluoride solution	40%	B	B
Chromic acid	40%	A	A
Hydrogen peroxide solution	28%	A	B
	3%	A	A
Sodium hydroxide solution	60%	A	A
	10%	A	A
	1%	A	A
Ammonia solution	28%	A	B
	10%	A	B
Sodium chloride	10%	A	A
Sodium carbonate	20%	A	A
	2%	A	A

Chemical		At room temperature	At 90°C
Sodium hypochlorite		A	A
Phenol solution	5%	A	A
Glacial acetic acid		A	A
Acetic acid		A	A
Oleic acid		A	A
Methyl alcohol	95%	A	A
Ethyl alcohol	95%	A	A
Ethyl acetate		A	A
Sebacic acid diethylhexyl		A	A
Acetone		A	A
Diethyl ether		A	A
n-heptane		A	A
2-2-4 trimethylpentane		A	A
Benzene		A	A
Toluene		A	A
Aniline		A	A
Mineral oil		A	A
Gasoline		A	A
Insulating oil		A	A
Dichloroethylene		A	A
Carbon tetrachloride		A	A

A: Has no adverse effect, B: May cause discoloration, swelling, etc., C: Causes deformation, cracks, etc.



CHECK!

The above table shows the extent of changes in PPS resin exposed to each chemical at room temperature and at 90°C. If actual chemicals, concentrations, and temperatures are different from those shown in the tables, always conduct tests under the actual conditions in which the RF Tags are to be used.

■ Applicable Models

V680-D1KP66T-SP

PFA resin is used for exterior case material. Refer to the following lists and do not use chemicals that affect PFA resin.

RF Tags cannot be used in applications with explosion-proof specifications.

■ Chemical Resistance of Fluoroplastic PFA (Reference)

PFA: Tetrafluoroethylene-Perfluoroalkylvinylether Copolymer

Fluoroplastic PFA does not react with most chemicals except molten alkali metal, hot pressurized fluorine (F₂), and some halogen derivatives. The following tables show the results of tests in which PFA was soaked in or exposed to commonly used organic and inorganic chemicals. In these tests, a compression-molded test piece (1.3 mm thick) was soaked in the chemical at a specified temperature for a week (168 hours) and taken out of the chemical, then the weight change, tensile strength, and elongation of the test piece were immediately measured. If the change in the tensile strength is 15 % or less, the range in the elongation is 10 % or less, and the increase in the weight is less than 0.5 %, the results of the test can be considered normal.

If PFA is exposed to trichloroacetic acid, tri-n-butyl phosphate, perchloroethylene, carbon tetrachloride, and other liquids (which easily make resin surfaces wet) at a high temperature, it tends to increase its weight due to absorption and reduce its tensile strength. Even when PFA absorbs chemicals and solvents, its molecular structure will not change. If, however, PFA is subject to temperature or pressure changes or mechanical damage when it has absorbed chemicals, the chemicals will repeatedly expand and contract inside pfa, causing mechanical problems such as cracks and bulging. In fact, this problem occurs with any kind of plastic.

■ Inorganic Chemicals

Chemical name	Test temperature (°C)	Resulting characteristics (%)		Weight increase rate (%)
		Tensile strength	Elongation	
Concentrated hydrochloric acid	120	98	100	0.0
Concentrated sulfuric acid	120	95	98	0.0
Hydrofluoric acid (60%)	23	99	99	0.0
Fuming sulfuric acid	23	95	96	0.0
Aqua regia	120	99	100	0.0
Chromic acid (50%)	120	93	97	0.0
Concentrated nitric acid	120	95	98	0.0
Fuming nitric acid	23	99	99	0.0
Concentrated ammonia solution	66	98	100	0.0
Caustic soda (50%)	120	93	99	0.4
Hydrogen peroxide solution (30%)	23	93	95	0.0
Bromine	23	99	100	0.5
Chlorine	120	92	100	0.5
Ferrous chloride (25%)	100	93	98	0.0
Zinc chloride (25%)	100	96	100	2.7
Chlorosulfonic acid	151	91	100	2.7
Concentrated phosphoric acid	100	93	100	0.0

▪ Organic Chemicals

Chemical name	Test temperature (°C)	Resulting characteristics (%)		Weight increase rate (%)
		Tensile strength	Elongation	
Glacial acetic acid	118	95	100	0.4
Acetic anhydride	139	91	99	0.3
Trichloroacetic acid	196	90	100	2.2
Isooctane	99	94	100	0.7
Naphtha	100	91	100	0.5
Mineral oil	180	87	95	0.0
Toluene	110	88	100	0.7
o-creosol	191	92	96	0.2
Nitrobenzene	210	90	100	0.3
Benzyl alcohol	205	93	99	0.3
Aniline	185	94	100	0.3
n-butylamine	78	86	97	0.4
Ethylenediamine	117	96	100	0.1
Tetrahydrofuran	66	88	100	0.1
Benzaldehyde	179	90	99	0.5
Cyclohexane	156	92	100	0.4
Methyl ethyl ketone	80	90	100	0.4
Acetophenone	202	90	100	0.6
Dimethylphtalate	200	98	100	0.3
n-butyl acetate	125	93	100	0.5
Tri-n-butyl phosphate	200	91	100	2.0
Methylene chloride	40	94	100	0.8
Perchloroethylene	121	86	100	2.0
Carbon tetrachloride	77	87	100	2.3
Dimethyl formamide	154	96	100	0.2
Dimethyl sulfoxide	189	95	100	0.1
Dioxane	101	92	100	0.6

Reference: *Fluoroplastics Handbook*, The Nikkan Kogyo Shimbun Ltd. (Takaomi Satogawa)

Degree of Protection

Ingress protection degrees (IP-□□) are determined by the following tests. Be sure to check the sealing capability under the actual operating environment and conditions before actual use.

■ IEC (International Electrotechnical Commission) IEC 60529:2001

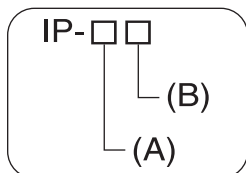







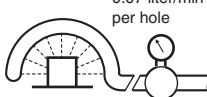

(A) First Digit: Degree of Protection from Solid Materials

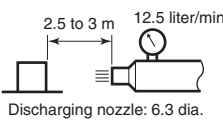
Degree	Protection	
0		No protection
1		Protects against penetration of any solid object such as a hand that is 50 mm or more in diameter.
2		Protects against penetration of any solid object, that is 12.5 mm or more in diameter. Even if finger or other object 12 mm in diameter penetrates, it will not reach a hazardous part.
3		Protects against penetration of any solid object, such as a wire, that is 2.5 mm or more in diameter.
4		Protects against penetration of any solid object, such as a wire, that is 1 mm or more in diameter.
5		Protects against penetration of dust of a quantity that may cause malfunction or obstruct the safe operation of the product.
6		Protects against penetration of all dust.

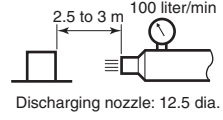
(B) Second Digit: Degree of Protection Against Water

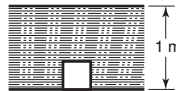
Degree	Protection		Test method (with pure water)
0	No protection	Not protected against water.	No test
1	Protection against water drops 	Protects against vertical drops of water towards the product.	Water is dropped vertically towards the product from the test machine for 10 min.
2	Protection against water drop 	Protects against drops of water approaching at a maximum angle of 15° to the left, right, back, and front from vertical towards the product.	Water is dropped for 25 min each (i.e., 10 min in total) towards the product inclined 15° to the left, right, back, and front from the test machine.
3	Protection against sprinkled water 	Protects against sprinkled water approaching at a maximum angle of 60° from vertical towards the product.	Water is sprinkled for 10 min at a maximum angle of 60° to the left and right from vertical from the test machine.

Degree	Protection		Test method (with pure water)
4	Protection against water spray 	Protects against water spray approaching at any angle towards the product.	Water is sprayed at any angle towards the product for 10 min from the test machine. 
5	Protection against water jet spray 	Protects against water jet spray approaching at any angle towards the product.	Water is jet sprayed at any angle towards the product for 1 min per square meter for at least 3 min in total from the test machine. 
6	Protection against high pressure water jet spray 	Protects against high-pressure water jet spray approaching at any angle towards the product.	Water is jet sprayed at any angle towards the product for 1 min per square meter for at least 3 min in total from the test machine. 
7	Protection against limited immersion in water 	Resists the penetration of water when the product is placed underwater at specified pressure for a specified time.	The product is placed 1 m deep in water (if the product is 850 mm max. in height) for 30 min. 
8 (See note.)	Protection against long-term immersion in water 	Can be used continuously underwater.	The test method is determined by the manufacturer and user.

Note: OMRON Test Method

Usage condition: 10 m or less under water in natural conditions

1. No water ingress after 1 hour under water at 2 atmospheres of pressure.
2. Sensing distance and insulation resistance specifications must be met after 100 repetitions of half hour in 5°C water and half hour in 85°C water.

About IPX9K

IPX9K is a protection standard regarding high temperature and high-pressure water which is defined by the German standard (DIN 40050 PART9).

Water is sprayed on 80 °C hot water with the water pressure of 80 to 100BAR from a nozzle to the test piece.

Amount of water is 14 to 16 liters/minute.

The distance between the test piece and a nozzle is 10 to 15 cm, and the directions of water-drainage are 0 degrees, 30 degrees, 60 degrees, and 90 degrees horizontally.

They are evaluated with the test piece is rotating on a horizontal plane by 30 seconds in each direction.

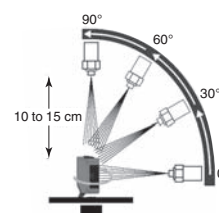

Oil Resistance (OMRON in-house standard)

Protection	
Oil-resistant	No adverse affect from oil drops or oil spray approaching from any direction.
Oil-proof	Protects against penetration of oil drops or oil spray approaching from any direction.

Note. Oil resistance has been tested using a specific oil as defined in the OMRON test method. (JIS C 0920:2003, Appendix 1)

Differences in Address and Size Specifications between V680 and V680S Reader/Writers

RF Tag access for V680S-series Reader/Writers is performed in words (1 word = 2 bytes). RF Tag access for V680-series Controllers is performed in bytes. Be sure to access data in the correct units.

The word and byte addresses for the memory map of a V680-D1KP□□ RF Tag are given below as a concrete example.

Word address	Byte address	Data
0000 hex	0000 hex	-----
	0001 hex	
0001 hex	0002 hex	-----
	0003 hex	
0002 hex	0004 hex	-----
	0005 hex	
0003 hex	0006 hex	-----
	0007 hex	
⋮	⋮	-----
	⋮	
01F2 hex	03E4 hex	-----
	03E5 hex	
01F3 hex	03E6 hex	-----
	03E7 hex	
		← 1 byte →

Because you cannot access data in bytes for a V680S-series Reader/Writer, you cannot, for example, read six bytes of data starting from address (byte address) 0001 hex. In this case, you would have to read four words from address (word address) 0000 hex and discard the first and last bytes at the host device.



Data is accessed in words for a V680S-series Reader/Writer. The smallest accessible unit is therefore one word (two bytes).

CHECK!

Index

Index

A

Auto 94

B

Browser Operation Window 188

C

Command Error Log 106
 Communication Diagnostic 108
 Communications Diagnostic 104
 Communications Option Setting 103
 Communications Options 93
 Communications Range Specifications 42
 Communications Settings View 193
 Component Names 58
 Configuration 203
 Configuration File 208
 Connections and Wiring 78
 Connector Cover (Slim Type) 29
 Convenient Functions 107
 COPY DATA 163

D

Data Characteristics 42, 242
 DATA FILL 160

E

Error Descriptions 212
 Error Logs 106
 EtherNet/IP Communications Protocol 146

F

Fatal Errors 212, 214
 Field Extension Mode 115
 FIFO Repeat 96

G

GET COMMAND ERROR LOG 176
 GET FIRMWARE VERSION 173
 GET MODEL INFORMATION 172
 GET MULTI-READER/WRITER
 SETTINGS 170
 GET MULTI-READER/WRITER
 STATUS 180
 GET OPERATING TIME 174
 GET RESTORE INFORMATION 178
 GET RF TAG COMMUNICATIONS
 SETTINGS 167

H

High-speed Traveling Mode 116

I

Initialization 102
 INITIALIZE 165
 Installation 66
 IP Address Duplication Error 218
 IP Address, Subnet Mask, and Default
 Gateway 105

L

LOCK 159
 Log View 196

M

Maintenance 101
 Maintenance and Inspection 240
 MEASURE NOISE 175
 Multi-Reader/Writer Operation 113

N

Network Settings 105
 Network Settings View 192
 Noise Measurement 101
 Noise Monitor View 197
 Nonfatal Errors 213, 216
 Normal RF Tag Communications 98

O

Once 94
 Operation Mode 92

P

Password Entry View 190
 Product Specifications 25

R

READ DATA 157
 READ ID 156
 Reader/Writer 25, 58
 Reader/Writer Controls 100
 Reader/Writer Installation Precautions 254
 Reader/Writer Operation Errors 217
 Reading Device Information 101
 Reboot 202
 Repeat 95
 RESET 100, 181
 RESTORE DATA 162
 RF Analyzer 111, 198
 RF Tag 30, 62
 RF Tag Communications 93
 RF Tag Communications Errors 221
 RF Tag Communications Range
 (for Reference Only) 242
 RF Tag Communications Speed
 Setting 104
 RF Tag Communications Time
 (for Reference Only) 250

RF Tag Communications View	195
RF Tag Installation Precautions	259
RF TAG OVERWRITE COUNT CONTROL	161
RFID System Maintenance	108
Run Mode	92

S

Safe Mode	92, 237
SET MULTI-READER/WRITER OPERATION	168, 194
SET RF TAG COMMUNICATIONS	166
Setting Communications Conditions	103
Setting Functions	102
Setting the Web Password	105
Status View	191
System Configuration	52
System Error Log	106
System Errors	218

T

Tag Data Link Error	216
Tag Memory Management	98
Time Charts	182
Troubleshooting Flowcharts	222

V

V680S Command Details	156
V680S Command Errors	220

W

Web Server	107
WRITE DATA	158
Write Verification	104

Revision History

A manual revision code appears as a suffix to the catalog number at the bottom of the front and rear pages.

Man. No.: Z353-E1-11

↑
Revision code

Revision code	Date	Revised contents
01	January 2015	Original production
02	March 2015	Changed the timing chart for <i>Using the Repeat or FIFO Repeat Communications Option</i> and made other minor changes.
03	August 2015	Changed model numbers of the recommended cable for Ethernet cable and Power cable, and changed the information for RF Tag Communications Time.
04	September 2015	Added information on RF Tag Communications Time. Made other minor changes.
05	April 2016	Added information on Compliance standards and Frequency to the General Specifications of the Reader/Writer's. Added information on Compliance standards, Ambient operating temperature, Ambient storage humidity, and Dimensions to the General Specifications of the RF Tags. Added the information to the system configuration Changed the information on the mounting bracket of Reader/Writer, V680-D1KP66MT, and V680-D8KF67M. Added information on the delaying and the stopping of the Ethernet packet. Made other minor changes.
06	July 2016	Changed the configuration of the section.
07	October 2016	Change the description of the operating environment of the WEB browser. Added the information for "Firmware Version Update History". Changed the information for "Mutual Interference of Reader/Writers (for Reference Only)" of the V680S-HMD63-EIP and V680S-HMD64-EIP.
08	February 2017	Changed the information for "FIFO Repeat".
09	April 2017	Addition of description of communication function "Auto", "FIFO Repeat (Without ID code check)" and "FIFO Repeat (With ID code check)" The layout change of WEB browser.
10	July 2019	Changed the description of Java version. Added items for the V680S-A63-S, and V680-A64-S. Deleted items for V680-D8KF67, V680-D8KF67M, and V680-D8KF68A RF Tags,
11	December 2019	Changed the configuration for setting communication conditions (Addition of setting procedure for IP address of the personal computer) Made other minor changes.

Firmware Version Update History

V680S Reader/Writers: The following table gives an update history of the firmware version of the V680S-HMD6□-EIP Series.

Firmware version	Revised contents
3.00	Original production
3.01	WEB browser interface can be used in the Java8 update74 or later.
3.02	Addition of communication option "Auto" and "FIFO Repeat (With ID code check)" The layout change of WEB browser.

MEMO

OMRON Corporation Industrial Automation Company
Tokyo, JAPAN

Contact: www.ia.omron.com

Regional Headquarters

OMRON EUROPE B.V.

Wegalaan 67-69, 2132 JD Hoofddorp
The Netherlands

Tel: (31)2356-81-300/Fax: (31)2356-81-388

OMRON ELECTRONICS LLC

2895 Greenspoint Parkway, Suite 200
Hoffman Estates, IL 60169 U.S.A

Tel: (1) 847-843-7900/Fax: (1) 847-843-7787

OMRON ASIA PACIFIC PTE. LTD.

No. 438A Alexandra Road # 05-05/08 (Lobby 2),
Alexandra Technopark,
Singapore 119967

Tel: (65) 6835-3011/Fax: (65) 6835-2711

OMRON (CHINA) CO., LTD.

Room 2211, Bank of China Tower,
200 Yin Cheng Zhong Road,
PuDong New Area, Shanghai, 200120, China

Tel: (86) 21-5037-2222/Fax: (86) 21-5037-2200

Authorized Distributor:

© OMRON Corporation 2015-2017 All Rights Reserved.
In the interest of product improvement,
specifications are subject to change without notice.

Man. No. Z353-E1-11

1219(0115)