

Cat. No. Z116-E1-03

V600-series ID System

Intelligent Flag and Intelligent Flag II

OPERATION MANUAL

OMRON

V600-series ID System

Intelligent Flag and Intelligent Flag II

Revised April 2004

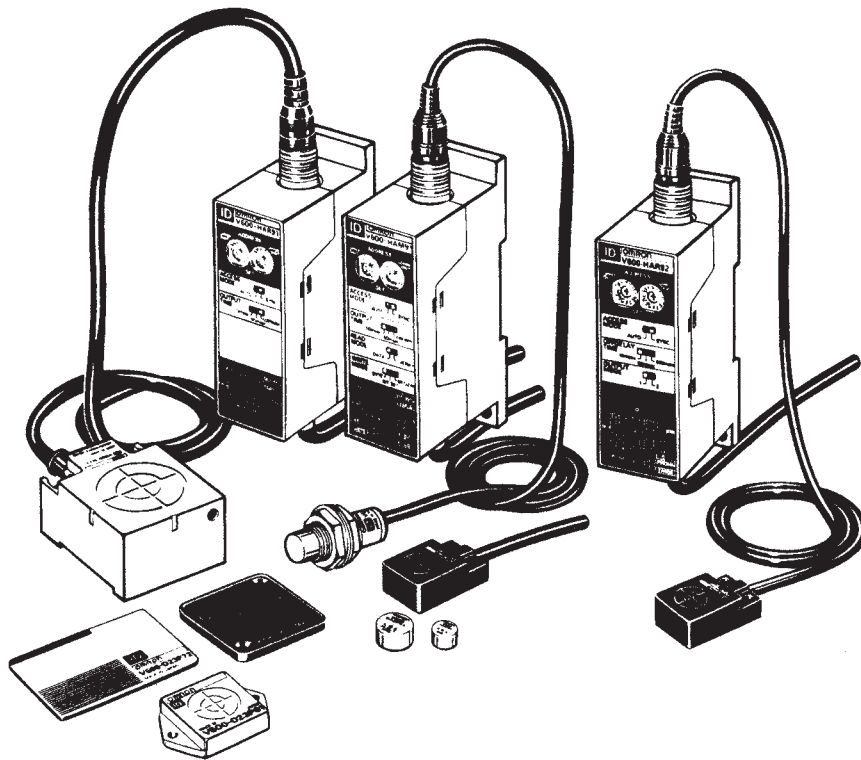

Read and Understand this Manual

Please read and understand this manual before using the products. Please consult your OMRON representative if you have any questions or comments.

Warranty, Limitations of Liability

WARRANTY

OMRON's exclusive warranty is that the products are free from defects in materials and workmanship for a period of one year (or other period if specified) from date of sale by OMRON.

OMRON MAKES NO WARRANTY OR REPRESENTATION, EXPRESS OR IMPLIED, REGARDING NON-INFRINGEMENT, MERCHANTABILITY, OR FITNESS FOR PARTICULAR PURPOSE OF THE PRODUCTS. ANY BUYER OR USER ACKNOWLEDGES THAT THE BUYER OR USER ALONE HAS DETERMINED THAT THE PRODUCTS WILL SUITABLY MEET THE REQUIREMENTS OF THEIR INTENDED USE. OMRON DISCLAIMS ALL OTHER WARRANTIES, EXPRESS OR IMPLIED.

LIMITATIONS OF LIABILITY

OMRON SHALL NOT BE RESPONSIBLE FOR SPECIAL, INDIRECT, OR CONSEQUENTIAL DAMAGES, LOSS OF PROFITS OR COMMERCIAL LOSS IN ANY WAY CONNECTED WITH THE PRODUCTS, WHETHER SUCH CLAIM IS BASED ON CONTRACT, WARRANTY, NEGLIGENCE, OR STRICT LIABILITY.

In no event shall the responsibility of OMRON for any act exceed the individual price of the product on which liability is asserted.

IN NO EVENT SHALL OMRON BE RESPONSIBLE FOR WARRANTY, REPAIR, OR OTHER CLAIMS REGARDING THE PRODUCTS UNLESS OMRON'S ANALYSIS CONFIRMS THAT THE PRODUCTS WERE PROPERLY HANDLED, STORED, INSTALLED, AND MAINTAINED AND NOT SUBJECT TO CONTAMINATION, ABUSE, MISUSE, OR INAPPROPRIATE MODIFICATION OR REPAIR.

Application Considerations

SUITABILITY FOR USE

OMRON shall not be responsible for conformity with any standards, codes, or regulations that apply to the combination of products in the customer's application or use of the products.

At the customer's request, OMRON will provide applicable third party certification documents identifying ratings and limitations of use that apply to the products. This information by itself is not sufficient for a complete determination of the suitability of the products in combination with the end product, machine, system, or other application or use.

The following are some examples of applications for which particular attention must be given. This is not intended to be an exhaustive list of all possible uses of the products, nor is it intended to imply that the uses listed may be suitable for the products:

- Outdoor use, uses involving potential chemical contamination or electrical interference, or conditions or uses not described in this manual.
- Nuclear energy control systems, combustion systems, railroad systems, aviation systems, medical equipment, amusement machines, vehicles, safety equipment, and installations subject to separate industry or government regulations.
- Systems, machines, and equipment that could present a risk to life or property.

Please know and observe all prohibitions of use applicable to the products.

NEVER USE THE PRODUCTS FOR AN APPLICATION INVOLVING SERIOUS RISK TO LIFE OR PROPERTY WITHOUT ENSURING THAT THE SYSTEM AS A WHOLE HAS BEEN DESIGNED TO ADDRESS THE RISKS, AND THAT THE OMRON PRODUCTS ARE PROPERLY RATED AND INSTALLED FOR THE INTENDED USE WITHIN THE OVERALL EQUIPMENT OR SYSTEM.

Disclaimers

PERFORMANCE DATA

Performance data given in this manual is provided as a guide for the user in determining suitability and does not constitute a warranty. It may represent the result of OMRON's test conditions, and the users must correlate it to actual application requirements. Actual performance is subject to the OMRON Warranty and Limitations of Liability.

CHANGE IN SPECIFICATIONS

Product specifications and accessories may be changed at any time based on improvements and other reasons.

It is our practice to change model numbers when published ratings or features are changed, or when significant construction changes are made. However, some specifications of the products may be changed without any notice. When in doubt, special model numbers may be assigned to fix or establish key specifications for your application on your request. Please consult with your OMRON representative at any time to confirm actual specifications of purchased products.

DIMENSIONS AND WEIGHTS

Dimensions and weights are nominal and are not to be used for manufacturing purposes, even when tolerances are shown.

ERRORS AND OMISSIONS

The information in this manual has been carefully checked and is believed to be accurate; however, no responsibility is assumed for clerical, typographical, or proofreading errors, or omissions.

Meanings of Signal Words

The following signal words are used in this manual.



Indicates a potentially hazardous situation which, if not avoided, will result in minor or moderate injury, or may result in serious injury or death. Additionally there may be significant property damage.

Meanings of Alert Symbols

The following alert symbols are used in this manual.



Indicates the possibility of explosion under specific conditions.

Alert Statements in this Manual

The following alert statements apply to the products in this manual. Each alert statement also appears at the locations needed in this manual to attract your attention.



Do not attempt to take a SRAM Data Carrier apart or expose the SRAM Data Carrier to pressures that would distort it, temperatures above 100°C, or fire. The Data Carrier has a built-in lithium battery which may catch fire or explode if not handled properly.



Precautions for Safe Use

To ensure safety, be sure to follow the following precautions:

1. Do not operate this device in any flammable, explosive, or corrosive gas environment.
2. Do not disassemble, repair, or remodel this device.
3. Tighten the base lock screws and terminal block screws completely.
4. Be sure to use wiring crimp terminals of the specified size.
5. If any cable has a locking mechanism, be sure to check that it has been locked before using it.
6. The power supply must be within the specified rating.
7. Be sure to follow any other warnings, cautions, and notices given in this manual.
8. In the event that the system gives out a foul smell, is heated abnormally in the main body portion, emits smoke, or exhibits any other abnormal condition, immediately stop using the system and turn off the power.
9. Dispose of this product as industrial waste.

Precautions for Correct Use

Please observe the following precautions to prevent failure to operate, malfunctions, or undesirable effects on product performance.

Installation Site

Install the product at a location where:

- It is not exposed to corrosive gases, dust, metal chips, or salt.
- The working temperature is within the range stipulated in the specifications.
- There are no sudden variations in temperature (no condensation).
- The relative humidity is within the range stipulated in the specifications.
- No vibration or shock exceeding the values stipulated in the specifications is transmitted directly to the body of the product.
- It is not subject to splashing water, oil, or chemical substances.

Installation

- 530 kHz frequency band to communicate with ID Tags. Some devices, such as some transceivers, motors, inverters, switching power supplies, and monitoring devices, generate electromagnetic waves (i.e., noise) that can affect communications with ID Tags. If any of these devices are nearby, communications with Data Carriers may be affected or Data Carriers may be destroyed. If the product is to be used near such devices, check the effects on communications before using the product.
- To minimize the general influence of noise, follow the following precautions:
 - (1) Ground any metallic material located around this device to 100 Ω or less.
 - (2) Wire this device keeping the wiring away from high voltage and heavy current.
- Connectors are not waterproof. Do not use the product in a humid environment.
- Do not use any chemical that may affect the materials of the product.

Cleaning

- Do not use any thinner. Resin material and case paint are dissolved by thinner.

Standard Conformity

1. FCC Rules (Federal Communications Commission)

This product complies with Part 15 Subpart C of the FCC rules.

FCC ID: E4E6CYSIDV6000190

FCC NOTICE

This device complies with part 15 of the FCC Rules. Operation is subject to the following conditions.

(1) This device may not cause harmful interference.

(2) This device must accept any interference received, including interference that may cause undesired operation.

FCC WARNING

Changes or modifications not expressly approved by the party responsible for compliance could void the user's authority to operate the equipment.

2. EC Declaration of Conformity

Hereby, OMRON Corporation declares that this RFID System, Intelligent Flag amplifier V600-HAM9 series, V600-HAM8 series and Intelligent Flag sensors V600-HS are in compliance with essential requirements and other relevant provisions of Directive 1995/5/EC, and satisfy tests for the appropriate requirements of the following relevant standards,

Radio: EN 300 330-1 V1.3.2(12-2002)

EMC: EN 301 489-3 V1.3.1(11-2001) EN 301 489-1 V1.4.1(08-2002)

Safety: EN 60950(12-2001)

Countries of intended use:

Finland, Germany (Except V600-HS67), Iceland (Except V600-HS67), Sweden

CE₀₆₇₈ 

Changes or modifications not expressly approved by the party responsible for compliance could void the user's authority to operate the equipment.

© OMRON, 1997

All rights reserved. No part of this publication may be reproduced, stored in a retrieval system, or transmitted, in any form, or by any means, mechanical, electronic, photocopying, recording, or otherwise, without the prior written permission of OMRON.

No patent liability is assumed with respect to the use of the information contained herein. Moreover, because OMRON is constantly striving to improve its high-quality products, the information contained in this manual is subject to change without notice. Every precaution has been taken in the preparation of this manual. Nevertheless, OMRON assumes no responsibility for errors or omissions. Neither is any liability assumed for damages resulting from the use of the information contained in this publication.

TABLE OF CONTENTS

| | |
|---|------------|
| SECTION 1 | |
| Features and System Configuration | 1 |
| 1-1 Features | 2 |
| 1-2 Models | 3 |
| 1-3 System Configuration | 4 |
| 1-4 Overview of System Operation | 6 |
| SECTION 2 | |
| Specifications and Performance | 7 |
| 2-1 Amplifier | 8 |
| 2-2 Sensors | 37 |
| 2-3 EEPROM Data Carriers | 39 |
| 2-4 SRAM Data Carriers | 45 |
| SECTION 3 | |
| Wireless Transmission Specifications | 53 |
| 3-1 Transmission Distance | 54 |
| 3-2 Transmission Time | 56 |
| SECTION 4 | |
| Installation | 59 |
| 4-1 Installing Amplifiers | 60 |
| 4-2 Installing Sensors | 64 |
| 4-3 Installing Data Carriers | 71 |
| SECTION 5 | |
| Communications with Hosts | 83 |
| 5-1 Introduction | 84 |
| 5-2 V600-HAR91/-HAR81 Intelligent Flag 8-bit Amplifier for Read Data Output | 84 |
| 5-3 V600-HAM91/-HAM81 Intelligent Flag 8-bit Amplifier with Versatile Functions | 88 |
| 5-4 V600-HAR92 Intelligent Flag II 16-bit Amplifier for Read Data Output | 99 |
| 5-5 Sample Programming for Host | 108 |
| SECTION 6 | |
| Chemical Resistance | 111 |
| 6-1 V600-HS51, V600-HS61, and V600-HS63 Sensors | 112 |
| 6-2 Data Carriers | 113 |
| Appendix | |
| Optional Accessories | 117 |
| Index | 119 |
| Revision History | 121 |

About this Manual:

This manual describes the installation and operation of the V600-series ID System Intelligent Flag and Intelligent Flag II and includes the sections described below.

Please read this manual carefully and be sure you understand the information provided before attempting to install and operate the V600-series ID System Intelligent Flag and Intelligent Flag II.

Section 1 provides a general introduction to the V600-series ID System Intelligent Flag and Intelligent Flag II, including the features and system configuration.

Section 2 provides the specifications and performance details for Amplifier Sections, Sensor Sections, and Data Carriers.

Section 3 provides the transmission specifications, including transmission distances and transmission times.

Section 4 provides installation instructions for Amplifier Sections, Sensor Sections, and Data Carriers.

Section 5 provides details of communications with hosts, including timing charts and operation outlines for each Intelligent Flag Amplifier which communicates with a host.

Section 6 provides information on the chemical resistance of Sensor Sections and Data Carriers.

The **Appendix** provides a list of optional accessories.



WARNING Failure to read and understand the information provided in this manual may result in personal injury or death, damage to the product, or product failure. Please read each section in its entirety and be sure you understand the information provided in the section and related sections before attempting any of the procedures or operations given.

SECTION 1

Features and System Configuration

This section provides a general introduction to the V600-series ID Systems Intelligent Flag and Intelligent Flag II, including the features and system configuration.

| | | |
|-----|------------------------------------|---|
| 1-1 | Features | 2 |
| 1-2 | Models | 3 |
| 1-3 | System Configuration | 4 |
| 1-4 | Overview of System Operation | 6 |

1-1 Features

The Intelligent Flag and Intelligent Flag II provide innovative electronic ID flags which replace conventional mechanical flags and Kanbans and also improve quality control and production process control systems.

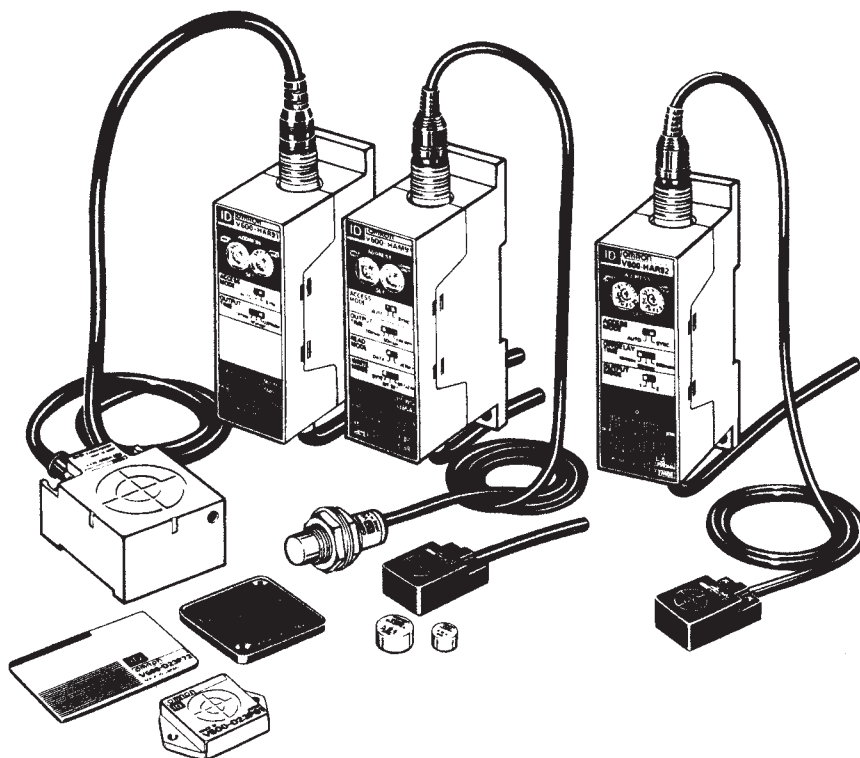

- | | |
|--|---|
| As Easy to Use As a Sensor | The operating mode and transmission parameters can be easily set using only the Amplifier setting switches. |
| Construct Advanced Production Lines with Minimum Investment | For conventional mechanical flags and Kanbans, it was necessary to prepare a flag for each model to be identified (e.g., 256 flags for 256 models). With the Intelligent Flag and Intelligent Flag II, however, one Data Carrier is enough to identify approximately 64,000 different models. |
| Space Saving | A single read/write head is equivalent to either or sixteen sensors. Accordingly, the space required for flags or Kanbans can be greatly reduced because there only one Data Carrier is required. |
| No Precise Positioning, No Problems with Mechanical Life or Mechanical Failures | A transmission distance of 65 mm eliminates the need for accurate position, as is necessary for unlike conventional sensors. The system also does not cause any mutual interference. And since the Intelligent Flag and Intelligent Flag II have no mechanical parts, such as the cylinders used in conventional mechanical flags, there is no need to worry about their service life or mechanical failures. |
| Wiring-saving Mode and Output Line Parity Checks | The Intelligent Flag II provides a wiring-saving mode in which communications can be controlled with a 16-point Input Unit. It also has a parity-check for outputs, which can find disconnected cables or faulty connections. |
| Compatible with Other OMRON FA ID Systems | The Intelligent Flag and Intelligent Flag II are compatible with V600-series Data Carriers, so they can be used to expand an existing production line. |

1-2 Models

The Intelligent Flag and Intelligent Flag II Amplifiers are shown below. Select the model best suited for your needs.

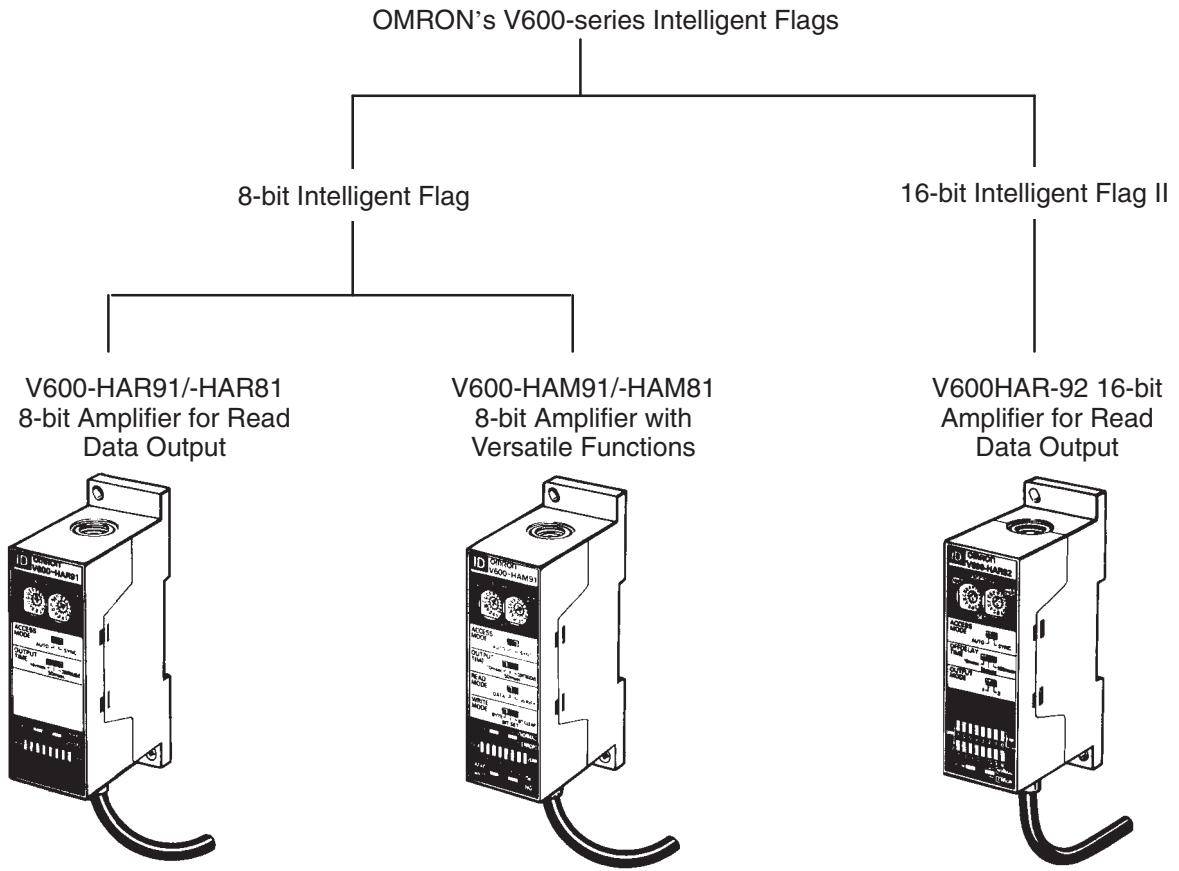

1-3 System Configuration

The Intelligent Flag and Intelligent Flag II can be combined with PCs and wiring-saving devices through open-collector I/O connections.

The Amplifier and Sensor can be connected with snap-on connectors, and the Amplifier and an Interface Cable can be connected with connectors. The Interface Cable can be extended up to 10 m.

All V600-series Data Carriers can be used.

V600-HAR91/-HAR81 and V600-HAM91/-HAM81 Amplifiers

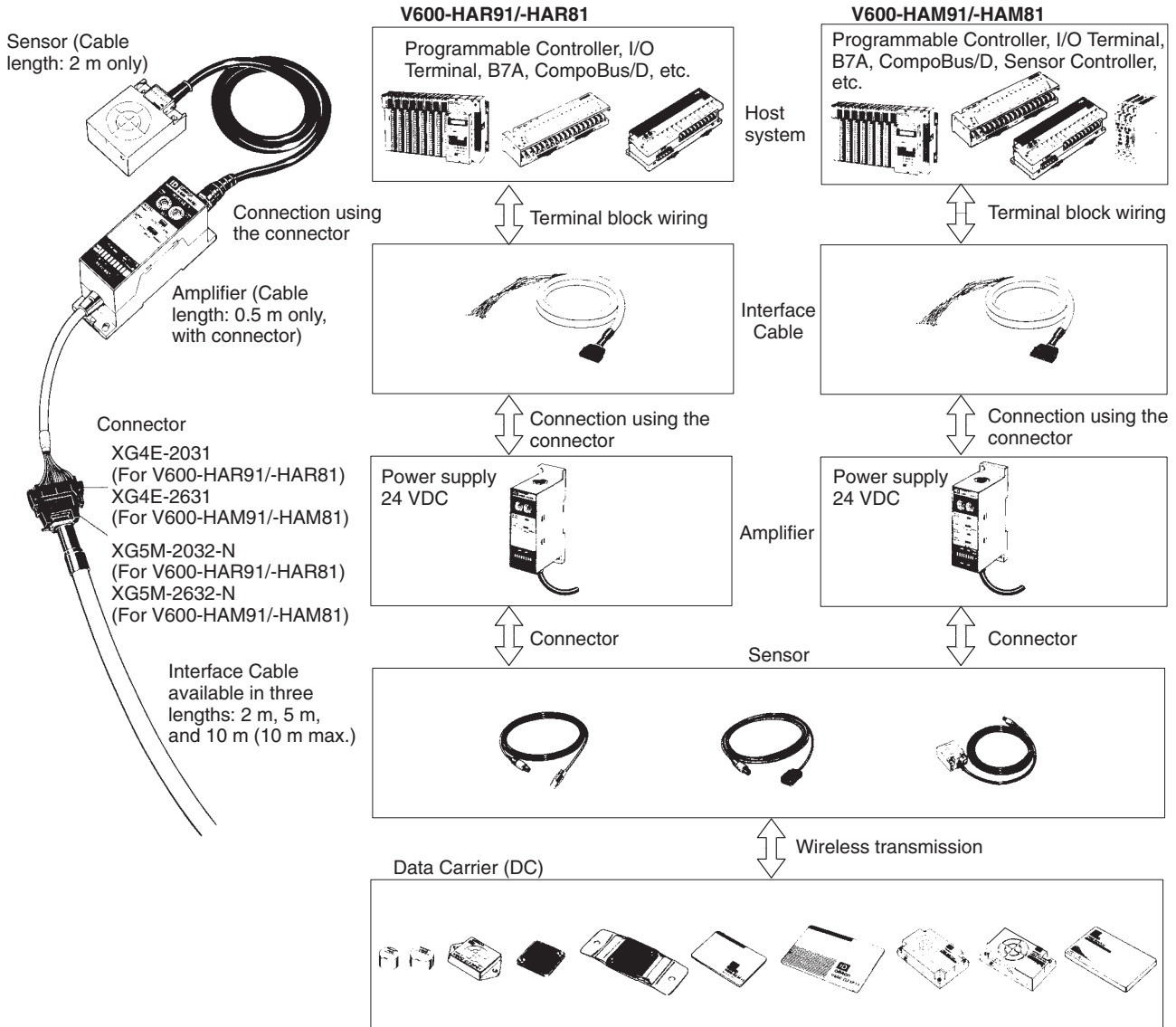

V600-HAR92 Intelligent Flag II Amplifier

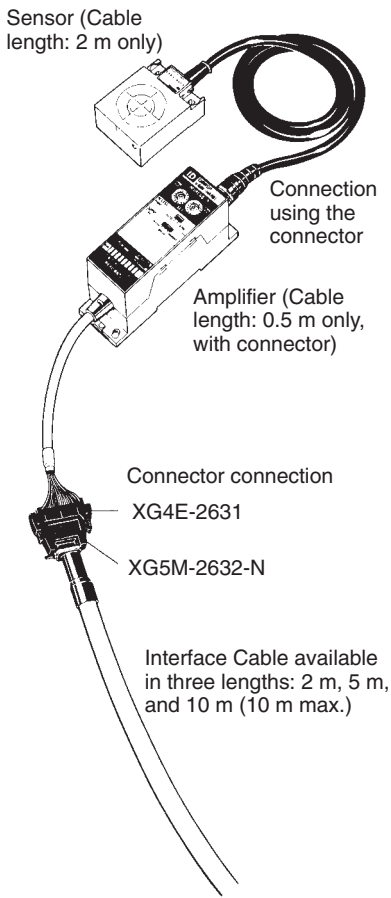

Host System

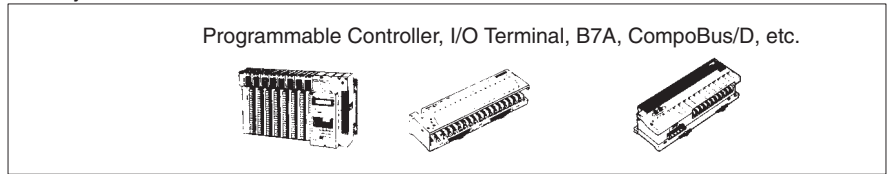

Terminal block wiring

Interface Cable

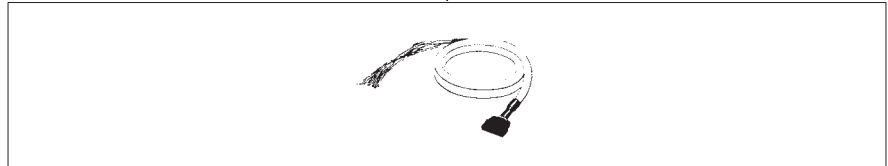

Connection using the connector

Amplifier



Connector

Sensor



Wireless transmission

Data Carrier (DC)

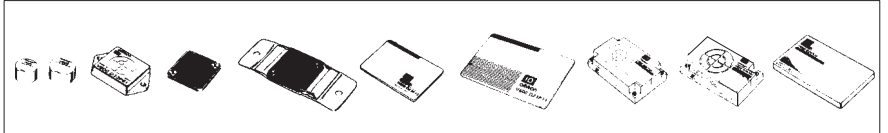

1-4 Overview of System Operation

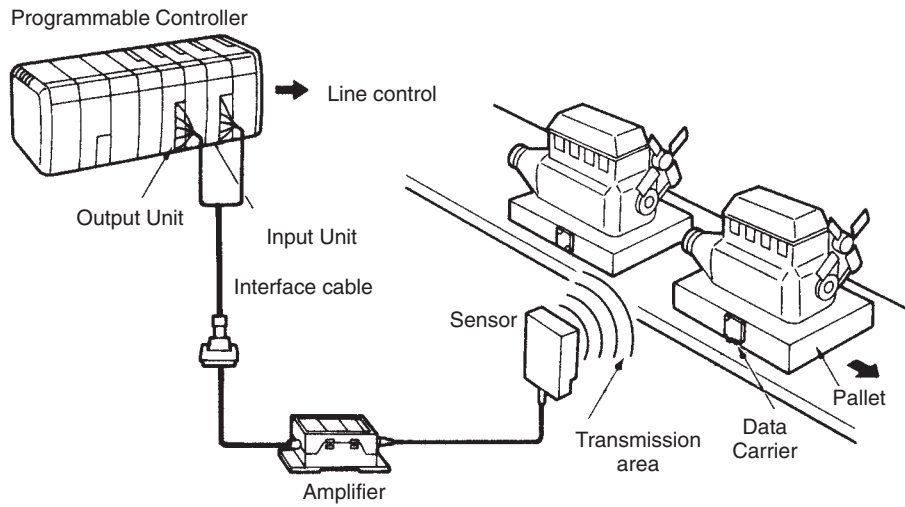

- 1, 2, 3...**
1. The host system, such as a PC, issues a request to the Amplifier to read or write 8-bit or 16-bit data from or to the Data Carrier.
 2. When the Data Carrier mounted on a pallet comes into the transmission area of the Sensor, 8-bit or 16-bit data is read from or written to the specified address in the Data Carrier.
 3. When data is read, it is sent from the Amplifier to the host system. The read data is output in parallel as ON/OFF (1/0) signals. When data is written, the result of the write processing (i.e., whether the write was successfully completed or not) is sent to the host.
 4. On receiving the result, the host system performs production line control and other tasks.

SECTION 2

Specifications and Performance

This section provides the specifications and performance details for Amplifiers, Sensors, and Data Carriers.

| | | |
|-------|--|----|
| 2-1 | Amplifier | 8 |
| 2-1-1 | Names and Functions of Each Part | 8 |
| 2-1-2 | General Specifications | 26 |
| 2-1-3 | I/O Specifications | 28 |
| 2-1-4 | Dimensions | 34 |
| 2-2 | Sensors | 37 |
| 2-2-1 | Specifications | 37 |
| 2-2-2 | Dimensions | 38 |
| 2-3 | EEPROM Data Carriers | 39 |
| 2-3-1 | Specifications and Dimensions | 39 |
| 2-3-2 | Memory Map | 43 |
| 2-3-3 | Write-protection | 44 |
| 2-4 | SRAM Data Carriers | 45 |
| 2-4-1 | Specifications and Dimensions | 45 |
| 2-4-2 | Memory Map | 48 |
| 2-4-3 | Write-protection | 49 |
| 2-4-4 | Battery Life | 50 |

2-1 Amplifier

2-1-1 Names and Functions of Each Part

V600-HAR91/-HAR81 Intelligent Flag 8-bit Read-out Amplifier

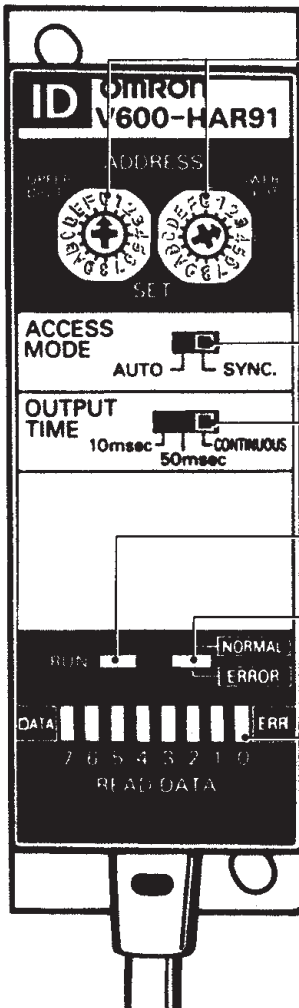

Address Switches

Used to set the read address in hexadecimal notation (0000_H to 00FF_H).

Left switch: Used to set the upper digit.

Right switch: Used to set the lower digit.

Example: To specify address 002A_H, set the left switch to 2 and the right switch to A. (The switch settings can be changed while the power is on.)

Access Mode Switch

Used to set the transmission mode for the Data Carrier.

This switch can be set to AUTO or SYNC (synchronous) mode.

(The switch setting is read only once when the power is turned on. It cannot be changed while the power is on.)

Output Time Switch

Used to set the output time to 10 ms, 50 ms, or CONTINUOUS (infinite).

(The switch setting is read only once when the power is turned on. It cannot be changed while the power is on.)

RUN Indicator

Green: Remains lit after the power is turned on (goes out when a hardware failure occurs).

Communications Termination Indicator (two-color LED)

Green: Lit when communications are terminated normally.

Red: Lit when communications are terminated erroneously.

Data Indicators (Two-color LEDs x 8)

Green: Displays read data in bit units.

Red: Flashes an error code at error termination.

Note The following two switches are to be set only when the power is turned on. The switch settings cannot be changed while the power is on. To change the switch settings, turn the power off, then reset the switches.

- Access mode switch
- Output time switch

Address Switches

To set the address of data.

- 1, 2, 3... 1. These switches are used to set the address of the data to be accessed (or read) in the Data Carrier.
2. The left switch is used to set the upper digit of the address, and the right switch is used to set the lower digit of the address.

Example:

To specify address 005B_H, set the left switch to 5 and the right switch to B.

3. Any address between 0000_H and 00FF_H, inclusive, can be specified.

SRAM Data Carriers: 0000_H to 00FF_H

EEPROM Data Carriers: 0000_H to 00FD_H

Access Mode Switch

To set the mode for accessing Data Carriers. There are two access modes: AUTO and SYNC.

1, 2, 3... 1. AUTO Mode

The AUTO mode is used mainly to access the Data Carrier while it is moving within the transmission area.

In AUTO mode, the V600-HAR91/-HAR81 Amplifier can always access Data Carriers after the power switch is turned on. The V600-HAR91/-HAR81 requires no trigger input for synchronization, and automatically accesses the Data Carrier when a Data Carrier enters the transmission area. Read data is sent to the data output lines. If the Data Carrier stays within the transmission area after the data has been read, the V600-HAR91/-HAR81 will not access the Data Carrier again. When the Data Carrier moves out of the transmission area or when the operation is stopped by the INHIBIT input signal and then released, the V600-HAR91/-HAR81 will return to the auto-read status.

Example: Using AUTO mode

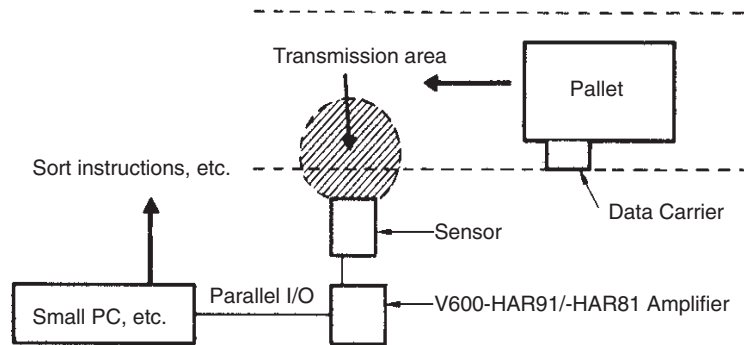

2. SYNC (Synchronous) Mode:

The SYNC mode is used mainly to access the Data Carrier when it stops within the transmission area.

In SYNC mode, the V600-HAR91/-HAR81 Amplifier will wait for input of a trigger when the power switch is turned ON. When the trigger input signal is turned ON, the V600-HAR91/-HAR81 immediately attempts read access. If a Data Carrier is in the transmission area, read data will be output to the data output lines. If no Data Carrier is in the transmission area, the V600-HAR91/-HAR81 will treat this as a “No Data Carrier” error and will output an error output signal for the time specified by the output time switch. If an error occurs, all data output lines will be set to OFF (0).

Example: Using SYNC mode

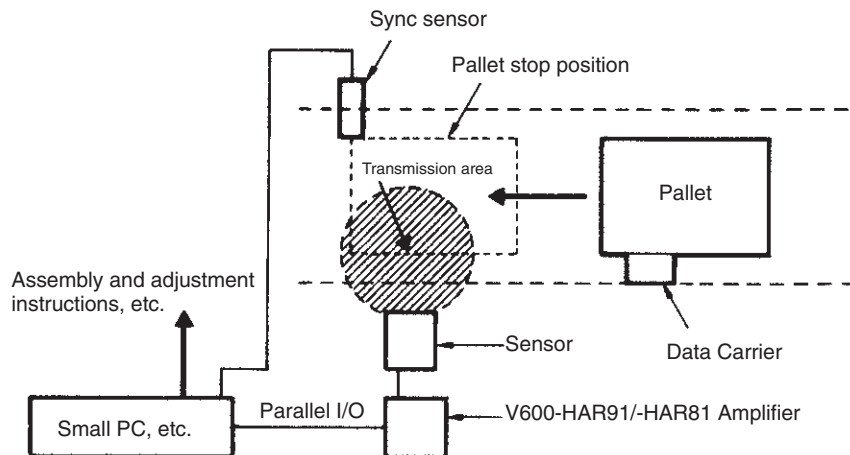

Output Time Switch

To set the output time.

This switch is used to set the output time for the normal termination output (NORMAL) and error termination output ($\overline{\text{ERR}}$) signals. If the switch is set to CONTINUOUS (infinite), these output signals are released when the INHIBIT input signal (for AUTO mode) or the TRG input signal (for SYNC mode) is turned ON.

Data Indicators (Two-color LEDs x 8)

To display read data and error codes.

1, 2, 3...

1. The 8-bit read data is displayed on the green LED indicators. They are associated with the data output lines, and remain lit until the next data is read.
2. If an error occurs, the indicators flash in red to indicate the error code. Flashing continues until the next read operation is performed. Refer to the following table for details on error codes.

Error Codes

| Flashing bit (indicator) | Name | Description | Required action |
|--------------------------|---------------------------------|---|---|
| 7 | Hardware error | CPU error due to excessive noise. | Turn the power off, and then on. |
| | Faulty switch setting | The switch is set halfway between the settings. | Set the switch correctly, and turn the power off, and then on. |
| 6 | External input error | The input state is unstable due to excessive noise. | Check the cause of noise (e.g., cable wiring). |
| | | The R/W switching line and data input lines are unstable. | Check the programs and interface specifications. |
| 5, 4 | Not used | Not used | Not used |
| 3 | Address error | The specified address is outside the memory area of the Data Carrier. | Check the address. |
| 2 | No Data Carrier | There was no Data Carrier in the transmission area when the trigger input signal was turned ON. | Check the trigger input timing. |
| | | | Check installation conditions, such as the transmission distance. |
| 1 | Not used | Not used | Not used |
| 0 | Data Carrier transmission error | Communications with the Data Carrier have not terminated correctly. | Check installation conditions, including the Data Carrier travel speed, transmission distance, etc. |

Functions

The V600-HAR91/-HAR81 is a read-only Amplifier. It reads 8-bit data from the specified address in the Data Carrier. There are two read modes: AUTO and SYNC. The access mode switch is used to select either of these modes.

AUTO Mode

- 1, 2, 3...**
1. The 8-bit data in the address specified by the address switches (two digits between 00_H and FF_H) is read from the Data Carrier. In AUTO mode, the V600-HAR91/-HAR81 automatically begins to access a Data Carrier when it enters the transmission area.
 2. Data read from the Data Carrier is output to the eight data output lines (OD0 to OD7). The data output lines remain as they are until new data is output at the next access.
 3. The NORMAL output signal is turned ON 3 ms after the data is output to the eight data output lines. The NORMAL output signal is output for the time specified by the output time switch.
 4. As mentioned above, the data output lines (OD0 to OD7) remain as they are until new data is output at the next access. These data output lines, however, can be forcibly set to OFF (0) by turning ON the INHIBIT input signal.
 5. When data fails to be read from the Data Carrier, the error output signal is turned ON for the time specified by the output time switch. If an error occurs, all the data output lines (OD0 to OD7) will be set to OFF (0).

SYNC Mode

- 1, 2, 3...**
1. The 8-bit data in the address specified by the address switches (two digits between 00_H and FF_H) is read from the Data Carrier. In SYNC mode, the V600-HAR91/-HAR81 begins to access a Data Carrier when a trigger input signal is turned ON while a Data Carrier is in the transmission area. Normally, a pallet stop signal is used as the trigger input signal.
 2. Data read from the Data Carrier is output to the eight data output lines (OD0 to OD7). The data output lines remain in the same state until the next trigger input signal is turned ON.
 3. The NORMAL output signal is turned ON 3 ms after the data is output to the eight data output lines. The NORMAL output signal is turned ON for the time specified by the output time switch.
 4. If the trigger input signal is turned ON when no Data Carrier is in the transmission area, a "No Data Carrier" error will occur and the error output signal is turned ON for the time specified by the output time switch. If an error occurs, all the data output lines (OD0 to OD7) are set to OFF (0).

V600-HAM91/-HAM81 Intelligent Flag 8-bit Multi-function Amplifier

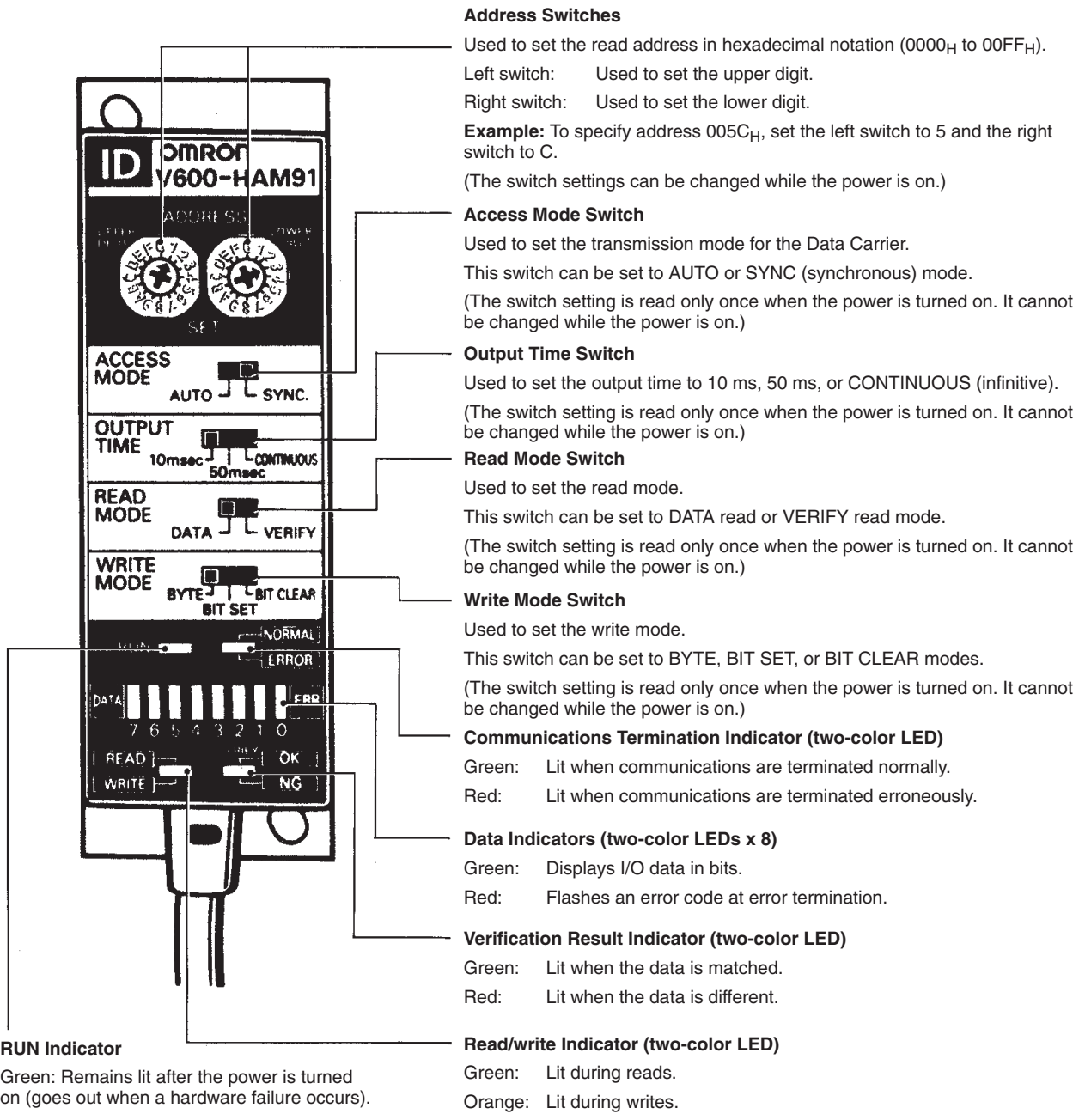

Address Switches
 Used to set the read address in hexadecimal notation (0000_H to 00FF_H).
 Left switch: Used to set the upper digit.
 Right switch: Used to set the lower digit.
Example: To specify address 005C_H, set the left switch to 5 and the right switch to C.
 (The switch settings can be changed while the power is on.)

Access Mode Switch
 Used to set the transmission mode for the Data Carrier.
 This switch can be set to AUTO or SYNC (synchronous) mode.
 (The switch setting is read only once when the power is turned on. It cannot be changed while the power is on.)

Output Time Switch
 Used to set the output time to 10 ms, 50 ms, or CONTINUOUS (infinite).
 (The switch setting is read only once when the power is turned on. It cannot be changed while the power is on.)

Read Mode Switch
 Used to set the read mode.
 This switch can be set to DATA read or VERIFY read mode.
 (The switch setting is read only once when the power is turned on. It cannot be changed while the power is on.)

Write Mode Switch
 Used to set the write mode.
 This switch can be set to BYTE, BIT SET, or BIT CLEAR modes.
 (The switch setting is read only once when the power is turned on. It cannot be changed while the power is on.)

Communications Termination Indicator (two-color LED)
 Green: Lit when communications are terminated normally.
 Red: Lit when communications are terminated erroneously.

Data Indicators (two-color LEDs x 8)
 Green: Displays I/O data in bits.
 Red: Flashes an error code at error termination.

Verification Result Indicator (two-color LED)
 Green: Lit when the data is matched.
 Red: Lit when the data is different.

Read/write Indicator (two-color LED)
 Green: Lit during reads.
 Orange: Lit during writes.

RUN Indicator
 Green: Remains lit after the power is turned on (goes out when a hardware failure occurs).

Note The following four switches are to be set only when the power is turned on. The switch settings cannot be changed while the power is on. To change the switch settings, turn the power off, then reset the switches.

- Access mode switch
- Output time switch
- Read mode switch
- Write mode switch

Address Switches

To set the address of data.

- 1, 2, 3... 1. These switches are used to set the address of the data to be accessed (or read) in the Data Carrier.
2. The left switch is used to set the upper digit of the address, and the right switch is used to set the lower digit of the address.

Example:

To specify address 00B9_H, set the left switch to B and the right switch to 9.

3. Any address between 0000_H and 00FF_H, inclusive, can be specified.
 SRAM Data Carriers: 0000_H to 00FF_H.
 EEPROM Data Carriers: 0000_H to 00FD_H

Access Mode Switch

The access mode switch sets the mode for accessing Data Carriers. There are two access modes: AUTO and SYNC.

1, 2, 3...

1. AUTO Mode:

AUTO mode is used mainly to access the Data Carrier while it is moving within the transmission area.

In AUTO mode, the V600-HAM91/-HAM81 can always access Data Carriers after the power switch is turned on. In this mode, the V600-HAM91/-HAM81 requires no trigger input for synchronization, and automatically accesses a Data Carrier when the Data Carrier enters the transmission area. If the Data Carrier stays within the transmission area after read or write access is complete, the V600-HAM91/-HAM81 will not access the Data Carrier again. When the Data Carrier moves out of the transmission area or when the operation is stopped by the INHIBIT input signal and then released, the V600-HAM91/-HAM81 returns to the Data Carrier waiting status.

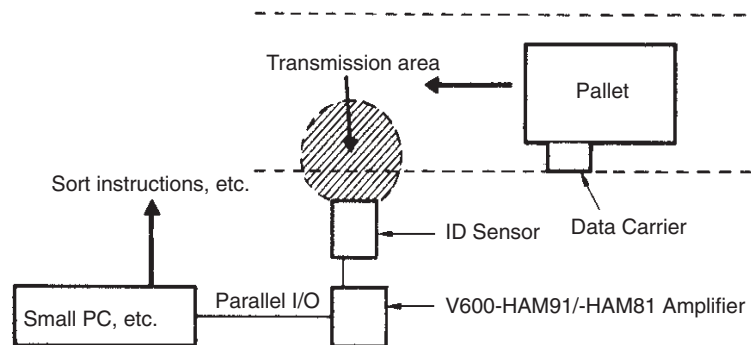
Example: Using AUTO mode**2. SYNC (Synchronous) Mode:**

SYNC mode is used mainly to stop and to access Data Carriers.

In SYNC mode, the V600-HAM91/-HAM81 Amplifier will wait for input of a trigger when the power switch is turned ON. When the trigger input signal is turned ON, the V600-HAM91/-HAM81 immediately will attempt read or write access. If a Data Carrier is in the transmission area, the result of the processing will be output. If no Data Carrier is in the transmission area, the V600-HAM91/-HAM81 will treat this as a "No Data Carrier" error and outputs an error output signal for the time specified by the output time switch. If an error occurs, all data output lines will be set to OFF (0).

Example: Using SYNC Mode

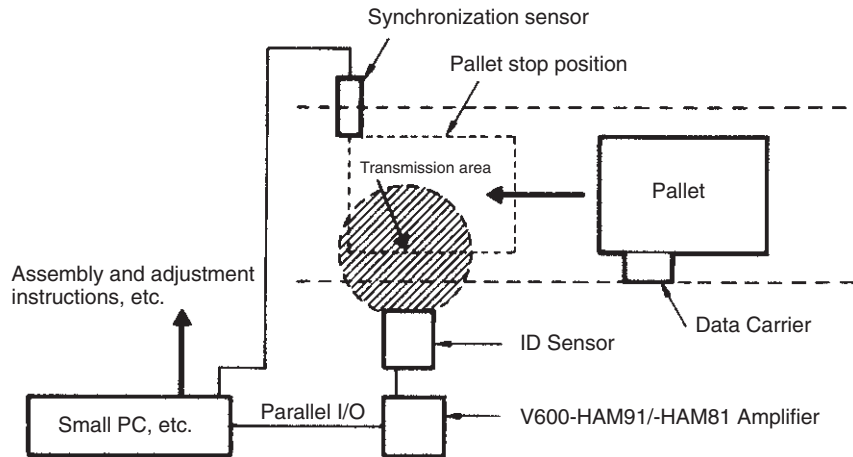

Output Time Switch

To set the output time.

This switch is used to set the output time for the normal termination output (NORMAL) and error termination output (\overline{ERR}) signals. If the switch is set to CONTINUOUS (infinite), these output signals are released when the INHIBIT input signal (for AUTO mode) or the TRG input signal (for SYNC mode) is turned ON.

Read Mode Switch

To set the read mode.

This switch is used to select DATA read or VERIFY read mode.

Write Mode Switch

To set the write mode.

This switch is used to select BYTE, BIT SET, or BIT CLEAR write mode.

Data Indicators (Two-color LEDs x 8)

To display read data, write data, verification results, and error codes.

1, 2, 3...

1. DATA Read Mode

Eight-bit read data is displayed (green LED indicators). These indicators remain lit until the next read processing is performed.

2. VERIFY Read Mode

The green indicators display the data for which VERIFY read processing has been performed. These indicators remain lit until the next read processing is performed.

3. Write Mode

The green indicators display the data for which write processing has been performed.

4. If an error occurs, the red indicators flash the error code. Flashing continues until the next read operation is performed. Refer to the following table for details of error codes.

Error Codes

| Flashing bit (indicator) | Name | Description | Required action |
|--------------------------|--|---|---|
| 7 | Hardware error | CPU error due to excessive noise. | Turn the power off, and then on. |
| | Faulty switch setting | The switch is set halfway between the settings. | Set the switch correctly, and turn the power off, and then on. |
| 6 | External input error | The input state is unstable due to excessive noise. | Check the cause of noise (e.g., cable wiring). |
| | | The R/W switching line and data input lines are unstable. | Check the programs and interface specifications. |
| 5 | Not used | Not used | Not used |
| 4 | Write-protect error | An address in a write-protected area was specified. | Check the write-protected area or change the address. |
| 3 | Address error | The specified address is outside the memory area of the Data Carrier. | Check the address. |
| 2 | No Data Carrier | There was no Data Carrier in the transmission area when the trigger input signal was turned ON. | Check the trigger input timing. |
| | | | Check installation conditions, such as the transmission distance. |
| 1 | Mismatch error (for write processing only) | A verification read error occurred during write processing. | Check installation conditions, including the Data Carrier travel speed and transmission distance. |
| 0 | Data Carrier transmission error | Communications with the Data Carrier have not terminated correctly. | Check installation conditions, including the Data Carrier travel speed, transmission distance, etc. |

Functions

The V600-HAM91/-HAM81 Amplifier has both read and write functions.

There are two read modes: DATA read and VERIFY read. In DATA read mode, 8-bit data is read from the specified address in the Data Carrier. In VERIFY read mode, 8-bit data is read and compared with preset 8-bit data, and the processing result (matched or different) is output.

There are three write modes: BYTE, BIT SET, and BIT CLEAR. In BYTE mode, 8-bit (1-byte) data is written. In BIT SET mode, particular bits are turned ON (1). In BIT CLEAR mode, particular bits are turned OFF (0). This write function is the same as that of mechanical flags.

Read Function: Data Read Mode

- 1, 2, 3... 1. Eight-bit data in the address specified by the address switches (two digits between 00_H and FF_H inclusive) is read from the Data Carrier. The read data is output to eight data output lines (OD0 to OD7).
2. The NORMAL output signal is turned ON 3 ms after the data is output. It is turned ON for the time specified by the output time switch.
3. In SYNC mode, the data output lines (OD0 to OD7) remain as they are until the next trigger input signal is turned ON. In AUTO mode, the data output lines remain as they are until new data is output. However, these data output lines can be forcibly set to OFF (0) by turning ON the INHIBIT input signal.
4. When data fails to be read from the Data Carrier, the error output signal is turned ON for the time specified by the output time switch.

Read Function: VERIFY Read Mode

- 1, 2, 3... 1. Eight-bit data in the address specified by the address switches (two digits between 00_H and FF_H inclusive) is read from the Data Carrier. The read data is compared with the reference data in the eight data input lines (ID0 to ID7) and then output to one of the following data output lines for the time specified by the output time switch.
 - When data is matched: Bit 0 (data output line OD0) is turned ON.
 - When data is different: Bit 7 (data output line OD7) is turned ON. (OD1 to OD6 are not used.)

- When data fails to be read from the Data Carrier, the error output signal is turned ON for the time specified by the output time switch.

Write Function: BYTE Mode

Write processing verifies that data is correctly written to the Data Carrier and then outputs the normal termination signal, NORMAL.

- 1, 2, 3... Data entered in the data input lines (ID0 to ID7) is written to the address specified by the address switches (two digits between 00_H and FF_H).
- After write processing is complete, the normal termination output signal NORMAL is turned ON for the time specified by the output time switch.
- When data fails to be written to the Data Carrier, the error output signal is turned ON for the time specified by the output time switch.

Example: BYTE Mode

In this mode, the 1-byte (8-bit) data specified as write data is written to the Data Carrier.

| Current data | | Bit set data (in data input lines) | | Data after bit set write processing |
|--------------|---|------------------------------------|---|-------------------------------------|
| 0 | | 1 | | 1 |
| 1 | | 1 | | 1 |
| 0 | | 0 | | 0 |
| 1 | ⇒ | 0 | ⇒ | 0 |
| 0 | | 1 | | 1 |
| 1 | | 1 | | 1 |
| 0 | | 0 | | 0 |
| 1 | | 0 | | 0 |

Write Function: BIT SET Mode

Write processing verifies that data is correctly written to the Data Carrier and then outputs the normal termination signal NORMAL.

- 1, 2, 3... Only the bits set to ON in the data input lines are set to 1 in the address specified by the address switches (two digits between 00_H and FF_H). Other bits are not changed.
- After write processing is complete, the normal termination output signal NORMAL is turned ON for the time specified by the output time switch.
- When data fails to be written to the Data Carrier, the error output signal is turned ON for the time specified by the output time switch.

Example: BIT SET Mode

In this mode, only the bits set to 1 in write data are set to 1. The status of other bits is not changed.

| Current data | | Bit set data (in data input lines) | | Data after bit set write processing |
|--------------|---|------------------------------------|---|-------------------------------------|
| 0 | | 1 | | 1 |
| 1 | | 0 | | 1 |
| 0 | | 0 | | 0 |
| 1 | ⇒ | 0 | ⇒ | 1 |
| 0 | | 1 | | 1 |
| 1 | | 1 | | 1 |
| 0 | | 1 | | 1 |
| 1 | | 1 | | 1 |

Write Function: BIT CLR Mode

Write processing verifies that data is correctly written to the Data Carrier and then outputs the normal termination signal NORMAL.

- 1, 2, 3... Only the bits which are ON in the data input lines are cleared to 0 in the address specified by the address switches (two digits between 00_H and FF_H). Other bits are not changed.

2. After write processing is complete, the normal termination output signal NORMAL is turned ON for the time specified by the output time switch.
3. When data fails to be written to the Data Carrier, the error output signal is turned ON for the time specified by the output time switch.

Example: BIT CLR mode

In this mode, only the bits set to 1 in write data are set to 0. The status of other bits is not changed.

| Current data | | Bit set data (in data input lines) | | Data after bit set write processing |
|--------------|---|---------------------------------------|---|--|
| 0 | | 0 | | 0 |
| 1 | | 0 | | 1 |
| 0 | | 0 | | 0 |
| 1 | ⇒ | 0 | ⇒ | 1 |
| 0 | | 1 | | 0 |
| 1 | | 1 | | 0 |
| 0 | | 1 | | 0 |
| 1 | | 1 | | 0 |

Note Read and write processing is switched by the ON and OFF of the interface line W/R on the Interface Cable, not by turning a switch on and off.

V600-HAR92 Intelligent Flag: 16-bit Read-only Amplifier

Names of Components

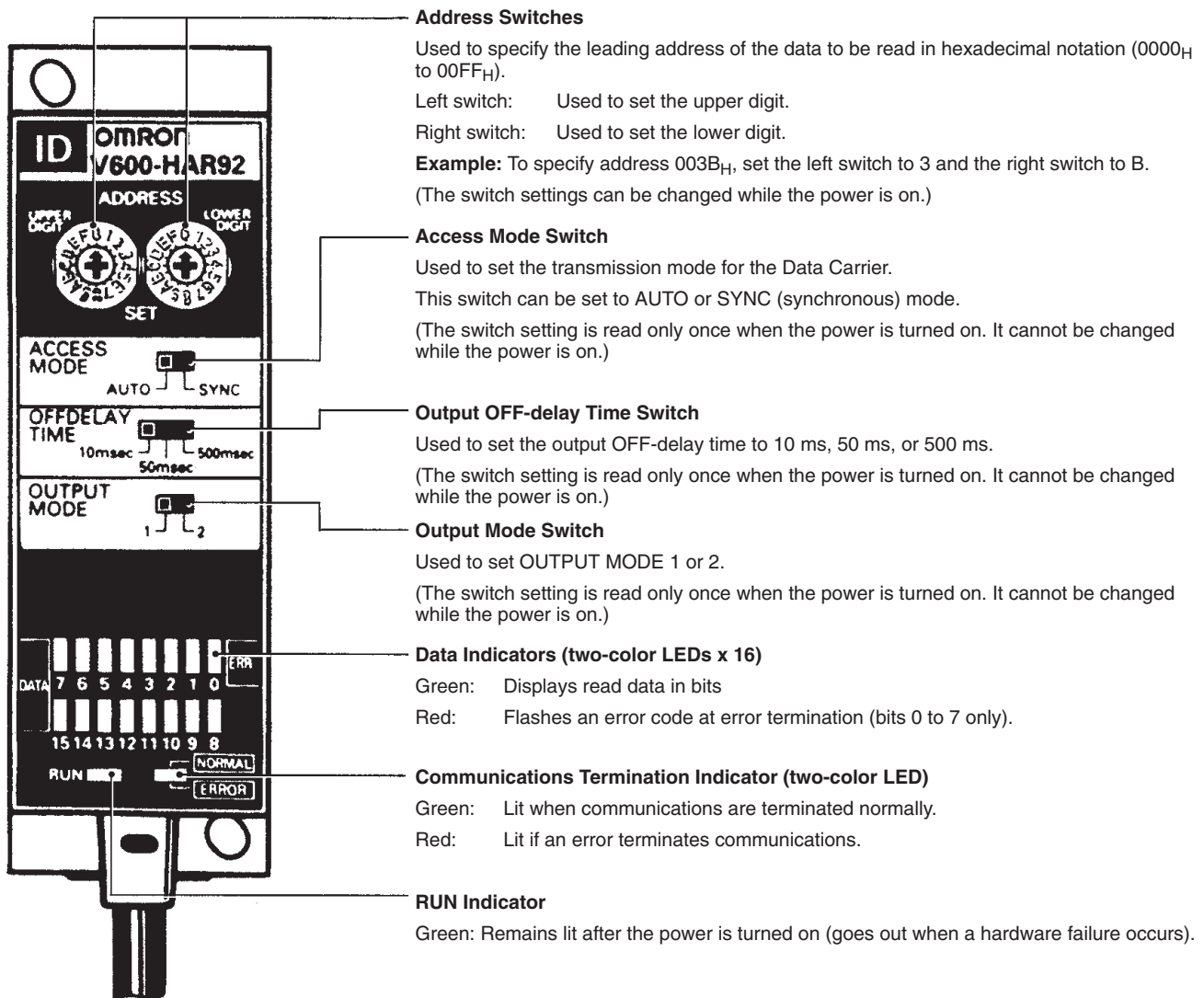

Note The following three switches are to be set only when the power is turned on. The switch settings cannot be changed while the power is on. To change the switch settings, turn the power off, then reset the switches.

- Access mode switch
- Output OFF-delay time switch
- Output mode switch

Address Switches

To set the address of data.

- 1, 2, 3... 1. These switches are used to specify the leading address of 16-bit (2-byte) data to be read from the Data Carrier.
Example:
 To read 16-bit (2-byte) data from addresses 0053_H and 0054_H, specify 0053_H as the leading address.
2. The left switch is used to set the upper digit of the address, and the right switch is used to set the lower digit of the address.
Example:
 To specify address 0053_H, set the left switch to 5 and the right switch to 3.

3. Any address between 0000_H and 00FF_H, inclusive, can be specified.
 SRAM Data Carriers: 0000_H to 00FF_H.
 EEPROM Data Carriers: 0000_H to 00FC_H

Access Mode Switch

To set the mode for accessing Data Carriers. There are two access modes: AUTO and SYNC.

1, 2, 3...

1. AUTO Mode:

AUTO mode is used mainly to access the Data Carrier while it is moving within the transmission area.

In AUTO mode, the V600-HAR92 Amplifier can always access Data Carriers after the power switch is turned on. The V600-HAR92 requires no trigger input for synchronization, and automatically accesses a Data Carrier when the Data Carrier enters the transmission area. Read data is sent to the data output lines.

If the Data Carrier stays within the transmission area after the data being read, the V600-HAR92 will not access the Data Carrier again. When the Data Carrier moves out of the transmission area or when the operation is stopped by the INHIBIT input signal and then released, the V600-HAR92 will return to the auto read status.

Example: Using AUTO mode

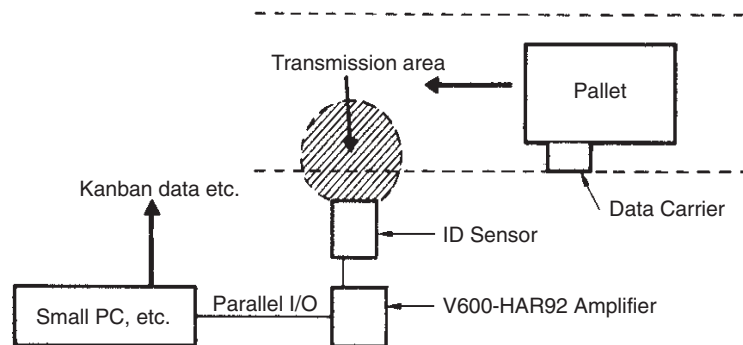

2. SYNC (Synchronous) Mode:

SYNC mode is used mainly to stop and access Data Carriers.

In SYNC mode, the V600-HAR92 Amplifier will wait for input of a trigger when the power switch is turned ON. When the trigger input signal is turned ON, the V600-HAR92 will immediately attempt read access. If a Data Carrier is in the transmission area, read data will be sent to the data output lines. If no Data Carrier is in the transmission area, the V600-HAR92 will treat this as a "No Data Carrier" error and will output an error output signal for the time specified by the output time switch.

Example: Using SYNC mode

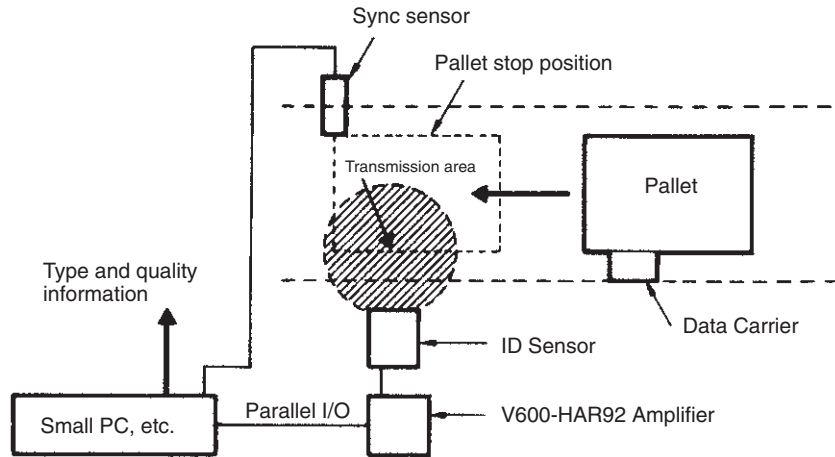

Output OFF-delay Time Switch

To set the output OFF-delay time.

This switch is used to specify the output OFF-delay times for the following data output signals:

- Data outputs OD0 to OD15 for both OUTPUT MODE 1 and OUTPUT MODE 2
- Normal termination output signal NORMAL in OUTPUT MODE 1
- Strobe output signal STRB for OUTPUT MODE 2
- Error output signal \overline{ERR} for both OUTPUT MODE 1 and OUTPUT MODE 2
- Parity-check output signal PARITY for OUTPUT MODE 1 and OUTPUT MODE 2

Regardless of the access mode, the output OFF-delay time (timer) starts when the Data Carrier moves out of the transmission area. Output data is forcibly cleared when an INHIBIT input signal is turned ON in AUTO mode or when the next trigger (TRG) input signal is turned ON in SYNC mode. Output data will be cleared even when the output OFF-delay time (timer) is active or a Data Carrier is in the transmission area.

! Caution The output methods for the Intelligent Flag and Intelligent Flag II Amplifier are different.

With the Intelligent Flag Amplifier, the output time for the data read from the Data Carrier is set to 10 ms, 50 ms, or CONTINUOUS. The read data is output for only the specified time regardless of whether the Data Carrier is in the transmission area.

With the Intelligent Flag II Amplifier, the output OFF-delay time for the data read from the Data Carrier is set to 10 ms, 50 ms, or 500 ms. The Intelligent Flag II Amplifier maintains the output data while the Data Carrier stays within the transmission area. Once the Data Carrier moves out of the transmission area, the output data is cleared after the specified output OFF-delay time.

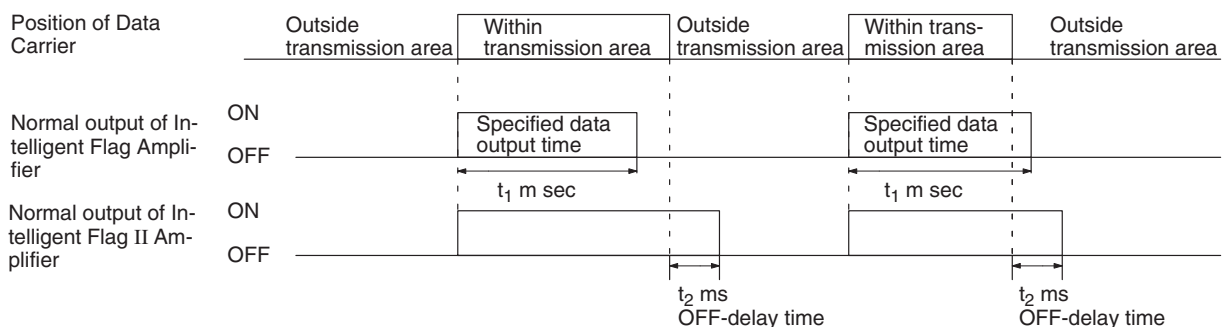

| | |
|--|--|
| Output Mode Switch | To set the output mode. |
| 1, 2, 3... | <ol style="list-style-type: none"> 1. OUTPUT MODE 1: Standard Mode In this mode, data reads, communications control, and error detection can be performed using 16 data output lines (OD0 to OD15), one normal termination output line (NORMAL), and one error termination output line (ERR). If one parity-check output line (PARITY) is connected, a communications parity check can be performed for the cable between the Input Unit for the host system unit and the Amplifier. If an error occurs in this mode, the corresponding error code for data output lines (OD0 to OD15) will be output in addition to the error termination output signal ERR. 2. OUTPUT MODE 2: Wiring Saving Mode In this mode, data reads, communications control, and error detection can be performed using only the 16 data output lines (OD0 to OD15). Control of, 16-bit (2-byte) data read processing is possible using only one 16-point Input Unit on a PC or wiring-saving device. In addition to these data output lines, one strobe output line (STRB) can be used to check the transmission termination status and one parity-check output line (PARITY) can be used to perform a communications parity check for the cables. Example: A total of 16 output lines, that is, 13 data output lines OD0 to OD12, one strobe output line STRB, one error termination output line ERR, and one parity-check output line PARITY, can be connected to the Input Unit for the host system unit. |
| Data Indicators (Two-color LEDs x 16) | To display the read data and error codes. |
| 1, 2, 3... | <ol style="list-style-type: none"> 1. The 16 green LED indicators display 16-bit read data in synchronization with the data output lines. All the data output lines are set to OFF (0) after the specified output OFF-delay time. The data indicators remain lit until the next read data is output. 2. The red indicators flash an error code in synchronization with the error output line if an error occurs. The indicators will continue to flash until the next read processing is performed. In OUTPUT MODE 1, the data output lines corresponding to the error code are turned ON. These data output lines are all set to OFF (0) after the specified output OFF-delay time. Refer to the following table for details on error codes. |

Error Codes

| Flashing bit (indicator) | Name | Description | Required action |
|--------------------------|--|---|---|
| 7 | Hardware error | CPU error due to excessive noise. | Turn the power off and then on. |
| | Faulty switch setting | The switch is set halfway between the settings. | Set the switch correctly, and turn the power off, and then on. |
| 6 | Not used | Not used | Not used |
| 5 | Hardware data error (for OUTPUT MODE 2 only) | Data in the specified address is set to all 0s or 1s. | Check the data in the specified address in the Data Carrier. |
| 4 | Not used | Not used | Not used |
| 3 | Address error | The specified address is outside the memory area of the Data Carrier. | Check the address. |
| 2 | No Data Carrier | There was no Data Carrier in the transmission area when the trigger input signal was turned ON. | Check the trigger input timing. |
| | | | Check installation conditions, such as the transmission distance. |
| 1 | Not used | Not used | Not used |
| 0 | Data Carrier transmission error | Communications with the Data Carrier have not terminated correctly. | Check installation conditions, including the Data Carrier travel speed, transmission distance, etc. |

Functions

The V600-HAR92 is a read-only Amplifier. It reads 16-bit (2-byte) data from the specified address in the Data Carrier.

There are two read modes: AUTO and SYNC, which can be specified with the access mode switch. Since a 16-point Input Unit is normally used on a PC or wiring-saving devices, the V600-HAR92 supports a wiring saving mode (OUTPUT MODE 2) as well as the standard mode (OUTPUT MODE 1) to allow communications to be controlled using just one 16-point Input Unit.

To ensure reliable communications between the Amplifier and the host system, the V600-HAR92 also provides a parity-check output line (PARITY), which allows easy detection of disconnections and other faults.

Read Function

There are two read modes: AUTO and SYNC, and they are basically the same as those of the V600-HAR91/-HAR81 Amplifier. The output time settings for the V600-HAR92 and V600-HAR91/-HAR81 Amplifiers, however, differ as shown in the following diagram.

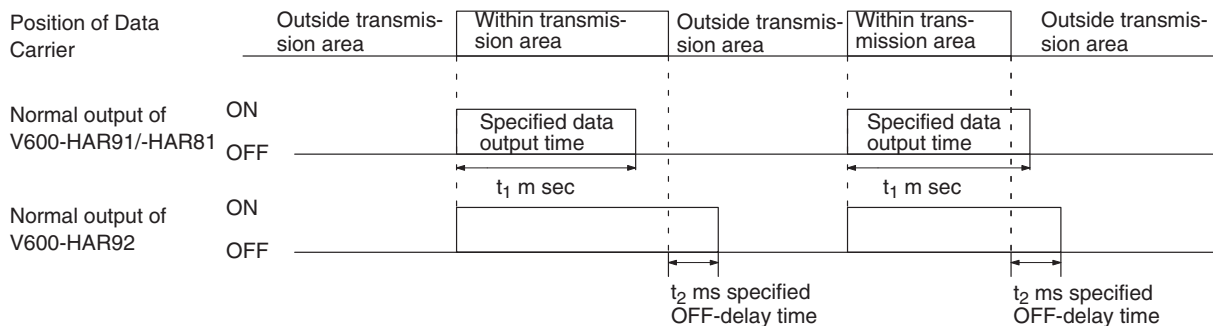

When the NORMAL output signal is turned OFF for the V600-HAR91/-HAR81, the data output lines remain as they are until the next read processing is performed. For the V600-HAR92, all the data output lines are set to OFF (0) when the NORMAL output signal is turned OFF.

Parity-check Output Function (PARITY)

The V600-HAR92 Amplifier provides one parity-check output line that is used to output the result of a parity check for the data that is output from the Amplifier to the host system through the cable. The parity-check output line allows easy checking for cable breakage or disconnection.

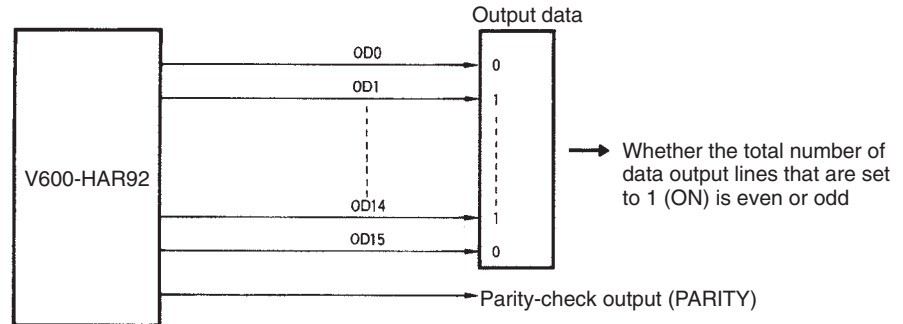

If the total number of data output lines that are set to 1 (ON) is even, the parity-check output line is turned OFF. If the total number is odd, the parity-check output line is turned ON.

Example:

If the total number of data output lines that are set to 1 (ON) is eight, the parity-check output line is turned OFF. If the total number is 11, the parity-check output line is turned ON.

Example of System Configurations

The following examples show combining of Input and Output Lines in Each Mode.

OUTPUT MODE 1: Standard Mode

Input Lines

INHIBIT (for AUTO mode) or TRG (for SYNC mode): 1 input

Output Lines

Data output (OD0 to OD15): 16 outputs

Normal termination output (NORMAL): 1 output

Error termination output (ERR): 1 output

Parity-check output (PARITY): 1 output

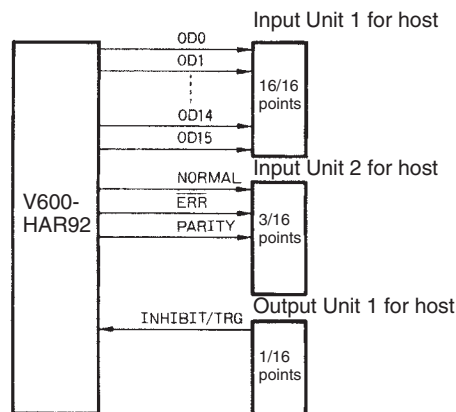

In OUTPUT MODE 1, the host system requires two 16-point Input Units and one Output Unit.

OUTPUT MODE 2: Wiring Saving Mode

Using 16 Outputs for Data

1, 2, 3...

1. AUTO Mode

Input Lines

INHIBIT (for AUTO mode): 1 input

Communications can also be controlled through 16 Data Output Lines without use of the INHIBIT input line.

Output Lines

Data output (OD0 to OD15): 16 outputs

Error termination output (\overline{ERR}): 1 output

Strobe output (STRB): 1 output

Parity-check output (PARITY): 1 output

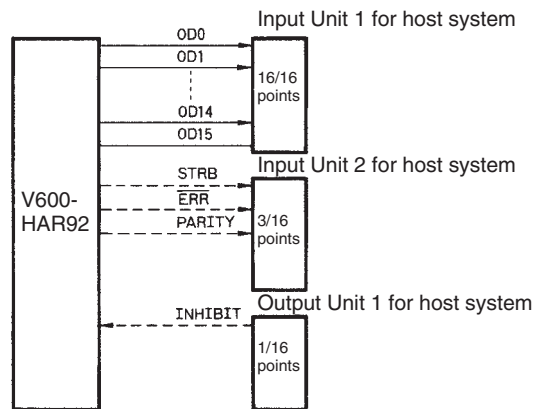

The V600-HAR92 Amplifier can be used by connecting only to Input Unit 1 of the host system. In this case, the all zeros (0000_H) data output bit string is used for communications control, and all 1s (FFFF_H) is used as an error code. These bit strings cannot be used as data. Therefore, only 0001_H to FFFE_H can be used as data.

2. SYNC Mode

Input Lines

TRG (for SYNC mode): 1 input

Output Lines

Data output (OD0 to OD15): 16 outputs

Error termination output (\overline{ERR}): 1 output

Strobe output (STRB): 1 output

Parity-check output (PARITY): 1 output

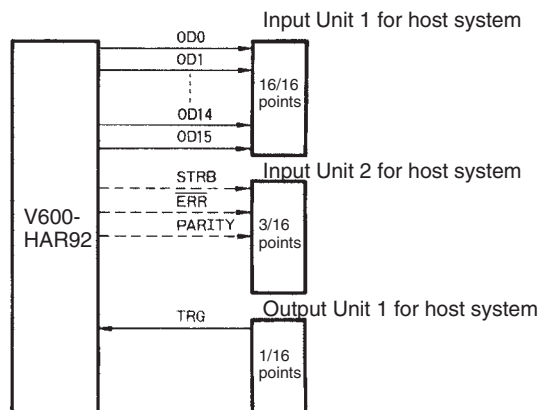

The V600-HAR92 Amplifier can be used by connecting only to Input Unit 1 of the host system. In this case, the all zeros (0000_H) data output bit string is

used for communications control, and all 1s (FFFF_H) is used as an error code. These bit strings cannot be used as data. Output Unit 1 for trigger is required.

Using 15 Outputs or Less for Data

- 1, 2, 3... 1. **AUTO Mode**
Example: Using 14 Outputs for Data

Input Lines

INHIBIT (for AUTO mode): 1 input

Communications can also be controlled without use of the INHIBIT input line.

Output Lines

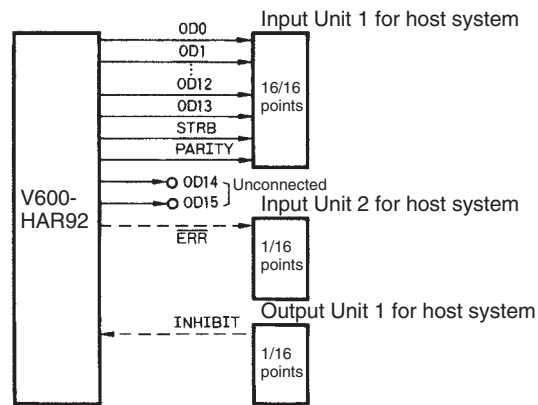

A total of 16 output lines, i.e., 14 data output lines, one strobe output line STRB, and one parity-check output line PARITY, can be connected to Input Unit 1 of the host system. In this case, 0001_H to 3FFF_H can be used as data.

- 2. **SYNC Mode**
Example: Using 13 Outputs for Data

Input Lines

TRG (for SYNC mode): 1 input

Output Lines

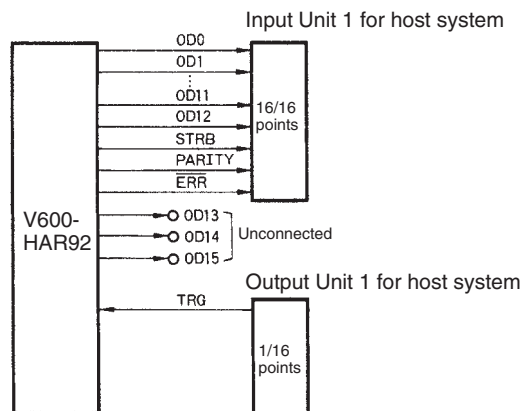

A total of 16 output lines, i.e., 13 data output lines, one strobe output line STRB, and one parity-check output line PARITY, can be connected to Input Unit 1 of the host system. In this case, 0001_H to 1FFF_H can be used as data. Output Unit 1 for trigger is required.

Function List

| Function | | V600-HAR91/ -HAR81 | V600-HAM91/ -HAM81 | V600-HAR92 |
|---|--------------------------------------|-----------------------|-----------------------|-------------|
| Reading data | 8 bits | Available | Available | (Available) |
| | 16 bits | | | Available |
| Writing data | 8-bit unit (1 byte) | | Available | |
| | 1-bit unit (Bit set or bit clear) | | Available | |
| Verifying read data against preset data | | | Available | |
| Parity check for data output lines | | | | Available |
| Wiring saving mode | | | | Available |

2-1-2 General Specifications

Intelligent Flag V600-HAR91/-HAR81 and V600-HAM91/-HAM81 Amplifiers

| Item | Read-only Amplifiers | | Multi-function Amplifiers | |
|------------------------------|--|---|---|---|
| | V600-HAR91 | V600-HAR81 | V600-HAM91 | V600-HAM81 |
| Power supply | 24 VDC \pm 10%, ripple (p-p): 10% | | | |
| Current consumption | 130 mA max. | | | |
| Input | Transistor output or contact output Short-circuit current: 3 mA (typical) (IN terminal and 0-V short-circuit) OFF voltage: 15 to 30 VDC ON voltage: 0 to 5 VDC Input impedance: 8.2 k Ω Applied voltage: 30 VDC max. | | | |
| Output | NPN open collector, 20 mA max. at 30 VDC, residual voltage: 2 V max. | PNP open collector, 20 mA max. at 30 VDC, residual voltage: 2 V max. | NPN open collector, 20 mA max. at 30 VDC, residual voltage: 2 V max. | PNP open collector, 20 mA max. at 30 VDC, residual voltage: 2 V max. |
| Diagnostic functions | Checks for CPU errors and transmission errors | | | |
| Insulation resistance | 50 M Ω min. (at 500 VDC) between cable terminals and case | | | |
| Dielectric strength | 500 VAC, 50/60 Hz for 1 min between cable terminals and case | | | |
| Vibration resistance | Destruction: 10 to 150 Hz, 0.3 mm double amplitude, with 4 sweeps of 8 min each in 3 directions | | | |
| Shock resistance | Destruction: 294 m/s ² (approx. 30G), 3 times each in 6 directions | | | |
| Ambient temperature | Operating: -10°C to 55°C (with no icing) Storage: -25°C to 65°C | | | |
| Ambient humidity | Operating: 35% to 85% (with no condensation) | | | |
| Enclosure rating | IP40 | | | |
| Ground | Ground to 100 Ω or less. | | | |
| Material | ABS resin (case) | | | |
| Cable length | Standard, 0.5 m with a special connector (see note) | | | |
| Weight | Approx. 170 g | | | |

Note The connector is not waterproof. If necessary, place the connector inside the control box to prevent exposed to water. Use the connector together with the following Interface Cables (sold separately).

Interface Cables

| Amplifier | Cable length | Interface Cable |
|--|--------------|-----------------|
| V600-HAR91/-HAR81 (Connector: 20 pin) | 2m | V600-A60R |
| | 5m | V600-A61R |
| | 10m | V600-A62R |
| V600-HAM91/-HAM81 (Connector: 26 pin) | 2m | V600-A60M |
| | 5m | V600-A61M |
| | 10m | V600-A62M |

Note The extension cable connector is not waterproof. If necessary, place the connector inside the control box to prevent exposed to water. The maximum cable length is 10 m.

V600-HAR92 Intelligent Flag II Amplifier

| Item | V600-HAR92 |
|------------------------------|---|
| Power supply | 24 VDC \pm 10%, ripple (p-p): 10% |
| Current consumption | 130 mA max. |
| Input | Transistor output or contact output Short-circuit current: 3 mA (typical) (INHIBIT/TRG terminal and 0-V short-circuit) OFF voltage: 15 to 30 VDC ON voltage: 0 to 5 VDC Input impedance: 8.2 k Ω Applied voltage: 30 VDC max. |
| Output | NPN open collector, 20 mA max. at 30 VDC, residual voltage: 2 V max. |
| Diagnostic functions | Checks for CPU errors and transmission errors |
| Insulation resistance | 50 M Ω min. (at 500 VDC) between cable terminals and case |
| Dielectric strength | 500 VAC, 50/60 Hz for 1 min between cable terminals and case |
| Vibration resistance | Destruction: 10 to 150 Hz, 1.5 mm double amplitude, with 4 sweeps of 8 min each in 3 directions |
| Shock resistance | Destruction: 294 m/s ² (approx. 30G), 3 times each in 6 directions |
| Ambient temperature | Operating: -10°C to 55°C (with no icing) Storage: -25°C to 65°C |
| Ambient humidity | Operating: 35% to 85% (with no condensation) |
| Enclosure rating | IP40 |
| Ground | Ground to 100 Ω or less. |
| Material | ABS resin (case) |
| Cable length | Standard, 0.5 m with a special connector (see note) |
| Weight | Approx. 180 g |

Note The connector is not waterproof. If necessary, place the connector inside the control box to prevent exposed to water. Use the connector together with the following Interface Cables (sold separately).

Interface Cables

| Cable length | Interface Cable |
|--------------|-----------------|
| 2m | V600-A60M |
| 5m | V600-A61M |
| 10m | V600-A62M |

Note The extension cable connector is not waterproof. If necessary, place the connector inside the control box to prevent exposed to water. The maximum cable length is 10 m.

2-1-3 I/O Specifications

Intelligent Flag V600-HAR91/-HAR81 Amplifier

I/O Circuit Diagram

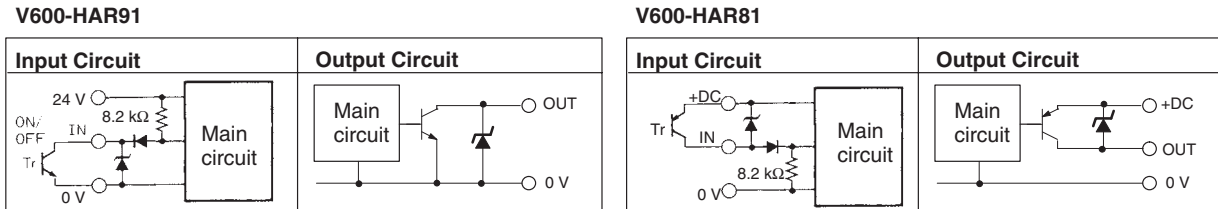

Interface Connectors

| | |
|---|-------------------------------------|
| Connector on V600-HAR91/-HAR81 end | Connector on host system end |
| XG4E-2031 (OMRON) | XG5M-2032-N (OMRON) |

- Note**
1. These connectors are not waterproof.
 2. The V600-HAR91/-HAR81 cable is provided with a special connector. To extend this cable, always use a special Interface Cable or the XG5M-2032-N Connector shown above.

Connector Pin Assignments

| Pin No. | Signal name | Lead wire color | Description |
|---------|--------------|-----------------|---|
| 1 | 0V | Blue | Power input line 24 VDC ±10% |
| 2 | 24 VDC | Brown | |
| 3 | INHIBIT/TRIG | Red | AUTO mode: Operation stop input, NORMAL and ERR release input SYNC mode: Access start trigger input |
| 4 | OD0 | Green | Read data output line: Bit 0 |
| 5 | OD1 | Yellow | Read data output line: Bit 1 |
| 6 | OD2 | White | Read data output line: Bit 2 |
| 7 | OD3 | Black | Read data output line: Bit 3 |
| 8 | OD4 | Gray | Read data output line: Bit 4 |
| 9 | OD5 | Orange | Read data output line: Bit 5 |
| 10 | OD6 | Light blue | Read data output line: Bit 6 |
| 11 | OD7 | Pink | Read data output line: Bit 7 |
| 12 | NORMAL | Light green | Normal output line |
| 13 | ERR | Violet | Error output line |
| 20 | FG | Shield | Ground to 100 Ω or less. |

- Note**
1. Only the error output line is active when the signal level is low (OFF). It is turned ON when the power is turned on. The error output line thus also serves as a RUN output line for power-on verification.
 2. For data input and output lines, ON and OFF mean 1 and 0, respectively.
 3. Pins 14 to 19 are not used.

Connector Pin Assignment Diagram

The following diagram illustrates the pin arrangement of the XG4E-2031 Connector on the V600-HAR91/-HAR81 end.

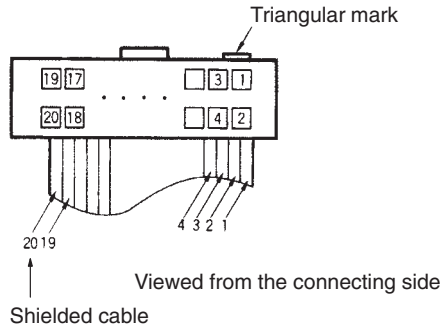

Intelligent Flag V600-HAM91/-HAM81 Amplifier

I/O Circuit Diagram

V600-HAM91

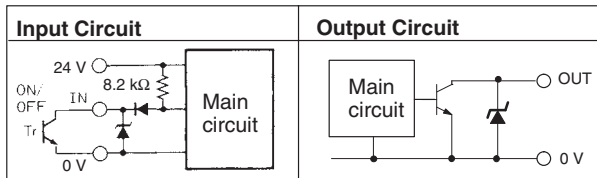

V600-HAM81

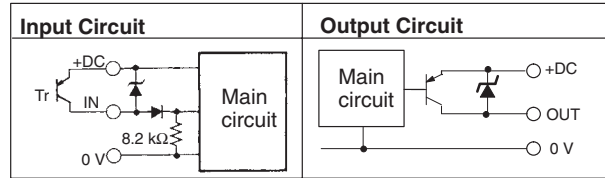

Interface Connectors

| Connector on V600-HAM91/-HAM81 end | Connector on host system end |
|------------------------------------|------------------------------|
| XG4E-2631 (OMRON) | XG5M-2632-N (OMRON) |

Note The V600-HAM91/-HAM81 cable is provided with a special connector. To extend this cable, always use a special Interface Cable or a XG5M-2632-N Connector as shown above.

Connector Pin Assignments

| Pin No. | Signal name | Lead wire color | Description |
|---------|-------------------------|-----------------|--|
| 1 | 0V | Blue | Power input |
| 2 | 24 VDC | Brown | Power input |
| 3 | INHIBIT/TRG | Red | Inhibit input (AUTO) |
| | | | Trigger input (SYNC) |
| 4 | OD0 | Green | Read data output bit 0 |
| | | | Matched output (VERIFY) |
| 5 | OD1 | Yellow | Read data output line: Bit 1 |
| 6 | OD2 | White | Read data output line: Bit 2 |
| 7 | OD3 | Black | Read data output line: Bit 3 |
| 8 | OD4 | Gray | Read data output line: Bit 4 |
| 9 | OD5 | Orange | Read data output line: Bit 5 |
| 10 | OD6 | Light blue | Read data output line: Bit 6 |
| 11 | OD7 | Pink | Read data output line: Bit 7 |
| | | | Different output (VERIFY) |
| 12 | NORMAL | Light green | Read normal termination output |
| | | | VERIFY read normal termination output (VERIFY) |
| | | | Write normal termination output |
| 13 | $\overline{\text{ERR}}$ | Violet | Error output (see note 2) |
| 14 | ID0 | White/black | Write data input bit 0 |
| | | | Verify data input bit 0 (VERIFY) |
| 15 | ID1 | White/red | Write data input bit 1 |
| | | | Verify data input bit 1 (VERIFY) |
| 16 | ID2 | White/green | Write data input bit 2 |
| | | | Verify data input bit 2 (VERIFY) |
| 17 | ID3 | White/yellow | Write data input bit 3 |
| | | | Verify data input bit 3 (VERIFY) |
| 18 | ID4 | White/brown | Write data input bit 4 |
| | | | Verify data input bit 4 (VERIFY) |
| 19 | ID5 | White/blue | Write data input bit 5 |
| | | | Verify data input bit 5 (VERIFY) |
| 20 | ID6 | White/orange | Write data input bit 6 |
| | | | Verify data input bit 6 (VERIFY) |
| 21 | ID7 | Gray/black | Write data input bit 7 |
| | | | Verify data input bit 7 (VERIFY) |
| 22 | W/R | Gray/white | R/W switching input OFF (open): R; ON: W |
| 23 | – | | Not used |
| 24 | – | | Not used |
| 25 | – | | Not used |
| 26 | FG | Shield | Ground to 100 Ω or less. |

- Note**
1. AUTO, SYNC, and VERIFY mean AUTO mode, SYNC (synchronous) mode, and VERIFY read mode, respectively.
 2. Only the error output line is active when the signal level is low (OFF). It is set to ON when the power is turned on. The error output line thus also serves as a RUN output line for power-on verification.
 3. For data input and output lines, ON and OFF mean 1 and 0, respectively.

Connector Pin Assignment Diagram

The following diagram illustrates the pin arrangement of the XG4E-2631 Connector on the V600-HAM91/-HAM81 end.

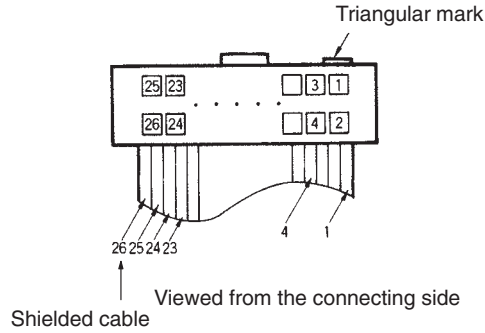

Intelligent Flag II V600-HAR92 Amplifier

I/O Circuit Diagram

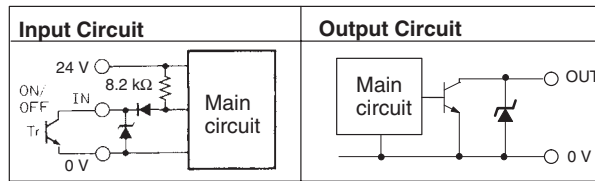

Interface Connectors

| Connector on V600-HAR92 end | Connector on host end |
|-----------------------------|-----------------------|
| XG4E-2631 (OMRON) | XG5M-2632-N (OMRON) |

Note The V600-HAR92 cable is provided with a special connector. To extend this cable, therefore, always use a special Interface Cable or a XG5M-2632-N Connector shown above.

Connector Pin Assignments

| Pin No. | Signal name | Lead wire color | Description |
|---------|-----------------|-----------------|---|
| 1 | 0V | Blue | Power input |
| 2 | 24 VDC | Brown | Power input |
| 3 | INHIBIT/TRG | Red | Inhibit input (AUTO) |
| | | | Trigger input (SYNC) |
| 4 | OD0 | Green | Read data output bit 0 |
| 5 | OD1 | Yellow | Read data output bit 1 |
| 6 | OD2 | White | Read data output bit 2 |
| 7 | OD3 | Black | Read data output bit 3 |
| 8 | OD4 | Gray | Read data output bit 4 |
| 9 | OD5 | Orange | Read data output bit 5 |
| 10 | OD6 | Light blue | Read data output bit 6 |
| 11 | OD7 | Pink | Read data output bit 7 |
| 12 | NORMAL/ STRB | Light green | Read normal termination output (for OUTPUT MODE 1) |
| | | | Strobe output (for OUTPUT MODE 2) |
| 13 | ERR | Violet | Error output (see note1.) |
| 14 | OD8 | White/black | Read data input bit 8 |
| 15 | OD9 | White/red | Read data input bit 9 |
| 16 | OD10 | White/green | Read data input bit 10 |
| 17 | OD11 | White/yellow | Read data input bit 11 |
| 18 | OD12 | White/brown | Read data input bit 12 |
| 19 | OD13 | White/blue | Read data input bit 13 |
| 20 | OD14 | White/orange | Read data input bit 14 |
| 21 | OD15 | Gray/black | Read data input bit 15 |
| 22 | PARITY | Gray/white | Parity-check output (OFF when even number, ON when odd number) |
| 23 | – | | Not used |
| 24 | – | | Not used |
| 25 | – | | Not used |
| 26 | FG | Shield | Ground to 100 Ω or less. |

- Note**
1. Only the error output line is active when the signal level is low (OFF). It is set to ON when the power is turned on. The error output line thus also serves as a RUN output line for power-on verification.
 2. For data input and output lines, ON and OFF mean 1 and 0, respectively.

Connector Pin Assignment Diagram

The following diagram illustrates the pin arrangement of the XG4E-2631 Connector on the V600-HAR92 end.

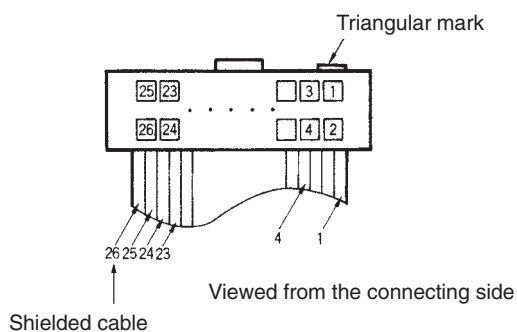

Precautions

Input/Output

The Data Input and Data Output lines are set to “1” when the transistor turns ON and to “0” when it turns OFF.

Do not use a solid-state output with the following ratings with the V600-HAM91/-HAM81 Amplifier. Using solid-state outputs with these rating can cause external input errors.

- Maximum switching current: 1 A or higher
- Minimum switching current: 10 mA or higher
- Response time (ON to OFF): 3 ms or higher

The following OMRON products cannot be connected to the V600-HA□91, V600-HA□81, or V600-HA□92 Amplifier Unit.

- CVM1-OD219 Output Unit
- C20H, C28H, C40H, or C60H Programmable Controllers
- Sensor Controllers other than from the S3D2 Series

When using a contact output, consider chattering and the minimum switching current.

When connecting an inductive load or an electrical device that tends to generate noise to the output, connect a diode in parallel with the load. Connect the cathode side of the diode to the positive side of the power supply.

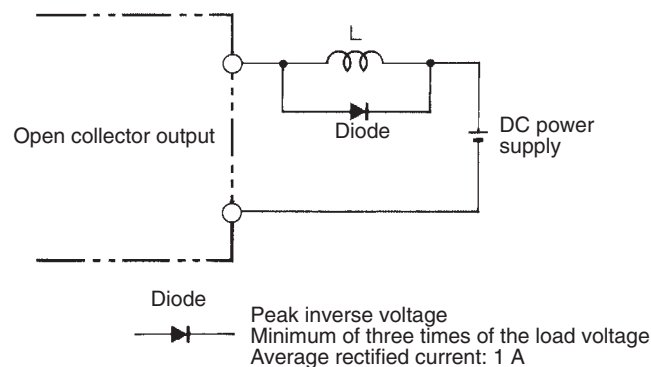

! WARNING Power Supply Voltage

Do not impose an AC (100 VAC) power supply or any voltage exceeding the rated voltage range on the V600-HA□91, V600-HA□81, or V600-HA□92 Amplifier. Unsuitable power supplies may cause the V600-HA□91, V600-HA□81, or V600-HA□92 to explode or burn.

! WARNING Load Short-circuiting

Do not short-circuit the load connected to the V600-HA□91, V600-HA□81, or V600-HA□92 Amplifier or connect power to the load. Any of these may cause the V600-HA□91, V600-HA□81, or V600-HA□92 to explode or burn.

! WARNING Wiring

Do not mis-wire and do not reverse the polarity of the power supply connected to the V600-HA□91, V600-HA□81, or V600-HA□92 Amplifier. Wiring mistakes, including reversed power supply polarity, may cause the V600-HA□91, V600-HA□81, or V600-HA□92 to explode or burn.

2-1-4 Dimensions

Intelligent Flag V600-HAR91/-HAR81 Amplifier

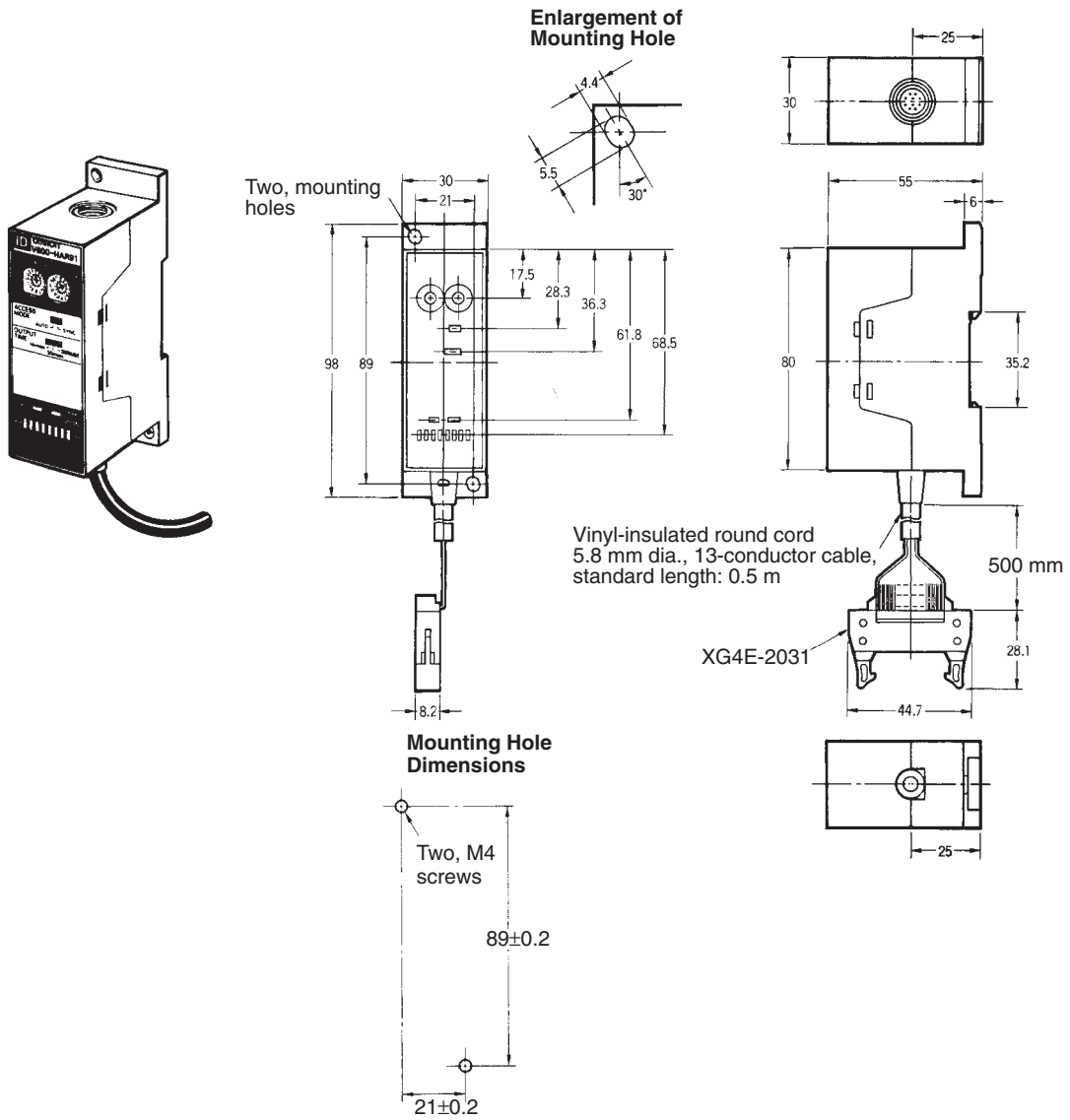

Intelligent Flag V600-HAM91/-HAM81 Amplifier

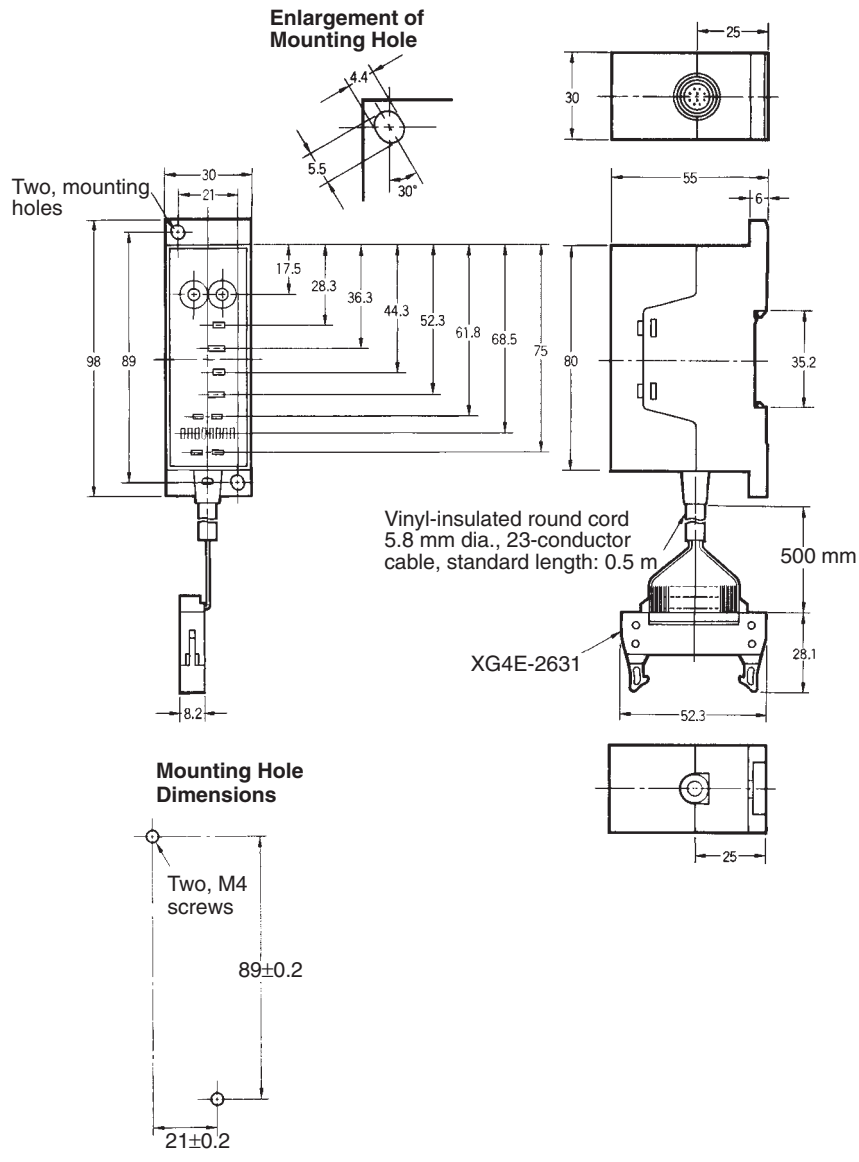
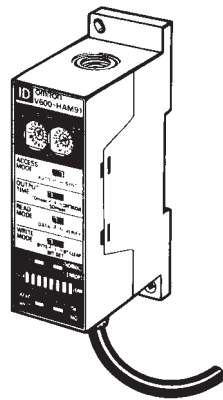

Intelligent Flag II V600-HAR92 Amplifier

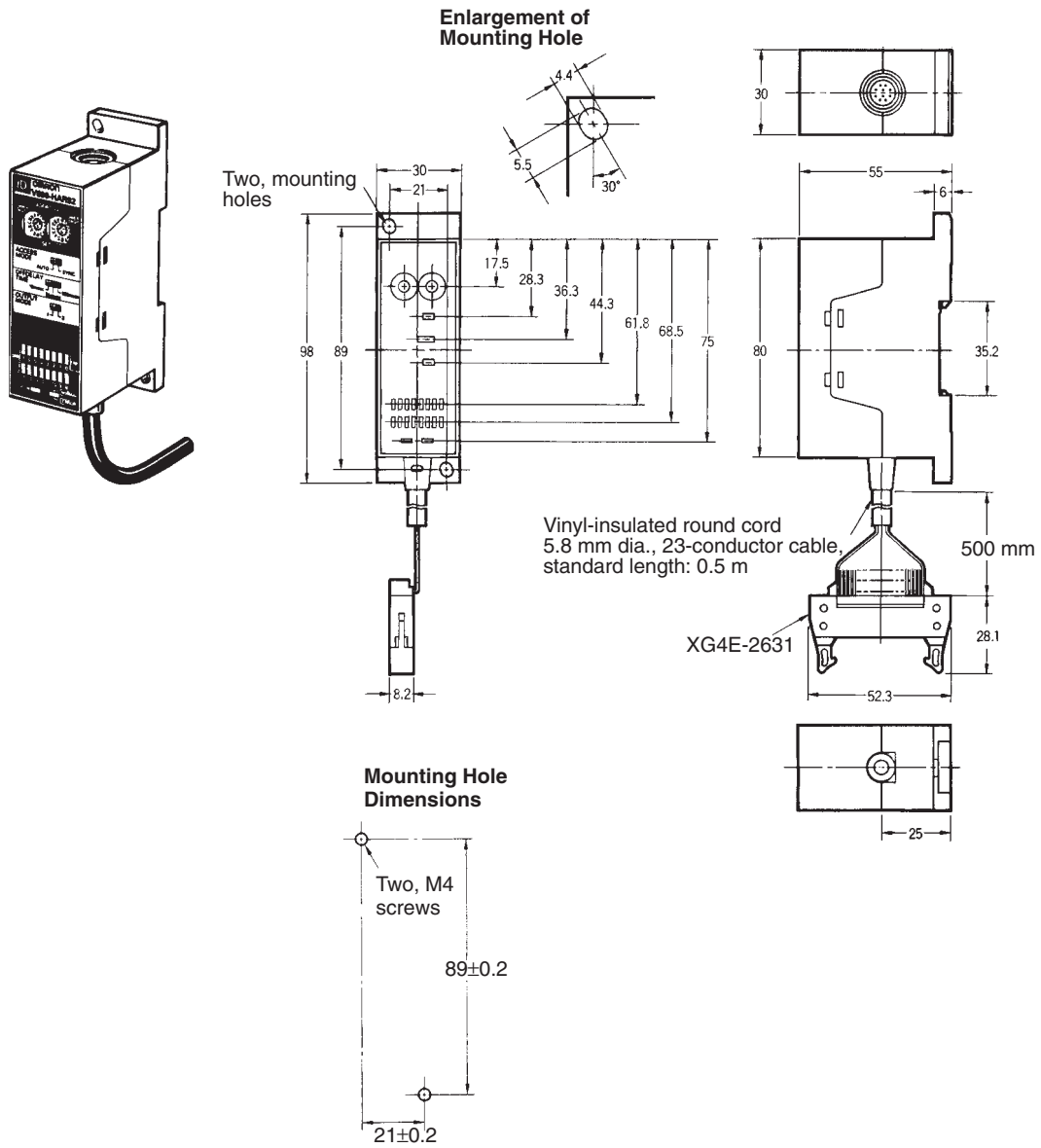

Interface Cables

V600-A6□R Interface Cable for V600-HAR91/-HAR81 Amplifier

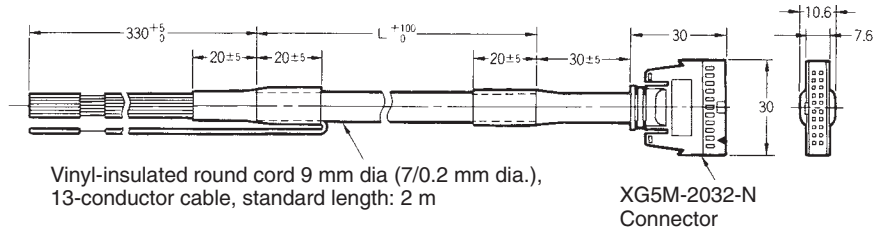
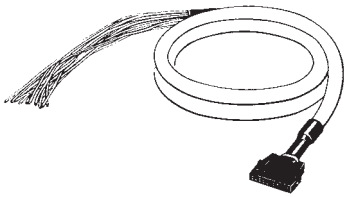

V600-A6□M Interface Cable for V600-HAM91/-HAM81 and V600-HAR92 Amplifier

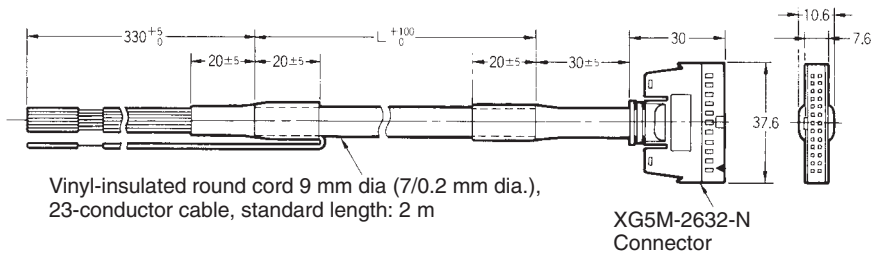
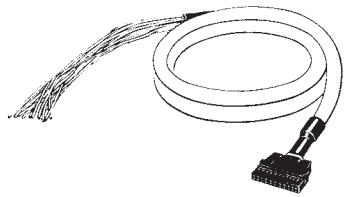

| Interface Cable | L(m) |
|-----------------|------|
| V600-A60R/60M | 2 |
| V600-A61R/61M | 5 |
| V600-A62R/62M | 10 |

2-2 Sensors

There are three Sensor models that can be used for Intelligent Flag and Intelligent Flag II Amplifiers. Select the model best suited for your needs.

2-2-1 Specifications

| Item | V600-HS51 | V600-HS61 | V600-HS63 |
|--|--|-----------|--|
| | | | |
| Transmission frequency | 530 kHz | | |
| Ambient temperature | Operating: -10°C to 60°C Storage: -25°C to 75°C | | Operating: -10°C to 70°C Storage: -25°C to 75°C |
| Ambient humidity | 35% to 95% | | |
| Insulation resistance | 50 MΩ (at 500 VDC) between cable terminal and case | | |
| Dielectric strength | 1,000 VAC, 50/60 Hz for 1 minute between cable terminal and case | | |
| Enclosure ratings | IEC: IP67; JEM: IP67G | | |
| Vibration resistance | Destruction: 10 to 2,000 Hz, 3 mm double amplitude, with 2 sweeps of 15 minutes each in 3 directions | | Destruction: 10 to 500 Hz, 2 mm double amplitude, with 3 sweeps of 11 minutes each in 3 directions |
| Shock resistance | Destruction: 981 m/s ² (approx. 100G), 3 times each in 3 directions (18 times total) | | Destruction: 490 m/s ² (approx. 50G), 3 times each in 3 directions (18 times total) |
| Cable length | 2 m (fixed) | | |
| Wireless transmission error direction | 16-bit CRC (Cyclic Redundancy Check) in both directions | | |
| Indicator | --- | | Power: green |
| Weight | Approx. 70 g | | Approx. 190 g |

2-2-2 Dimensions

V600-HS51 Sensor

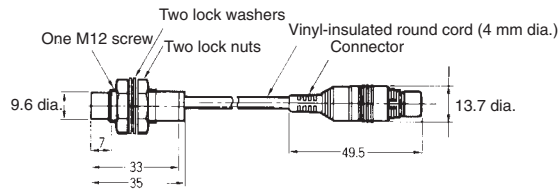

Materials

Case: Brass
 Transmission face: ABS resin
 Filler: Epoxy resin
 Cable: PVC (oil-resistant)

V600-HS61 Sensor

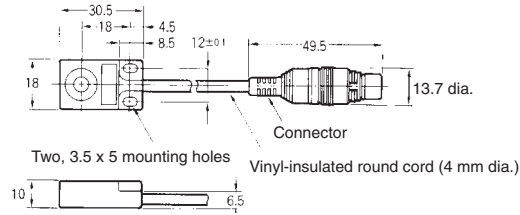
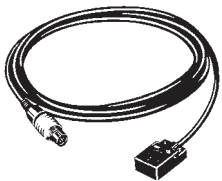

Materials

Case: ABS resin
 Filler: Epoxy resin
 Cable: PVC (oil-resistant)

V600-HS63 Sensor

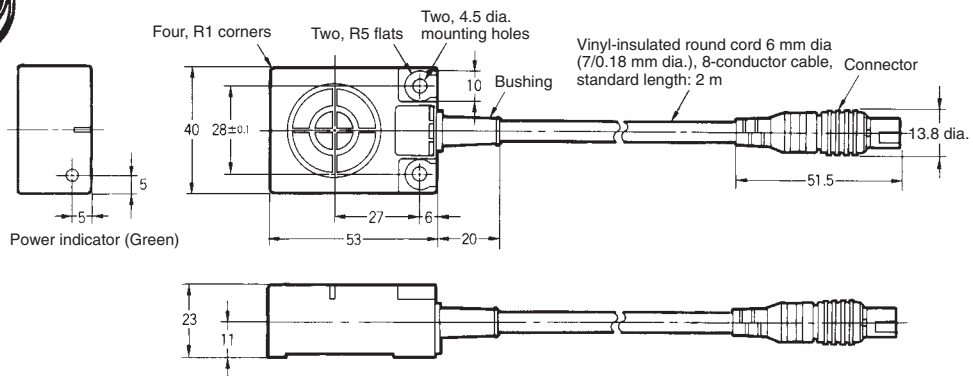
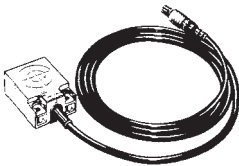

Materials

Case: ABS resin
 Filler: Epoxy resin
 Cable: PVC (oil-resistant)

2-3 EEPROM Data Carriers

2-3-1 Specifications and Dimensions

V600-D23P71 and V600-D23P72 Data Carrier Specifications

| Item | V600-D23P71 | V600-D23P72 |
|---------------------------------------|--|-------------|
| Memory capacity | 254 bytes | |
| Memory type | EEPROM (nonvolatile memory) | |
| Maximum data storage period | 10 years (after data is stored) | |
| Maximum number of data updating times | Data updating between -10°C and 40°C: 300,000 times for each address Data updating between -10°C and 70°C: 100,000 times for each address | |
| Wireless transmission error detection | Two-directional 16-bit Cyclic Redundancy Check (CRC) | |
| Ambient operating temperature | Data storage: -20°C to 110°C, read/write: -10°C to 70°C | |
| Ambient storage temperature | -20°C to 110°C | |
| Ambient operating humidity | 35% to 95% | |
| Enclosure rating | IP66 (IEC Standard) | |
| Vibration resistance | Durability: 10 to 2,000 Hz, 1.5 mm single amplitude, 300 m/s ² (approx. 30G), 30 min each in 3 directions (90 min total) | |
| Shock resistance | Durability: 1,000 m/s ² (approx. 100G), 3 times each in 3 directions (18 times total) | |
| Weight | Approx. 15 g | Approx. 5 g |

Dimensions

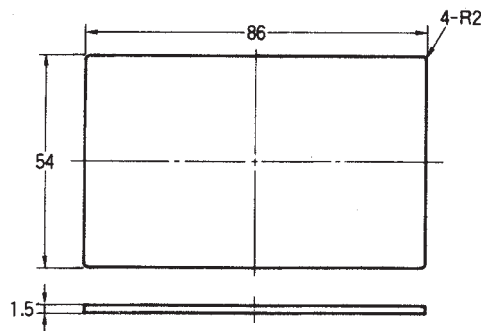

V600-D23P71 Data Carrier

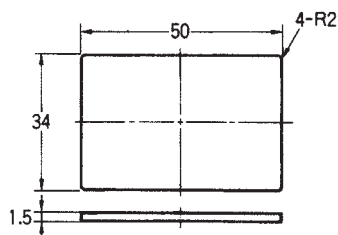

V600-D23PD72 Data Carrier

Material: Glass epoxy resin
Outer surface: Polyurethane resin

V600-A84 Data Carrier Holder

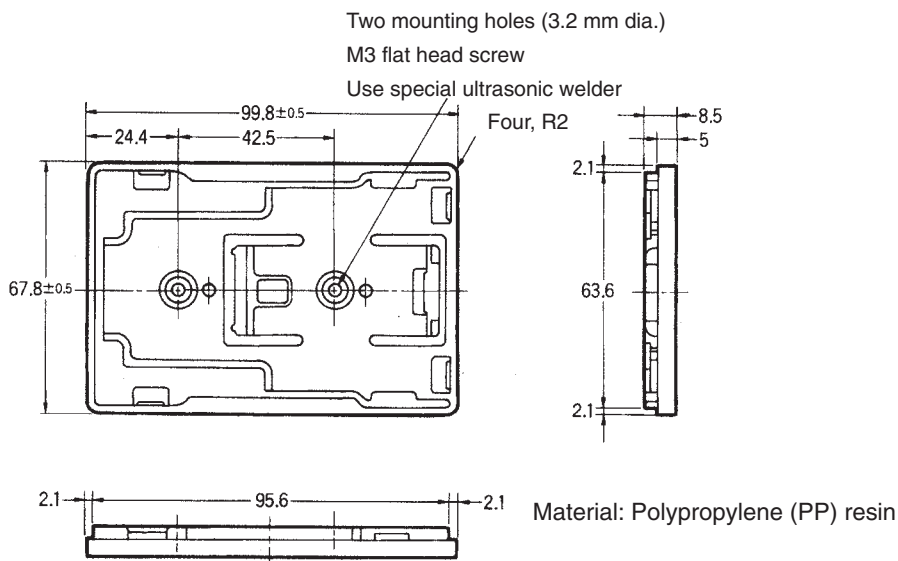

V600-D23P66 Data Carrier Specifications

| Item | V600-D23P66 |
|---------------------------------------|--|
| Memory capacity | 254 bytes |
| Memory type | EEPROM (nonvolatile memory) |
| Maximum data storage period | 10 years (after data is stored) |
| Maximum number of data updating times | Data updating between -20°C and 40°C: 300,000 times for each address Data updating between -20°C and 70°C: 100,000 times for each address |
| Wireless transmission error detection | Bidirectional 16-bit Cyclic Redundancy Check (CRC) |
| Ambient operating temperature | Data storage: -40°C to 110°C, read/write: -20°C to 70°C |
| Ambient storage temperature | -40°C to 110°C |
| Ambient operating humidity | 35% to 95% |
| Enclosure rating | IP68 (IEC Standard), submersible at a maximum water depth of 10 m. |
| Vibration resistance | Durability: 10 to 2,000 Hz, 1.5 mm single amplitude, 300 m/s ² (approx. 30G), 30 min each in 3 directions (90 min total) |
| Shock resistance | Durability: 1,000 m/s ² (approx. 100G), 3 times each in 3 directions (18 times total) |
| Weight | Approx. 6 g |

Dimensions

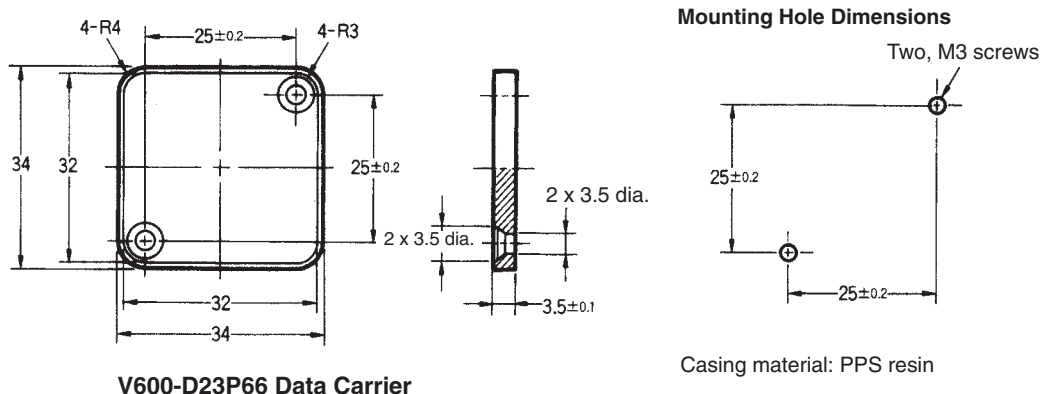

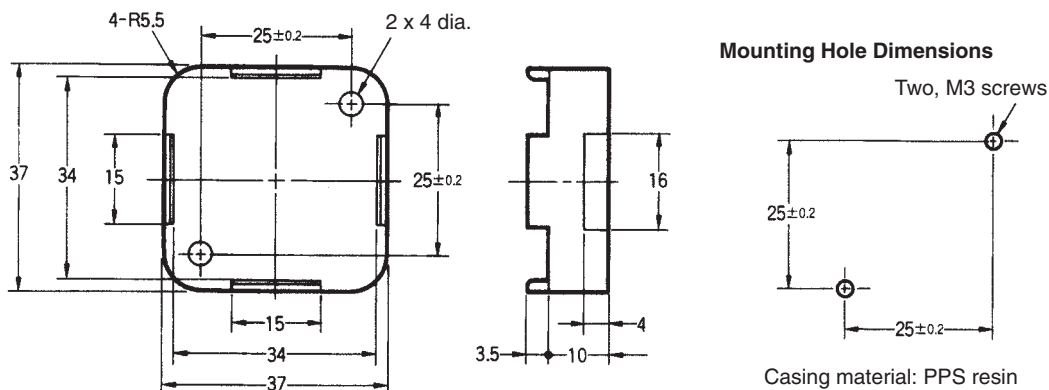

V600-A86 Data Carrier Attachment

V600-D23P66SP Data Carrier Specifications

| Item | V600-D23P66SP |
|---------------------------------------|--|
| Memory capacity | 254 bytes |
| Memory type | EEPROM (nonvolatile memory) |
| Maximum data storage period | 10 years (after data is stored) |
| Maximum number of data updating times | Data updating between -20°C and 40°C: 300,000 times for each address Data updating between -20°C and 70°C: 100,000 times for each address |
| Wireless transmission error detection | Bidirectional 16-bit Cyclic Redundancy Check (CRC) |
| Ambient operating temperature | Data storage: -40°C to 110°C, read/write: -20°C to 70°C |
| Ambient storage temperature | -40°C to 110°C |
| Ambient operating humidity | 35% to 95% |
| Enclosure rating | IP67 (IEC Standard)/IP67G (JEM Standard) |
| Vibration resistance | Durability: 10 to 2,000 Hz, 1.5 mm single amplitude, 300 m/s ² (approx. 30G), 30 min each in 3 directions (90 min total) |
| Shock resistance | Durability: 1,000 m/s ² (approx. 100G), 3 times each in 3 directions (18 times total) |
| Weight | Approx. 19 g |

Dimensions

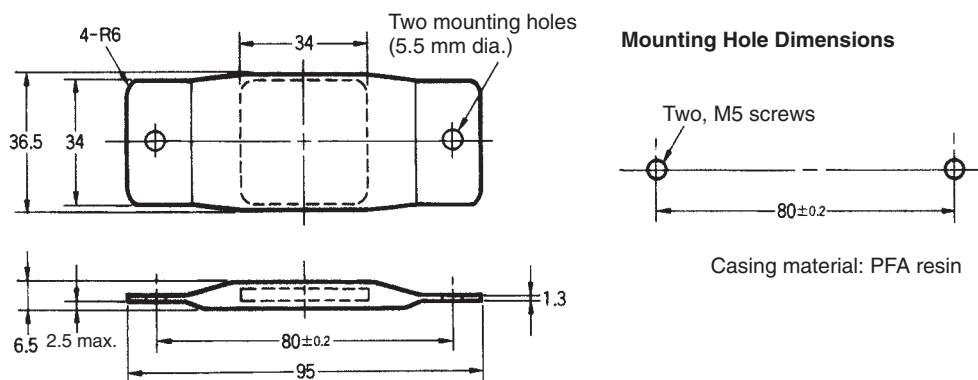

V600-D23P66SP Data Carrier

V600-D23P61, V600-D23P53, and V600-D23P54 Data Carrier Specifications

| Item | V600-D23P61 | V600-D23P53 | V600-D23P54 |
|---------------------------------------|--|---------------|---------------|
| Memory capacity | 254 bytes | | |
| Memory type | EEPROM (nonvolatile memory) | | |
| Maximum data storage period | 10 years (after data is stored) | | |
| Maximum number of data updating times | Data updating between -25°C and 40°C: 300,000 times for each address Data updating between -25°C and 70°C: 100,000 times for each address | | |
| Wireless transmission error detection | Bidirectional 16-bit Cyclic Redundancy Check (CRC) | | |
| Ambient operating temperature | Data storage: -40°C to 85°C, read/write: -25°C to 70°C | | |
| Ambient storage temperature | -40°C to 85°C | | |
| Ambient operating humidity | 35% to 95% | | |
| Enclosure rating | IP67 (IEC Standard)/IP67G (JEM Standard) | | |
| Vibration resistance | Durability: 10 to 2,000 Hz, 1.5 mm single amplitude, 300 m/s ² (approx. 30G), 30 min each in 3 directions (90 min total) | | |
| Shock resistance | Durability: 1,000 m/s ² (approx. 100G), 3 times each in 3 directions (18 times total) | | |
| Weight | Approx. 5.8 g | Approx. 0.4 g | Approx. 1.0 g |

Dimensions

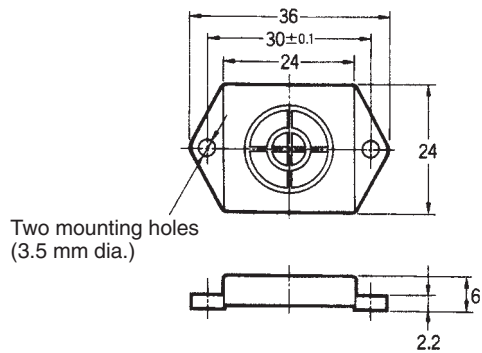

V600-D23P61 Data Carrier

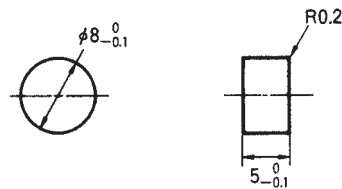

V600-D23P53 Data Carrier

Casing material: ABS resin
 Filler resin: Epoxy resin

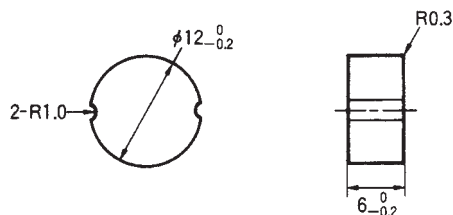

V600-D23P54 Data Carrier

2-3-2 Memory Map

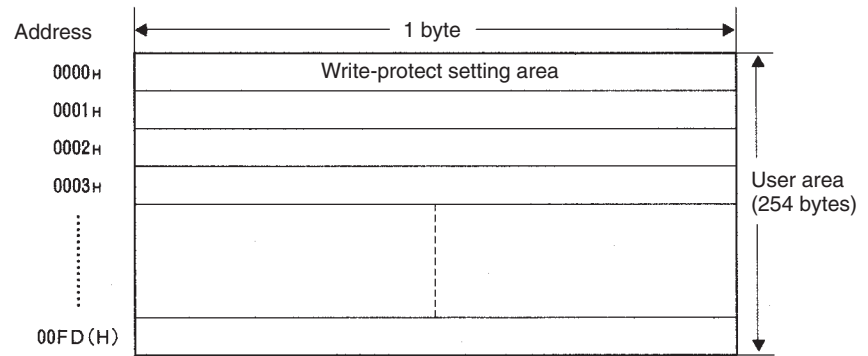

- EEPROM is used as a memory for Data Carrier.
- The user area including the write-protect setting area (address 0000_H) is 254 bytes.

2-3-3 Write-protection

The write-protection prevents important data stored in the Data Carrier such as the model and type from being overwritten by other data. Write-protection can be set in the following way.

Write-protect Setting Procedure

If a write-protected end address is specified in address 0000_H in the Data Carrier, the area between address 0001_H and the write-protected end address is write-protected. Whether or not write-protection is effected is specified by the most significant bit of address 0000_H.

| | | | | | | | | |
|-------------------|------------|-------------|---|---|---|---|---|---|
| Address | 7 | 6 | 5 | 4 | 3 | 2 | 1 | 0 |
| 0000 _H | YES/ NO | End address | | | | | | |

Write-protect execution bit (Most significant bit of address 0000_H)

- 1: Write-protected
- 0: Not write-protected

End address setting range: 00_H or 01_H to 7F_H

Addresses 0080_H to 00FD_H cannot be specified as the end address. If 00_H is specified as the end address, addresses 0001_H to 00FD_H will be write-protected.

Write-protect Setting Examples

The area between addresses 0001_H and 0012_H is write-protected by the following setting.

| | | | | | | | | |
|-------------------|---|---|---|---|---|---|---|---|
| Address | 7 | 6 | 5 | 4 | 3 | 2 | 1 | 0 |
| 0000 _H | 1 | 0 | 0 | 1 | 0 | 0 | 1 | 0 |
| | 9 | | | | 2 | | | |

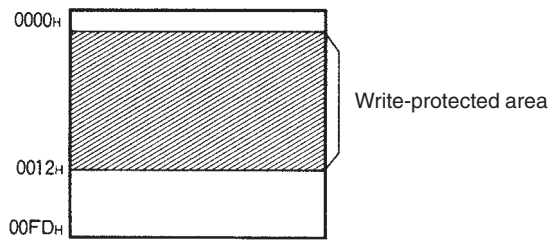

If the end address is 00_H, the entire area except address 0000_H will be write-protected.

| | | | | | | | | |
|-------------------|---|---|---|---|---|---|---|---|
| Address | 7 | 6 | 5 | 4 | 3 | 2 | 1 | 0 |
| 0000 _H | 1 | 0 | 0 | 0 | 0 | 0 | 0 | 0 |
| | 8 | | | | 0 | | | |

When the end address is 00_H, the write-protected area is as follows:

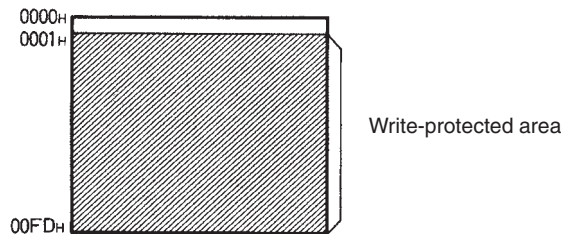

Cancelling Write Protection

To cancel write-protection, set the most significant bit of address 0000_H to 0. The write-protected area specified in address 0000_H will become invalid. Accordingly, the write-protected area will be cancelled.

Key Points

- 1, 2, 3... 1. Address 0000_H cannot be write-protected.
2. The write-protect start address is fixed at 0001_H. Always specify the write-protected area starting from address 0001_H.

2-4 SRAM Data Carriers

2-4-1 Specifications and Dimensions

V600-D8KR12, V600-D8KR13, and V600-D8KR04 Data Carrier Specifications

| Item | V600-D8KR12 | V600-D8KR13 | V600-D8KR04 |
|---------------------------------------|---|--------------|---------------|
| Memory capacity | 8 KB | | |
| Memory type | SRAM (volatile memory) | | |
| Battery life | See the battery life graphs shown in 2-4-4 Battery Life. | | |
| Data read/write count | Unlimited (for the life of the battery) | | |
| Wireless transmission error detection | Two directional 16-bit Cyclic Redundancy Check (CRC) | | |
| Ambient operating temperature | Data storage: -40°C to 70°C, read/write: -25°C to 70°C | | |
| Ambient storage temperature | -40°C to 70°C | | |
| Ambient operating humidity | 35% to 95% | | |
| Enclosure rating | IP67 (IEC Standard), IP67G (JEM Standard) | | |
| Vibration resistance | Durability: 10 to 500 Hz, 1.0 mm single amplitude, 150 m/s ² (approx. 15G), with three sweeps of 11 min each in 3 directions | | |
| Shock resistance | Durability: 1,000 m/s ² (approx. 100G), 3 times each in 3 directions (18 times total) | | |
| Weight | Approx. 70 g | Approx. 70 g | Approx. 160 g |

Dimensions

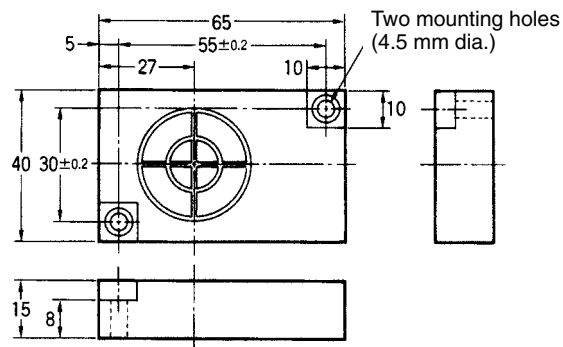

V600-D8KR12 Data Carrier

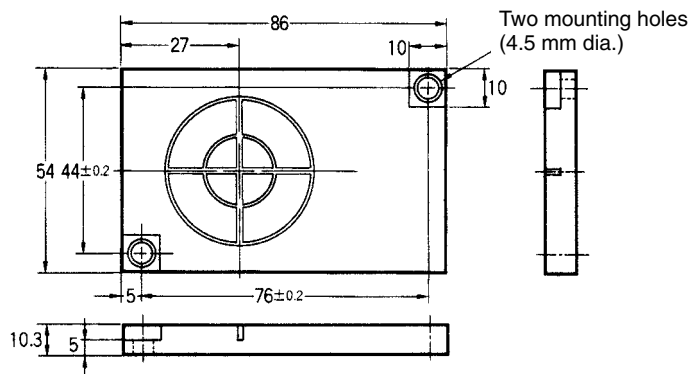

V600-D8KR13 Data Carrier

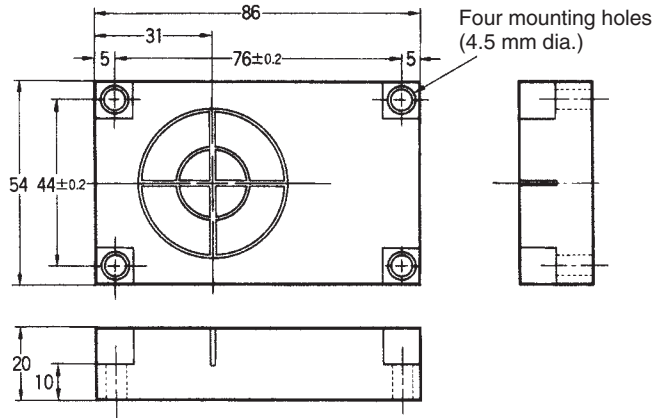

Materials

Casing material: ABS resin
 Filler resin: Epoxy resin

V600-D8KR04 Data Carrier

⚠ WARNING Do not attempt to take a SRAM Data Carrier apart or expose the SRAM Data Carrier to pressures that would distort it, temperatures above 100°C, or fire. The Data Carrier has a built-in lithium battery which may catch fire or explode if not handled properly.

V600-D2KR16 Data Carrier Specifications

| Item | V600-D2KR16 |
|---------------------------------------|---|
| Memory capacity | 2 KB |
| Memory type | SRAM (volatile memory) |
| Battery life (see note 1) | 2 years (battery replaceable) |
| Data read/write count | Unlimited (regardless of battery life) |
| Wireless transmission error detection | Two directional 16-bit Cyclic Redundancy Check (CRC) |
| Ambient operating temperature | Data storage: -15°C to 70°C, read/write: 0°C to 50°C |
| Ambient storage temperature | -15°C to 70°C |
| Ambient operating humidity | 35% to 85% |
| Enclosure rating (see note 2) | IP50 (IEC Standard) |
| Vibration resistance | Durability: 10 to 150 Hz, 1.5 mm multi-amplitude, 100 m/s ² (approx. 10G), for 30 min X,Y,Z directions |
| Shock resistance | Durability: 300 m/s ² (approx. 30G), 3 times each in 3 directions (18 times total) |
| Weight | Approx. 15 g |

- Note**
1. This battery life is applicable when a battery is used at 25°C. See 2-4-4 *Battery Life* for the relationship between battery life and temperature. Replacement batteries (CR2016) are available. For details, see the appendix.
 2. The enclosure rating complies with IP50 when the attached battery replacement cover seal is affixed to the back of the Data Carrier.

Dimensions

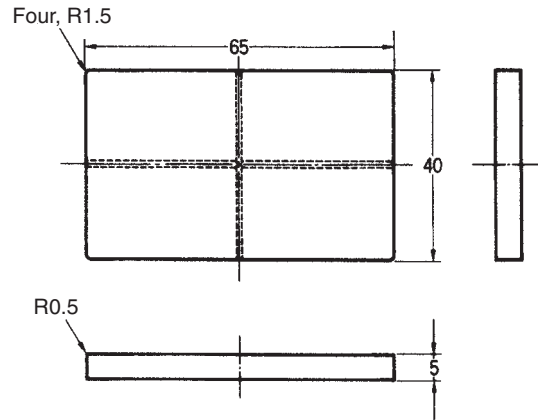

V600-D2KR16 Data Carrier

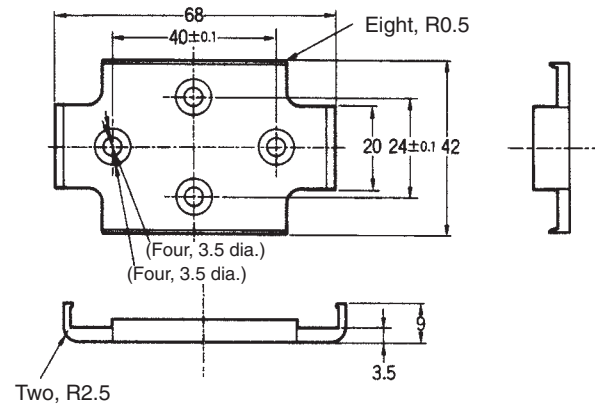

Casing material: ABS resin

V600-A81 Data Carrier Holder

⚠ WARNING Do not attempt to take a SRAM Data Carrier apart or expose the SRAM Data Carrier to pressures that would distort it, temperatures above 100°C, or fire. The Data Carrier has a built-in lithium battery which may catch fire or explode if not handled properly.

2-4-2 Memory Map

The Data Carrier has a memory area of maximum 8 Kbytes. One byte of data can be stored at each address.

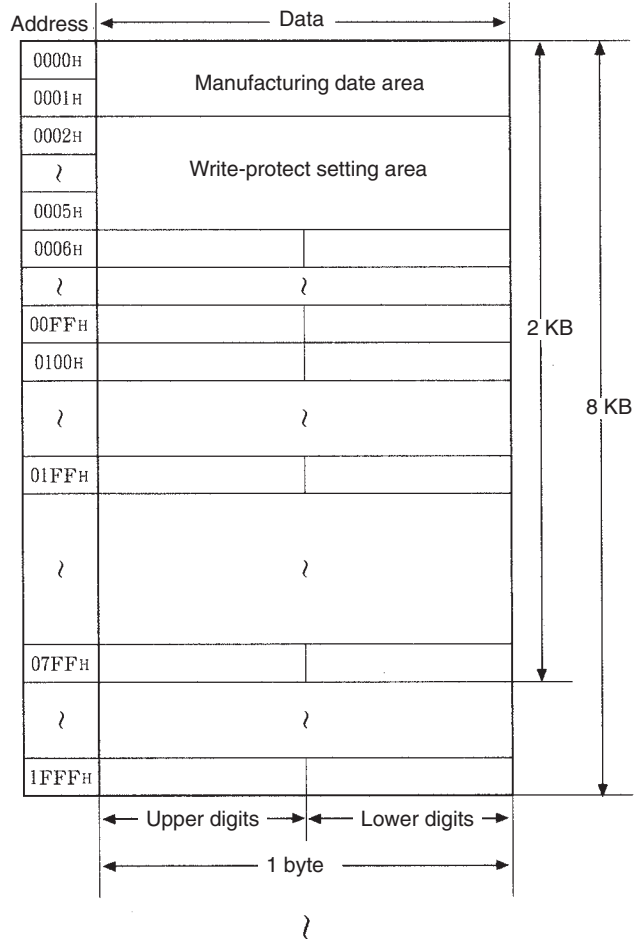

- The Data Carrier uses SRAM as a memory. There is not limit to the read/write counts.
- The maximum memory capacity is 8 Kbytes.
 Address space for 8-Kbyte Data Carrier 0000_H to 1FFF_H
 Address space for 2-Kbyte Data Carrier 0000_H to 07FF_H
- Memory data is retained by a built-in lithium battery.

Default Contents of Manufacturing Date Area

| Address | 7 | 6 | 5 | 4 | 3 | 2 | 1 | 0 |
|-------------------|-----------------------|---|---|---|----------------------|---|---|---|
| 0000 _H | Second digit of month | | | | First digit of month | | | |
| 0001 _H | Second digit of year | | | | First digit of year | | | |

- Note**
1. The year of manufacturing is represented by the last two digits of the year (for example, “96” for 1996).
 2. The month of manufacturing is represented by two digits (for example, “03” for March and “10” for October).
 3. For the V600-D2KR16, no data is entered in the manufacturing date area before shipping.
 4. This area is for read-only.

2-4-3 Write-protection

The write-protection prevents important data stored in the Data Carrier, such as the model and type, from being overwritten by other data. Write-protection can be set in the following way.

Write-protect Setting Procedure

Addresses 0002_H to 0005_H (four bytes) in the Data Carrier are used to set the write-protected area. Whether or not write protection is effected is specified by the most significant bit of address 0002_H.

Enabling Write Protection

| Address | 7 | 6 | 5 | 4 | 3 | 2 | 1 | 0 |
|-------------------|-----------------------------------|-----------------------------------|---|---|---|---|---|---|
| 0002 _H | YES/ NO | Upper two digits of start address | | | | | | |
| 0003 _H | Lower two digits of start address | | | | | | | |
| 0004 _H | Upper two digits of end address | | | | | | | |
| 0005 _H | Lower two digits of end address | | | | | | | |

- Write-protect setting bit (most significant bit of address 0002_H)
 - 1: Write protected
 - 0: Not write protected
- Write-protect setting area
 - Start address: 0006_H to 1FFF_H
 - End address: 0006_H to 1FFF_H

Write-protect Setting Examples

1, 2, 3... 1. Protecting Addresses 0015_H to 0120_H

Start address < End address

| Address | 7 | 6 | 5 | 4 | 3 | 2 | 1 | 0 |
|-------------------|---|---|---|---|---|---|---|---|
| 0002 _H | 1 | 0 | 0 | 0 | 0 | 0 | 0 | 0 |
| | 8 | | | | 0 | | | |
| 0003 _H | 0 | 0 | 0 | 1 | 0 | 1 | 0 | 1 |
| | 1 | | | | 5 | | | |
| 0004 _H | 0 | 0 | 0 | 0 | 0 | 0 | 0 | 1 |
| | 0 | | | | 1 | | | |
| 0005 _H | 0 | 0 | 1 | 0 | 0 | 0 | 0 | 0 |
| | 2 | | | | 0 | | | |

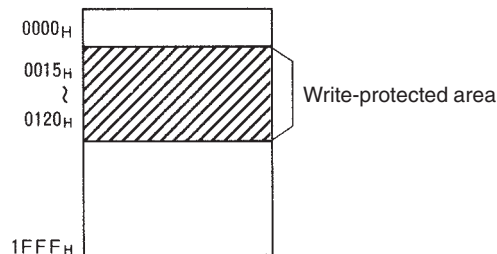

2. Protecting Only One Byte

Start address = End address

The same address is specified for the start and end addresses.

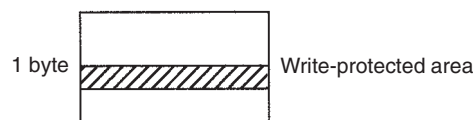

3. End Address Higher than Final Address

End address > 1FFF_H

Since the memory area in the Data Carrier is from 0000_H to 1FFF_H, the area between the start address and 1FFF_H is write-protected.



4. Start Address Higher than End Address

Start address > End address

The area between 0006_H and the end address and the area between the start address and 1FFF_H are write-protected.

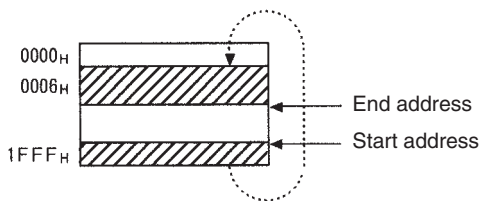

Cancelling Write-protection

To cancel write protection, set the most significant bit of address 0002_H to 0. The write-protection specified in addresses 0002_H to 0005_H will become invalid. Accordingly, the write protection will be cancelled.

2-4-4 Battery Life

The Data Carrier has a built-in lithium battery. The graphs below show the relationship between the battery life of each Data Carrier, the number of bytes transmitted, and the number of transmission times per day. Use this information for reference when combining Data Carriers with existing systems.

V600-D8KR12D Data Carriers (Typical)

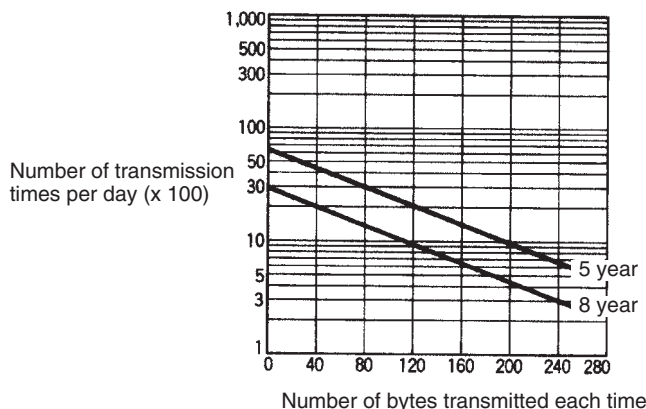

V600-D8KR13 Data Carriers (Typical)

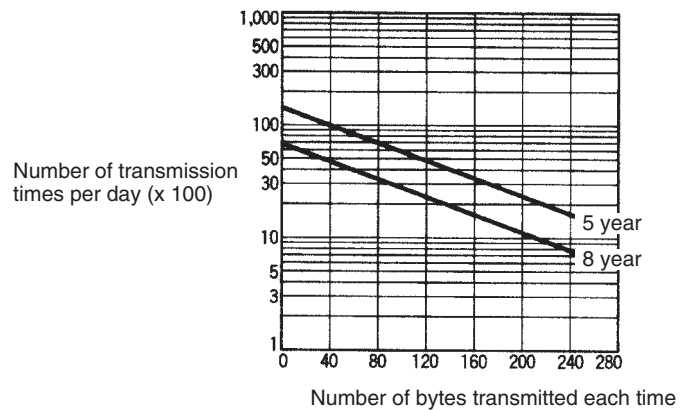

V600-D8KR04 Data Carriers (Typical)

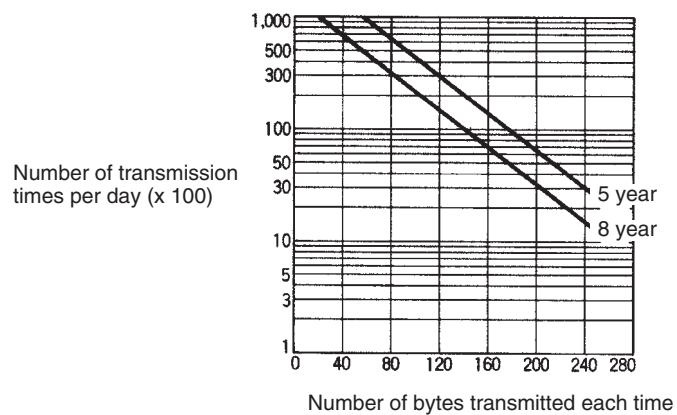

Instructions Before Use

- The above data is the lowest possible performance data under an ambient temperature range of -10°C and 55°C . Normally, the higher the ambient temperature, the shorter the battery life.

V600-D8KR12D Data Carriers

If 40-byte data is transmitted 2,000 times a day at an ambient metal temperature of 55°C , the battery life will be 8 years. If 40-byte data is transmitted 4,500 times a day at an ambient metal temperature of 55°C , the battery life will be 5 years.

V600-D8KR04 Data Carriers

If 200-byte data is transmitted 3,000 times a day at an ambient metal temperature of 55°C , the battery life will be 8 years. If 200-byte data is transmitted 6,500 times a day at an ambient metal temperature of 55°C , the battery life will be 5 years.

- If the Data Carrier remains stopped within the transmission area in AUTO mode for an Intelligent Flag Amplifier or in both AUTO and trigger modes for the Intelligent Flag II Amplifier, the battery life may be extremely shortened. In this situation, turn off the Amplifier, or turn ON the INHIBIT input signal to stop the Sensor from oscillating. In particular, if the Data Carrier remains stopped within the transmission area, the Intelligent Flag II Amplifier will repeat access operations to try to locate a Data Carrier. To prevent this, move the Data Carrier out of the transmission area after transmission is complete. Alternatively, take battery power consumption into account when designing the system.

• **Power Consumption of Built-in Data Carrier Battery**

The following table shows the approximate power consumption of the built-in battery when the Data Carrier remains stopped within the transmission area for one day (24 hours).

| Model | Built-in battery capacity | Power consumption per day | Power consumption vs battery capacity |
|---------------|---------------------------|---------------------------|---------------------------------------|
| V600-D8KR12D | 410 mA/h | 1.68 mA/h (0.07 mA/h) | 0.41% |
| V600-D8KR13 | 1,000 mA/h | | 0.168% |
| V600-D8KR04 | 19,000 mA/h | | 0.088% |
| (V600-D8KR11) | 1,900 mA/h | | 0.088% |

V600-D2KR16 Data Carriers The battery life is two years (at 25°C) regardless of the number of transmission times and the number of data bytes read and written.

Relationship between Battery Life and Temperature (Typical)

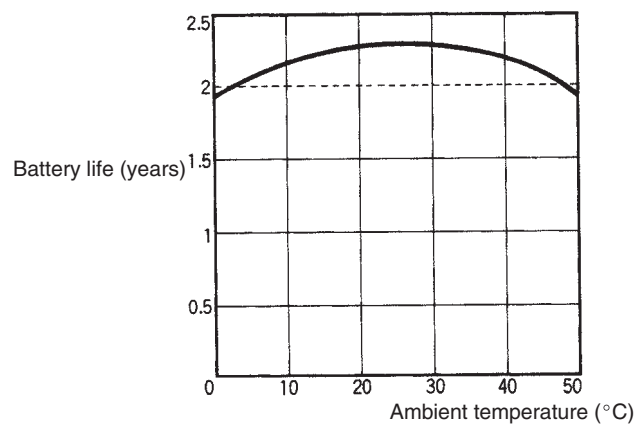

The above graph indicates the service life of a battery that is loaded in a Data Carrier with the insulating sheet removed. The following table shows the service life of a battery that is not loaded in a Data Carrier.

Rough Guideline

| Temperature | Battery power consumption per year (%) |
|-------------|--|
| 20 | 1 |
| 30 | 2 |
| 40 | 4 |
| 50 | 8 |
| 60 | 16 |
| 70 | 32 |

Example:

If the battery is stored at 70°C without being loaded in a Data Carrier, it will last for 1.36 years [2 years x (1 – 0.32) = 1.36 years]. If the battery is used at 25°C after being stored at 70°C for one year, it will last for approximately one year and four months. If the battery is used around 0°C or 50°C, its service life will become even shorter.

Instructions Before Use

- 1, 2, 3... 1. Data is erased when the battery is changed. Be sure to backup data before changing the battery.
2. The enclosure rating complies with IP50 when the attached battery replacement cover seal is affixed to the back of the Data Carrier. Refer to 4-3-24 for details.

SECTION 3

Wireless Transmission Specifications

This section provides the transmission specifications, including transmission distances and transmission times.

| | | |
|-------|--|----|
| 3-1 | Transmission Distance | 54 |
| 3-1-1 | Transmission Distance Specifications | 54 |
| 3-1-2 | Transmission Range Graphs (Actual Values) | 55 |
| 3-2 | Transmission Time | 56 |
| 3-2-1 | Transmission Time Specifications | 56 |
| 3-2-2 | Data Carrier Travel Speed (Conveyor Speed) | 57 |

3-1 Transmission Distance

The transmission distance between the Sensor and the Data Carrier differs depending on installation conditions and the combination of Sensor and Data Carrier. This section describes the recommended combinations of Sensors and Data Carriers, and transmission distance specifications.

3-1-1 Transmission Distance Specifications

| Data Carrier | | V600-HAR91/-HAR81/-HAM91/-HAM81/-HAR92 Amplifier | | |
|---------------|---------------|--|------------------|------------------|
| | | V600-HS51 Sensor | V600-HS61 Sensor | V600-HS63 Sensor |
| Memory EEPROM | V600-D23P53 | 0.5 to 3.0 mm | 0.5 to 3.0 mm | — |
| | V600-D23P54 | 0.5 to 5.0 mm | 0.5 to 5.5 mm | — |
| | V600-D23P61 | 0.5 to 8.0 mm | 0.5 to 9.0 mm | 2 to 16 mm |
| | V600-D23P66 | — | — | 5 to 30 mm |
| | V600-D23P66SP | — | — | 5 to 25 mm |
| | V600-D23P71 | — | — | 5 to 35 mm |
| | V600-D23P72 | — | 0.5 to 18 mm | 5 to 35 mm |
| Memory SRAM | V600-D8KR12D | 5 to 15 mm | 5 to 18 mm | 5 to 45 mm |
| | V600-D8KR13 | — | — | 10 to 30 mm |
| | V600-D2KR16 | — | — | 2 to 15 mm |
| | V600-D8KR04 | — | — | 10 to 65 mm |

- Note**
1. The above specifications are guaranteed performance values that can be obtained under any ambient temperatures or variations in product performance.
 2. The transmission distance is the same for read and write operations.
 3. **Sensor Installation Conditions**
 V600-HS51: Flush-mounted in metal (ferrous)
 Axial offset from Data Carrier: ± 2.0 mm
 V600-HS61: Surface-mounted on metal (ferrous)
 Axial offset from Data Carrier: ± 2.0 mm
 V600-HS63: Surface-mounted on metal (ferrous)
 Axial offset from Data Carrier: ± 10.0 mm
 4. **Data Carrier Installation Conditions**
 V600-D23P53/-P54: Flush-mounted in iron
 V600-D23P66/-P66SP/-P71/-P72: Surface-mounted on resin
 (no metal on the back)
 V600-D23P61: Surface-mounted on metal (ferrous)
 V600-D8KR12D/-13/-04: Surface-mounted on metal (ferrous)
 V600-D2KR16: Attached to holder mounted on metal
 (ferrous or aluminum)
 5. These transmission distance specifications are also applicable when the Sensor and Data Carrier are mounted on non-metallic surfaces.
 6. These transmission distance specifications apply when the Data Carrier is stationary.

3-1-2 Transmission Range Graphs (Actual Values)

This section illustrates the transmission ranges for the Sensor to communicate with the Data Carrier (unit of length: mm).

V600-HS51 Sensor

V600-HS51 + V600-D23P53

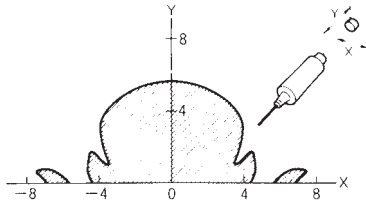

V600-HS51 + V600-D23P54

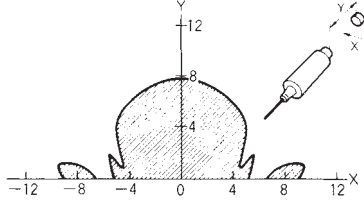

V600-HS51 + V600-D23P61

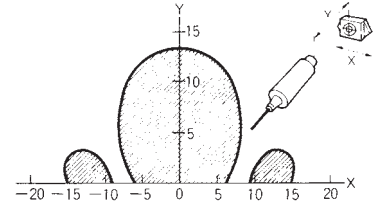

V600-HS51 + V600-D8KR12D

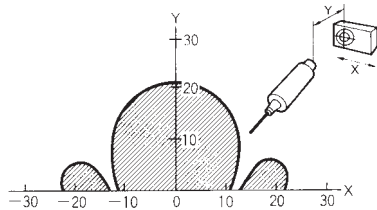

V600-HS61 Sensor

V600-HS61 + V600-D23P53

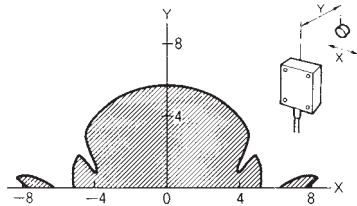

V600-HS61 + V600-D23P54

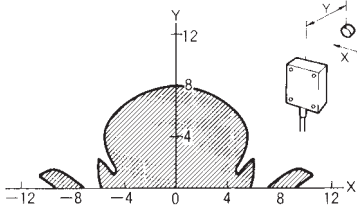

V600-HS61 + V600-D23P61

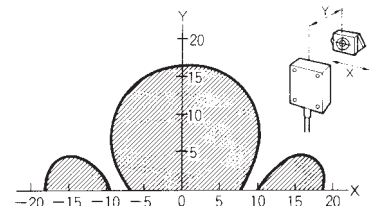

V600-HS61 + V600-D23P72

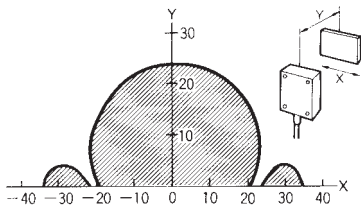

V600-HS61 + V600-D8KR12D

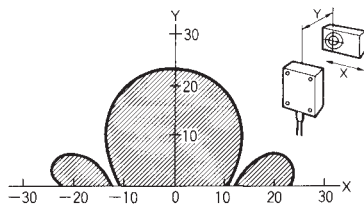

V600-HS63 Sensor

V600-HS63 + V600-D23P61

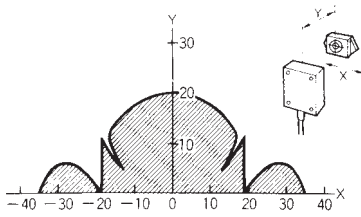

V600-HS63 + V600-D23P66

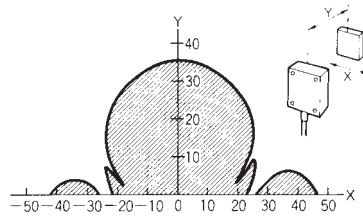

V600-HS63 + V600-D23P66SP

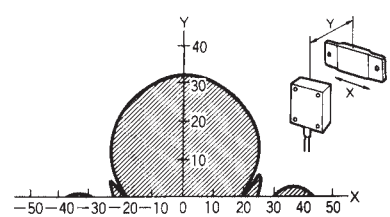

V600-HS63 + V600-D23P71

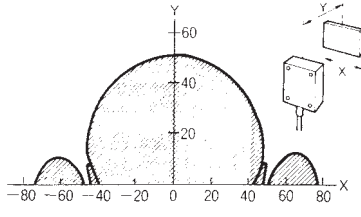

V600-HS63 + V600-D23P72

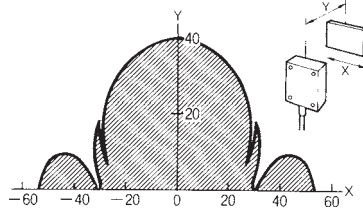

V600-HS63 + V600-D8KR12D

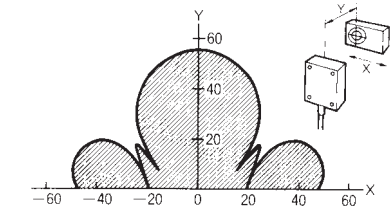

V600-HS63 + V600-D8KR13

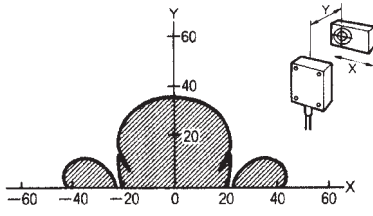

V600-HS63 + V600-D2KR16

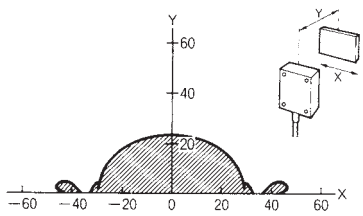

V600-HS63 + V600-D8KR04

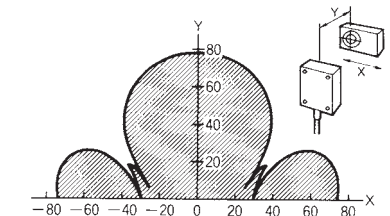

3-2 Transmission Time

The transmission time is the time required for the Sensor to communicate with the Data Carrier. For the Intelligent Flag Amplifiers, write processing requires a longer transmission time than read processing.

3-2-1 Transmission Time Specifications

| Data Carrier | V600-HAR91/-HAR81/-HAM91/-HAM81 Amplifier | | | V600-HAR92 Amplifier |
|--------------|---|-----------|------------------------------|----------------------|
| | Read | Write | | Read |
| | DATA READ mode, VERIFY mode | BYTE mode | BIT SET mode, BIT CLEAR mode | DATA READ mode |
| EEPROM | 75 ms | 138 ms | 150 ms | 77 ms |
| SRAM | 60 ms | 95 ms | 107 ms | 62 ms |

3-2-2 Data Carrier Travel Speed (Conveyor Speed)

The transmission range and transmission time for the Intelligent Flag or Intelligent Flag II Amplifier and Sensors determine the Data Carrier travel speed (conveyor speed) on the production line.

$$\text{Data carrier travel speed (conveyor speed)} = \frac{\text{Data carrier travel distance within transmission range (x)}}{\text{Transmission time}}$$

Example: V600-HAR91/-HAR81 Amplifier, V600-HS63 Sensor, and V600-D8KR04 Data Carrier

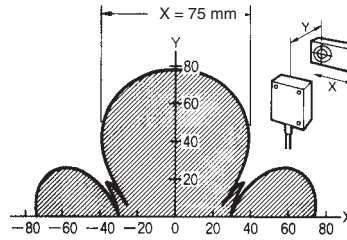

$$\text{Data Carrier travel speed (meters per minute)} = \frac{75 \text{ mm}}{60 \text{ ms}} = \frac{75 \times 10^{-3} \text{ m}}{60 \times 10^{-3} \times 1/60 \text{ min}} = 75 \text{ m/min}$$

- Note**
1. Since the Data Carrier travel speed varies with the transmission distance (Y) and axial offset, we recommend that the widest distance within the transmission range be used by referring to the transmission range graphs.
 2. The calculated value is for reference purposes only. The actual travel speed should be determined by conducting system tests.
 3. The above formula does not account for transmission error processing.

SECTION 4

Installation

This section provides installation instructions for Amplifiers, Sensors, and Data Carriers.

| | | |
|-------|---|----|
| 4-1 | Installing Amplifiers | 60 |
| 4-1-1 | Installation Environment | 60 |
| 4-1-2 | Installation Methods | 60 |
| 4-1-3 | Connecting Interface Cables | 63 |
| 4-1-4 | Connecting Sensors | 64 |
| 4-2 | Installing Sensors | 64 |
| 4-2-1 | Installation Methods | 64 |
| 4-2-2 | Effects of Surrounding Metal on Sensors | 66 |
| 4-2-3 | Mutual Interference Between Sensors | 68 |
| 4-2-4 | Mutual Interference Between Proximity Sensors and Sensors | 70 |
| 4-3 | Installing Data Carriers | 71 |
| 4-3-1 | Installing EEPROM Data Carriers | 71 |
| 4-3-2 | Installing SRAM Data Carriers | 80 |

4-1 Installing Amplifiers

4-1-1 Installation Environment

Installation Site

Avoid installing the Intelligent Flag and Intelligent Flag II Amplifier in the following places:

- Places where the ambient temperature drops below -10°C or exceeds 55°C or where sudden temperature changes cause condensation.
- Places where the relative humidity drops below 35% or exceeds 85%.
- Places exposed to corrosive gases, inflammable gases, dust, salinity, or iron dust.
- Places where vibration or shock is directly transmitted to the Amplifier.
- Places exposed to direct sunlight.
- Places exposed to spattering water, oil, chemicals, and other liquids.

Installation Position Inside Control Panels

The ambient temperature for the Amplifier must be between -10°C and 55°C . Note the following items:

- Provide enough space for ventilation. In particular, when multiple Amplifiers are to be installed side by side, install a fan to allow each Amplifier to dissipate heat properly.
- Avoid installing the Amplifier near heat-generating devices, such as heaters, transformers, or high-capacity resistors.
- If power cables such as motor power cables (through which high current flows) are to be routed near the Amplifier, conduct enough tests and carefully route these cables taking the wiring conditions into account.

4-1-2 Installation Methods

The Amplifier can be either mounted directly with screws or mounted onto DIN Track.

Installing Amplifiers Directly

To install the Amplifier directly, always use flat washers and two M4 screws to secure it.

Mounting Hole Dimensions

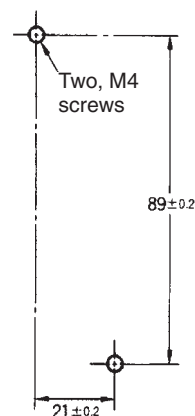

Installing Amplifiers onto a DIN Track

- 1, 2, 3...**
1. To install the Amplifier onto a DIN Track, hitch the Amplifier at portion A and press it in the direction indicated by arrow B.
 2. To remove the Amplifier from the DIN Track, pull the mounting hook towards you.

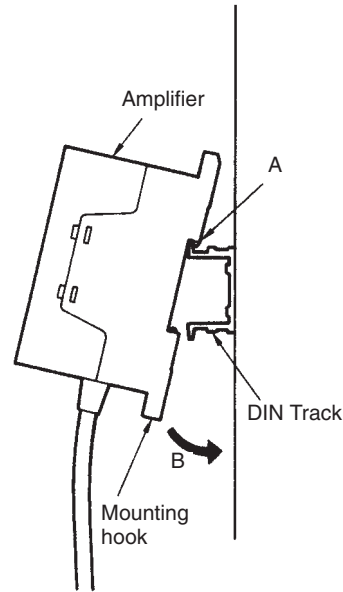

DIN Track
PFP-100N2 (Supplied by OMRON)



End Plate
PFP-M (Supplied by OMRON)

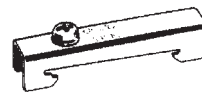

Clearance Between Amplifiers

When installing multiple V600-HAR91, V600-HAR81, or V600-HAR92 Amplifiers side by side, provide at least 10 mm clearance between Amplifiers to allow them to dissipate heat properly.

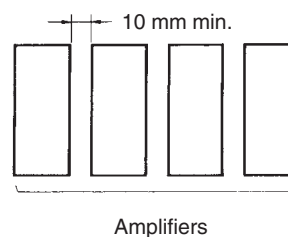

Use at least two spacers (supplied by OMRON) on a DIN Track. The width of each spacer is 5 mm.

**Spacer
PFP-S**



Grounding

The FG line is provided for grounding. When the V600-HA□91/92 Amplifiers is to be used in a place subject to excessive noise or it malfunctions, ground the Amplifier to a resistance of 100 Ω max.

Sharing the ground wire with other equipment or grounding to the beam of a building will adversely affect operation.

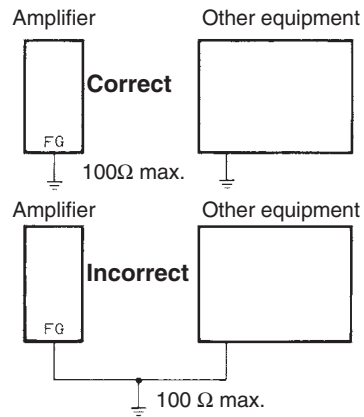

**Exposure to Spattering
Water or Oil**

The Amplifier and its connector to the Interface Cable are not waterproof. Be sure to house them in a control box.

4-1-3 Connecting Interface Cables

Connection Method

The Amplifier and Interface Cable are connected with connectors. Inserting the connector of the Interface Cable into the connector of the Amplifier locks them with the right and left locks.

Extending Interface Cables

The Interface Cable comes in three models: 2 m, 5 m, and 10 m. The maximum cable length is 10 m. Extending the cable length to more than 10 m may cause malfunctions or reduce noise resistance.

Exposure to Water or Oil Splashes

The connectors are not waterproof. If the connectors may be exposed to splattering water or oil, keep them inside a control box.

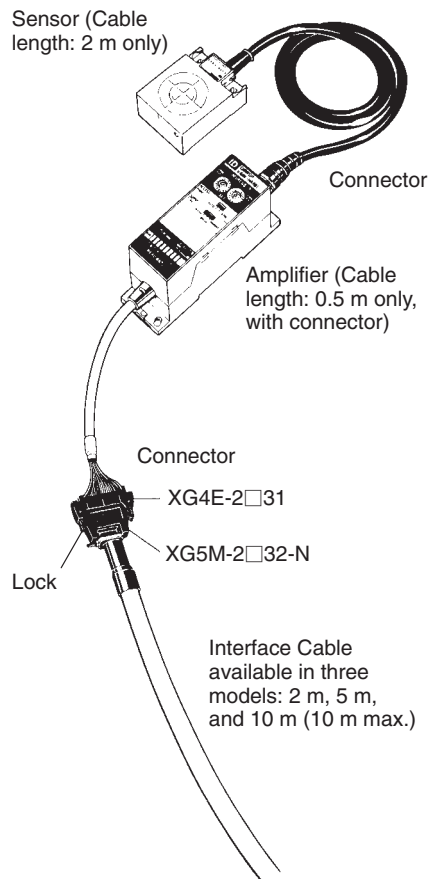

⚠ WARNING Always be sure to house the V600-HA□91/92 Amplifiers (including the cable and connector) in a control box. Exposure to water, oil, dust, metal powder, corrosive gases, or machine solvents may result in faulty operation, damage to the product or fire. When attaching the connector to a metal surface, always install an insulation board (thickness: 1.5 mm min.) between the connector and the metal to prevent short circuits.

4-1-4 Connecting Sensors

Hold the black part A of the connector, align the notch on the connector with the notch in the jack, and insert the connector until it snaps in.
 To disconnect the Sensor, pull portion B of the connector.

- Note**
1. When inserting the connector, always hold the molded section A. Pressing part B will not lock the connector.
 2. When disconnecting the connector, always hold part B and then pull it out.

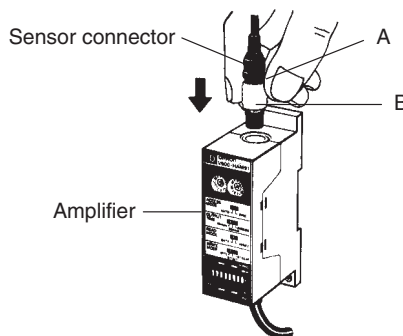

4-2 Installing Sensors

4-2-1 Installation Methods

V600-HS51 Sensor

The V600-HS51 Sensor is M12 in size. When the sensor is to be flush-mounted in metal, keep the transmission part (the tip of the coil) at least 15 mm away from the surrounding metal.

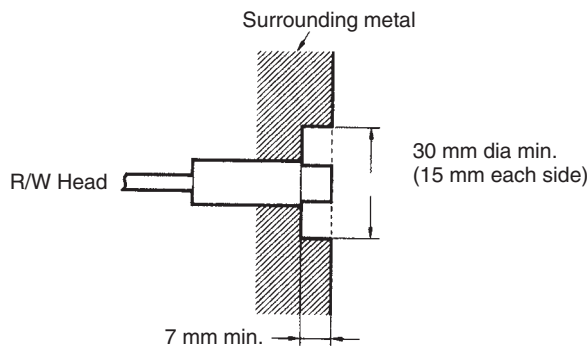

Note Mount the sensor so that its R/W Head is flush with or extending from the surrounding metal surface.

Mounting Sensors on Mounting Brackets

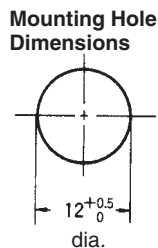

Note Slide the Sensor into a mounting bracket and secure them with the attached nuts and toothed lock washers. Tighten the nuts to a torque of 6 N • m (approximately 60 kgf • cm).

V600-HS61 Sensor

Secure the V600-HS61 Sensor with two M3 screws.

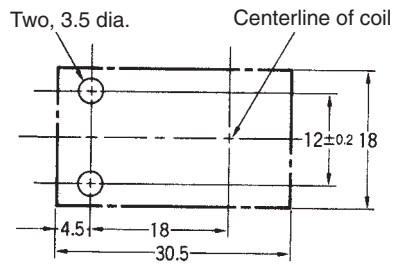
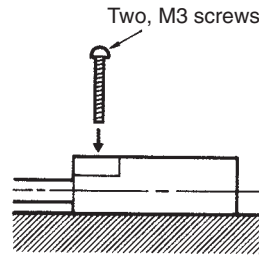

V600-HS63 Sensor

The V600-HS63 Sensor is provided with special nuts. It can be easily secured both from the front and rear.

Securing the V600-HS63 from the Front

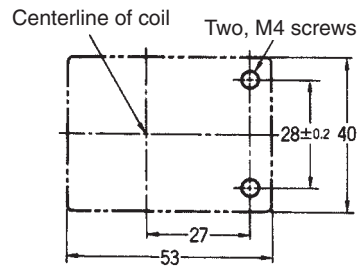
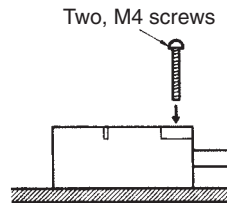

Note When securing the V600-HS63 from the front, remove the nuts.

Securing the V600-HS63 from the Rear

Insert the attached nuts in the sections indicated by arrow A.

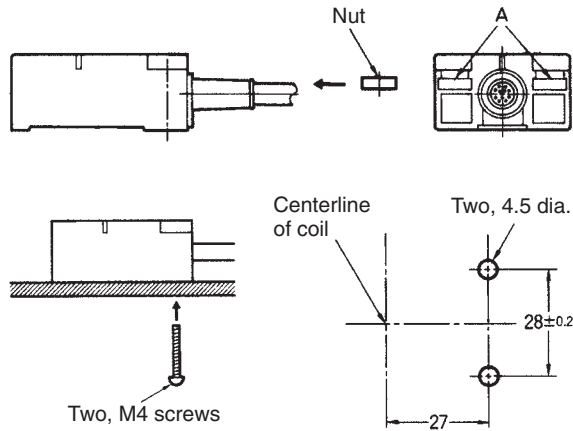

4-2-2 Effects of Surrounding Metal on Sensors

V600-HS51 Sensor

When the entire Sensor up to the coil surface is surrounded by metal without the recommended clearance (30 mm), the transmission distance is approximately 30% lower than the transmission distance (shown in 3-1-1) of the installation method shown in 4-2-1.

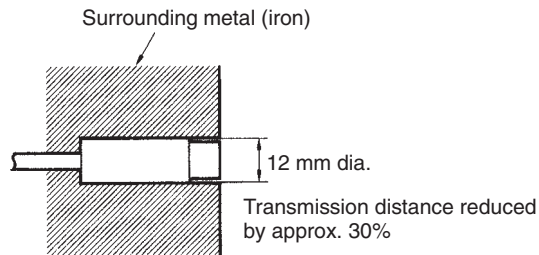

V600-HS61 Sensor

The Sensor can be surface-mounted and can also be embedded in metal to protect it from collision. If the Sensor is embedded in metal, keep the Sensor at least 15 mm away from the metal to prevent malfunctions. The metal surface must not be higher than the Sensor.

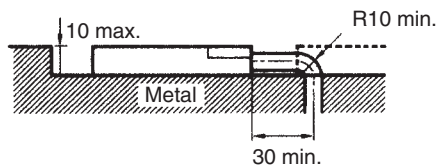

Unit: mm

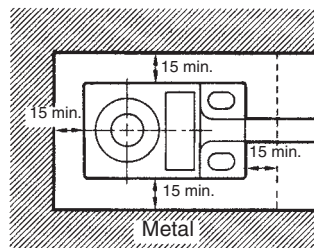

- Note**
1. The bend radius of the cable must be 10 mm or greater.
 2. If the distance between the Sensor and the metal is less than 15 mm, the transmission distance will be greatly shortened.

V600-HS63 Sensor

The Sensor can be surface-mounted and can also be embedded in metal to protect it from collision. If the Sensor is embedded in metal, keep the Sensor at least 30 mm away from the metal to prevent malfunctions. If the distance between the Sensor and the metal is less than 30 mm, the transmission distance will be greatly shortened. The metal surface must not be higher than the Sensor.

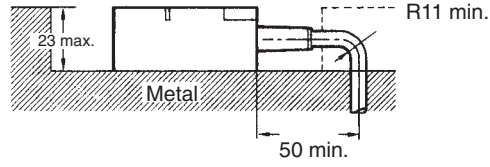

Unit: mm

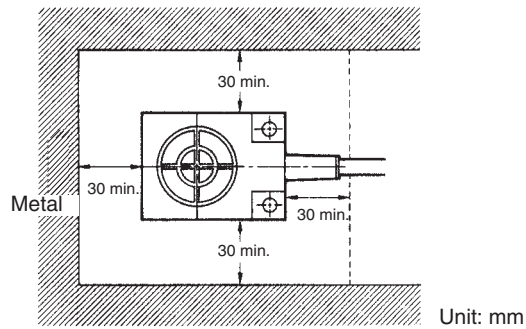

Unit: mm

- Note**
1. The bend radius of the cable must be 11 mm or greater.
 2. If the distance between the Sensor and the metal is less than 30 mm, the transmission distance will be greatly shortened.

4-2-3 Mutual Interference Between Sensors

When installing multiple Sensors, provide the distance shown below between Sensors to prevent malfunctions resulting from mutual interference.

V600-HS51 Sensors

Face-to-face Installation: 80 mm min.

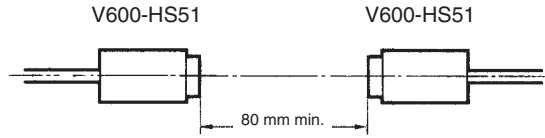

Side-by-side Installation: 80 mm min.

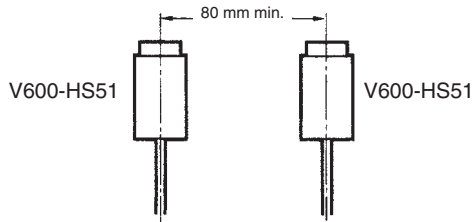

V600-HS61 Sensors

Face-to-face Installation: 80 mm min.

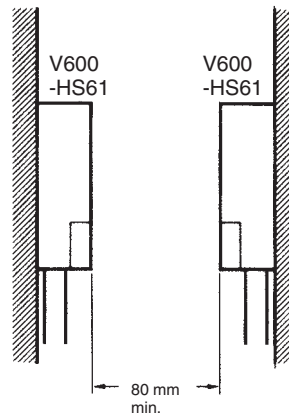

Side-by-side Installation: 80 mm min.

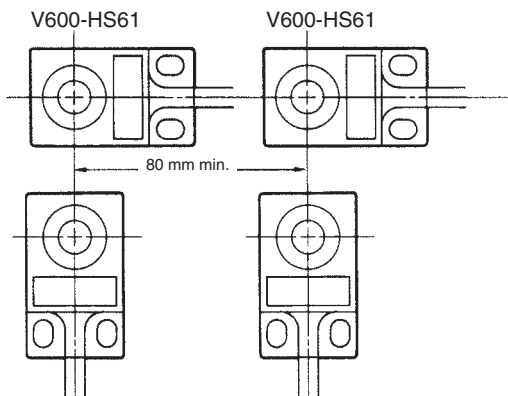

V600-HS63 Sensors

Face-to-face Installation: 200 mm min.

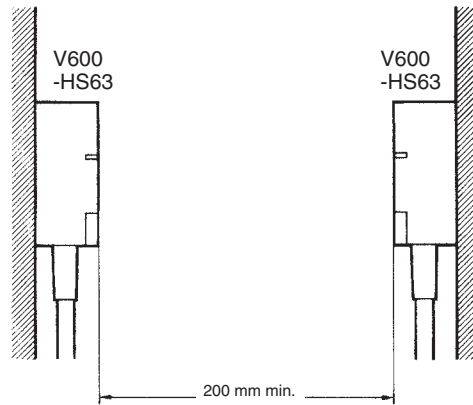

Side-by-side Installation: 200 mm min.

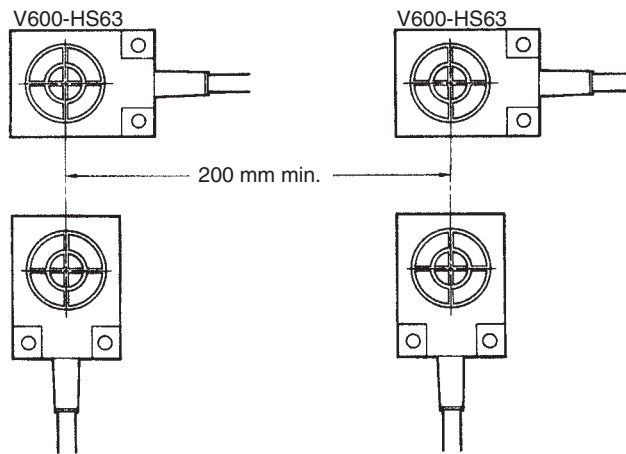

4-2-4 Mutual Interference Between Proximity Sensors and Sensors

The V600 Series uses an electromagnetic coupling method (530 kHz). If a Sensor is installed near a proximity sensor with an oscillation frequency of 400 to 600 kHz, the proximity sensor may malfunction. To prevent this, carefully select and install sensors by conducting tests in advance.

V600-HS51 Sensor

Mutual interference distance differs with the Sensor position relative to the proximity sensor. Provide the distance shown below between the Sensor and a proximity sensor.

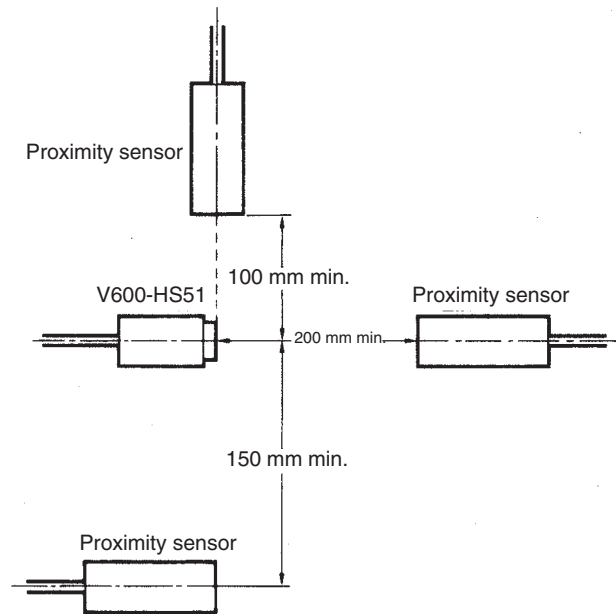

V600-HS61 Sensor

Provide the distance shown below between the Sensor and the proximity sensor.

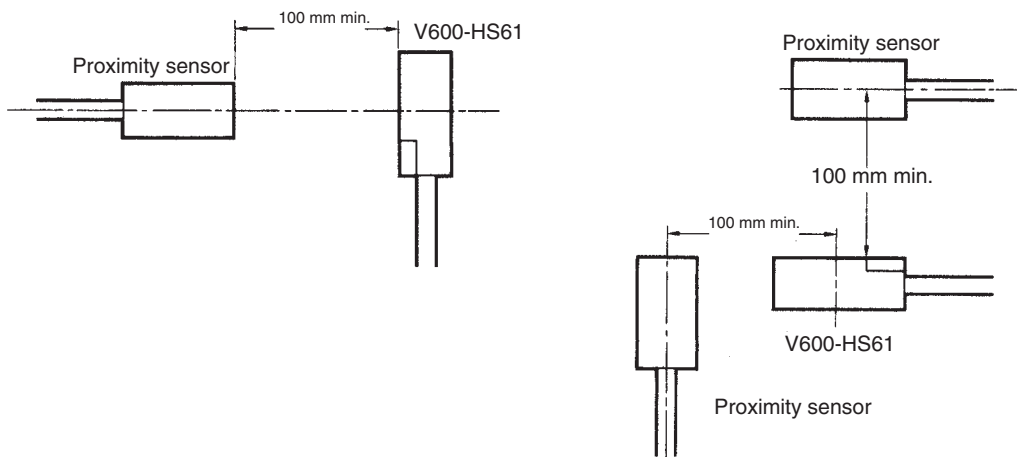

V600-HS63 Sensor

Provide the distance shown below between the Sensor and the proximity sensor.

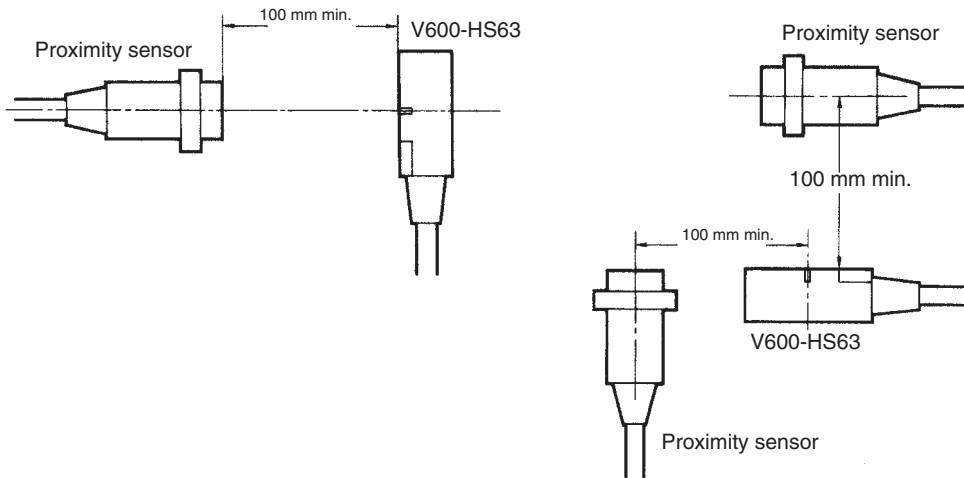

4-3 Installing Data Carriers

4-3-1 Installing EEPROM Data Carriers

V600-D23P71 and V600-D23P72 Data Carriers

We recommend that the optional Data Carrier Holder (V600-A84) be used to install the Data Carrier.

Installing Data Carriers with Data Carrier Holders

- 1, 2, 3... 1. Mount the Data Carrier Holder (V600-A84) on the pallet or container.

Securing the Holder with Screws

Secure the Holder with M3 flat head screws. Tighten the screws to a torque of 0.3 to 0.5 N/m (approximately 3 to 5 kgf/cm).

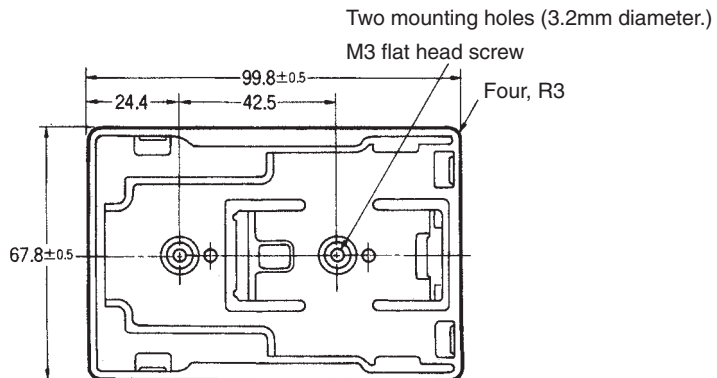

Securing the Holder by Ultrasonic Welding

If the Holder is to be mounted on a plastic packet or container, it can be welded by ultrasonic welding. In this case, each portion of the Holder can be welded in only a few seconds.

2. After mounting the Holder, insert the Data Carrier into both guides in the Holder and then slide it all the way in as shown below.

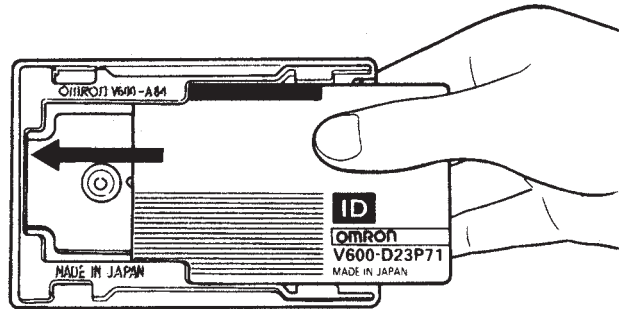

Effects of Metal on Transmission Distance

If there is metal at the back of the Data Carrier, the transmission distance will be shortened. To prevent this, always insert a non-metallic spacer (such as plastic or wood) between the Data Carrier and the metal. The relationship between the distance from the Data Carrier to the metal and the transmission distance is shown below.

V600-D23P71 Data Carriers

Transmission distance (100% when there is no metal at the back of Data Carrier): Y

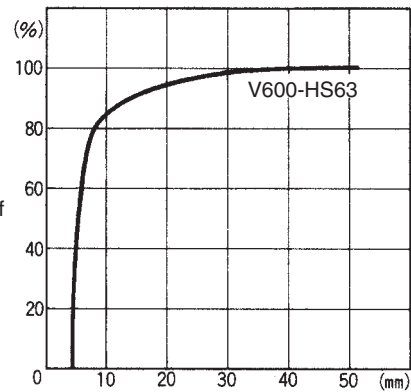

Distance between Data Carrier and metal: X

V600-D23P72 Data Carrier

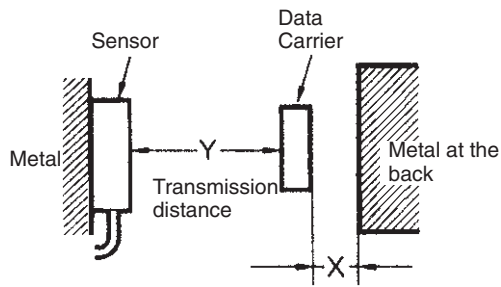
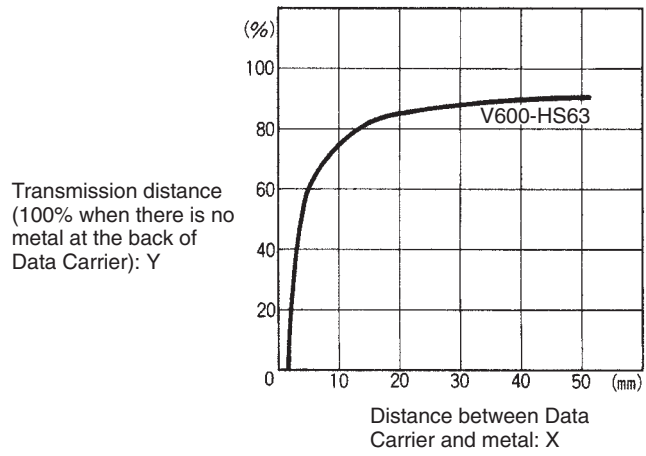

The distance between the Data Carrier and the metal can be adjusted using Data Carrier Holders, which can be stacked as shown in the following figure. Stacking two Holders facing in opposite directions will fix them together. The thickness of each Holder is 5 mm.

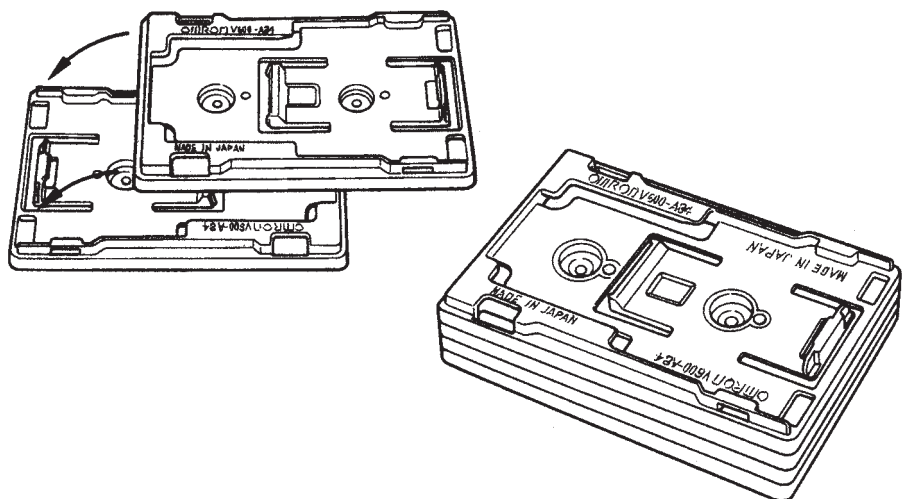

Effects of Inclination on Transmission Distance

Install the Data Carrier so that it is as parallel to the Sensor as possible. The Data Carrier does not necessarily have to be parallel to the Sensor, but the transmission distance will be shortened if it is not parallel. The following tables show the relationship between the inclination of the Data Carrier and the transmission distance.

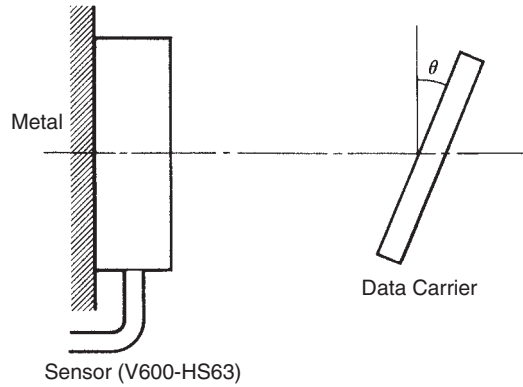

Inclination of V600-D23P71 Data Carrier and Transmission Distance

| Sensor | Inclination of Data Carrier (θ°) | | | | |
|-----------|--|----|----|----|-----|
| | 0 | 10 | 20 | 30 | 40 |
| V600-HS63 | 0% | 1% | 3% | 6% | 10% |

Inclination of V600-D23P72 Data Carrier and Transmission Distance

| Sensor | Inclination of Data Carrier (θ°) | | | | |
|-----------|--|----|----|----|----|
| | 0 | 10 | 20 | 30 | 40 |
| V600-HS63 | 0% | 3% | 4% | 5% | 7% |

Installation conditions: Sensor is surface-mounted on metal.
Data Carrier is surface-mounted on non-metal.

V600-D23P66 Data Carrier

Installation Method

Secure the Data Carrier with M3 flat head screws and washers. Tighten the screws to a torque of 0.3 to 0.5 N/m (approximately 3 to 5 kgf/cm).

The Data Carrier can be oriented in any direction and moved in any direction in reference to the Sensor.

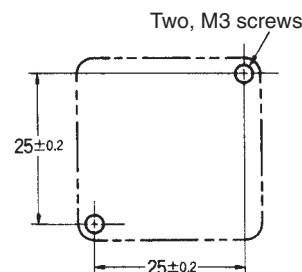

Effects of Metal on Transmission Distance

If there is metal at the back of the Data Carrier, the transmission distance will be shortened. To prevent this, always use an optional Data Carrier Attachment (V600-A86) or insert a non-metallic spacer (such as plastic or resin) between the Data Carrier and the metal. The relationship between the distance from the Data Carrier to the metal and the transmission distance is shown below. The Attachment is 10 mm thick, and multiple Attachments can be stacked.

Installing Data Carrier on V600-A86 Data Carrier Attachment

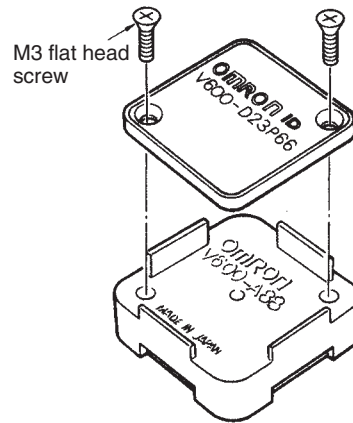

Note Install the Data Carrier on the Data Carrier Attachment so that their mounting holes are aligned with each other.

V600-D23P66 Data Carrier

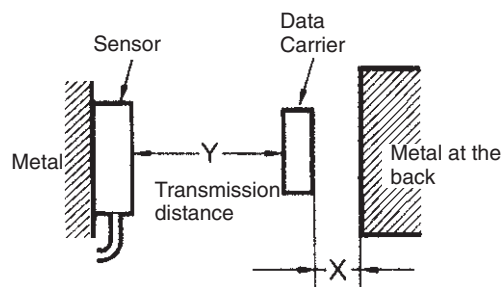
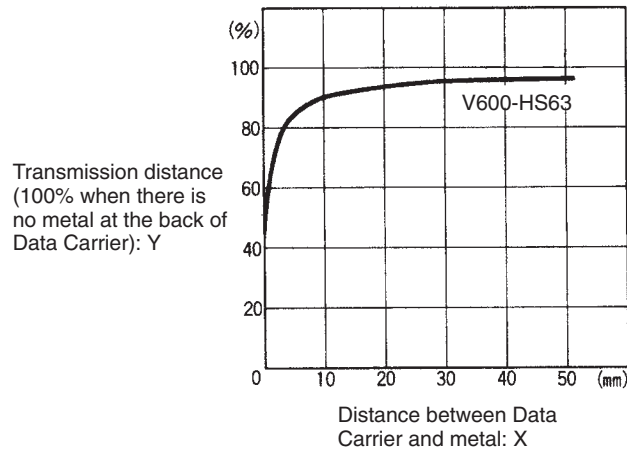

Effects of Inclination on Transmission Distance

Install the Data Carrier so that it is as parallel to the Sensor as possible. The Data Carrier does not necessarily have to be parallel to the Sensor, but the transmission distance will be shortened if it is not parallel. The following tables show the relationship between the inclination of the Data Carrier and the transmission distance.

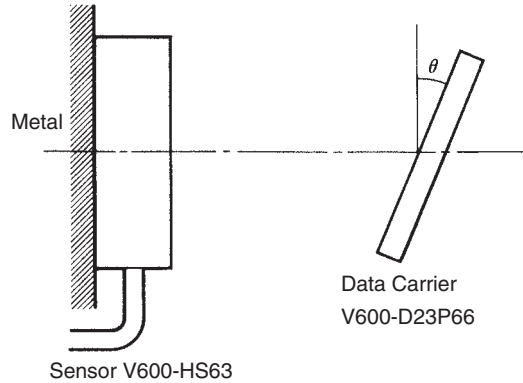

Inclination of V600-D23P66 Data Carrier and Transmission Distance

| Sensor | Inclination of Data Carrier (θ°) | | | | |
|-----------|--|----|----|----|----|
| | 0 | 10 | 20 | 30 | 40 |
| V600-HS63 | 0% | 2% | 2% | 3% | 5% |

Installation conditions: Sensor is surface-mounted on metal.
Data Carrier is surface-mounted on non-metal.

V600-D23P66SP Data Carrier

Installation Method

Secure the Data Carrier with M5 screws and washers. Tighten the screws to a torque of 1.2 N/m (approximately 12 kgf/cm).

The Data Carrier can be oriented in any direction and moved in any direction in reference to the Sensor.

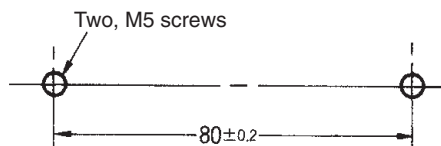

Effects of Metal on Transmission Distance

If there is metal at the back of the Data Carrier, the transmission distance will be shortened. To prevent this, always insert a non-metallic spacer (such as plastic or resin) between the Data Carrier and the metal. The relationship between the distance from the Data Carrier to the metal and the transmission distance is shown below.

V600-D23P66SP Data Carrier

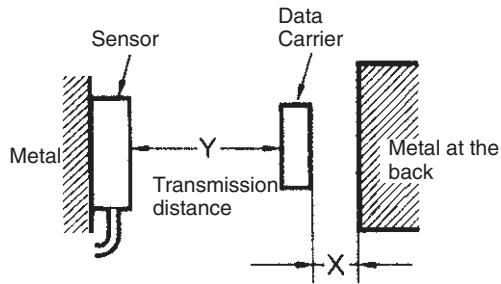
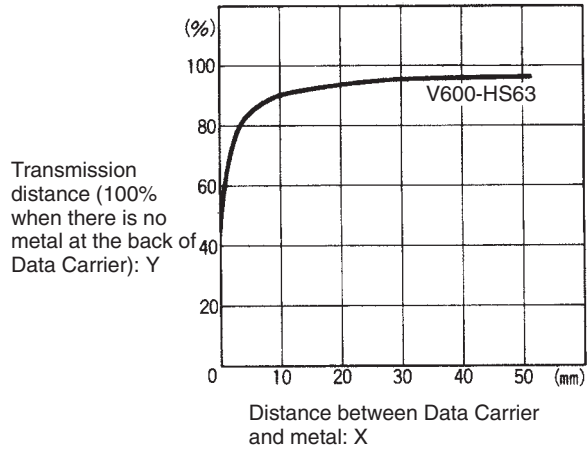

Effects of Inclination on Transmission Distance

Install the Data Carrier so that it is as parallel to the Sensor as possible. The Data Carrier does not necessarily have to be parallel to the Sensor, but the transmission distance will be shortened if it is not parallel. The following tables show the relationship between the inclination of the Data Carrier and the transmission distance.

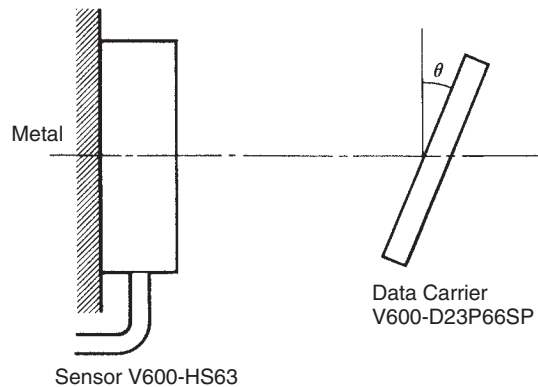

Inclination of V600-D23P66SP Data Carrier and Transmission Distance

| Sensor | Inclination of Data Carrier (θ°) | | | | |
|----------|--|----|----|----|----|
| | 0 | 10 | 20 | 30 | 40 |
| V600-H11 | 0% | 2% | 2% | 3% | 5% |

Installation conditions: Sensor is surface-mounted on metal.
Data Carrier is surface-mounted on non-metal.

V600-D23P61 Data Carrier

Installation Method

Secure the Data Carrier with M3 flat head screws and washers. Tighten the screws to a torque of 0.3 to 0.5 N/m (approximately 3 to 5 kgf/cm).

The Data Carrier can be oriented in any direction and moved in any direction in reference to the Sensor.

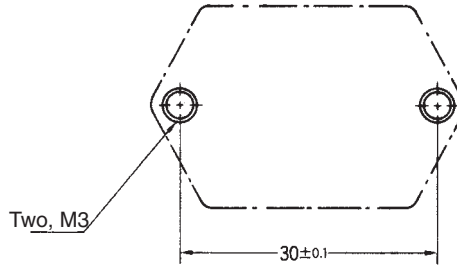

Effects of Surrounding Metal on Transmission Distance

If the Data Carrier is surrounded by metal as shown in B, the transmission distance is approximately 10% lower than when the Data Carrier is surface-mounted on metal as shown in A. The transmission distance shown in Section 3-1 is applicable when the Data Carrier is surface-mounted on metal (iron) as in A.

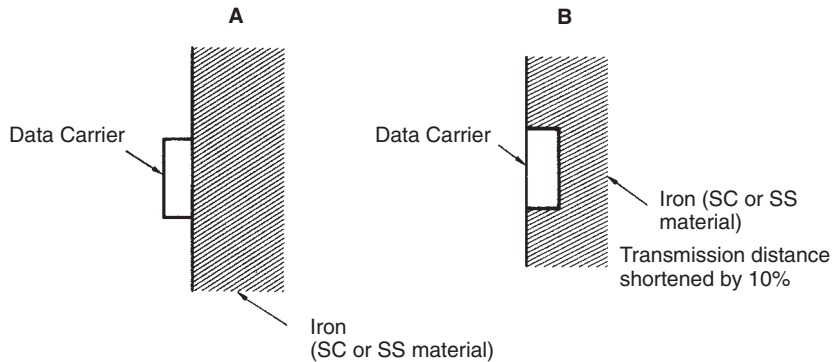

Effects of Type of Surrounding Metal

The transmission distance differs with the type of surrounding metal, as shown in the table.

| Data Carrier | Iron | SUS | Brass | Aluminum |
|--------------|------|-----|-------|----------|
| V600-D23P61 | 100% | 95% | 95% | 95% |

Note The transmission distance is set to 100% when surrounding metal is iron.

Effects of Inclination on Transmission Distance

Install the Data Carrier so that it is as parallel to the Sensor as possible. The Data Carrier does not necessarily have to be parallel to the Sensor, but the transmission distance will be shortened if it is not parallel. The following tables show the relationship between the inclination of the Data Carrier and the transmission distance.

Inclination of V600-D23P61 Data Carrier and Transmission Distance

| Sensor | Inclination of Data Carrier (θ°) | | | | |
|-----------|--|----|-----|-----|------|
| | 0 | 10 | 20 | 30 | 40 |
| V600-HS63 | 0% | 5% | 14% | 23% | 100% |

V600-D23P53 and V600-D23P54 Data Carriers

Installation Method

- Install the Data Carrier according to the mounting dimensions shown below.
- Use a two-liquid epoxy adhesive to secure the Data Carrier.

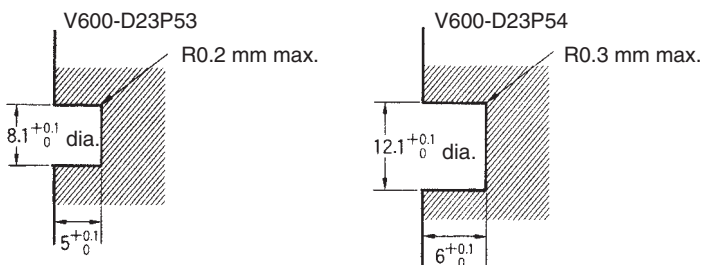

Effects of Type of Surrounding Metal on Transmission Distance

- The transmission distance differs with the material of surrounding or contact metal as shown below.

| Data Carrier | Iron | SUS | Brass | Aluminum |
|----------------------|------|------------|------------|------------|
| V600-D23P53 (Dia.8) | 100% | 70% to 80% | 55% to 70% | 55% to 70% |
| V600-D23P54 (Dia.12) | 100% | 85% to 90% | 80% to 85% | 80% to 85% |

Note The transmission distance is set to 100% when surrounding or contact metal is iron

- The transmission distance is increased by at least 10% when the Data Carrier is flush-mounted in or surface-mounted on non-metal.

Effects of Inclination on Transmission Distance

Install the Data Carrier so that it is as parallel to the Sensor as possible. The Data Carrier does not necessarily have to be parallel to the Sensor, but the transmission distance will be shortened if it is not parallel. The following tables show the relationship between the inclination of the Data Carrier and the transmission distance.

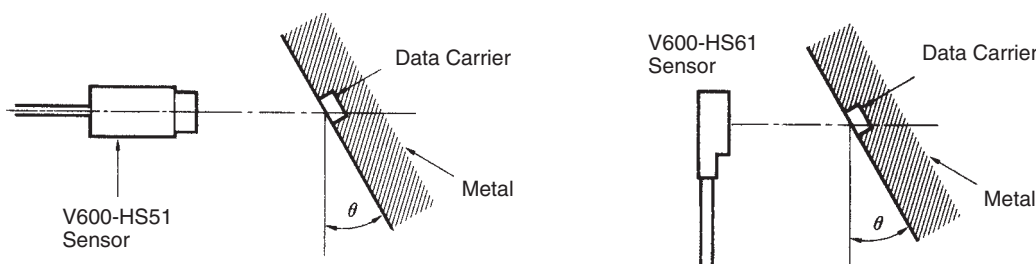

Inclination of V600-D23P53 Data Carrier and Transmission Distance

| V600-D23P53 Data Carrier | Inclination of Data Carrier (θ°) | | | | |
|--------------------------|----------------------------------|----|-----|-----|-----|
| | 0 | 10 | 20 | 30 | 40 |
| V600-HS51/HS61 Sensor | 0% | 8% | 16% | 30% | 60% |

Inclination of V600-D23P54 Data Carrier and Transmission Distance

| V600-D23P54 Data Carrier | Inclination of Data Carrier (θ°) | | | | |
|--------------------------|----------------------------------|----|----|-----|-----|
| | 0 | 10 | 20 | 30 | 40 |
| V600-HS51/HS61 Sensor | 0% | 4% | 8% | 16% | 30% |

4-3-2 Installing SRAM Data Carriers

V600-D8KR12D, V600-D8KR13, and V600-D8KR04 Data Carriers

Installation Method

- Secure the Data Carrier with M4 screws and spring washers. Tighten the screws to a torque of 0.7 to 1.2 N/m (approximately 7 to 12 kgf/cm).
- The Data Carrier can be oriented in any direction and moved in any direction in reference to the Sensor.

V600-D8KR12D Data Carrier

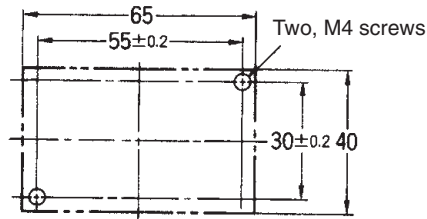

V600-D8KR13 Data Carrier

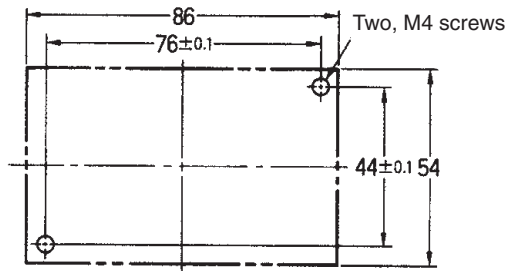

V600-D8KR04 Data Carrier

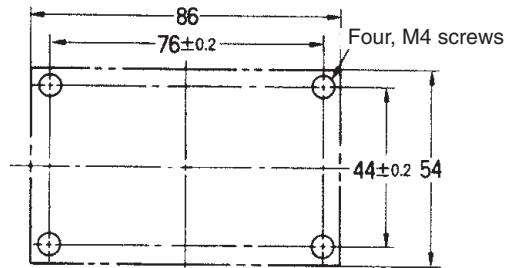

Installing Data Carriers on Metal

V600-D8KR12D and V600-D8KR13 Data Carriers

The V600-D8KR12D and V600-D8KR13 Data Carriers can be surface-mounted on metal and can also be flush-mounted in metal. When the Data Carrier is flush-mounted in metal, the metal surface must not be higher than the Data Carrier.

V600-D8KR12D Data Carriers

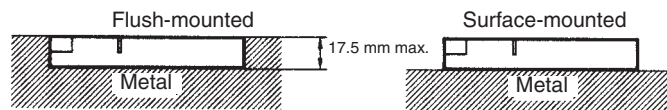

V600-D8KR13 Data Carriers

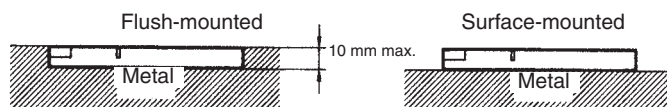

V600-D8KR04 Data Carriers The V600-D8KR04 can be surface-mounted on metal and can also be flush-mounted in metal. When the Data Carrier is flush-mounted in metal, the transmission distance is greatly affected by the distance (x) between the Data Carrier and the metal.

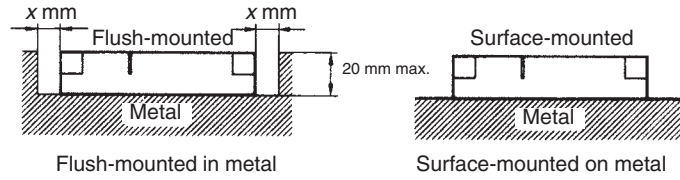

Combination with V600-HS63 Sensor

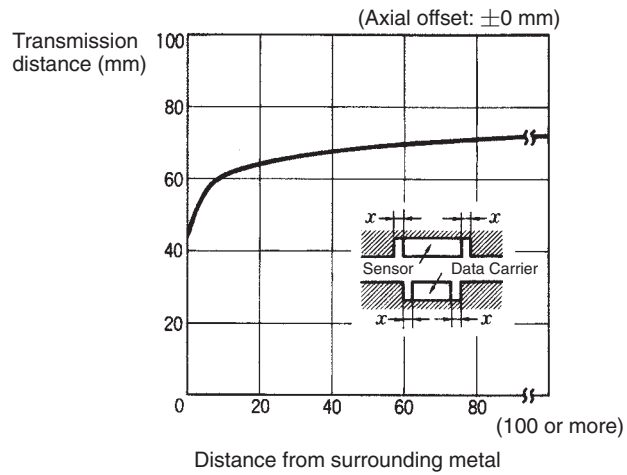

Effects of Inclination on Transmission Distance

Install the Sensor and the Data Carrier so that angle θ does not exceed 10° , as shown below.

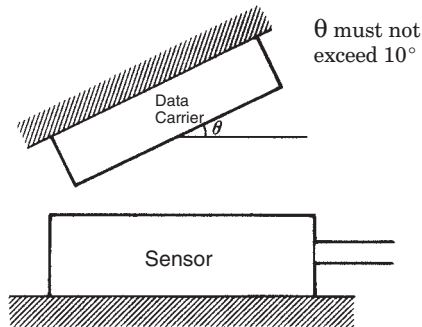

V600-D2KR16 Data Carrier

Installation Method

Use an optional Data Carrier Holder (V600-A81) to install the V600-D2KR16. Secure the Holder with at least two M3 flat head screws. Tighten the screws to a torque of 0.3 to 0.5 N/m (approximately 3 to 5 kgf/cm). Slide the Data Carrier into the Holder.

Always attach the battery replacement cover seal to the back of the Data Carrier. Without this seal, the enclosure rating does not comply with IP50.

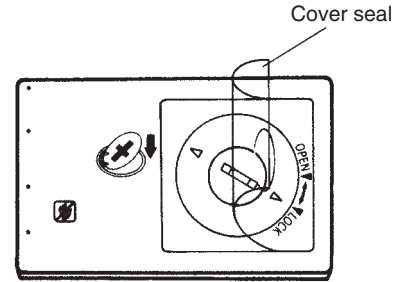
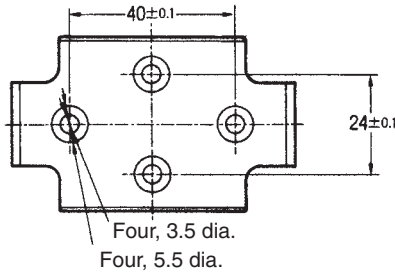

Installing Data Carriers on Metal

The Data Carrier can be flush-mounted in metal or surface-mounted on metal. If it is mounted as shown in the figure below, the transmission distance will not be affected.

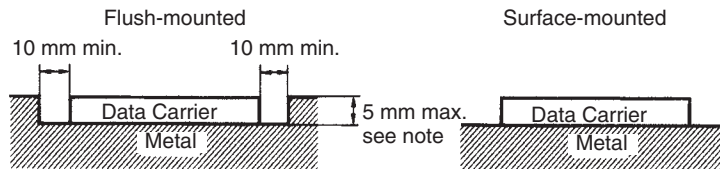

Note This height is 9 mm max. when the V600-A81 Holder is used.

Effects of Inclination on Transmission Distance

Install the Sensor and the Data Carrier so that angle θ does not exceed 10° , as shown below.

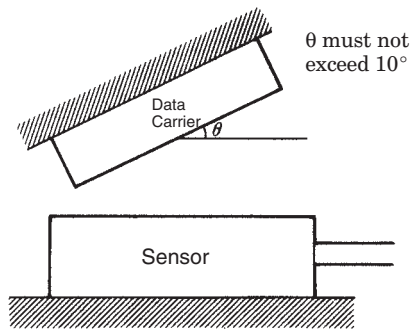

SECTION 5

Communications with Hosts

This section provides details of communications with hosts, including timing charts and operation outlines for each Intelligent Flag Amplifier which communicates with a host.

| | | |
|-------|---|-----|
| 5-1 | Introduction | 84 |
| 5-2 | V600-HAR91/-HAR81 Intelligent Flag 8-bit Amplifier for Read Data Output | 84 |
| 5-2-1 | Read Operation in AUTO Mode | 84 |
| 5-2-2 | Read Operation in SYNC Mode | 86 |
| 5-3 | V600-HAM91/-HAM81 Intelligent Flag 8-bit Amplifier with Versatile Functions | 88 |
| 5-3-1 | Read Operation in AUTO Mode | 88 |
| 5-3-2 | Read Operation in SYNC Mode | 92 |
| 5-3-3 | Write Operation in AUTO Mode | 96 |
| 5-3-4 | Write Operation in SYNC Mode | 97 |
| 5-4 | V600-HAR92 Intelligent Flag II 16-bit Amplifier for Read Data Output | 99 |
| 5-4-1 | OUTPUT MODE 1: Standard Mode | 99 |
| 5-4-2 | OUTPUT MODE 2: Wiring Saving Mode | 103 |
| 5-5 | Sample Programming for Host | 108 |

5-1 Introduction

The Intelligent Flag and Intelligent Flag II Amplifiers can be connected to hosts, such as Programmable Controllers, I/O Terminals, the B7A Series, and the CompoBus/D. This section presents the timing charts and operation outlines for the Intelligent Flag Amplifiers which communicate with a host. Write a communications program for the host according to the timing charts shown in this section.

| Amplifier | Operation outline | | Page |
|---|-----------------------------------|-----------------------------|------|
| V600-HAR91/-HAR81 Intelligent Flag 8-bit Amplifier for Read Data Output | Read operation in AUTO mode | | 84 |
| | Read operation in SYNC mode | | 86 |
| V600-HAM91/-HAM81 Intelligent Flag 8-bit Amplifier with Versatile Functions | Read operation in AUTO mode | DATA read | 88 |
| | | VERIFY read | 90 |
| | Read operation in SYNC mode | DATA read | 92 |
| | | VERIFY read | 94 |
| | Write operation in AUTO mode | BYTE mode | 96 |
| | | BIT SET mode | |
| | | BIT CLR mode | |
| | Write operation in SYNC mode | BYTE mode | 97 |
| BIT SET mode | | | |
| BIT CLR mode | | | |
| V600-HAR92 Intelligent Flag II 16-bit Amplifier for Read Data Output | OUTPUT MODE 1: standard mode | Read operation in AUTO mode | 99 |
| | | Read operation in SYNC mode | 102 |
| | OUTPUT MODE 2: wiring saving mode | Read operation in AUTO mode | 104 |
| | | Read operation in SYNC mode | 106 |

5-2 V600-HAR91/-HAR81 Intelligent Flag 8-bit Amplifier for Read Data Output

5-2-1 Read Operation in AUTO Mode

System Configuration in AUTO Mode

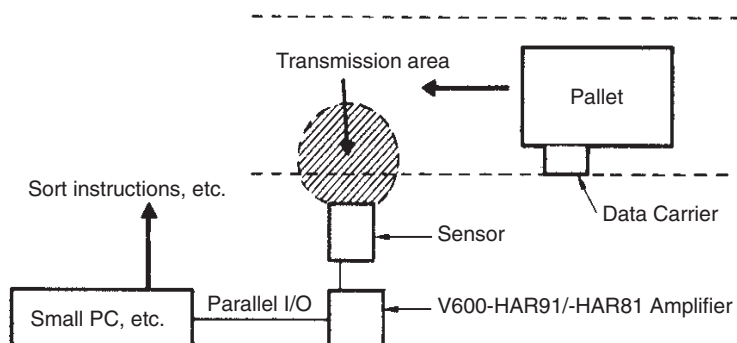

Timing Chart

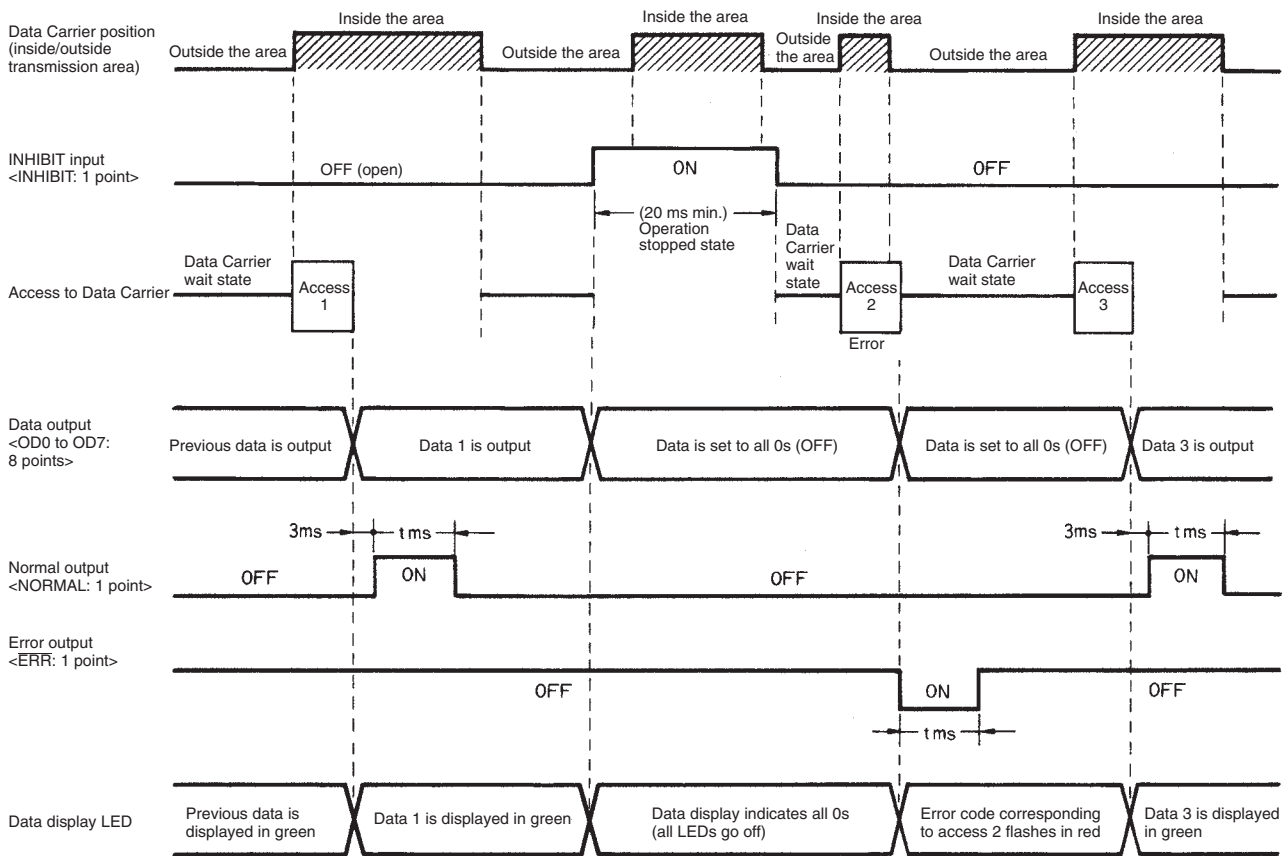

Normal Operation

- 1, 2, 3...
1. When turned on, the Amplifier waits for a Data Carrier.
 2. The Amplifier begins to access a Data Carrier and read data from it when a Data Carrier enters the transmission area.
 3. The Amplifier outputs read data to the eight data output lines (OD0 to OD7). The data indicators also light.
 4. The normal output signal is turned ON 3 ms after read data is output to the data output lines. It remains ON for the time (t ms) specified by the output time setting switch.

Note When the INHIBIT input signal is turned ON, the normal output signal is unconditionally cleared even if it is still within the specified time range. This also applies when the output time setting switch is set to CONTINUOUS (infinite).

5. The data output lines remain in the same state until the next data is output. If, however, the INHIBIT input signal is turned ON or an error occurs, all the data output lines are unconditionally set to 0 (OFF).

When Errors Occur

Normally, an error occurs in AUTO mode when the Data Carrier is traveling so fast that the Data Carrier moves out of the transmission area when the Amplifier is still accessing the Data Carrier.

- 1, 2, 3...
1. When an error occurs, the error output signal remains ON for the time (t ms) specified by the output time setting switch. (The error output signal also serves as a RUN output signal when the signal level is low.)

Note When the INHIBIT input signal is turned ON, the error output signal is unconditionally cleared even if it is still within the specified time range. This also applies when the output time setting switch is set to CONTINUOUS (infinite).

2. When an error occurs, all the eight data output lines (OD0 to OD7) are simultaneously set to 0 (OFF).

Instructions Before Use

- 1, 2, 3...
 1. The INHIBIT input signal must be turned ON for at least 20 ms.
 2. Read data must be fetched by turning ON the normal output signal (NORMAL).
 3. If the Data Carrier remains stopped within the transmission area in AUTO mode, the battery life will be extremely shortened. To prevent this, turn ON the INHIBIT input signal to stop the Sensor from oscillating when the Data Carrier remains stopped within the transmission area after output data is fetched.

5-2-2 Read Operation in SYNC Mode

System Configuration in SYNC Mode

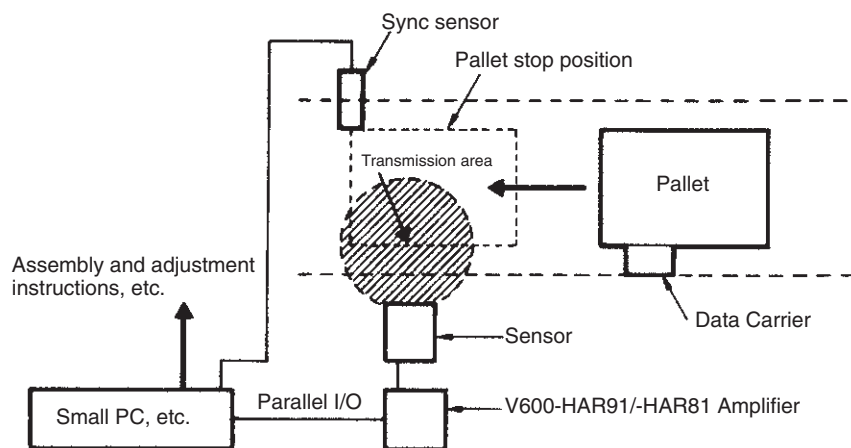

Timing Chart

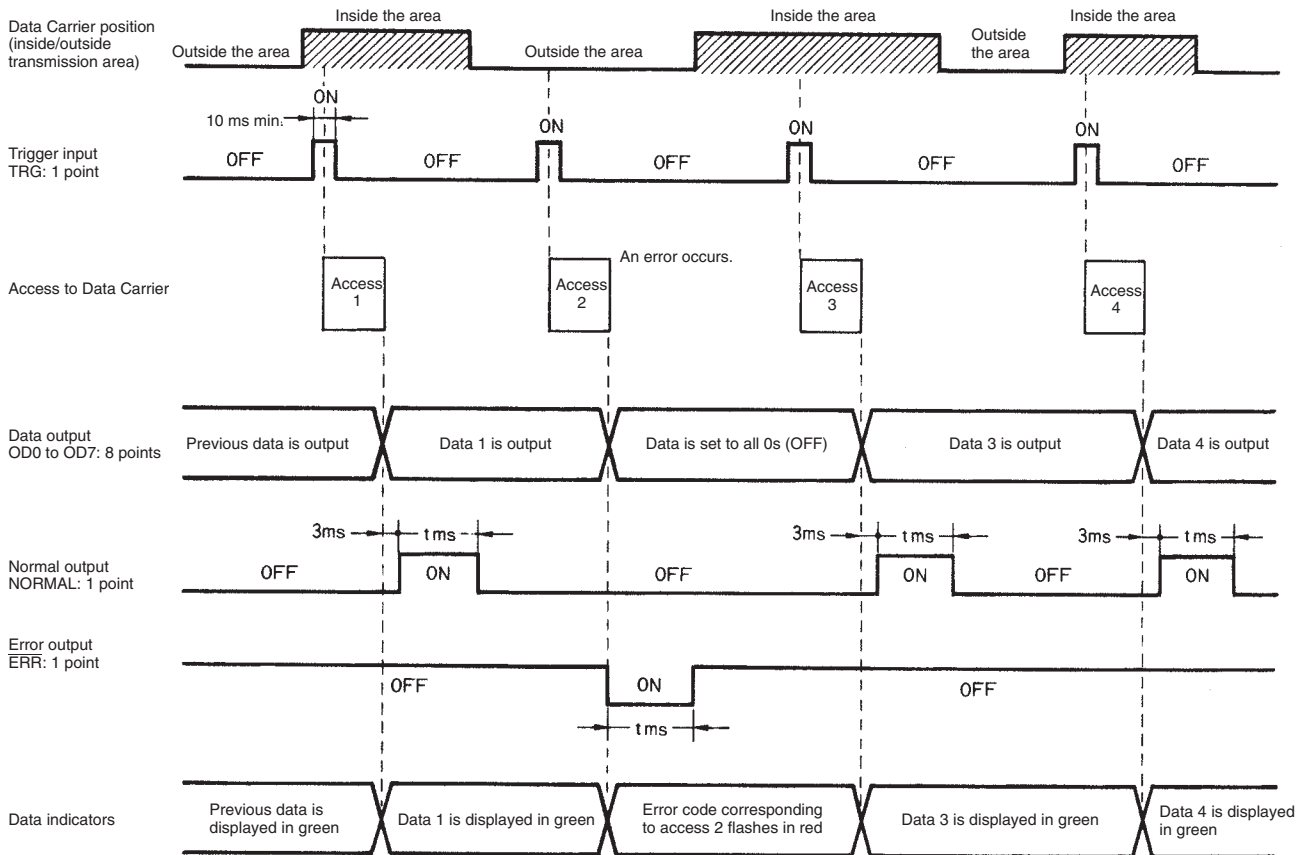

Normal Operation

- 1, 2, 3...**
1. Turn on the Amplifier.
 2. Turn ON the trigger input signal when a Data Carrier is in the transmission area. (This signal must be turned ON for at least 10 ms.)
 3. When the trigger input signal is turned ON, the Amplifier begins to access a Data Carrier and read data from it.
 4. The Amplifier outputs read data to the eight data output lines (OD0 to OD7). The data indicators also light.
 5. The normal output signal is turned ON 3 ms after read data is output to the data output lines. It remains ON for the time (t ms) specified by the output time setting switch.
 6. The data output lines remain in the same state until the next data is output.

When Errors Occur

Normally, an error occurs in SYNC mode if the trigger input signal is turned ON when no Data Carrier is in the transmission area.

- 1, 2, 3...**
1. If the trigger input signal is turned ON when no Data Carrier is in the transmission area, this situation is treated as a "No Data Carrier" error.
 2. The error output signal remains ON for the time (t ms) specified by the output time setting switch. (The error output signal also serves as a RUN output signal when the signal level is low.)
 3. All the eight data output lines (OD0 to OD7) are simultaneously set to 0 (OFF). The error indicator lights in red. The data indicators flash an error code in red. They stop flashing at the next access.

Instructions Before Use

- 1, 2, 3...**
1. The trigger input signal (TRG) must remain ON for at least 10 ms.

2. Read data must be fetched by turning ON the normal output signal (NORMAL).
3. If the output time setting switch is set to CONTINUOUS (infinite), the normal output signal or error output signal remains in the same state until the next trigger input signal is turned on.

5-3 V600-HAM91/-HAM81 Intelligent Flag 8-bit Amplifier with Versatile Functions

5-3-1 Read Operation in AUTO Mode

There are two read modes in AUTO mode: DATA read and VERIFY read modes. In DATA read mode, 8-bit data is read and output. In VERIFY read mode, data actually read from the Data Carrier is verified against preset 8-bit data and this verification result is output.

DATA Read Mode

Timing Chart

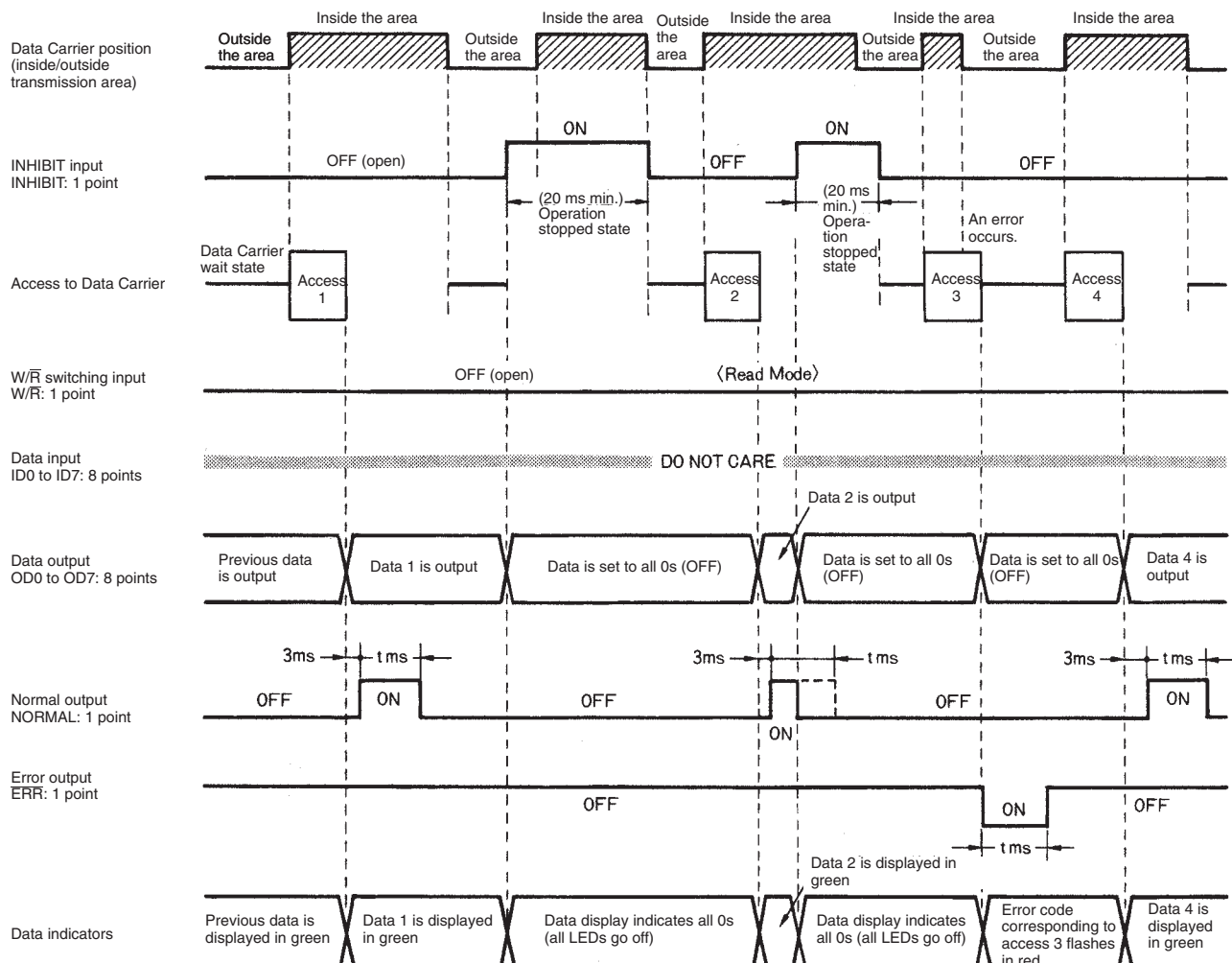

Normal Operation

- 1, 2, 3... 1. Turn the Amplifier on.
2. Switch the W/R switching input line to Read Mode (OFF: open).

Note At least 5 ms is required to fetch data after the W/R switching input line is switched to Read Mode.

3. Set the INHIBIT input line to OFF (open).
4. Data in the eight data input lines (ID0 to ID7) is all ignored, so no data setting is required.
5. In AUTO mode, the Amplifier simultaneously enters a Data Carrier wait state when being turned on.
6. The Amplifier begins to access a Data Carrier and read data from it when the Data Carrier enters the transmission area.
7. The Amplifier outputs read data to the eight data output lines (OD0 to OD7). The data indicators also light.
8. The normal output signal is turned on 3 ms after read data is output to the data output lines. It remains on for the time (t ms) specified by the output time setting switch.

Note When the INHIBIT input signal is turned on, the normal output signal is unconditionally cleared even if it is still within the specified time range. This also applies when the output time setting switch is set to CONTINUOUS (infinite).

9. The data output lines remain in the same state until the next data is output. However, if the INHIBIT input signal is turned on or an error occurs, all the data output lines are unconditionally set to 0 (OFF).

When Errors Occur

Normally, an error occurs in AUTO mode when the Data Carrier is traveling so fast that the Data Carrier moves out of the transmission area when the Amplifier is still accessing the Data Carrier.

- 1, 2, 3...** 1. When an error occurs, the error output signal remains ON for the time (t ms) specified by the output time setting switch. (The error output signal also serves as a RUN output signal when the signal level is low.)

Note When the INHIBIT input signal is turned on, the error output signal is unconditionally cleared even if it is still within the specified time range. This also applies when the output time setting switch is set to CONTINUOUS (infinite).

2. When an error occurs, all the eight data output lines (OD0 to OD7) are simultaneously set to 0 (OFF). The error indicator lights in red. The data indicators flash an error code in red. They stop flashing at the next access.

Instructions Before Use

- 1, 2, 3...** 1. When switching the W/\bar{R} switching line, always wait at least 5 ms before starting the next processing.
2. The INHIBIT input signal must remain ON for at least 20 ms.
3. Read data must be fetched by turning ON the normal output signal (NORMAL).
4. If the Data Carrier remains stopped within the transmission area in AUTO mode, the battery life will be extremely shortened. To prevent this, turn the INHIBIT input signal on to stop the Sensor from oscillating when the Data Carrier remains stopped within the transmission area after output data is fetched.

VERIFY Read Mode

Timing Chart

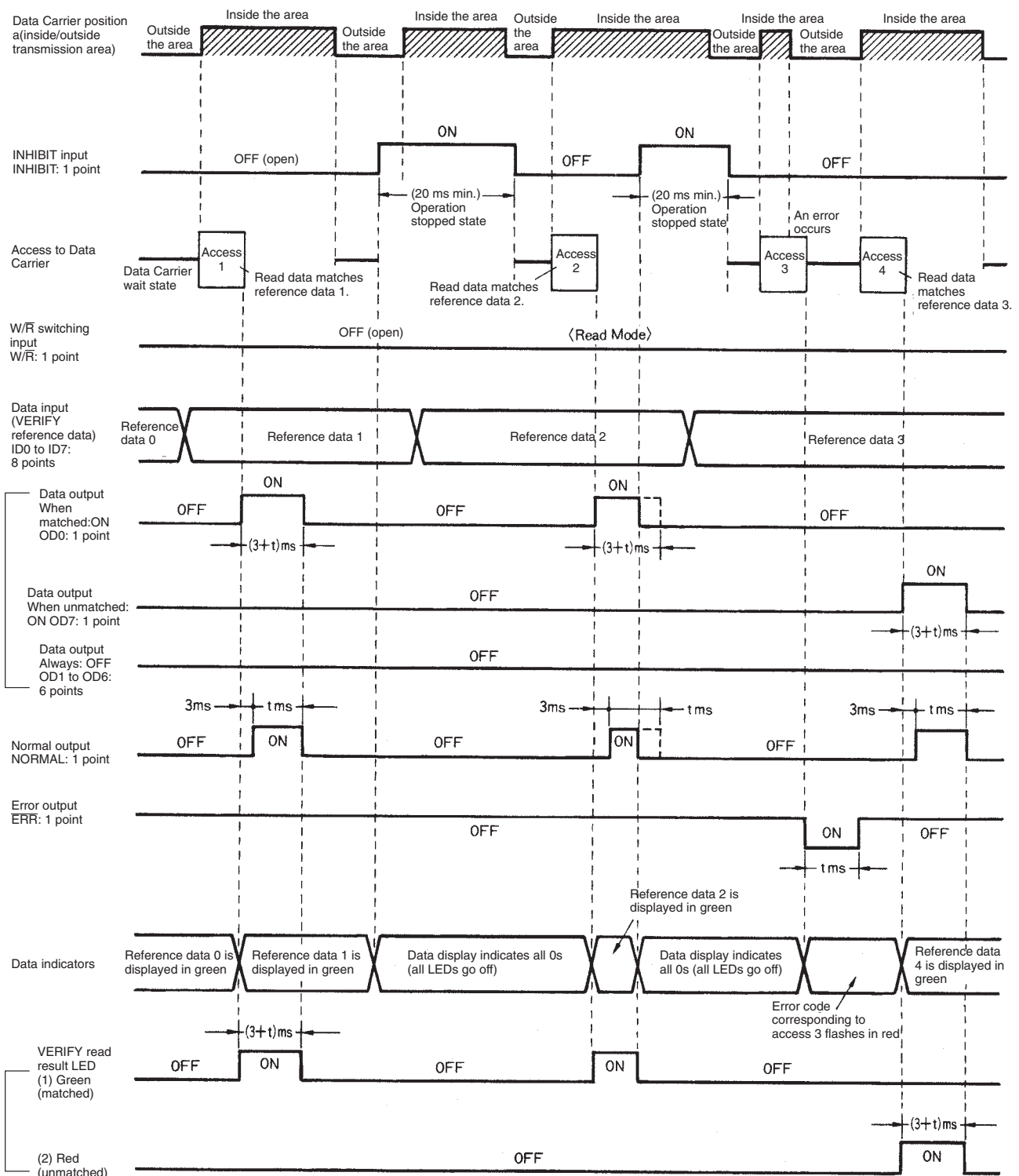

Normal Operation

- 1, 2, 3... 1. Turn the Amplifier on.
2. Switch the $\overline{W/R}$ switching input line to Read Mode (OFF: open).

Note At least 5 ms is required to fetch data after the $\overline{W/R}$ switching input line is switched to Read Mode.

3. Set the INHIBIT input line to OFF (open).
4. Enter VERIFY reference data into the eight data input lines (ID0 to ID7).
Example: When VERIFY reference data is 55_H

| ID7 | ID6 | ID5 | ID4 | ID3 | ID2 | ID1 | ID0 |
|------------|-----------|------------|-----------|------------|-----------|------------|-----------|
| 0 (OFF) | 1 (ON) | 0 (OFF) | 1 (ON) | 0 (OFF) | 1 (ON) | 0 (OFF) | 1 (ON) |

At this stage, the data indicators still indicate the previous reference data.

5. In AUTO mode, the Amplifier simultaneously enters a Data Carrier wait state when being turned on.
6. The Amplifier begins to access a Data Carrier and read data from it when the Data Carrier enters the transmission area. When the Amplifier accesses the Data Carrier, the data indicators indicate the new reference data.
7. The amplifier automatically compares the read data with the reference data. If the read data matches the reference data, data output line OD0 is turned on and the VERIFY read result LED lights in green (OK). If the read data does not match the reference data, data output line OD7 is turned on and the VERIFY read result LED lights in red (NG). In both cases above, data output lines OD1 to OD6 are always set to OFF.
8. The normal output signal is turned on 3 ms after read data is output to the data output lines. It remains ON for the time (t ms) specified by the output time setting switch.

Note When the INHIBIT input signal is turned on, the normal output signal is unconditionally cleared even if it is within the specified time range. This also applies when the output time setting switch is set to CONTINUOUS (infinite).

9. In VERIFY read mode, the data output lines are simultaneously turned OFF when the normal output signal is turned on. Also, if the INHIBIT input signal is turned on or an error occurs, all the data output lines are unconditionally set to 0 (OFF). All the data indicators are switched to 0 (OFF).

When Errors Occur

Normally, an error occurs in AUTO mode when the Data Carrier is traveling so fast that the Data Carrier moves out of the transmission area when the Amplifier is still accessing the Data Carrier.

- 1, 2, 3... 1. When an error occurs, the error output signal remains ON for the time (t ms) specified by the output time setting switch. (The error output signal also serves as a RUN output signal when the signal level is low.)

Note When the INHIBIT input signal is turned on, the error output signal is unconditionally cleared even if it is still within the specified time range. This also applies when the output time setting switch is set to CONTINUOUS (infinite). All the data indicators are switched to 0 (OFF).

2. When an error occurs, all the eight data output lines (OD0 to OD7) are simultaneously set to 0 (OFF). In VERIFY read mode, data output lines OD1 to OD6 are always set to 0 (OFF) regardless of error occurrence.
3. When an error occurs, the error indicator lights in red. The data indicators flash an error code in red. They stop flashing at the next access.

Instruction Before Use

- 1, 2, 3... 1. When switching the W/\bar{R} switching line, always wait at least 5 ms before starting the next processing.
2. The INHIBIT input signal must remain ON for at least 20 ms.
3. To ensure data integrity, the data input lines must be switched at least 10 ms before the Amplifier accesses the Data Carrier.

4. Read data must be fetched by turning ON the normal output signal (NORMAL).
5. If the Data Carrier remains stopped within the transmission area in AUTO mode, the battery life will be extremely shortened. To prevent this, turn the INHIBIT input signal on to stop the Sensor from oscillating when the Data Carrier remains stopped within the transmission area after output data is fetched.

5-3-2 Read Operation in SYNC Mode

As in AUTO mode, read operation in SYNC mode is also divided into DATA read and VERIFY read modes.

DATA Read Mode

Timing Chart

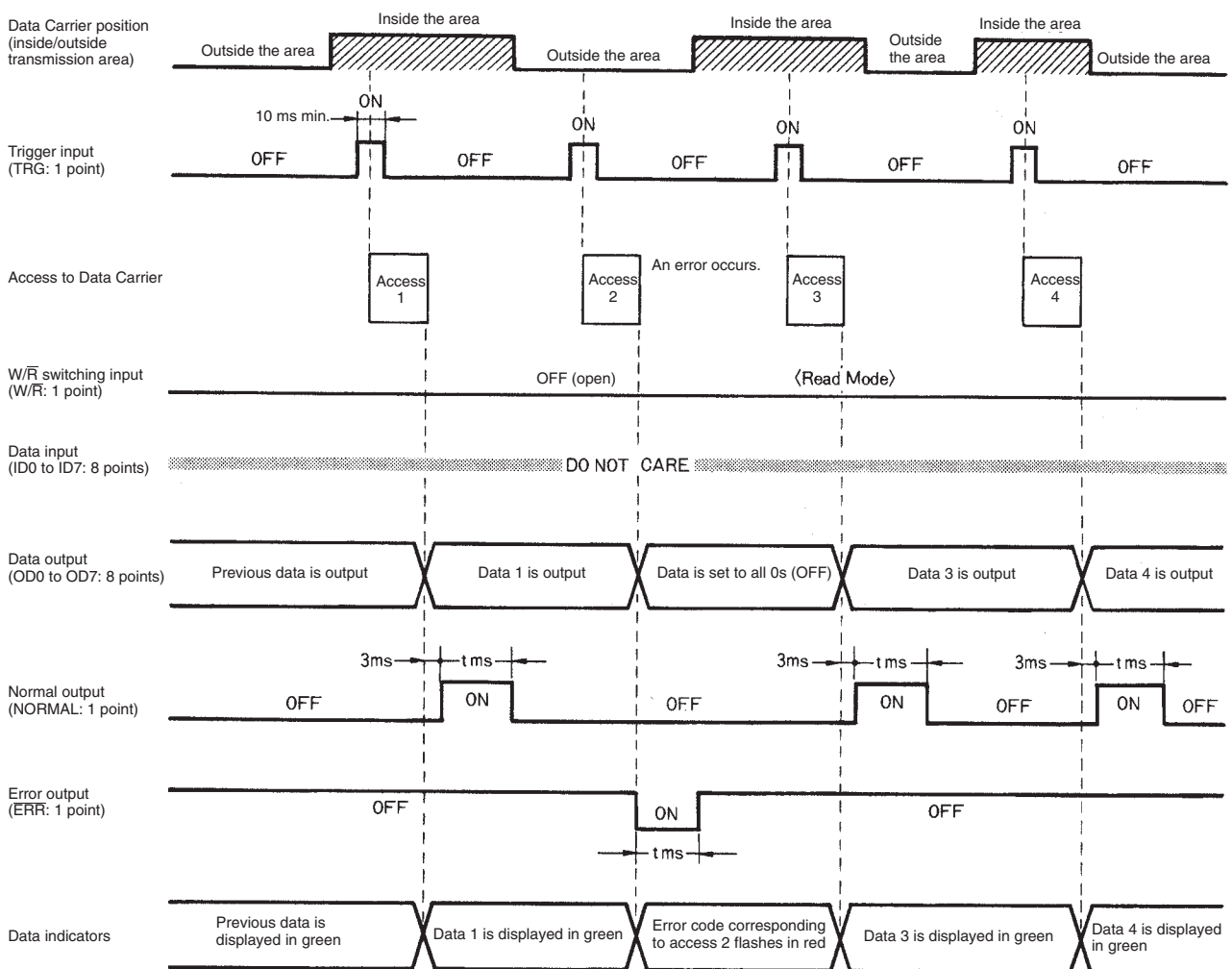

Normal Operation

1, 2, 3...

1. Turn the Amplifier on.
2. Switch the W/R switching input line to Read Mode (OFF: open).

Note At least 5 ms is required to fetch data after the W/R switching input line is switched to Read Mode.
3. Data in the eight data input lines (ID0 to ID7) is all ignored, so no data setting is required.
4. Turn the trigger input signal on when a Data Carrier is in the transmission area. (The trigger input signal must be turned on for at least 10 ms.)

5. When the trigger input signal is turned on, the Amplifier begins to access a Data Carrier and read data from it.
6. The Amplifier outputs read data to the eight data output lines (OD0 to OD7). The data indicators also light.
7. The normal output signal is turned on 3 ms after read data is output to the data output lines. It remains ON for the time (t ms) specified by the output time setting switch.
8. The data output lines remain in the same state until the next data is output.

When Errors Occur

Normally, an error occurs in SYNC mode if the trigger input signal is turned on when no Data Carrier is in the transmission area.

- 1, 2, 3...**
 1. If the trigger input signal remains ON when no Data Carrier is in the transmission area, this situation is treated as a "No Data Carrier" error.
 2. The error output signal remains ON for the time (t ms) specified by the output time setting switch. (The error output signal also serves as a RUN output signal when the signal level is low.)
 3. All the eight data output lines (OD0 to OD7) are simultaneously set to 0 (OFF). The error indicator lights in red. The data indicators flash an error code (corresponding to an error that occurred) in red. They stop flashing at the next access.

Instruction Before Use

- 1, 2, 3...**
 1. The trigger input signal (TRG) must remain ON for at least 10 ms.
 2. Read data must be fetched by turning ON the normal output signal (NORMAL).
If the output time setting switch is set to CONTINUOUS (infinite), the normal output signal or error output signal remains in the same state until the next trigger input signal is turned on.
 3. When switching the W/\bar{R} switching line, always wait at least 5 ms before starting the next processing.

VERIFY Read Mode

Timing Chart

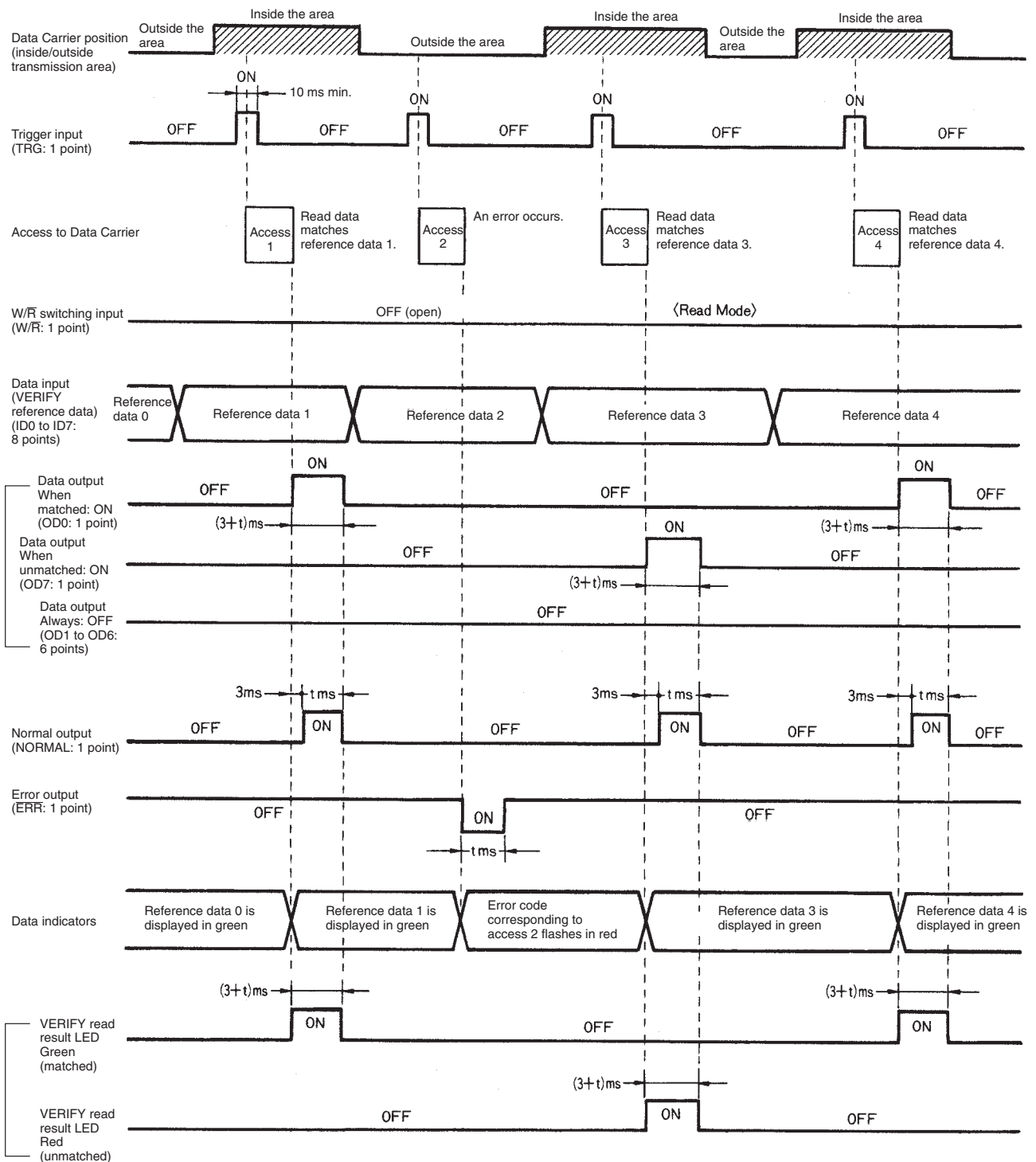

Normal Operation

- 1, 2, 3... 1. Turn the Amplifier on.
2. Switch the W/R switching input line to Read Mode (OFF: open).

Note At least 5 ms is required to fetch data after the W/R switching input line is switched to Read Mode.

- Enter VERIFY reference data into the eight data input lines (ID0 to ID7).
Example: When VERIFY reference data is AA_H

| | | | | | | | |
|-----------|------------|-----------|------------|-----------|------------|-----------|------------|
| ID7 | ID6 | ID5 | ID4 | ID3 | ID2 | ID1 | ID0 |
| 1 (ON) | 0 (OFF) | 1 (ON) | 0 (OFF) | 1 (ON) | 0 (OFF) | 1 (ON) | 0 (OFF) |

At this stage, the data indicators still indicate the previous reference data.

- Turn the trigger input signal on when a Data Carrier is in the transmission area. (The trigger input signal must remain ON for at least 10 ms.)
- When the trigger input signal is turned on, the Amplifier begins to access the Data Carrier and read data from it. When the Amplifier accesses the Data Carrier, the data indicators indicate the new reference data.
- The amplifier automatically compares the read data with the reference data. If the read data matches the reference data, data output line OD0 is turned on and the VERIFY read result LED lights in green (OK). If the read data does not match the reference data, data output line OD7 is turned on and the VERIFY read result LED lights in red (NG). In both cases above, data output lines OD1 to OD6 are always set to OFF.
- The normal output signal is turned on 3 ms after read data is output to the data output lines. It remains ON for the time (t ms) specified by the output time setting switch.

Note When the INHIBIT input signal is turned on, the normal output signal is unconditionally cleared even if it is within the specified time range. This also applies when the output time setting switch is set to CONTINUOUS (infinite).

- In VERIFY read mode, the data output lines are simultaneously turned OFF when the normal output signal is turned on. Also, if the INHIBIT input signal is turned on or an error occurs, all the data output lines are unconditionally set to 0 (OFF). All the data indicators are switched to 0 (OFF).

When Errors Occur

Normally, an error occurs in SYNC mode if the trigger input signal is turned on when no Data Carrier is in the transmission area.

- 1, 2, 3...
 - If the trigger input signal is turned on when no Data Carrier is in the transmission area, this situation is treated as a "No Data Carrier" error.
 - The error output signal remains ON for the time (t ms) specified by the output time setting switch. (The error output signal also serves as a RUN output signal when the signal level is low.)
 - When an error occurs, all the eight data output lines (OD0 to OD7) are simultaneously set to 0 (OFF). In VERIFY read mode, data output lines OD1 to OD6 are always set to 0 (OFF) regardless of error occurrence.
 - When an error occurs, the error indicator lights in red. The data indicators flash an error code in red. They stop flashing at the next access.

Instructions Before Use

- 1, 2, 3...
 - The trigger input signal (TRG) must remain ON for at least 10 ms.
 - The switching of the data input line must be done at least 10 ms before the Amplifier accesses a Data Carrier (i.e., more than 10 ms before the trigger input signal turns ON), and the data of input line will need to be fixed.
 - Output data must be fetched by turning ON the normal output signal (NORMAL).
If the output time setting switch is set to CONTINUOUS (infinite), the normal output signal or error output signal remains in the same state until the next trigger input signal is turned on.

- When switching the W/R switching line, always wait at least 5 ms before starting the next processing.

5-3-3 Write Operation in AUTO Mode

There are three write modes in AUTO mode: BYTE mode, BIT SET mode, and BIT CLR (clear) mode. In BYTE mode, 8-bit (1-byte) data is written. In BIT SET mode, only certain bits in eight bits are set to 1. In BIT CLR mode, only certain bits in eight bits are set to 0. Since the basic timing chart is the same for these modes, this section describes only the BYTE mode as a typical example.

Timing Chart (for BYTE Mode)

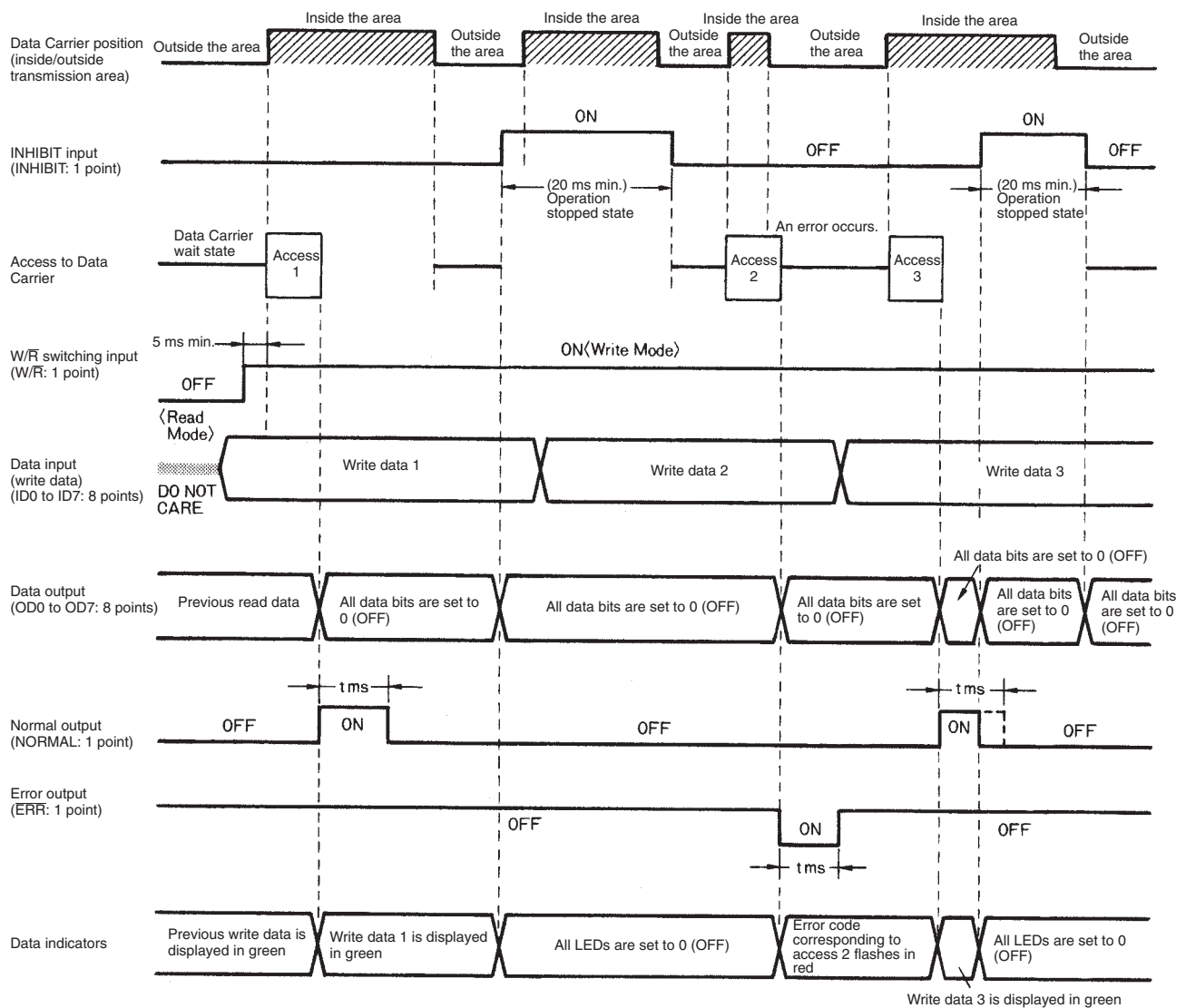

Normal Operation

- 1, 2, 3... 1. Switch the W/R switching input line from Read Mode (OFF: open) to write mode (ON).

Note At least 5 ms is required to fetch data after the W/R switching input line is switched to Read Mode.

2. Set the INHIBIT input line to OFF (open).
3. Enter write data into the eight data input lines (ID0 to ID7). At this stage, the data indicators still indicate the previous write data.

4. In AUTO mode, the Amplifier is already in a Data Carrier wait state. The Amplifier begins to access a Data Carrier and read data from it when the Data Carrier enters the transmission area.
5. When the Amplifier accesses the Data Carrier, the data indicators indicate the new write data. All the eight data output lines (OD0 to OD7) are set to 0 (OFF).
6. When write processing is complete, the normal output signal remains ON for the time (t ms) specified by the output time setting switch.

Note When the INHIBIT input signal is turned on, the normal output signal is unconditionally cleared even if it is within the specified time range. This also applies when the output time setting switch is set to CONTINUOUS (infinite). Also, when the INHIBIT input signal is turned on, the data output lines and data indicators are all set to 0 (OFF).

When Errors Occur

Normally, an error occurs in AUTO mode when the Data Carrier is traveling so fast that the Data Carrier moves out of the transmission area when the Amplifier is still accessing the Data Carrier.

- 1, 2, 3...**
1. When an error occurs, the error output signal remains ON for the time (t ms) specified by the output time setting switch. (The error output signal also serves as a RUN output signal when the signal level is low.)

Note When the INHIBIT input signal is turned on, the error output signal is unconditionally cleared even if it is still within the specified time range. This also applies when the output time setting switch is set to CONTINUOUS (infinite).

2. When an error occurs, all the eight data output lines (OD0 to OD7) are simultaneously set to 0 (OFF).
3. When an error occurs, the error indicator lights in red. The data indicators flash an error code in red. They stop flashing at the next access.

Instructions Before Use

- 1, 2, 3...**
1. When switching the W/\bar{R} switching line, always wait at least 5 ms before starting the next processing.
 2. The INHIBIT input signal must remain ON for at least 20 ms.
 3. To ensure data integrity, the data input lines must be switched at least 10 ms before the Amplifier accesses the Data Carrier.
 4. If the Data Carrier remains stopped within the transmission area in AUTO mode, the battery life will be extremely shortened. To prevent this, turn the INHIBIT input signal on to stop the Sensor from oscillating when the Data Carrier remains stopped within the transmission area after output data is fetched.

5-3-4 Write Operation in SYNC Mode

There are three write modes in SYNC mode: BYTE mode, BIT SET mode, and BIT CLR (clear) mode. Since the basic timing chart is the same for these modes, this section describes only the BYTE mode as a typical example.

Timing Chart

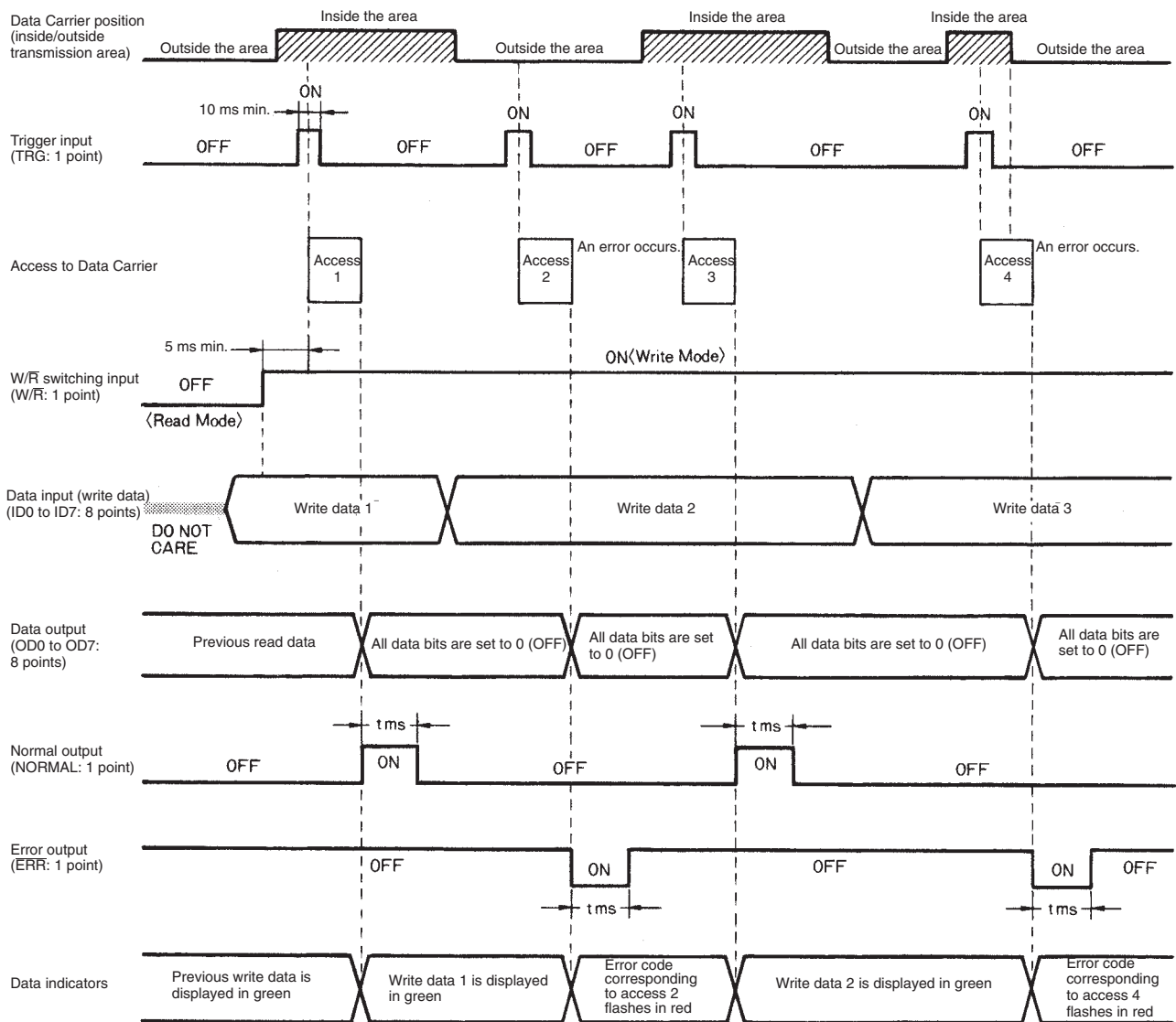

Normal Operation

- 1, 2, 3... 1. Switch the W/\bar{R} switching input line from Read Mode (OFF: open) to write mode (ON).

Note At least 5 ms is required to fetch data after the W/\bar{R} switching input line is switched to Read Mode.

2. Enter write data into the eight data input lines (ID0 to ID7). At this stage, the data indicators still indicate the previous write read data.
3. Turn the trigger input signal on when a Data Carrier is in the transmission area. (The trigger input signal must remain ON for at least 10 ms.)
4. When the trigger input signal is turned on, the Amplifier begins to access the Data Carrier and write data to it. When the Amplifier accesses the Data Carrier, the data indicators indicate the new write data. All the eight data output lines (OD0 to OD7) are set to 0 (OFF).
5. When write processing is complete, the normal output signal is turned on and remains ON for the time (t ms) specified by the output time setting switch.

When Errors Occur

Normally, an error occurs in SYNC mode if the trigger input signal is turned on when no Data Carrier is in the transmission area, or if the Data Carrier moves out of the transmission area when the Amplifier is still accessing the Data Carrier.

- 1, 2, 3...**
1. If the trigger input signal is turned on when no Data Carrier is in the transmission area, this situation is treated as a "No Data Carrier" error.
 2. The error output signal remains ON for the time (t ms) specified by the output time setting switch. (The error output signal also serves as a RUN output signal when the signal level is low.)

Note When the INHIBIT input signal is turned on, the error output signal is unconditionally cleared even if it is still within the specified time range. This also applies when the output time setting switch is set to CONTINUOUS (infinite).

3. When an error occurs, all the eight data output lines (OD0 to OD7) are simultaneously set to 0 (OFF).
4. When an error occurs, the error indicator lights in red. The data indicators flash an error code in red. They stop flashing at the next access.

Instructions Before Use

- 1, 2, 3...**
1. The trigger input signal (TRG) must remain ON for at least 10 ms.
 2. When switching the W/\bar{R} switching line, always wait at least 5 ms before starting the next processing.
 3. To ensure data integrity, the data input lines must be switched at least 10 ms before the Amplifier accesses the Data Carrier.
 4. If the output time setting switch is set to CONTINUOUS (infinite), the normal output signal or error output signal remains in the same state until the next trigger input signal is turned on.

5-4 V600-HAR92 Intelligent Flag II 16-bit Amplifier for Read Data Output

5-4-1 OUTPUT MODE 1: Standard Mode

There are two read modes in OUTPUT MODE 1 (standard mode): AUTO and SYNC modes. The Intelligent Flag II Amplifier differs from the Intelligent Flag Amplifier with regard to the items below, and these must be written into the communications program for the host.

Features of Intelligent Flag II FA ID Systems

Output OFF-delay Time Setting

When the Data Carrier moves out of the transmission area, the output OFF-delay timer starts. After the timer expires, the data output, normal output, error output, and parity-check output lines are all set to 0 (OFF).

Error Code Output

When an error occurs, the error code corresponding to the error is output to the data output lines (OD0 to OD15).

Parity-Check Output

Vertical parity is checked for data that is output to data output lines OD0 to OD15. For example, when the number of data bits that are set to 1 (ON) is even, the parity-check output line is turned OFF; when the number is odd, the parity-check output line is turned on.

Read Operation in AUTO Mode

Timing Chart

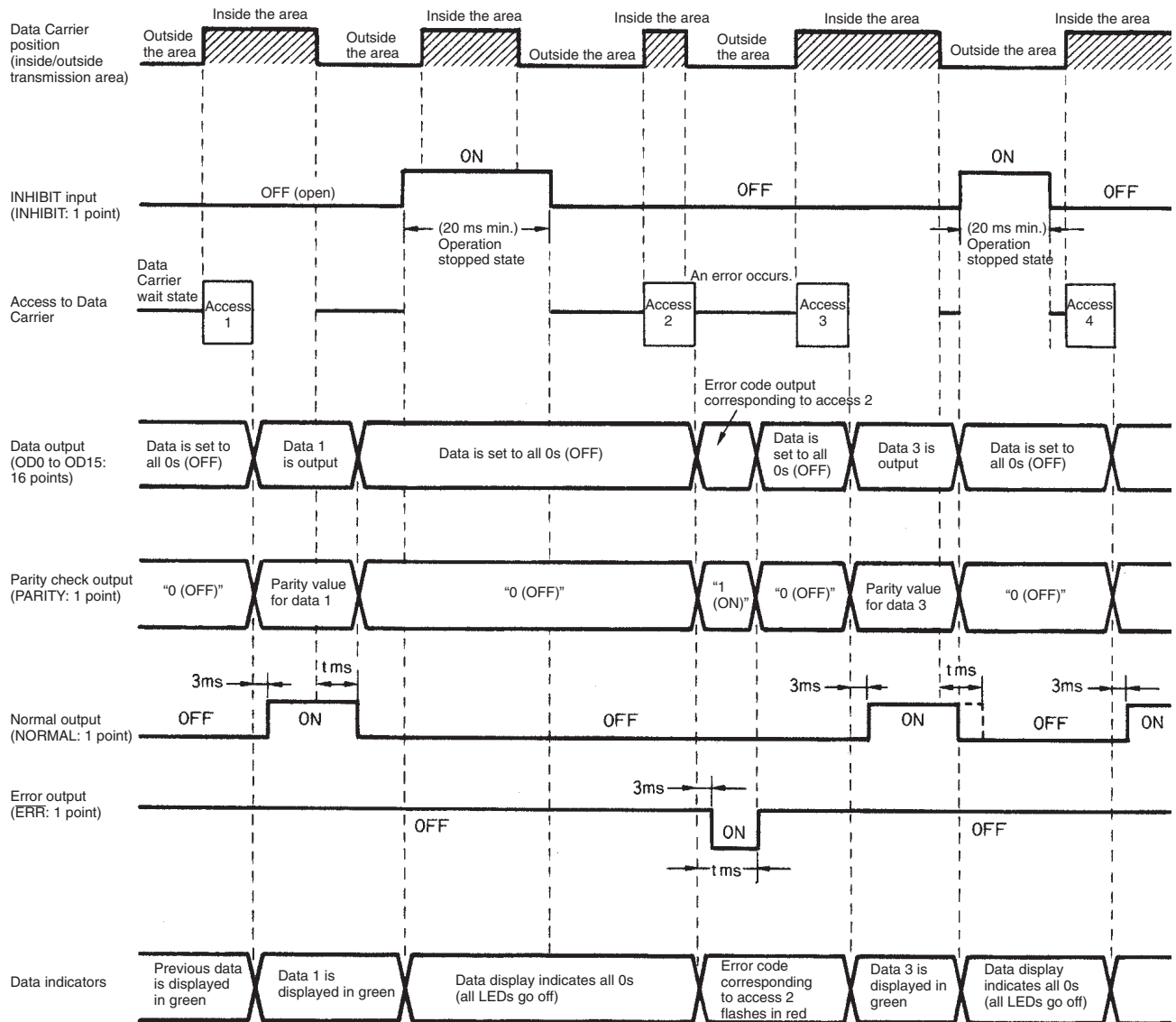

Normal Operation

- 1, 2, 3... 1. When power is turned on, the Amplifier waits for a Data Carrier. All 16 data output lines (OD0 to OD15) are initially set to 0 (OFF).
2. The Amplifier begins to access a Data Carrier and read data from it when a Data Carrier enters the transmission area.
3. The Amplifier outputs read data to the 16 data output lines (OD0 to OD15). The data indicators also light.
4. When data is output, the vertical parity value for the data output lines is output to the parity-check output line (PARITY). For example, when the number of data bits that are set to 1 (ON) is even, the parity-check output line is set to 0 (OFF); when the number is odd, the parity-check output line is set to 1 (ON).
5. The normal output signal is turned ON 3 ms after read data is output to the data output lines.
6. The data output lines, parity-check output line, and normal output line remain in the same state while the Data Carrier stays within the transmission area.

7. When the Data Carrier moves out of the transmission area, the output OFF-delay timer starts. After the time (t ms) specified by the output OFF-delay time setting switch, the data output, parity-check output, and normal output lines are all set to 0 (OFF).

Note a) When the INHIBIT input signal is turned ON, all the data output, parity-check output, and normal output lines are unconditionally set to 0 (OFF) even if the Data Carrier stays within the transmission area or the output OFF-delay timer is still active.

b) If the Data Carrier enters the transmission area again while the output OFF-delay timer is active, each output line is cleared and enters an output state corresponding to the next access to the Data Carrier.

8. The data indicators remain in the same state until the Amplifier begins to access the next Data Carrier. However, these LEDs are unconditionally turned OFF when the INHIBIT input signal is turned ON.

When Errors Occur

Normally, an error occurs in AUTO mode when the Data Carrier is traveling so fast that the Data Carrier moves out of the transmission area when the Amplifier is still accessing the Data Carrier.

- 1, 2, 3...
 1. When an error occurs, the error code corresponding to the error is output to the data output lines.
 2. When the error code is output, the data indicators flash the error code in red.
 3. Since only the error code output line is set to ON, the parity-check output line is set to 1 (ON).
 4. The error output line is set to ON 3 ms after data is output to the data output lines and parity check output line. The error output line remains ON for the output OFF-delay time (t ms) after the Data Carrier move out of the transmission area. If, however, the Data Carrier moves out of the transmission area while the Amplifier is accessing the Data Carrier, the error output line remains ON for the output OFF-delay time (t ms) after the Amplifier accesses the Data Carrier. (The error output signal also serves as a RUN output signal when the signal level is low.)
 5. After the output OFF-delay time (t ms), all the data output, parity-check output, and error output lines are set to 0 (OFF).

Note When the INHIBIT input signal is turned ON, each output line is unconditionally set to 0 (OFF) even if the output OFF-delay timer is still active.

6. The data indicators remain in the same state until the Amplifier begins to access the next Data Carrier. However, these LEDs are unconditionally turned OFF when the INHIBIT input signal is turned ON.

Instructions Before Use

- 1, 2, 3...
 1. The INHIBIT input signal must remain ON for at least 20 ms.
 2. Output data must be fetched by turning ON the normal output signal (NORMAL).
 3. If the Data Carrier remains stopped within the transmission area in AUTO mode, the battery life will be extremely shortened. To prevent this, turn the INHIBIT input signal ON to stop the Sensor from oscillating when the Data Carrier remains stopped within the transmission area after output data is fetched.

Read Operation in SYNC Mode

Timing Chart

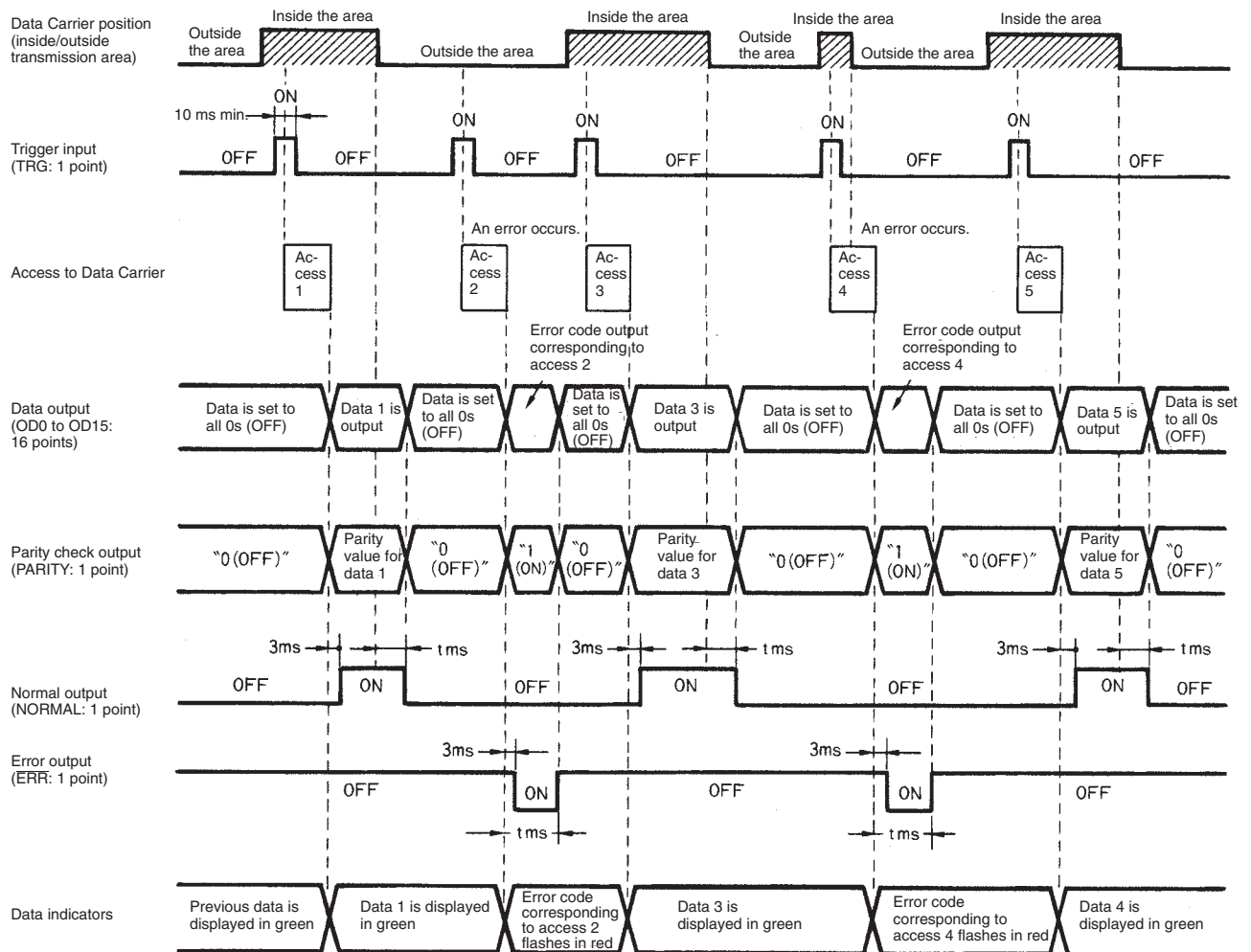

Normal Operation

- 1, 2, 3... 1. Turn on the Amplifier.
2. Turn ON the trigger input signal when a Data Carrier is in the transmission area. (This signal must remain ON for at least 10 ms.)
3. When the trigger input signal is turned ON, the Amplifier begins to access a Data Carrier and read data from it.
4. The Amplifier outputs read data to the 16 data output lines (OD0 to OD15). The data indicators also light.
5. When data is output, the vertical parity value for the data output lines is output to the parity-check output line (PARITY).
6. The normal output signal is turned ON 3 ms after read data is output to the data output lines.
7. The data output lines, parity-check output line, and normal output line remain in the same state while the Data Carrier stays within the transmission area.
8. When the Data Carrier moves out of the transmission area, the output OFF-delay timer starts. After the time (t ms) specified by the output OFF-delay time setting switch, the data output, parity-check output, and normal output lines are all set to 0 (OFF).

Note If the Data Carrier enters the transmission area again while the output OFF-delay timer is active, each output line is cleared and enters an output state corresponding to the next access to the Data Carrier.

9. The data indicators remain in the same state until the Amplifier begins to access the next Data Carrier.

When Errors Occur

Normally, an error occurs in SYNC mode if the trigger input signal is turned ON when no Data Carrier is in the transmission area, or if the Data Carrier moves out of the transmission area when the Amplifier is still accessing the Data Carrier.

- 1, 2, 3...
 1. If the trigger input signal is turned ON when no Data Carrier is in the transmission area, this situation is treated as a "No Data Carrier" error.
 2. The error code corresponding to the error is output to the data output lines. When the error code is output, the data indicators flash the error code in red.
 3. The parity-check output line is simultaneously turned ON. (Since only the error code output line is set to ON, the parity-check output line is set to 1 (ON).)
 4. The error output line is set to ON 3 ms after data is output to the data output lines and parity check output line. The error output line remains ON for the output OFF-delay time (t ms) after the Data Carrier move out of the transmission area. If, however, the Data Carrier moves out of the transmission area while the Amplifier is accessing the Data Carrier, the error output line remains ON for the output OFF-delay time (t ms) after the Amplifier accesses the Data Carrier. (The error output signal also serves as a RUN output signal when the signal level is low.)
 5. After the output OFF-delay time (t ms), all the data output, parity-check output, and error output lines are set to 0 (OFF).

Note When the next trigger input signal is turned ON, each output line is unconditionally set to 0 (OFF) even if the output OFF-delay timer is still active.

6. The data indicators remain in the same state until the Amplifier begins to access the next Data Carrier. However, these LEDs are unconditionally turned OFF when the trigger input signal is turned ON.

Instructions Before Use

- 1, 2, 3...
 1. The trigger input signal (TRG) must remain ON for at least 10 ms.
 2. Output data must be fetched by turning ON the normal output signal (NORMAL).
 3. If the Data Carrier remains stopped within the transmission area, the battery life will be extremely shortened. To prevent this, do not use the Amplifier for applications that cause the Data Carrier to remain stopped in the transmission area.

5-4-2 OUTPUT MODE 2: Wiring Saving Mode

There are two read modes in OUTPUT MODE 2 (wiring saving mode): AUTO and SYNC modes. One of the features of OUTPUT MODE 2 is that the Intelligent Flag II Amplifier can communicate with the host by using only the 16 data output lines (OD0 to OD15).

If 14 bits are enough to transmit information, one strobe output line (STRB), one error output line (ERR), and 14 data output lines can be used for communications control instead of using all 16 data output lines.

As shown in the timing charts on the following pages, the input and output lines other than the 16 data output lines are also always active, so the most appropriate combination of these input and output lines can be specified in the wiring and host communication program for your applications.

Read Operation in AUTO Mode

Timing Chart

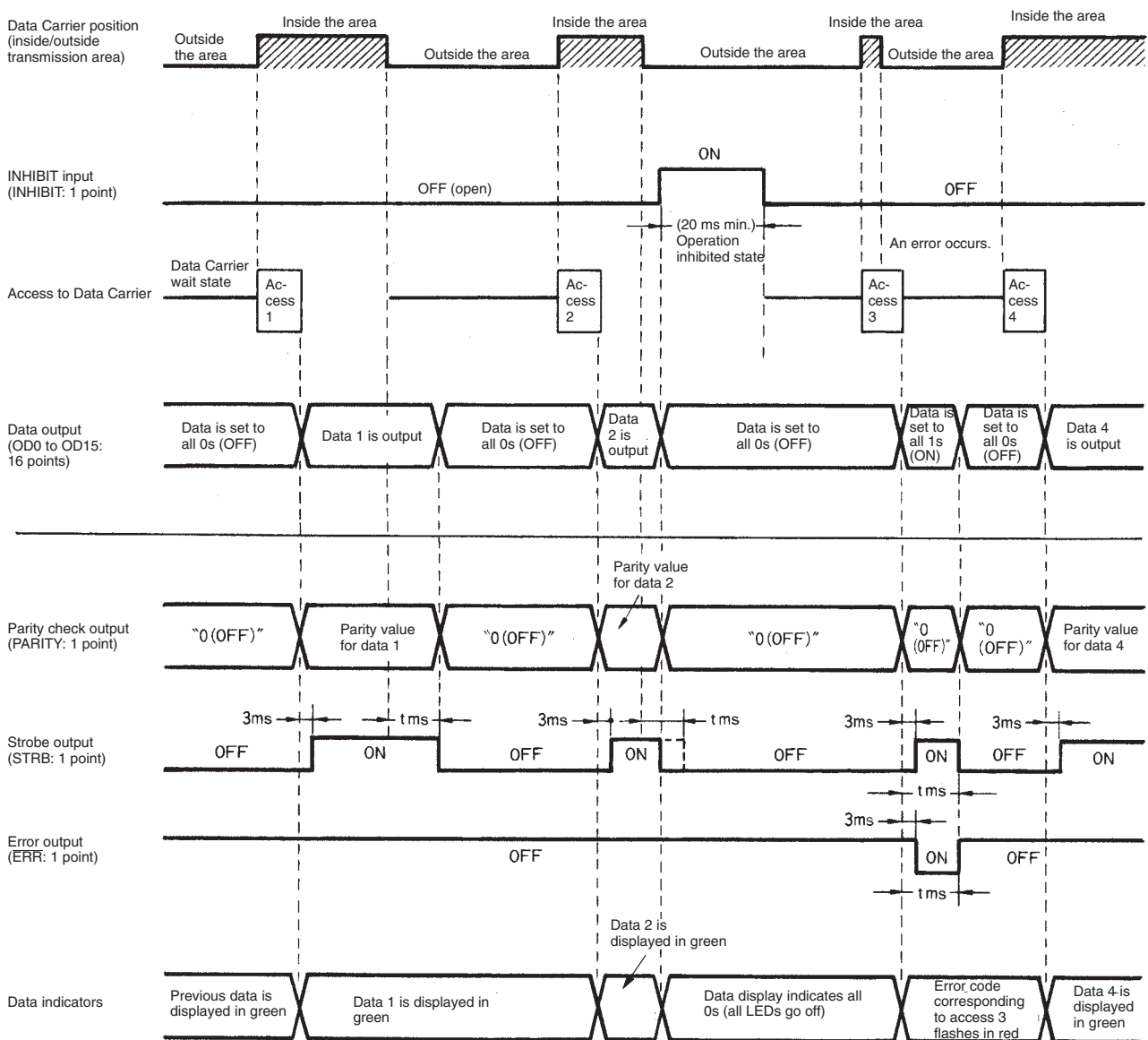

Normal Operation

- 1, 2, 3... 1. When power is turned on, the Amplifier waits for a Data Carrier. All 16 data output lines (OD0 to OD15) are initially set to 0 (OFF).
2. When a Data Carrier enters the transmission area, the Amplifier begins to access the Data Carrier and read data from it.
3. Read data is output to the 16 data output lines (OD0 to OD15). The data indicators light.
4. When the Data Carrier moves out of the transmission area, the output OFF-delay timer starts. After the time (t ms) specified by the output OFF-delay time setting switch, all the data output lines are set to 0 (OFF).

Note a) When the INHIBIT input signal is turned ON, all the data output lines are set to 0 (OFF) even if the Data Carrier stays within the transmission area or the output OFF-delay timer is still active.

- b) If the Data Carrier enters the transmission area again while the output OFF-delay timer is active, each data output line is set to 0 (OFF) and enters an output state corresponding to the next access to the Data Carrier.
- 5. The data indicators remain in the same state until the Amplifier begins to access the next Data Carrier. However, these LEDs are unconditionally turned OFF when the INHIBIT input signal is turned ON.
- 6. The parity-check output line (PARITY) is simultaneously turned ON when the data output lines are turned ON.
- 7. The strobe output line (STRB) is turned ON 3 ms after data is output to the data output lines. It is automatically turned OFF by the output OFF-delay timer t ms after the Data Carrier moves out of the transmission area.

Note As in the data output lines, the parity-check output and strobe output lines are also cleared when the INHIBIT input signal is turned ON.

When Errors Occur

Normally, an error occurs in AUTO mode when the Data Carrier is traveling so fast that the Data Carrier moves out of the transmission area when the Amplifier is still accessing the Data Carrier.

- 1, 2, 3...
 - 1. When an error occurs, all the data output lines are set to 1 (ON).
 - 2. When all the data output lines are set to ON, the data indicators flash the error code in red. The data indicators remain in the same state until the Amplifier begins to access the next Data Carrier. However, these LEDs are unconditionally turned OFF when the INHIBIT input signal is turned ON.
 - 3. When the Data Carrier moves out of the transmission area, the output OFF-delay timer starts. After the time (t ms) specified by the output OFF-delay time setting switch, all the data output lines are set to 0 (OFF). However, if the Data Carrier moves out of the transmission area when the Amplifier is accessing the Data Carrier, all the data output lines are set to 0 (OFF) t ms after the access is complete.
 - 4. The parity-check output line (PARITY) is simultaneously turned ON when data is output. Since all the data output lines are set to ON (1) when an error occurs, the parity-check output line is set to 0 (OFF).
 - 5. The strobe output line (STRB) and error output line ($\overline{\text{ERR}}$) are turned ON 3 ms after data is output to the data output lines. They are turned OFF t ms (specified in the output OFF-delay timer) after the Data Carrier moves out of the transmission area. (The error output signal also serves as a RUN output signal when the signal level is low.) However, if the Data Carrier moves out of the transmission area when the Amplifier is accessing the Data Carrier, these output lines are set to 0 (OFF) t ms after the access is complete.

Note When the INHIBIT input signal is turned ON, each output line is unconditionally set to 0 (OFF) even if the output OFF-delay timer is still active.

Instructions Before Use

- 1, 2, 3...
 - 1. When communications are controlled with all 16 data output lines (OD0 to OD15), "all 1s (ON)" and "all 0s (OFF)" cannot be used as data.
 - 2. In OUTPUT MODE 2 (wiring saving mode), no error code can be output when an error occurs. (When an error occurs, all the data output lines are set to 1 (ON).) However, the data indicators flash the error code in red corresponding to the error.
 - 3. When the strobe output line (STRB) is used, output data must be fetched by turning ON the strobe output line.
 - 4. If communications are controlled using only the data output lines (without use of the strobe output line), output data must be fetched when all the data output lines are set to 0 (OFF) or 1 (ON). To do so, for example, include a

timer setting in the program to monitor the state of each data output line at regular intervals.

5. If the Data Carrier remains stopped within the transmission area in AUTO mode, the battery life will be extremely shortened. To prevent this, turn ON the INHIBIT input signal to stop the Sensor from oscillating when the Data Carrier remains stopped within the transmission area after output data is fetched.

Read Operation in SYNC Mode

Timing Chart

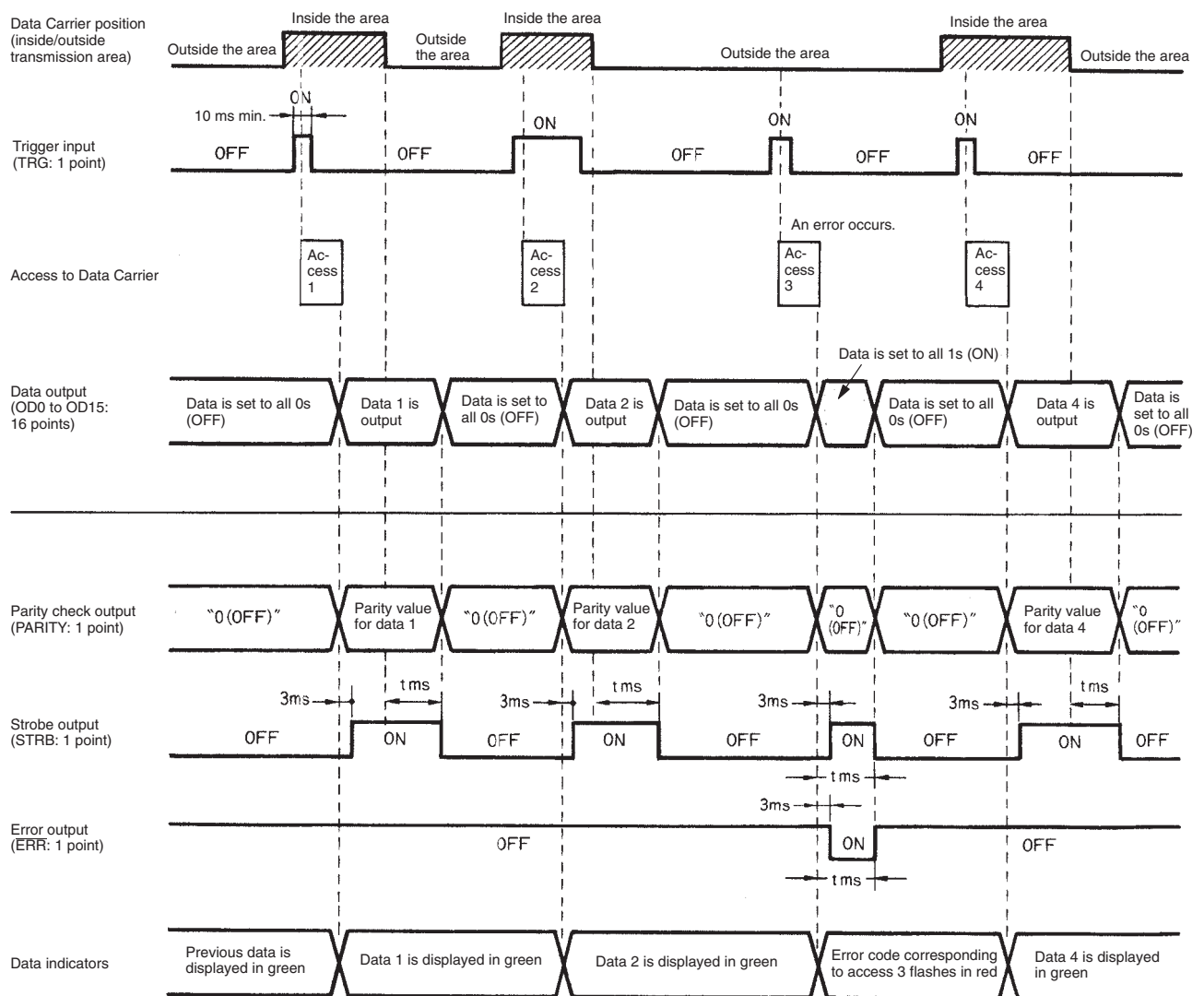

Normal Operation

- 1, 2, 3... 1. Turn on the Amplifier. All 16 data output lines (OD0 to OD15) are initially set to 0 (OFF).
2. Turn ON the trigger input signal when a Data Carrier is in the transmission area. (The trigger input signal must remain ON for at least 10 ms.)
3. When the trigger input signal is turned ON, the Amplifier begins to access the Data Carrier and read data from it.
4. Read data is output to the 16 data output lines (OD0 to OD15). The data indicators light.

5. When the Data Carrier moves out of the transmission area, the output OFF-delay timer starts. After the time (t ms) specified by the output OFF-delay time setting switch, all the data output lines are set to 0 (OFF).

Note If the trigger input signal is turned ON again while the output OFF-delay timer is active, all the data output lines are set to 0 (OFF) and enters an output state corresponding to the next access to the Data Carrier.

6. The data indicators remain in the same state until the Amplifier begins to access the next Data Carrier.
7. The parity-check output line (PARITY) is simultaneously turned ON when the data output lines are turned ON. It is also turned OFF when the data output lines are turned OFF.
8. The strobe output line (STRB) is turned ON 3 ms after data is output to the data output lines. It is automatically turned OFF by the output OFF-delay timer t ms after Data Carrier moves out of the transmission area.

When Errors Occur

Normally, an error occurs in SYNC mode if the trigger input signal is turned ON when no Data Carrier is in the transmission area, or if the Data Carrier moves out of the transmission area when the Amplifier is still accessing the Data Carrier.

- 1, 2, 3...
 1. If the trigger input signal is turned ON when no Data Carrier is in the transmission area, this situation is treated as a "No Data Carrier" error.
 2. When all the data output lines are set to 1 (ON), the data indicators flash the error code corresponding to the error in red. The data indicators remain in the same state until the Amplifier begins to access the next Data Carrier.
 3. When an error occurs, the output OFF-delay timer starts, then, t ms later, all the data output lines are set to 0 (OFF).
 4. The parity-check output line (PARITY) is simultaneously turned ON when data is output. Since all the data output lines are set to ON (1) when an error occurs, the parity-check output line is set to 0 (OFF).
 5. The strobe output and error output lines are turned ON 3 ms after data is output to the data output lines. As in the data output lines, the strobe output and error output lines are set to OFF (0) t ms after an error occurs. (The error output signal also serves as a RUN output signal when the signal level is low.)

Note When the next trigger input signal is turned ON, each output line is unconditionally set to 0 (OFF) even if the output OFF-delay timer is still active.

Instructions Before Use

- 1, 2, 3...
 1. The trigger input signal (TRG) must remain ON for at least 10 ms.
 2. When communications are controlled with all 16 data output lines (OD0 to OD15), "all 1s (ON)" and "all 0s (OFF)" cannot be used as data.
 3. In OUTPUT MODE 2 (wiring-saving mode), no error code can be output when an error occurs. (When an error occurs, all the data output lines are set to 1 (ON).) However, the data indicators flash the error code in red corresponding to the error.
 4. When the strobe output line (STRB) is used, output data must be fetched by turning ON the strobe output line.
 5. If communications are controlled using only the data output lines (without use of the strobe output line), output data must be fetched when all the data output lines are set to 0 (OFF) or 1 (ON). To do so, for example, include a timer (that starts when the trigger input signal is turned ON) in the program to monitor the state of each data output line at regular intervals.

6. If the Data Carrier remains stopped within the transmission area, the battery life will be extremely shortened. To prevent this, do not use the Amplifier for applications that cause the Data Carrier to remain stopped in the transmission area.

5-5 Sample Programming for Host

Sample Programming 1

The following sample programming reads data from the Data Carrier through external switches such as sensors and turns ON the output bit corresponding to each model.

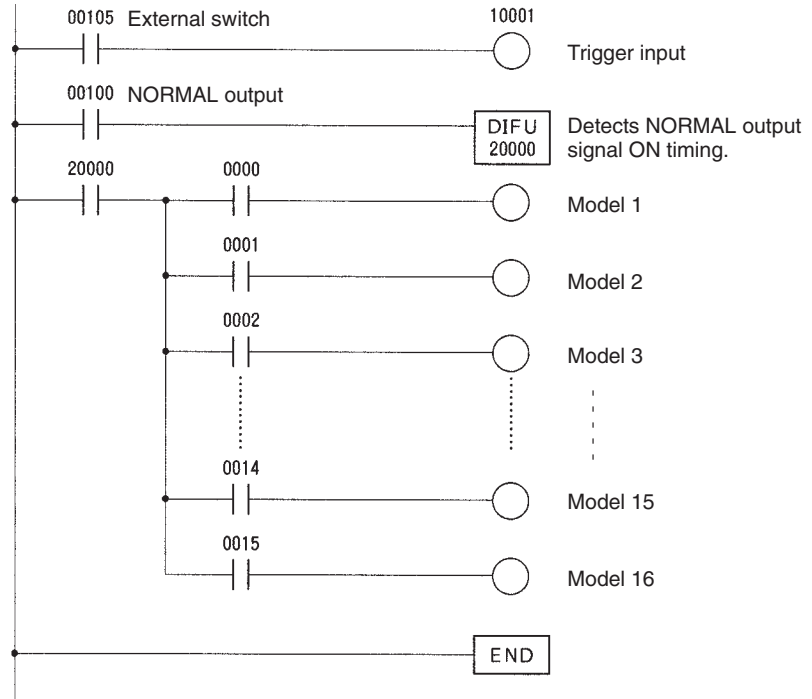

Sample Programming 2 The following sample programming uses a parity-check output line to check for disconnection.

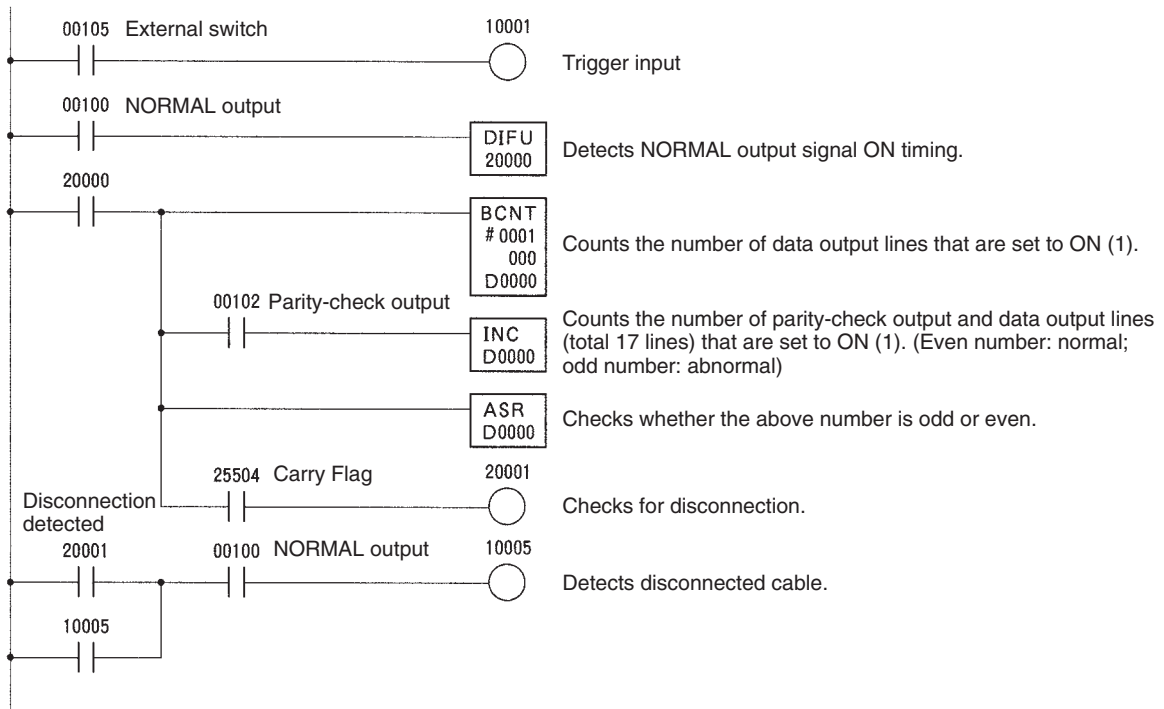

Sample Programming 3

The following sample programming uses OUTPUT MODE 2 (wiring saving mode). In AUTO mode, 16-bit data is read from the Data Carrier and transferred to DM 00001, and the normal termination bit (02101) is turned ON. If a communications error occurs, the abnormal termination bit(02100) is turned ON.

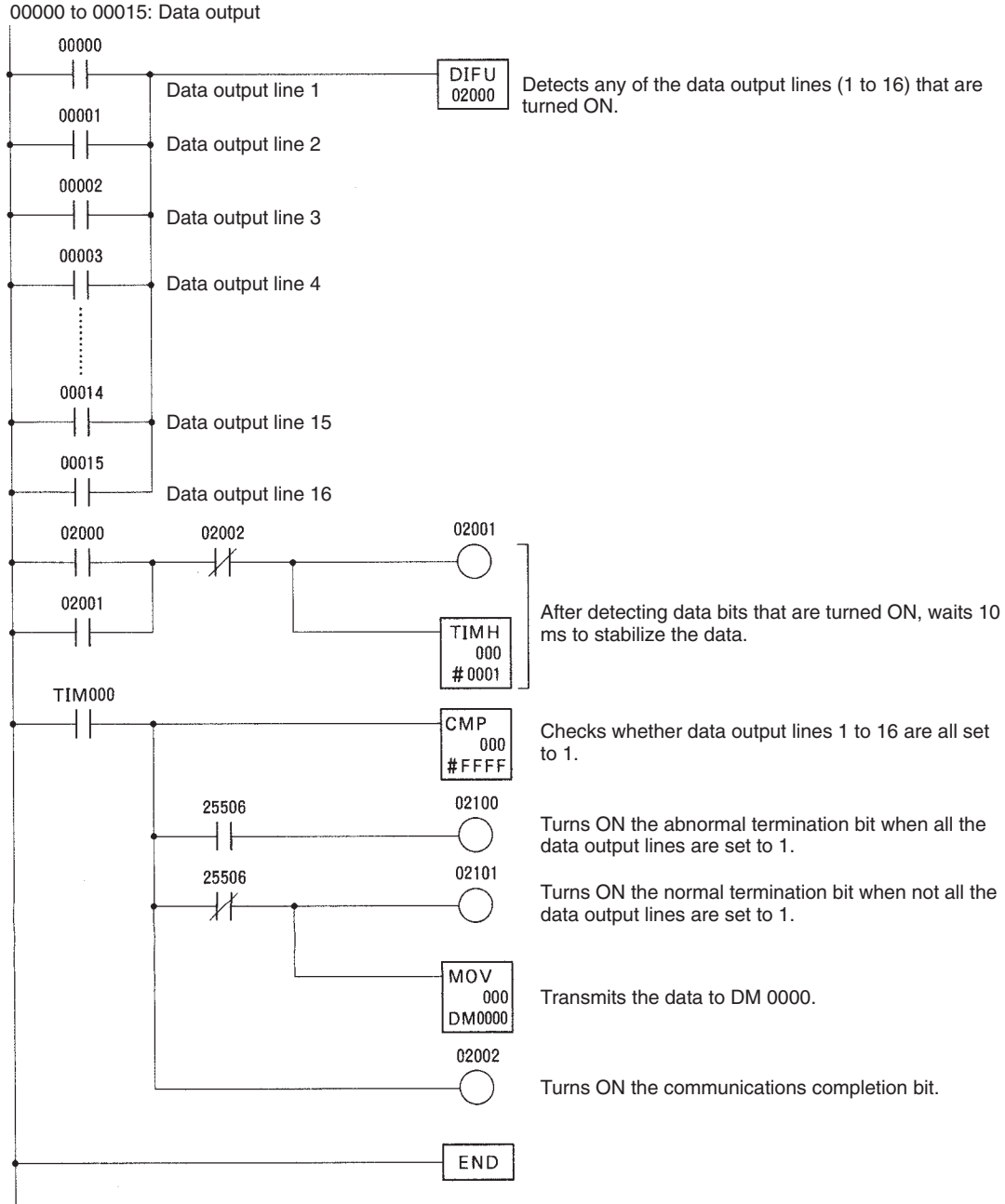

SECTION 6

Chemical Resistance

This section provides information on the chemical resistance of Sensors and Data Carriers.

| | | |
|-----|---|-----|
| 6-1 | V600-HS51, V600-HS61, and V600-HS63 Sensors | 112 |
| 6-2 | Data Carriers | 113 |

6-1 V600-HS51, V600-HS61, and V600-HS63 Sensors

ABS resin is used as casing material and epoxy resin is used as filler resin. Avoid using chemicals that may affect ABS resin and epoxy resin by referring to the tables below.

The Sensor is not explosion-proof.

Note The information on chemical resistance presented in this section must be used for reference purposes only. The change rates of Sensor characteristics vary with temperatures and chemical concentrations. Therefore, before using the Sensors in an actual production environment, always conduct tests to check for any problems.

Chemicals that Cause Deformation, Cracks, etc.

| ABS resin | Epoxy resin |
|--|---|
| Trichlene, acetone, xylene, toluene, gasoline, creosol, methylene chloride, phenol, cyclohexane, aqua regia, chromic acid, sulfuric acid (90% RT), methyl ethyl ketone, aniline, nitrobenzine, monochlorobenzine, pyridine, nitric acid (60% RT), formic acid (80% RT) | Aqua regia, chromic acid, sulfuric acid (90% RT), nitric acid (60% RT), ammonia solution, acetone, methylene chloride, phenol |

Chemicals that may Cause Discoloration, Swelling, etc.

| ABS resin | Epoxy resin |
|---|---|
| Hydrochloric acid, alcohol, Freon, sodium hydroxide, hydrogen peroxide, benzine, sulfuric acid (10% RT), nitric acid (10% RT), phosphoric acid (85% RT), ammonia solution | Sulfuric acid (10% RT), nitric acid (10% RT), hydrochloric acid (30% RT), acetic acid (50% RT), calcium hydroxide, benzine, creosol, alcohol, cyclohexane, toluene, xylene, benzine, grease |

Chemicals that Do Not Affect ABS Resin or Epoxy Resin

| ABS resin | Epoxy resin |
|--|---|
| Ammonia, kerosine, mineral oil, developer, Yushiroken S50, Chemi-Cool Z, Velocity No. 3, Yushiroken EEE-30Y, petroleum, grease acetate, calcium hydroxide, phosphoric acid (30% RT), hydrochloric acid (10% RT), potassium hydroxide | Ammonia, hydrochloric acid (10% RT), potassium hydroxide, petroleum, gasoline, Yushiroken S50, Chemi-Cool Z, Velocity No. 3, Yushiroken EEE-30Y |

Note Tests for these chemicals were conducted at room temperature (23°C). Chemicals that do not affect ABS or epoxy resin at room temperature (23°C) may affect them at higher or lower temperatures. Therefore, carefully examine the effects of these chemicals on ABS and epoxy resin beforehand.

6-2 Data Carriers

Note The information on chemical resistance and extracted substances presented in this section must be used for reference purposes only. The change rates of Data Carrier characteristics and the amounts of substances extracted vary with temperatures and chemical concentrations. Therefore, before using the Data Carrier in an actual production environment, always conduct tests to check for any problems.

V600-D23P61, V600-D23P53, and V600-D23P54 EEPROM Data Carriers

V600-D8KR12D, V600-D8KR13, and V600-D8KR04 SRAM Data Carriers

ABS resin is used as casing material and epoxy resin is used as filler resin. Avoid using chemicals that may affect ABS resin and epoxy resin by referring to the following tables.

Chemicals that Cause Deformation, Cracks, etc.

| ABS resin | Epoxy resin |
|--|---|
| Trichlene, acetone, xylene, toluene, gasoline, creosol, methylene chloride, phenol, cyclohexane, aqua regia, chromic acid, sulfuric acid (90% RT), methyl ethyl ketone, aniline, nitrobenzine, monochlorobenzine, pyridine, nitric acid (60% RT), formic acid (80% RT) | Aqua regia, chromic acid, sulfuric acid (90% RT), nitric acid (60% RT), ammonia solution, acetone, methylene chloride, phenol |

Chemicals that may Cause Discoloration, Swelling, etc.

| ABS resin | Epoxy resin |
|---|---|
| Hydrochloric acid, alcohol, Freon, sodium hydroxide, hydrogen peroxide, benzine, sulfuric acid (10% RT), nitric acid (10% RT), phosphoric acid (85% RT), ammonia solution | Sulfuric acid (10% RT), nitric acid (10% RT), hydrochloric acid (30% RT), acetic acid (50% RT), calcium hydroxide, benzine, creosol, alcohol, cyclohexane, toluene, xylene, benzine, grease |

Chemicals that Do Not Affect ABS Resin or Epoxy Resin

| ABS resin | Epoxy resin |
|--|---|
| Ammonia, kerosine, mineral oil, developer, Yushiroken S50, Chemi-Cool Z, Velocity No. 3, Yushiroken EEE-30Y, petroleum, grease acetate, calcium hydroxide, phosphoric acid (30% RT), hydrochloric acid (10% RT), potassium hydroxide | Ammonia, hydrochloric acid (10% RT), potassium hydroxide, petroleum, gasoline, Yushiroken S50, Chemi-Cool Z, Velocity No. 3, Yushiroken EEE-30Y |

Note Tests for these chemicals were conducted at room temperature 23°C. The chemicals that do not affect ABS or epoxy resin at room temperature 23°C may affect them at higher or lower temperatures. Therefore, carefully examine the effects of these chemicals on ABS and epoxy resin beforehand.



Caution The V600-D23P71/P72 Data Carriers have no chemical and oil resistance. Do not use them in places exposed to spattering from chemicals and oil.

V600-D23P66 and V600-A86 Data Carriers

PPS resin is used as material. Avoid using chemicals that may affect PPS resin by referring to the tables below.

| Chemical name | | Room temperature | 90° |
|----------------------------|-----|------------------|-----|
| Hydrochloric acid | 37% | A | A |
| | 10% | A | A |
| Sulfuric acid | 98% | A | B |
| | 50% | A | A |
| | 30% | A | A |
| | 3% | A | A |
| Nitric acid | 60% | B | C |
| | 40% | A | B |
| | 10% | A | A |
| Hydrogen fluoride solution | 40% | A | A |
| Chromic acid | 40% | A | A |
| Hydrogen peroxide solution | 28% | A | B |
| | 3% | A | A |
| Sodium hydroxide solution | 60% | A | A |
| | 10% | A | A |
| | 1% | A | A |
| Ammonia solution | 28% | A | B |
| | 10% | A | B |
| Sodium chloride | 10% | A | A |
| Sodium carbonate | 20% | A | A |
| | 2% | A | A |
| Sodium hypochlorite | | A | A |
| Phenol solution | 5% | A | A |
| Glacial acetic acid | | A | A |
| Acetic acid | | A | A |
| Oleic acid | | A | A |
| Methyl alcohol | 95% | A | A |
| Ethyl alcohol | 95% | A | A |
| Ethyl acetate | | A | A |
| Sebacic acid diethylhexyl | | A | A |
| Acetone | | A | A |
| Diethyl ether | | A | A |
| n-heptane | | A | A |
| 2-2-4 trimethylpentane | | A | A |
| Benzine | | A | A |
| Toluene | | A | A |
| Aniline | | A | A |
| Mineral oil | | A | A |
| Gasoline | | A | A |
| Insulating oil | | A | A |
| Dichloroethylene | | A | A |
| Carbon tetrachloride | | A | A |

A: Has no adverse effect, B: May cause discoloration, swelling, etc.,

C: Causes deformation, cracks, etc.

Note The above tables show the extent of changes in PPS resin that is exposed to each chemical at room temperature and at 90°C. If the Data Carrier is to be exposed to different chemicals, concentrations, and temperatures from those shown in the tables, always conduct tests before using the Data Carrier in such an environment.

V600-D23P66SP Data Carriers

PFA is used as the exterior of the V600-D23P66SP Data Carrier. Before using the V600-D23P66SP, study the characteristics of PFA by reading the following reference:

Chemical Resistance of Fluoroplastic PFA (Reference)**PFA: Tetrafluorethylene-Perfluoroalkylvinylether copolymer**

Fluoroplastic PFA does not react with most chemicals except molten alkali metal, hot pressurized fluorine (F₂), and some halogen derivatives. The following tables show the results of tests in which PFA was soaked in or exposed to commonly used organic and inorganic chemicals. In these tests, a compression-molded test piece (1.3 mm thick) was soaked in the chemical at a specified temperature for a week (168 hours) and taken out of the chemical, then the weight change, tensile strength, and elongation of the test piece were immediately measured. If the change in the tensile strength is 15% or less, the change in the elongation is 10% or less, and the increase in the weight is less than 0.5%, the results of the test can be considered normal.

If PFA is exposed to trichloroacetic acid, tri-n-butyl phosphate, perchloroethylene, carbon tetrachloride, and other liquids (which easily make resin surfaces wet) at a high temperature, it tends to increase its weight due to absorption and reduce its tensile strength. Even when PFA absorbs chemicals and solvents, its molecular structure will not change. If, however, PFA is subject to temperature or pressure changes or mechanical damage when it has absorbed chemicals, the chemicals will repeatedly expand and contract inside PFA, causing mechanical problems such as cracks and bulging. In fact, this problem occurs with any kind of plastic.

Inorganic Chemicals

| Chemicals | Test temperature (°C) | Resulting characteristics (%) | | Weight increase rate (%) |
|----------------------------------|-----------------------|-------------------------------|------------|--------------------------|
| | | Tensile strength | Elongation | |
| Concentrated hydrochloric acid | 120 | 98 | 100 | 0.0 |
| Concentrated sulfuric acid | 120 | 95 | 98 | 0.0 |
| Hydrofluoric acid (60%) | 23 | 99 | 99 | 0.0 |
| Fuming sulfuric acid | 23 | 95 | 96 | 0.0 |
| Aqua regia | 120 | 99 | 100 | 0.0 |
| Chromic acid (50%) | 120 | 93 | 97 | 0.0 |
| Concentrated nitric acid | 120 | 95 | 98 | 0.0 |
| Fuming nitric acid | 23 | 99 | 99 | 0.0 |
| Concentrated ammonia solution | 66 | 98 | 100 | 0.0 |
| Caustic soda (50%) | 120 | 93 | 99 | 0.4 |
| Hydrogen peroxide solution (30%) | 23 | 93 | 95 | 0.0 |
| Bromine | 23 | 99 | 100 | 0.5 |
| Chlorine | 120 | 92 | 100 | 0.5 |
| Ferrous chloride (25%) | 100 | 93 | 98 | 0.0 |
| Zinc chloride (25%) | 100 | 96 | 100 | 0.0 |
| Sulfuryl chloride | 69 | 83 | 100 | 2.7 |
| Chlorosulfonic acid | 151 | 91 | 100 | 0.0 |
| Concentrated phosphoric acid | 100 | 93 | 100 | 0.0 |

Organic Chemicals

| Chemicals | Test temperature (°C) | Resulting characteristics (%) | | Weight increase rate (%) |
|-----------------------|-----------------------|-------------------------------|------------|--------------------------|
| | | Tensile strength | Elongation | |
| Glacial acetic acid | 118 | 95 | 100 | 0.4 |
| Acetic anhydride | 139 | 91 | 99 | 0.3 |
| Trichloroacetic acid | 196 | 90 | 100 | 2.2 |
| Isooctane | 99 | 94 | 100 | 0.7 |
| Naphtha | 100 | 91 | 100 | 0.5 |
| Mineral oil | 180 | 87 | 95 | 0.0 |
| Toluene | 110 | 88 | 100 | 0.7 |
| o-cresol | 191 | 92 | 96 | 0.2 |
| Nitrobenzine | 210 | 90 | 100 | 0.7 |
| Benzyl alcohol | 205 | 93 | 99 | 0.3 |
| Aniline | 185 | 94 | 100 | 0.3 |
| n-butylamine | 78 | 86 | 97 | 0.4 |
| Ethylenediamine | 117 | 96 | 100 | 0.1 |
| Tetrahydrofuran | 66 | 88 | 100 | 0.7 |
| Benzaldehyde | 179 | 90 | 99 | 0.5 |
| Cyclohexane | 156 | 92 | 100 | 0.4 |
| Methyl ethyl ketone | 80 | 90 | 100 | 0.4 |
| Acetophenone | 202 | 90 | 100 | 0.6 |
| Dimethylphthalate | 200 | 98 | 100 | 0.3 |
| n-butyl acetate | 125 | 93 | 100 | 0.5 |
| Tri-n-butyl phosphate | 200 | 91 | 100 | 2.0 |
| Methylene chloride | 40 | 94 | 100 | 0.8 |
| Perchloroethylene | 121 | 86 | 100 | 2.0 |
| Carbon tetrachloride | 77 | 87 | 100 | 2.3 |
| Dimethyl formamide | 154 | 96 | 100 | 0.2 |
| Dimethyl sulfoxide | 189 | 95 | 100 | 0.1 |
| Dioxane | 101 | 92 | 100 | 0.6 |

Reference: *Fluoroplastics Handbook*, The Nikkan Kogyo Shimbun Ltd. (Takaomi Satogawa)

Substances Extracted from Data Carrier (Reference)

If chemicals penetrate into the built-in Data Carrier through PFA, ions may be extracted from the Data Carrier.

- **Results of Ion-exchange Chromatography**

The built-in Data Carrier was soaked in hot water (100°C for 16 hours), and extracted ions were analyzed. The results are shown below.

- **Extracted Ions (Concentration)**

Cl⁻ 0.5 p.p.m. Na⁺ 10 p.p.m.
NH₄⁺ . . 11 p.p.m. K⁺ 1.0 p.p.m.





- **Results of ICP Emission Spectral Analysis**

The V600-D23P66SP Data Carrier was soaked in concentrated hydrochloric acid (which can easily penetrate through PFA) at 80°C for 300 hours, then extracted substances were analyzed.

- **Extracted Substances (Concentration)**

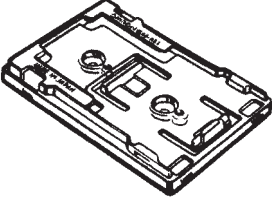
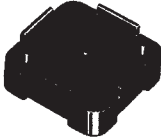
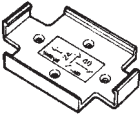
Si 700 ng/ml S 1000 ng/ml
Ca 30 ng/ml

Appendix Optional Accessories

| Parts name | Specifications | Model | Remarks |
|---|--|-----------------|---|
| <p>Data Carrier Holder</p>  | <p>For V600-D23P71 or V600-D23P72 Data Carriers</p> | <p>V600-A84</p> | <p>When the Holder is to be mounted on a plastic packet or container, it can be secured using either screws or an ultrasonic welding.</p> <p>Multiple Holders can be stacked to serve as a spacer to separate the Data Carrier from the mounting surface.</p> |
| <p>Data Carrier Attachment</p>  | <p>For V600-D23P66 Data Carriers</p> | <p>V600-A86</p> | <p>—</p> |
| <p>Data Carrier Holder</p>  | <p>For V600-D2KR16 Data Carriers</p>  | <p>V600-A81</p> | <p>Secure with at least two M3 flat head screws.</p> |
| <p>Lithium Battery (CR2016)</p>  | <p>For V600-D2KR16 Data Carriers</p>  | <p>V600-A82</p> | <p>This battery is available on the market.</p> <p>Type: CR2016</p> <p>A battery replacement cover seal is provided.</p> |

Index

A–C

accessories, 117
Amplifier
 component names and functions, 8
 specifications, 8, 26, 27
Attachment, Data Carrier. *See* Data Carrier Attachment
Battery, 117
battery life, 50
connector pin assignments, 28, 30, 32
connectors, interface connector, 29, 31

D

Data Carrier
 chemical resistance, 113
 installation, 71
 EEPROM, 71
 SRAM, 80
 specifications
 EEPROM Data Carrier, 39
 SRAM Data Carrier, 45
 travel speed, 57
Data Carrier Attachment, 41, 117
Data Carrier Holder, 40, 47, 117
dimensions, 34, 38
DIN Track, 61

E–G

EEPROM Data Carrier, specifications, 39
error codes, 10, 15, 22
features, 2
 function list, 26
grounding, 62

H–I

Holder, Data Carrier. *See* Data Carrier Holder
hosts, 83
 sample programming, 108
I/O circuit diagram, 28, 29, 31
I/O specifications, 28
indicators, data indicators, 10, 14, 21
installation
 Amplifier, 60
 clearance, 61
 environment, 60
 methods, 60

Data Carrier, 71
 Sensor, 64
 methods, 64
Interface Cables, 27, 37
 connection to Amplifier, 63
interface connector, 28, 29, 31
interference
 between Proximity Sensor and Sensor, 70
 between Sensors, 68

L–M

Lithium Battery, 117
load short-circuiting, 33
memory map, 43, 48
models, 3
modes
 AUTO mode, 11
 DATA read mode, 15
 parity check output, 23
 read, 22
 SYNC mode, 11
 VERIFY read mode, 15
 write
 BIT CLR mode, 16
 BIT SET mode, 16
 BYTE mode, 16

O–P

operation
 16-bit Amplifier for read data output, 99
 8-bit Amplifier for read data output, 84
 8-bit Amplifier with versatile functions, 88
 AUTO mode, 84, 88, 96
 communications with host, 83
 OUTPUT MODE 1, 99
 OUTPUT MODE 2, 103
 overview, 6
 SYNC mode, 86, 92, 97
performance, 7
power supply voltage, 33
precaution, installation environment, 63
precautions, 33
programming, sample for hosts, 108

S

Sensor

- chemical resistance, 112
- connection to Amplifier, 64
- dimensions, 38
- effects of surrounding metal, 66
- interference, 68, 70
- specifications, 37

specifications, 7

- Amplifier, 8, 26
- EEPROM Data Carrier, 39
- I/O, 28
- Sensor, 37
- SRAM Data Carrier, 45

SRAM Data Carrier, specifications, 45

switches

- access mode setting, 9, 13, 19
- address setting, 8, 12, 18
- output mode setting, 21
- output OFF–delay time setting, 20
- output time setting, 10, 14
- read mode setting, 14
- write mode setting, 14

switching current, 33

system configuration

- examples, 23
- Intelligent Flag, 4
- Intelligent Flag II, 5

T–W

timing chart

- AUTO mode, 85, 96
 - DATA read mode, 88
 - VERIFY read mode, 90
- OUTPUT MODE 1
 - AUTO mode, 100
 - SYNC mode, 102
- OUTPUT MODE 2
 - AUTO mode, 104
 - SYNC mode, 106
- SYNC mode, 87, 98
 - DATA read mode, 92
 - VERIFY read mode, 94

transmission

- range, 55
- specifications, 53
 - distance, 54
 - time, 56

transmission distance, 54

- effects of inclination, 74, 76, 77, 78, 79, 81, 82
- effects of metal, 72, 74, 76, 78, 79

water resistance, Amplifier, 62

write protection, 44, 49

Revision History

A manual revision code appears as a suffix to the catalog number on the front cover of the manual.

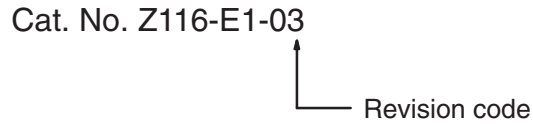

The following table outlines the changes made to the manual during each revision. Page numbers refer to the previous version.

| Revision code | Date | Revised content |
|---------------|---------------|---|
| 1 | April 1997 | Original production |
| 02 | December 2003 | Information pertaining to model V600–HAR81 added throughout manual. Information pertaining to model V600–HAM81 added throughout manual. Page 26 : Output specifications for models V600–HAR81 and V600–HAM81 added to the table. Page 28 : I/O circuit diagram for model V600–HAR81 added. Page 29 : I/O circuit diagram for model V600–HAM81 added. Page 33 : Information pertaining to model V600–HA□81 added to precautions and warnings. |
| 02A | April 2004 | Page v : Replaced page and added information following it. |
| 03 | June 2020 | Changes due to the end of production of V600-D8KR12 Tag |

OMRON Corporation Industrial Automation Company
Kyoto, JAPAN

Contact: www.ia.omron.com

Regional Headquarters

OMRON EUROPE B.V.

Wegalaan 67-69, 2132 JD Hoofddorp
The Netherlands
Tel: (31)2356-81-300/Fax: (31)2356-81-388

OMRON ASIA PACIFIC PTE. LTD.

No. 438A Alexandra Road # 05-05/08 (Lobby 2),
Alexandra Technopark,
Singapore 119967
Tel: (65) 6835-3011/Fax: (65) 6835-2711

OMRON ELECTRONICS LLC

2895 Greenspoint Parkway, Suite 200
Hoffman Estates, IL 60169 U.S.A.
Tel: (1) 847-843-7900/Fax: (1) 847-843-7787

OMRON (CHINA) CO., LTD.

Room 2211, Bank of China Tower,
200 Yin Cheng Zhong Road,
PuDong New Area, Shanghai, 200120, China
Tel: (86) 21-5037-2222/Fax: (86) 21-5037-2200

Authorized Distributor:

© OMRON Corporation 1997-2020 All Rights Reserved.
In the interest of product improvement,
specifications are subject to change without notice.

Cat. No. **Z116-E1-03**

0620(0497)

Cat. No. Z116-E1-03

V600-series ID System: Intelligent Flag and Intelligent Flag II OPERATION MANUAL

OMRON