

DC Electronic Circuit Protector

S8V-CP



Adjustable rated output current per branch circuit, ranging from 2 to 10 A

Load branching and reliable protection with space-saving



Process

Panels

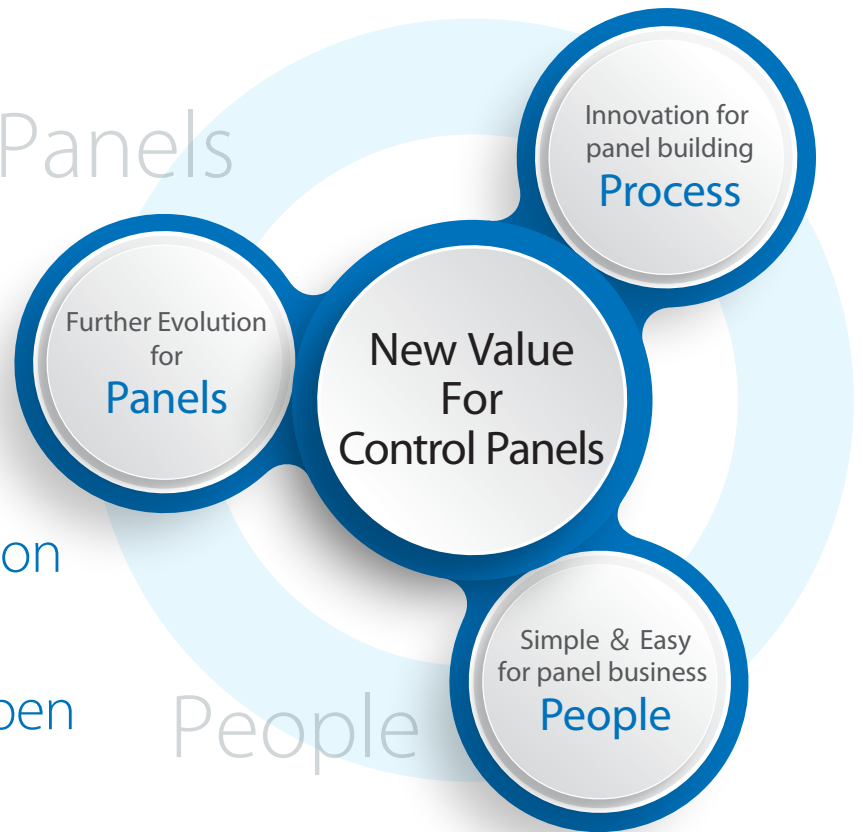

Achievement for secure DC line protection when short circuit or over current state happen on DC 24 V line.

In accordance with the accelerating demand to the high power rating of the power supplies due to increased DC devices, you must meet a growing need for the safety design of each branch circuit and reliable protection to a circuit where abnormality occurs.

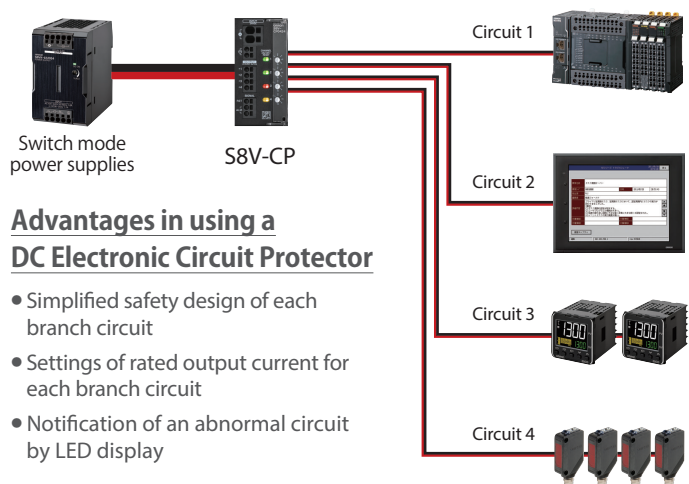

Advantages in using a DC Electronic Circuit Protector

- Simplified safety design of each branch circuit
- Settings of rated output current for each branch circuit
- Notification of an abnormal circuit by LED display



Value Design for Panel

Our shared Value Design for Panel (herein after referred to as "Value Design") concept for the specifications of products used in control panels will create new value to our customer's control panels. Combining multiple products that share the Value Design concept will further increase the value provided to control panels.

Protecting up to eight branch circuits in the 42-mm low profile design

Constant monitoring of the current realizes tripping characteristic with less variations and errors.

Easy wiring with the Push-In Plus Terminal Blocks

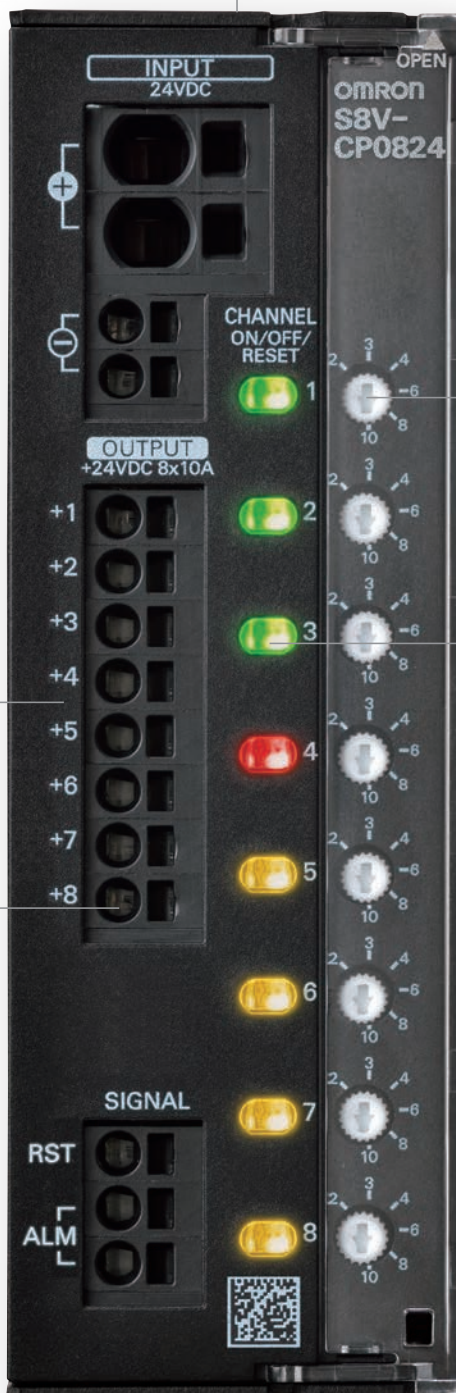

Free from new parts arrangements or conversions for sudden design change of devices. One fits various current range



Setting the rated output current available for 2 A, 3 A, 4 A, 6 A, 8 A, and 10 A.



* Also available is UL Class 2 compatible type with the fixed 3.8 A.

Push button with indicator

Just press the button to toggle ON/OFF for each branch circuit



3-step LED indication for easy indication of the status of each branch circuit

-  Green lit : Output ON
-  Yellow lit : Over current
-  Yellow blinking or red blinking : output tripping / alarm output

DC Electronic Circuit Protector S8V-CP

4ch S8V-CP0424

4ch S8V-CP0424S (UL Class 2 with a fixed rated output current 3.8 A)

8ch S8V-CP0824

Photo : S8V-CP0824

Facing any challenge in performing safety design of electric circuit?

Design

- Branch design and the design for securing the safety are complicated.
- Small diameter cables are preferable for easy wiring.

Selection

- The selection is difficult as the tripping characteristics of thermomagnetic circuit protectors may widely vary by the temperature and unit variations.

Assembly

- More branch circuits need more spaces.

Start-up and Maintenance

- If an abnormality occurred, the power supply activates its protection function to stop the all circuits prior to the tripping function activation of the thermomagnetic circuit protectors.

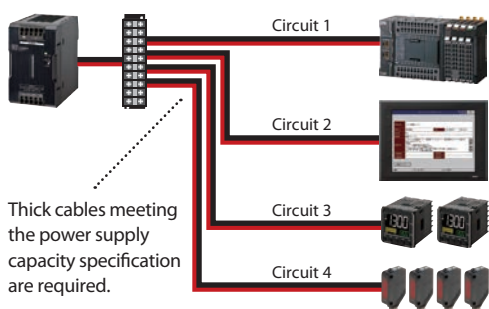

S8V-CP allows you to :

Design easily

Simplify design of branches and safety securing with the one unit.



e.g. : AWG10

e.g. : AWG14

Design with load-dependent cables

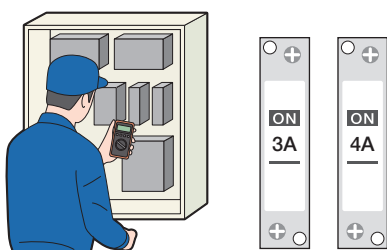

S8V-CP allows you to :

Reliable protection

The tripping characteristic of DC electronic circuit protector securely helps the defective circuit to cut off with less variation errors as designed.

DC Electronic Circuit Protector (S8V-CP0424, S8V-CP0824)

rated output current — 3A

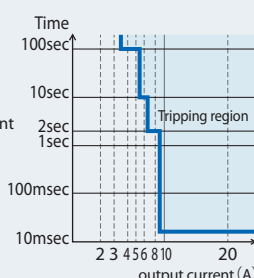

*At the setting in 3 A of rated output current

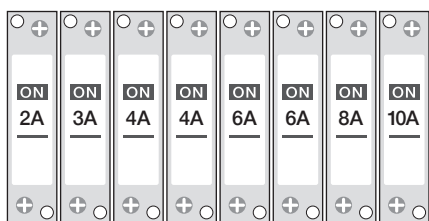

140mm

e.g. : 8 branch circuits

S8V-CP allows you to :

Space-saving design

DC electronic circuit protector with low profile design reduces the spaces for installation.



8 branch circuits

42mm

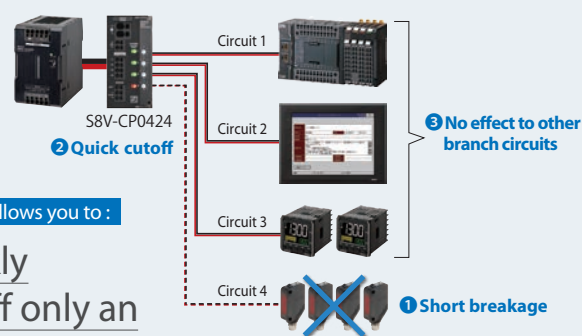
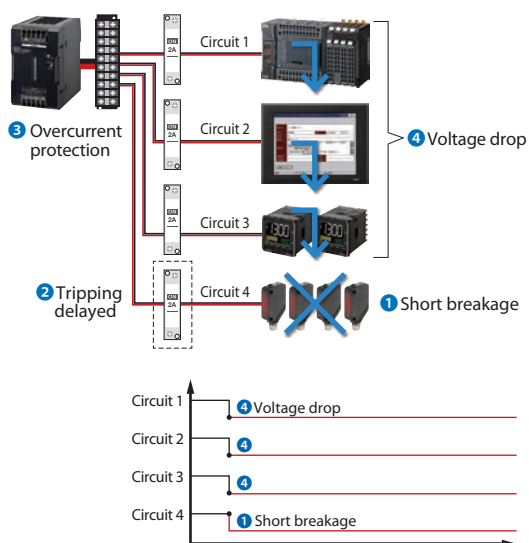

S8V-CP allows you to :

Quickly cut off only an abnormal circuit

Easy to identify the troubled parts

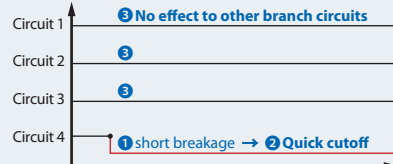

Replacement of the thermomagnetic circuit protector is easy

With maintaining the characteristics of the thermomagnetic circuit protector, make the variation errors less.

An example of the operating characteristics of the thermomagnetic circuit protector

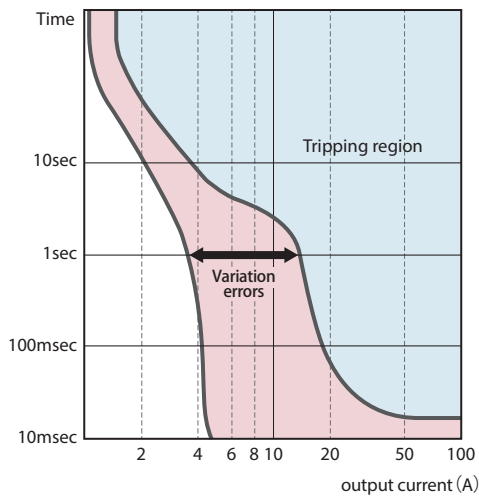

The operating characteristics of DC Electronic Circuit Protector (S8V-CP0424, S8V-CP0824)

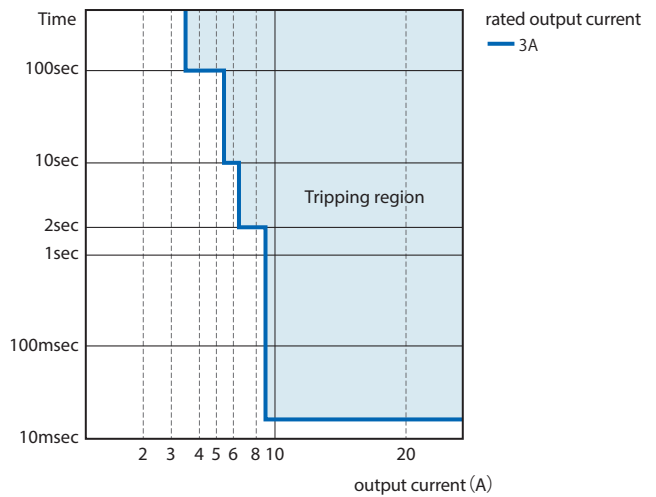

*At the setting in 3 A of rated output current

An alarm signal output enables to output an abnormal occurrence to an upstream controller.

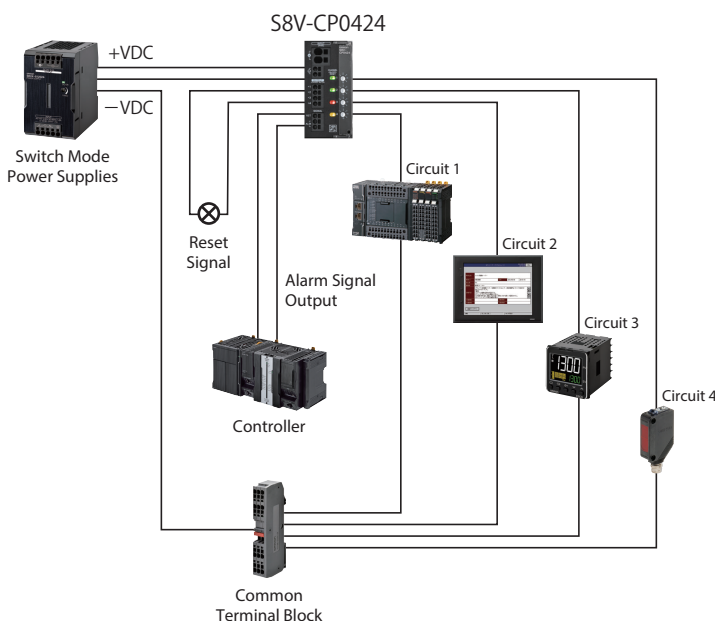

Sequential start-up of branch circuits minimizes start-up troubles by the inrush current.

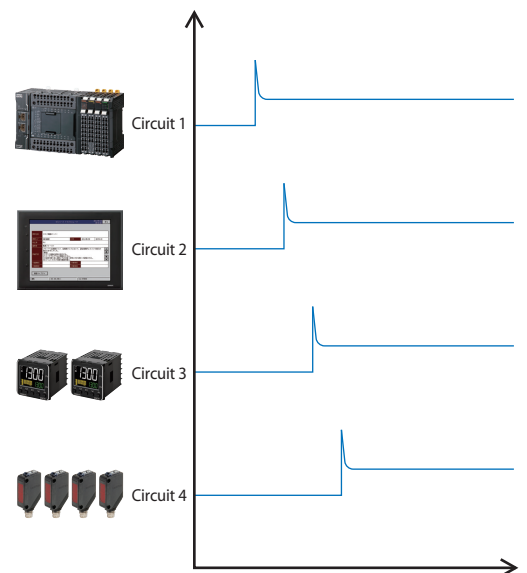

Lineup



Model	Number of Outputs	Rated Input Voltage	Rated Output Current
S8V-CP0424	4ch	24V	2A, 3 A, 4A, 6A, 8A, 10A
S8V-CP0424S	4ch (ULClass2)		3.8A
S8V-CP0824	8ch		2A, 3 A, 4A, 6A, 8A, 10A



New Value for Control Panels

OMRON will help integrate both of designs and wirings with peripheral devices, such as noise filters, power supplies.

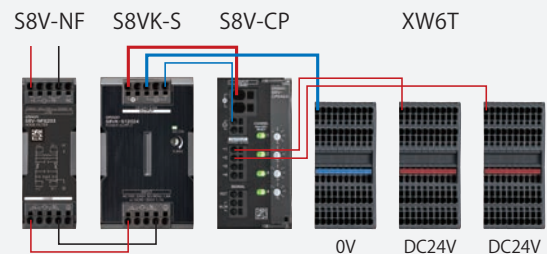

- By adding devices in the newly available space, you can mount more devices in the same size of control panel to increase control panel functionality
- We'll help you downsize control panels by reducing the width between wiring ducts and dead space.

Related Products



S8VK-S
A small body for more compact control panels



S8VK-WA
Three-phase 200V Power Supplies. Easy for balanced design



S8VK-X
IoT Support for control panels, Compatible with EIP, Power Supplies with the indicator.



S8V-NF
Easy setting, Noise filter



XW6T
Common terminal blocks with visible indicators



The processes and costs for the UL certificate can be reduced.

UL Class2 [S8V-CP0424S]

What is the UL Class 2 output?

It is the classification that indicates “power supplies and the related products with safety outputs of which voltage, current, and power are limited to a certain level, so that not to cause an electric shock or fire,” and is evaluated by UL1310.

For the UL Class 2 output, the voltage, current, and power are provided as follows:

- DC30 V or lower of output voltage
- 8 A or lower of output current
- 100 VA or lower of output power

Any loads and parts to be connected to this UL Class 2 output can be used without UL certificate.

What is S8V-CP0424S (UL Class 2 output type)?

To meet the conditions of this UL Class 2 output, the rated output current is fixed at 3.8 A.

- 24 V of output voltage
→ meets DC30 V or lower
- 3.8 A of output current
→ meets 8 A or lower
- 24 V * 3.8 A of output power = 91.2 VA
→ meets 100 VA or lower

The processes and costs for applying to a safety standard for the devices can be reduced.

As S8V-CP0424S has already certified the UL Class 2 output, the UL evaluation of the circuit to be connected to this output may not be needed, which can help reduce processes and costs for the UL certificate. Any loads and parts to be connected to this UL Class 2 output can be used without UL certificate. Furthermore, that also helps for cost down and easy selection of the parts, because any wiring materials without UL certificate are usable in the control panel.

OMRON Corporation Industrial Automation Company
Kyoto, JAPAN

Contact: www.ia.omron.com

Regional Headquarters

OMRON EUROPE B.V.
Wegalaan 67-69, 2132 JD Hoofddorp
The Netherlands
Tel: (31)2356-81-300/Fax: (31)2356-81-388

OMRON ASIA PACIFIC PTE. LTD.
No. 438A Alexandra Road # 05-05/08 (Lobby 2),
Alexandra Technopark,
Singapore 119967
Tel: (65) 6835-3011/Fax: (65) 6835-2711

OMRON ELECTRONICS LLC
2895 Greenspoint Parkway, Suite 200
Hoffman Estates, IL 60169 U.S.A.
Tel: (1) 847-843-7900/Fax: (1) 847-843-7787

OMRON (CHINA) CO., LTD.
Room 2211, Bank of China Tower,
200 Yin Cheng Zhong Road,
PuDong New Area, Shanghai, 200120, China
Tel: (86) 21-5037-2222/Fax: (86) 21-5037-2200

Authorized Distributor:

© OMRON Corporation 2019-2020 All Rights Reserved.
In the interest of product improvement,
specifications are subject to change without notice.

CSM_1_3
Cat. No. T227-E1-02

0520(0919)