

# Switch Mode Power Supply S8JX (15/35/50/100/150/300/600-W Models)

## S8JX-G Series

**Easy-to-use, Widely range from 15 W to 600 W (Output Voltage: 5 V to 48 V)**

- Easy Mounting:  
Front-mounted type, DIN rail-mounted type are available.  
Screw-mount at the top. (except 300-/600-W models)
- Safety standards:  
UL 508/60950-1  
cUL CSA C22.2 No. 107.1  
cUR CSA C22.2 No. 60950-1  
EN 50178 (= VDE 0160) Over voltage category III  
EN 60950-1 (= VDE 0805 Teil 1)
- EMC: Conforms to EN 61204-3.  
(EMI:EN55011 ClassA)
- Free-warranty period:  
2 years (3 years for 300-/600-W models)  
(Not including fans)
- Input conditions:  
The input voltage range of 15-W, 35-W, 50-W, 100-W, and 150-W models has been increased to 80 to 370 VDC (EC Directives and safety standards do not apply.).



Ro

For the most recent information on models that have been certified for safety standards, refer to your OMRON website.

## S8JX-P Series

**NEW**

**S8JX-P Series with EMI ClassB and Power Factor Correction is newly added to S8JX Series.**

- (Applicable to all capacities from 50 W to 600 W)
- Limits for harmonic current emissions (conforms to EN61000-3-2)
  - Conforms to EMI EN55011 Class B
  - Applicable to input free voltage: 100 to 240 VAC
  - Extended DC input voltage range: 80 to 370 VDC  
\* DC input is not subject to EC directives and safety standards.
  - Warranty period (charge free): 5 years (except for the fan)
  - Easy mounting: Front-mounting bracket type and DIN-Rail mounting type are included as standard with the product.  
Screw-mount at the top.  
(except 300-/600-W models)
  - Safety standards  
- UL508/60950-1, cUL CSA C22.2 No.107.1, cUR CSA C22.2 No.60950-1  
- EN50178 (=VDE0160) Over voltage category III  
EN60950-1 (=VDE0805 Teil1)

<Applicable only for 300 W and 600 W>

- High capacity application-covered functions are included as standard with the product.
- Alarm detection function, Remote control function, Remote sensing function

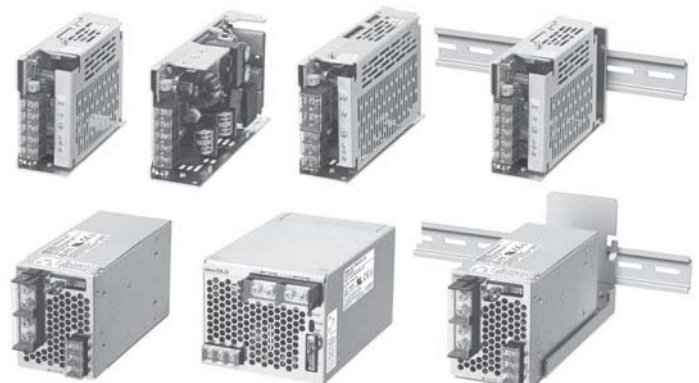

Ro

For the most recent information on models that have been certified for safety standards, refer to your OMRON website.

Refer to *Safety Precautions* on **page 55**.

### 300-/600-W (24 V) Models

Upcoming

The standards, performance and functions of 300-/600-W models detailed in this manual differ slightly from those at the time products were launched. Your understanding is appreciated.

S8JX-G

S8JX-P

Common Precautions

# S8JX

## Model Number Structure

### Model Number Legend

**Note:** Not all combinations are possible. Refer to *List of Models in Ordering Information* on page 3.

#### 15-/35-/50-/100-/150-W Models

S8JX-G

1 2 3 4

#### 1. Power Ratings

- 015: 15 W
- 035: 35 W
- 050: 50 W
- 100: 100 W
- 150: 150 W

#### 2. Output Voltage

- 05: 5 V
- 12: 12 V
- 15: 15 V
- 24: 24 V
- 48: 48 V

#### 3. Configuration (15/35/50/100/150 W model)

- None: Open type
- C: Covered

#### 4. Configuration/mounting

- None: Front-mounting
- D: DIN Rail-mounting

#### 300-/600-W Models

S8JX-G

1 2 3

#### 1. Power Ratings

- 300: 300 W
- 600: 600 W

#### 2. Output Voltage

- 05: 5V
- 12: 12 V
- 24: 24 V
- 48: 48 V

#### 3. Configuration/mounting (covered type)

- C: Front-mounting
- CD: DIN Rail-mounting

**Note:** Estimates can be provided for coatings and other specifications that are not given in the datasheet. Ask your OMRON representative for details.

## Ordering Information

### List of Models

Note: For details on normal stock models, contact your nearest OMRON representative.

#### DIN Rail-mounting \*



Configuration	Input voltage	Power ratings	Output voltage (VDC)	Output current	Built-in fan	Model
Covered Power Supplies	100 to 240 VAC (free) (80 to 370 VDC *) S8JX-G15005□□: Switchable between 100 to 120 VAC and 200 to 240 VAC. (DC power cannot be input.)	15 W	5 V	3 A	No	S8JX-G01505CD
			12 V	1.3 A		S8JX-G01512CD
			15 V	1 A		S8JX-G01515CD
			24 V	0.65 A		S8JX-G01524CD
			48 V	0.35 A		S8JX-G01548CD
		35 W	5 V	7 A		S8JX-G03505CD
			12 V	3 A		S8JX-G03512CD
			15 V	2.4 A		S8JX-G03515CD
			24 V	1.5 A		S8JX-G03524CD
			48 V	0.75 A		S8JX-G03548CD
		50 W	5 V	10 A		S8JX-G05005CD
			12 V	4.2 A		S8JX-G05012CD
			24 V	2.1 A		S8JX-G05024CD
		100 W	48 V	1.1 A		S8JX-G05048CD
			5 V	20 A		S8JX-G10005CD
			12 V	8.5 A		S8JX-G10012CD
		150 W	24 V	4.5 A		S8JX-G10024CD
			48 V	2.1 A		S8JX-G10048CD
			5 V	30 A		S8JX-G15005CD
			12 V	13 A		S8JX-G15012CD
	24 V		6.5 A	S8JX-G15024CD		
	300 W	48 V	3.3 A	S8JX-G15048CD		
		5 V	60 A	S8JX-G30005CD		
		12 V	27 A	S8JX-G30012CD		
24 V		14A	S8JX-G30024CD			
100 to 120 VAC 200 to 240 VAC (Switchable)	300 W	48 V	7A	No	S8JX-G30048CD	

\* The range for compliance with EC Directives and safety standards (UL, EN, etc.) is 100 to 240 VAC (85 to 264 VAC).

#### DIN Rail-mounting \*



Configuration	Input voltage	Power ratings	Output voltage (VDC)	Output current	Built-in fan	Model
Open type Power Supplies	100 to 240 VAC (free) (80 to 370 VDC *) S8JX-G15005□□: Switchable between 100 to 120 VAC and 200 to 240 VAC. (DC power cannot be input.)	15 W	5 V	3 A	No	S8JX-G01505D
			12 V	1.3 A		S8JX-G01512D
			15 V	1 A		S8JX-G01515D
			24 V	0.65 A		S8JX-G01524D
			48 V	0.35 A		S8JX-G01548D
		35 W	5 V	7 A		S8JX-G03505D
			12 V	3 A		S8JX-G03512D
			15 V	2.4 A		S8JX-G03515D
			24 V	1.5 A		S8JX-G03524D
			48 V	0.75 A		S8JX-G03548D
		50 W	5 V	10 A		S8JX-G05005D
			12 V	4.2 A		S8JX-G05012D
			24 V	2.1 A		S8JX-G05024D
		100 W	48 V	1.1 A		S8JX-G05048D
			5 V	20 A		S8JX-G10005D
			12 V	8.5 A		S8JX-G10012D
		150 W	24 V	4.5 A		S8JX-G10024D
			48 V	2.1 A		S8JX-G10048D
			5 V	30 A		S8JX-G15005D
			12 V	13 A		S8JX-G15012D
	24 V		6.5 A	S8JX-G15024D		
	300 W	300 W	48 V	3.3 A	S8JX-G15048D	

\* The range for compliance with EC Directives and safety standards (UL, EN, etc.) is 100 to 240 VAC (85 to 264 VAC).

## Front-mounting \*



Configuration	Input voltage	Power ratings	Output voltage (VDC)	Output current	Built-in fan	Front-mounting bracket	Model			
Covered Power Supplies	100 to 240 VAC (free) (80 to 370 VDC *) S8JX-G15005□□□: Switchable between 100 to 120 VAC and 200 to 240 VAC. (DC power cannot be input.)	15 W	5 V	3 A	No	Provided	S8JX-G01505C			
			12 V	1.3 A			S8JX-G01512C			
			15 V	1 A			S8JX-G01515C			
			24 V	0.65 A			S8JX-G01524C			
			48 V	0.35 A			S8JX-G01548C			
		35 W	5 V	7 A			S8JX-G03505C			
			12 V	3 A			S8JX-G03512C			
			15 V	2.4 A			S8JX-G03515C			
			24 V	1.5 A			S8JX-G03524C			
			48 V	0.75 A			S8JX-G03548C			
		50 W	5 V	10 A			S8JX-G05005C			
			12 V	4.2 A			S8JX-G05012C			
			24 V	2.1 A			S8JX-G05024C			
			48 V	1.1 A			S8JX-G05048C			
		100 W	5 V	20 A			S8JX-G10005C			
			12 V	8.5 A			S8JX-G10012C			
			24 V	4.5 A			S8JX-G10024C			
			48 V	2.1 A			S8JX-G10048C			
		150 W	5 V	30 A			S8JX-G15005C			
			12 V	13 A			S8JX-G15012C			
			24 V	6.5 A			S8JX-G15024C			
			48 V	3.3 A			S8JX-G15048C			
		100 to 120 VAC 200 to 240 VAC (Switchable)	300 W	5 V			60 A	Yes	No	S8JX-G30005C
				12 V			27 A			S8JX-G30012C
	24 V			14A	S8JX-G30024C					
	48 V			7A	S8JX-G30048C					
	600 W		5 V	120A	Yes	S8JX-G60005C				
			12 V	53A		S8JX-G60012C				
			24 V	27A		S8JX-G60024C				
			48 V	13A		S8JX-G60048C				

\* The range for compliance with EC Directives and safety standards (UL, EN, etc.) is 100 to 240 VAC (85 to 264 VAC).



## Front-mounting \*



Configuration	Input voltage	Power ratings	Output voltage (VDC)	Output current	Built-in fan	Front-mounting bracket	Model
Open type Power Supplies	100 to 240 VAC (free) (80 to 370 VDC *) S8JX-G15005□□: Switchable between 100 to 120 VAC and 200 to 240 VAC. (DC power cannot be input.)	15 W	5 V	3 A	No	Provided	S8JX-G01505
			12 V	1.3 A			S8JX-G01512
			15 V	1 A			S8JX-G01515
			24 V	0.65 A			S8JX-G01524
			48 V	0.35 A			S8JX-G01548
		35 W	5 V	7 A			S8JX-G03505
			12 V	3 A			S8JX-G03512
			15 V	2.4 A			S8JX-G03515
			24 V	1.5 A			S8JX-G03524
			48 V	0.75 A			S8JX-G03548
		50 W	5 V	10 A			S8JX-G05005
			12 V	4.2 A			S8JX-G05012
			24 V	2.1 A			S8JX-G05024
			48 V	1.1 A			S8JX-G05048
		100 W	5 V	20 A			S8JX-G10005
			12 V	8.5 A			S8JX-G10012
			24 V	4.5 A			S8JX-G10024
			48 V	2.1 A			S8JX-G10048
		150 W	5 V	30 A			S8JX-G15005
			12 V	13 A			S8JX-G15012
			24 V	6.5 A			S8JX-G15024
			48 V	3.3 A			S8JX-G15048

\* The range for compliance with EC Directives and safety standards (UL, EN, etc.) is 100 to 240 VAC (85 to 264 VAC).

## Ratings, Characteristics, and Functions

Item		Input specification		100 to 240 V input		
		Power ratings *1		15 W	35 W	
Efficiency				68% min.	73% min.	
Input	Voltage *2		100 to 240 VAC (allowable range: 85 to 264 VAC)			
			80 to 370 VDC *9			
	Frequency *2		50/60 Hz (47 to 450 Hz)			
	Current *3		100 V input	0.4 A max.	1 A max.	
			200 V input	0.25 A max.	0.6 A max.	
	Power factor		---			
	Harmonic current emissions		---			
	Leakage current *3		100 V input	0.5 mA max.		
			200 V input	1 mA max.		
	Inrush current (for a cold start at 25°C) *3		100 V input	20 A max.		
200 V input			40 A max.			
Noise filter		Yes				
Output *4	Voltage adjustment range *5		-10% to 15% (with V. ADJ) (48-V models: ±10%)			
	Ripple *3		2% (p-p) max.			
	Input variation influence		0.4% max. with AC input voltage			
	Load variation influence		0.8% max. (0 to 100% load, rated input voltage)			
	Temperature variation influence		0.05%/°C max. (at rated input and output)			
	Startup time		500 ms max. (up to 90% of output voltage at rated input and output)			
	Hold time *3		20 ms min.			
Additional functions	Overload protection *6		105% to 175% of rated load current, voltage drop, intermittent, automatic reset			
	Overvoltage protection *7		Yes			
	Overheat protection		No			
	Parallel operation		No (However, backup operation is possible; external diodes required.)			
	Series operation		Yes (For up to two Power Supplies; external diodes required.)			
Protective circuit operation indicator		No				
Other	Ambient operating temperature		Refer to the derating curve in <i>Engineering Data</i> on page 17 (with no icing or condensation).			
	Storage temperature		-25 to 65°C (with no icing or condensation)			
	Ambient operating humidity		25% to 85% (Storage humidity: 25% to 90%)			
	Dielectric strength		3.0 kVAC for 1 min. (between all inputs and outputs; detection current: 20 mA) 2.0 kVAC for 1 min. (between all inputs and PE terminals; detection current: 20 mA) 1.0 kVAC for 1 min. (between all outputs and PE terminals; detection current: 20 mA)			
	Insulation resistance		100 MΩ min. (between all outputs and all inputs/PE terminals) at 500 VDC			
	Vibration resistance		10 to 55 Hz, 0.375-mm single amplitude for 2 h each in X, Y, and Z directions			
	Shock resistance		150 m/s <sup>2</sup> , 3 times each in ±X, ±Y, ±Z directions			
	Output indicator		Yes (Color: Green)			
	EMI	Conducted Emissions		Conforms to EN 55011 Group 1 Class A and based on FCC Class A *9		
		Radiated Emissions		Conforms to EN 55011 Group 1 Class A *9		
	EMS	Electrostatic Discharge		Conforms to EN61000-4-2		
		Radiated Electromagnetic Field		Conforms to EN61000-4-3		
		Electrical Fast Transient/Burst		Conforms to EN61000-4-4		
Surge		Conforms to EN61000-4-5				
Conducted Disturbance		Conforms to EN61000-4-6				
Voltage Dips/Short Interruptions		Conforms to EN61000-4-11				
Approved standards *9		UL Listed: UL 508 (Listing), UL UR: UL 60950-1 (Recognition) cUL Listed: CSA C22.2 No.107.1 cUR: CSA C22.2 No. 60950-1 EN/VDE: EN50178 (= VDE 0160) Over voltage category III, EN 60950-1 (= VDE 0805 Teil 1) (Terminal block: Based on DIN 50274 (VDE 0660-514))				
SEMI		SEMI F47-0200 (200-VAC input)				
Weight *8		250 g max.				

\*1. When a load is connected that has a built-in DC-DC converter, the overload protection may operate at startup and the Power Supply may not start. Refer to *Overload Protection on page 20*.

\*2. Do not use an Inverter output for the Power Supply. Inverters with an output frequency of 50/60 Hz are available, but the rise in the internal temperature of the Power Supply may result in ignition or burning.

\*3. Rated input voltage: 100 or 200 VAC at 100% load.

\*4. Output characteristics: Specified at power supply output terminals.

\*5. If the output voltage adjuster (V. ADJ) is turned, the voltage will increase by more than the allowable voltage range. When adjusting the output voltage, confirm the actual output voltage from the Power Supply and be sure that load is not damaged.

\*6. For details, refer to *Overload Protection on page 20*.

\*7. To reset the protection, turn OFF the input power for seven minutes or longer and then turn it back ON.

\*8. The weight indicated is for Front-mounting, Open-frame Power Supply.

\*9. The range for compliance with EC Directives and safety standards (UL, EN, etc.) is 100 to 240 VAC (85 to 264 VAC).

Item	Input specification		100 to 240 V input		
	Power ratings *1		50 W	100 W	
Efficiency	5-V Models		76% min.	76% min.	
	12-V Models		81% min.	81% min.	
	24-V Models		83% min.	83% min.	
	48-V Models		82% min.	83% min.	
Input	Voltage *2		100 to 240 VAC (allowable range: 85 to 264 VAC) 80 to 370 VDC *9		
	Frequency *2		50/60 Hz (47 to 450 Hz)		
	Current *3	100 V input	1.4 A max.	2.5 A max.	
		200 V input	0.8 A max.	1.5 A max.	
	Power factor		---		
	Harmonic current emissions		---		
	Leakage current *3	100 V input	0.5 mA max.		
		200 V input	1 mA max.		
	Inrush current (for a cold start at 25°C) *3	100 V input	20 A max.		
		200 V input	40 A max.		
Noise filter		Yes			
Output *4	Voltage adjustment range *5		-10% to 15% (with V. ADJ) (48-V models: ±10%)		
	Ripple *3		2% (p-p) max.		
	Input variation influence		0.4% max. (with AC input voltage)		
	Load variation influence		0.8% max. (0 to 100% load, rated input voltage)		
	Temperature variation influence		0.05%/°C max. (at rated input and output)		
	Startup time		500 ms max. (up to 90% of output voltage at rated input and output)		
	Hold time *3		20 ms min.		
Additional functions	Overload protection *6		105% to 175% of rated load current, voltage drop, intermittent, automatic reset		
	Overvoltage protection *7		Yes		
	Overheat protection		No		
	Parallel operation		No (However, backup operation is possible; external diodes required.)		
	Series operation		Yes (For up to two Power Supplies; external diodes required.)		
	Protective circuit operation indicator		No		
Other	Ambient operating temperature		Refer to the derating curve in <i>Engineering Data</i> on page 17 (with no icing or condensation).		
	Storage temperature		-25 to 65°C (with no icing or condensation)		
	Ambient operating humidity		25% to 85% (Storage humidity: 25% to 90%)		
	Dielectric strength		3.0 kVAC for 1 min. (between all inputs and outputs; detection current: 20 mA) 2.0 kVAC for 1 min. (between all inputs and PE terminals; detection current: 20 mA) 1.0 kVAC for 1 min. (between all outputs and PE terminals; detection current: 20 mA)		
	Insulation resistance		100 MΩ min. (between all outputs and all inputs/PE terminals) at 500 VDC		
	Vibration resistance		10 to 55 Hz, 0.375-mm single amplitude for 2 h each in X, Y, and Z directions		
	Shock resistance		150 m/s <sup>2</sup> , 3 times each in ±X, ±Y, ±Z directions		
	Output indicator		Yes (Color: Green)		
	EMI	Conducted Emissions		Conforms to EN 55011 Group 1 Class A and based on FCC Class A *9	
		Radiated Emissions		Conforms to EN 55011 Group 1 Class A *9	
	EMS	Electrostatic Discharge		Conforms to EN61000-4-2	
		Radiated Electromagnetic Field		Conforms to EN61000-4-3	
		Electrical Fast Transient/Burst		Conforms to EN61000-4-4	
		Surge		Conforms to EN61000-4-5	
		Conducted Disturbance		Conforms to EN61000-4-6	
	Voltage Dips/Short Interruptions		Conforms to EN61000-4-11		
	Approved standards *9		UL Listed: UL 508 (Listing), UL UR: UL 60950-1 (Recognition) cUL Listed: CSA C22.2 No.107.1 cUR: CSA C22.2 No. 60950-1 EN/VDE: EN50178 (= VDE 0160) Over voltage category III, EN 60950-1 (= VDE 0805 Teil 1) (Terminal block: Based on DIN 50274 (VDE 0660-514))		
SEMI		SEMI F47-0200 (200-VAC input)			
Weight *8		300 g max.	550 g max.		

\*1. When a load is connected that has a built-in DC-DC converter, the overload protection may operate at startup and the Power Supply may not start. Refer to *Overload Protection on page 20*.

\*2. Do not use an Inverter output for the Power Supply. Inverters with an output frequency of 50/60 Hz are available, but the rise in the internal temperature of the Power Supply may result in ignition or burning.

\*3. Rated input voltage: 100 or 200 VAC at 100% load.

\*4. Output characteristics: Specified at power supply output terminals.

\*5. If the output voltage adjuster (V. ADJ) is turned, the voltage will increase by more than the allowable voltage range. When adjusting the output voltage, confirm the actual output voltage from the Power Supply and be sure that load is not damaged.

\*6. For details, refer to *Overload Protection on page 20*.

\*7. To reset the protection, turn OFF the input power for seven minutes or longer and then turn it back ON.

\*8. The weight indicated is for Front-mounting, Open-frame Power Supply.

\*9. The range for compliance with EC Directives and safety standards (UL, EN, etc.) is 100 to 240 VAC (85 to 264 VAC).

Item	Input specification		100/200 V switchable	100 to 240 V input		
	Power ratings *1		150 W at 5 V	150 W at 12 V	150 W at 24 or 48 V	
Efficiency	5-V Models		78% min.	---	---	
	12-V Models		---	79% min.	---	
	24-V Models		---	---	86% min.	
	48-V Models		---	---	85% min.	
Input	Voltage *2		Switchable between 100 to 120 VAC (allowable range: 85 to 132 VAC) and 200 to 240 VAC (allowable range: 170 to 264 VAC).	100 to 240 VAC (allowable range: 85 to 264 VAC) 80 to 370 VDC *9		
	Frequency *2		50/60 Hz (47 to 450 Hz)			
	Current *3	100 V input	3.5 A max.	3.6 A max.	3.5 A max.	
		200 V input	2.1 A max.	2.2 A max.	2.1 A max.	
	Power factor		---			
	Harmonic current emissions		---			
	Leakage current *3	100 V input	0.5 mA max.			
		200 V input	1 mA max.			
	Inrush current (for a cold start at 25°C) *3	100 V input	20 A max.			
		200 V input	40 A max.			
Noise filter		Yes				
Output *4	Voltage adjustment range *5		-10% to 15% (with V. ADJ) (48-V models: ±10%)			
	Ripple *3		2% (p-p) max.			
	Input variation influence		0.4% max. (with AC input voltage)			
	Load variation influence		0.8% max. (0 to 100% load, rated input voltage)			
	Temperature variation influence		0.05%/°C max. (at rated input and output)			
	Startup time		500 ms max. (up to 90% of output voltage at rated input and output)			
	Hold time *3		20 ms min.			
Additional functions	Overload protection *6		105% to 175% of rated load current, voltage drop, automatic reset	105% to 175% of rated load current, voltage drop, intermittent, automatic reset		
	Overvoltage protection *7		Yes			
	Overheat protection		No			
	Parallel operation		No			
	Series operation		Yes (For up to two Power Supplies; external diodes required.)			
Protective circuit operation indicator		No				
Other	Ambient operating temperature		Refer to the derating curve in <i>Engineering Data</i> on page 17 (with no icing or condensation).			
	Storage temperature		-25 to 65°C (with no icing or condensation)			
	Ambient operating humidity		25% to 85% (Storage humidity: 25% to 90%)			
	Dielectric strength		3.0 kVAC for 1 min. (between all inputs and outputs; detection current: 20 mA) 2.0 kVAC for 1 min. (between all inputs and PE terminals; detection current: 20 mA) 1.0 kVAC for 1 min. (between all outputs and PE terminals; detection current: 20 mA)			
	Insulation resistance		100 MΩ min. (between all outputs and all inputs/PE terminals) at 500 VDC			
	Vibration resistance		10 to 55 Hz, 0.375-mm single amplitude for 2 h each in X, Y, and Z directions			
	Shock resistance		150 m/s <sup>2</sup> , 3 times each in ±X, ±Y, ±Z directions			
	Output indicator		Yes (Color: Green)			
	EMI	Conducted Emissions		Conforms to EN 55011 Group 1 Class A and based on FCC Class A *9		
		Radiated Emissions		Conforms to EN 55011 Group 1 Class A *9		
	EMS	Electrostatic Discharge		Conforms to EN61000-4-2		
		Radiated Electromagnetic Field		Conforms to EN61000-4-3		
		Electrical Fast Transient/Burst		Conforms to EN61000-4-4		
		Surge		Conforms to EN61000-4-5		
		Conducted Disturbance		Conforms to EN61000-4-6		
		Voltage Dips/Short Interruptions		Conforms to EN61000-4-11		
	Approved standards *9		UL Listed: UL 508 (Listing), UL UR: UL 60950-1 (Recognition) cUL Listed: CSA C22.2 No.107.1 cUR: CSA C22.2 No. 60950-1 EN/VDE: EN50178 (= VDE 0160), Over voltage category III, EN 60950-1 (= VDE 0805 Teil 1) (Terminal block: Based on DIN 50274 (VDE 0660-514))			
SEMI		---	SEMI F47-0200 (200-VAC input)			
Weight *8		800 g max.	700 g max.	600 g max.		

- \*1. When a load is connected that has a built-in DC-DC converter, the overload protection may operate at startup and the Power Supply may not start. Refer to *Overload Protection on page 20*.
- \*2. Do not use an Inverter output for the Power Supply. Inverters with an output frequency of 50/60 Hz are available, but the rise in the internal temperature of the Power Supply may result in ignition or burning.
- \*3. Rated input voltage: 100 or 200 VAC at 100% load.
- \*4. Output characteristics: Specified at power supply output terminals.
- \*5. If the output voltage adjuster (V. ADJ) is turned, the voltage will increase by more than the allowable voltage range. When adjusting the output voltage, confirm the actual output voltage from the Power Supply and be sure that load is not damaged.
- \*6. For details, refer to *Overload Protection on page 20*.
- \*7. To reset the protection, turn OFF the input power for seven minutes or longer and then turn it back ON.
- \*8. The weight indicated is for Front-mounting, Open-frame Power Supply.
- \*9. The range for compliance with EC Directives and safety standards (UL, EN, etc.) is 100 to 240 VAC (85 to 264 VAC).

Item	Input specification		100/200 V (Selected)		
	Power ratings *1		300 W	600 W	
Efficiency	5V models		71% min.	72% min.	
	12V models		75% min.	78% min.	
	24V models		82% min.	80% min.	
	48V models		82% min.	80% min.	
Input	Voltage *2		100 to 120 VAC (allowable range: 85 to 132 VAC) 200 to 240 VAC (allowable range: 170 to 264 VAC) (Switchable)		
	Frequency *2		50/60 Hz (47 to 450 Hz)		
	Current *3	100 V input	8 A max.	16 A max.(5V, 12V, 48V) 14 A max.(24V)	
		200 V input	4.5 A max.	9 A max.(5V, 12V, 48V) 8 A max.(24V)	
	Power factor		---		
	Harmonic current emissions		---		
	Leakage current *3	100 V input	0.5 mA max.		
		200 V input	1 mA max.		
	Inrush current (for a cold start at 25°C) *3	100 V input	25 A max.	30 A max.	
		200 V input	50 A max.	60 A max.	
Noise filter		Yes			
Output *4	Voltage adjustment range *5		-10% to 15% (with V. ADJ) (48-V models: ±10%)		
	Ripple *3		2.8% (p-p) max.(5V) *6 2% (p-p) max.(12V, 24V, 48V)	3.8% (p-p) max.(5V) *6 2% (p-p) max.(12V) *6 2% (p-p) max.(24V, 48V)	
	Input variation influence		0.4% max.		
	Load variation influence		0.8% max. (0 to 100% load, rated input voltage)		
	Temperature variation influence		0.05%/°C max.		
	Startup time		650 ms max.	500 ms max.	
	Hold time *3		20 ms min.		
Additional functions	Overload protection *7		105% to 175% of rated load current, Inverted L voltage drop, the circuit will be shut OFF when the overload exceeds 5 s.(5V, 12V) *10 voltage drop, intermittent, automatic reset. (24V, 48V)	105% to 175% of rated load current, Inverted L voltage drop, the circuit will be shut OFF when the overload exceeds 5 s. *10	
	Overvoltage protection *8		Yes (5V, 12V) *10 Yes (24V, 48V) *10	Yes *10	
	Overheat protection		Yes (5V, 12V) *10 NO (24V, 48V) *10	Yes *10	
	Parallel operation		Yes (up to 5 units)		
	Series operation		Yes (For up to two Power Supplies; external diodes required.)		
	Protective circuit operation indicator		Yes (color: red) (5V, 12V) No (24V, 48V)	Yes (color: red)	
Other	Ambient operating temperature		Refer to the derating curve in <i>Engineering Data</i> on page 17 (with no icing or condensation).		
	Storage temperature		-25 to 65°C (with no icing or condensation)		
	Ambient operating humidity		25% to 85% (Storage humidity: 25% to 90%)		
	Dielectric strength		3.0 kVAC for 1 min. (between all inputs and outputs; detection current: 25 mA) 2.0 kVAC for 1 min. (between all inputs and PE terminals; detection current: 25 mA) 1.0 kVAC for 1 min. (between all outputs and PE terminals; detection current: 25 mA)		
	Insulation resistance		100 MΩ min. (between all outputs and all inputs/PE terminals) at 500 VDC		
	Vibration resistance		10 to 55 Hz, 0.375-mm single amplitude for 2 h each in X, Y, and Z directions		
	Shock resistance		150 m/s <sup>2</sup> , 3 times each in ±X, ±Y, ±Z directions		
	Output indicator		Yes (Color: Green)		
	EMI	Conducted Emissions *3		Conforms to EN 55011 Group 1 Class A and based on FCC Class A *11	
		Radiated Emissions		Conforms to EN 55011 Group 1 Class A *11 *12	
	EMS	Electrostatic Discharge		Conforms to EN61000-4-2	
		Radiated Electromagnetic Field		Conforms to EN61000-4-3	
		Electrical Fast Transient/Burst		Conforms to EN61000-4-4	
		Surge		Conforms to EN61000-4-5	
		Conducted Disturbance		Conforms to EN61000-4-6	
		Voltage Dips/Short Interruptions		Conforms to EN61000-4-11	
	Approved standards *13		UL UR: UL 508 (Recognition), UL 60950-1 (Recognition)		
cUR: CSA C22.2 No. 60950-1 EN/VDE: EN50178 (= VDE 0160), Over voltage category III, EN 60950-1 (= VDE 0805 Teil 1) (Terminal block: Based on DIN 50274 (VDE 0660-514))					
Weight *9		1,800 g max. (5V, 12V) 1,600 g max. (24V, 48V)	2,500 g max.		

- 
- \*1. When a load is connected that has a built-in DC-DC converter, the overload protection may operate at startup and the Power Supply may not start. Refer to *Overload Protection on page 20*.
  - \*2. Do not use an Inverter output for the Power Supply. Inverters with an output frequency of 50/60 Hz are available, but the rise in the internal temperature of the Power Supply may result in ignition or burning.
  - \*3. Rated input voltage: 100 or 200 VAC at 100% load.
  - \*4. Output characteristics: Specified at power supply output terminals.
  - \*5. If the output voltage adjuster (V. ADJ) is turned, the voltage will increase by more than the allowable voltage range. When adjusting the output voltage, confirm the actual output voltage from the Power Supply and be sure that load is not damaged.
  - \*6. Measurement methods are based on JEITA standard RC-9131A. Refer to *Ripple Noise Voltage on page 57*.
  - \*7. For details, refer to *Overload Protection on page 20*.
  - \*8. To reset the protection, turn OFF the input power for three minutes or longer and then turn it back ON.
  - \*9. The weight indicated is for Front-mounting Power Supply.
  - \*10. The protection-ON alarm indicator will light as soon as the output is interrupted. For resetting, turn OFF the input power, leave for more than three minutes, and then turn it back ON again.
  - \*11. Noise values depend on the wiring methods and other factors. Insert noise filters and cores in the input and output lines.
    - 300 W, 5 V: Two E04SR401938 (manufactured by SEIWA) on the output line.
    - 300 W, 12 V: One E04SR401938 (manufactured by SEIWA) on the output line.
    - 600 W, 5 V or 12 V: One FN2450G-16-61 (manufactured by Schaffner) on the input line.  
One E04RC613620 (manufactured by SEIWA) on the output line.
  - \*12. For the 600-W, 5-V and 12-V models, class A compliance was met with an aluminum plate placed under the Power Supply.
  - \*13. The range for compliance with EC Directives and safety standards (UL, EN, etc.) is 100 to 240 VAC (85 to 264 VAC).

# Connections

## Block Diagrams

S8JX-G01505 (15 W)

S8JX-G01512 (15 W)

S8JX-G01515 (15 W)

S8JX-G01524 (15 W)

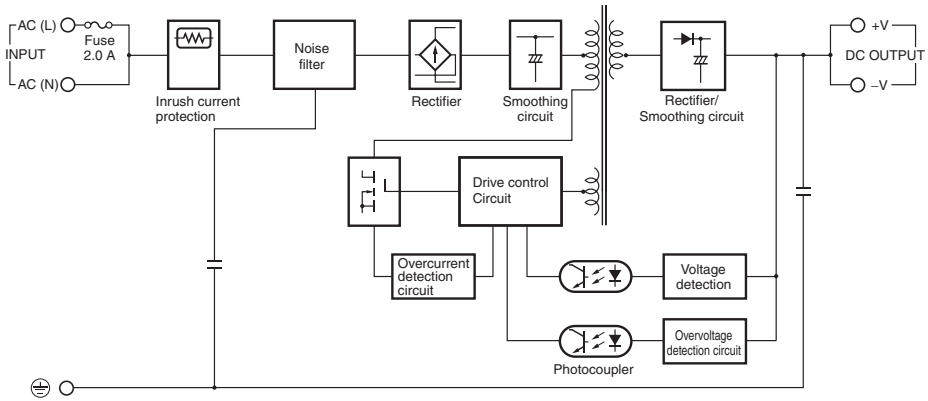

S8JX-G01548 (15 W)

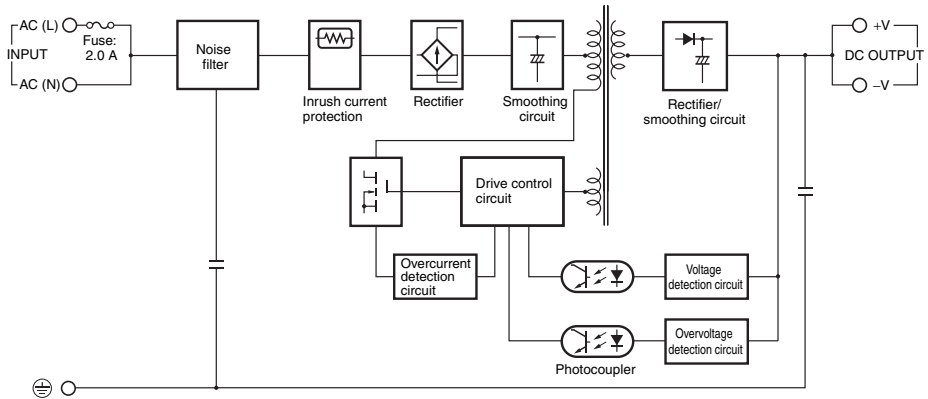

S8JX-G03505 (35 W)

S8JX-G03512 (35 W)

S8JX-G03515 (35 W)

S8JX-G03524 (35 W)

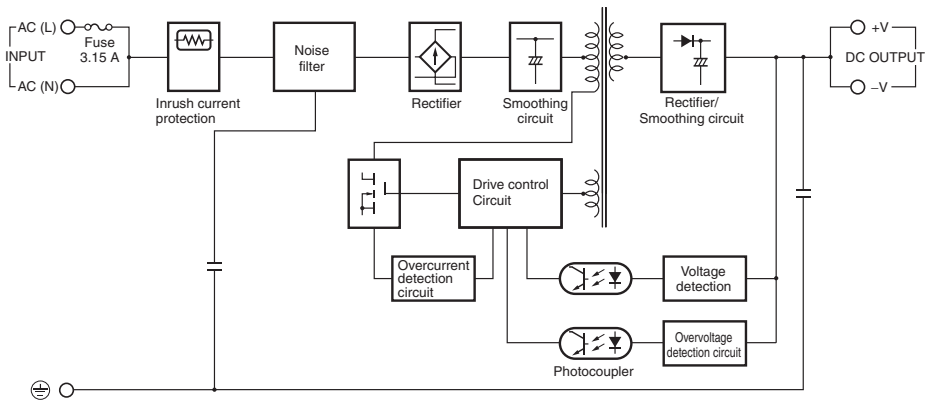

S8JX-G03548 (35 W)

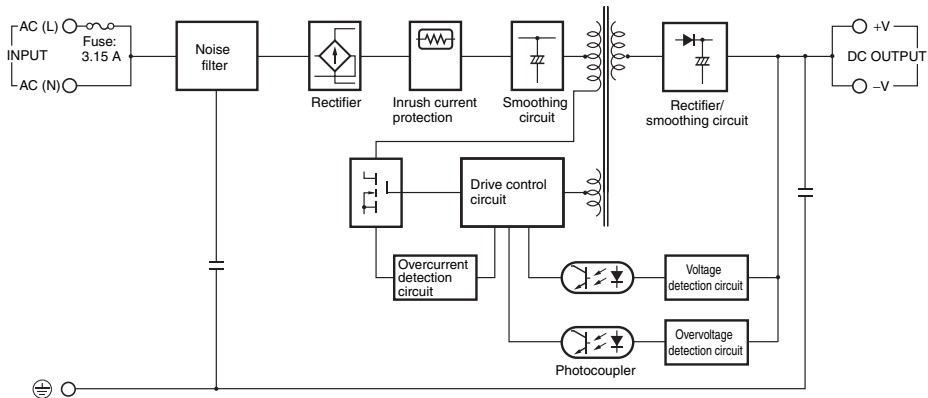

S8JX-G

S8JX-P

Common Precautions



# S8JX

S8JX-G

S8JX-G05005□□ (50 W)  
 S8JX-G05012□□ (50 W)  
 S8JX-G05024□□ (50 W)

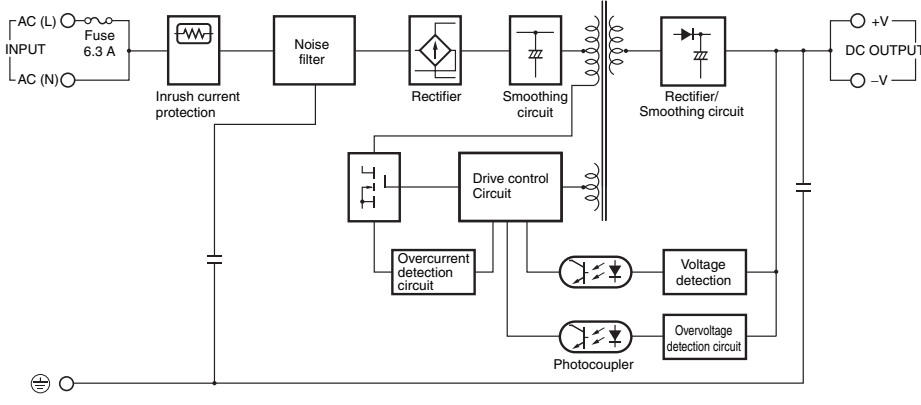

S8JX-P

S8JX-G05048□□ (50 W)

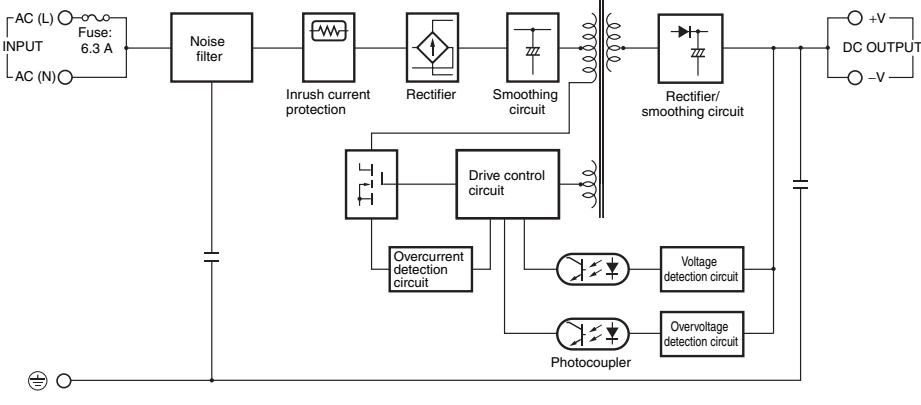

Common Precautions

S8JX-G100□□□□ (100 W)

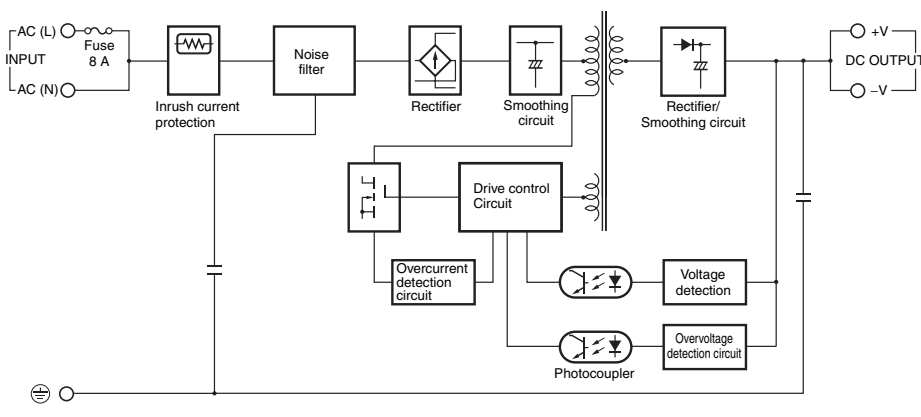

S8JX-G15005□□ (150 W)

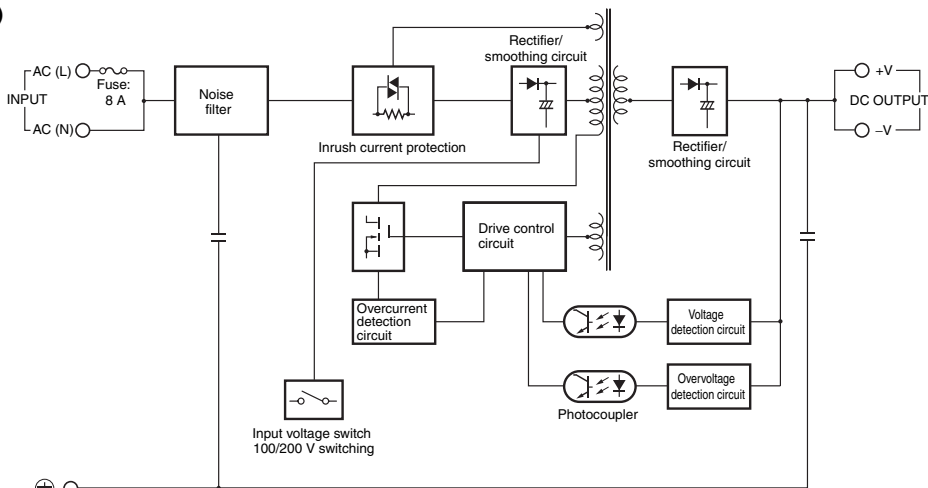

Note: Set the input voltage switch to "115V" for 100 to 120 VAC and to "230V" for 200 to 240 VAC.

S8JX-G15012□□ (150 W)  
S8JX-G15024□□ (150 W)  
S8JX-G15048□□ (150 W)

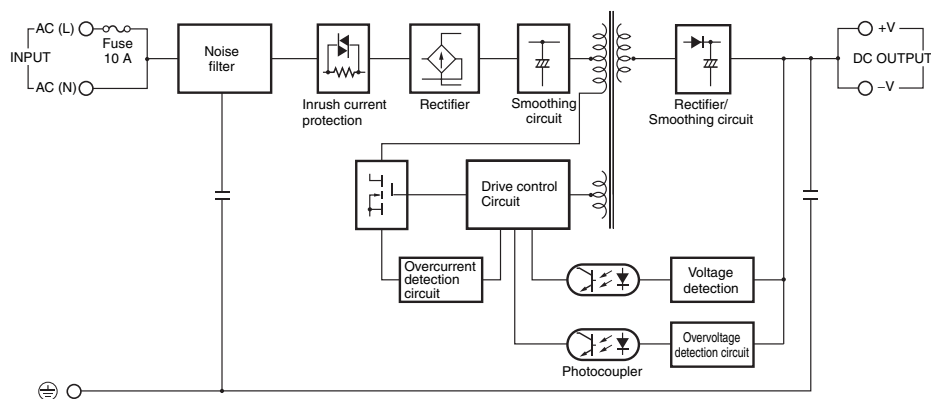

S8JX-G30005□□ (300 W)  
S8JX-G30012□□ (300 W)

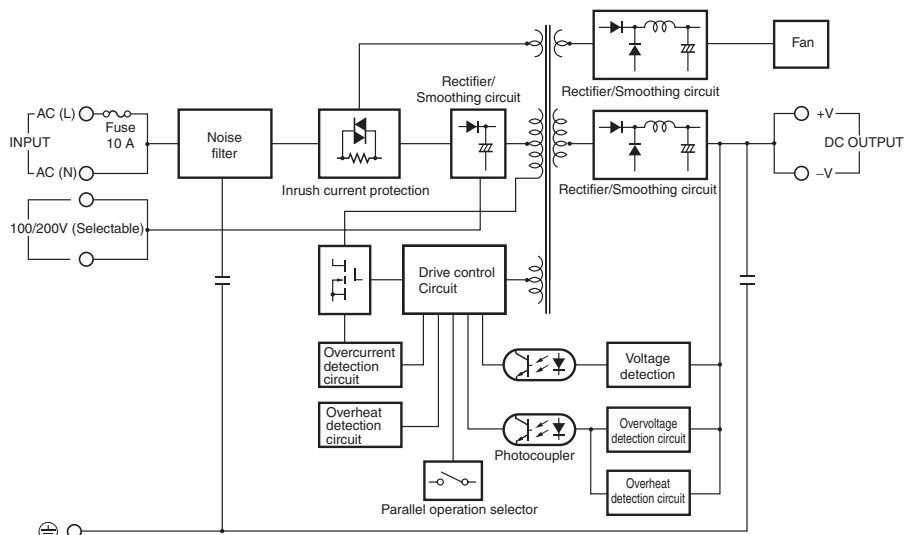

Note: Short-circuit the input voltage selector terminals if the input is 100 to 120 VAC. Keep the terminals open if the input is 200 to 240 VAC.

S8JX-G30024 (300 W)  
 S8JX-G30048 (300 W)

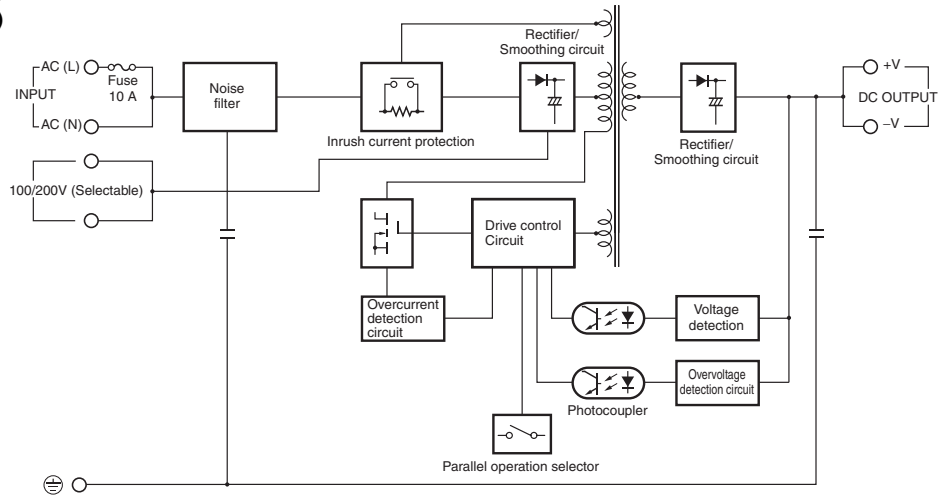

**Note:** Short-circuit the input voltage selector terminals if the input is 100 to 120 VAC.  
 Keep the terminals open if the input is 200 to 240 VAC.

S8JX-G60005 (600 W)  
 S8JX-G60012 (600 W)  
 S8JX-G60048 (600 W)

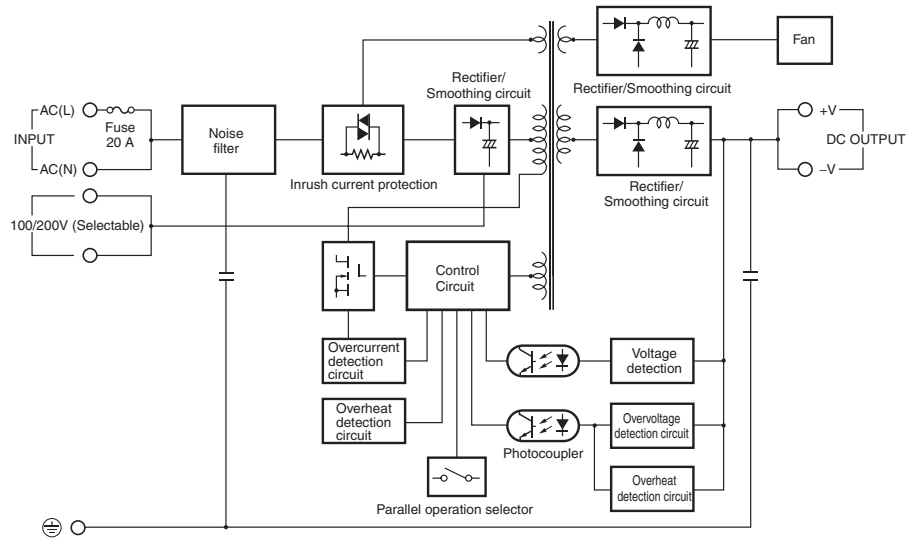

**Note:** Short-circuit the input voltage selector terminals if the input is 100 to 120 VAC.  
 Keep the terminals open if the input is 200 to 240 VAC.

S8JX-G60024 (600 W)

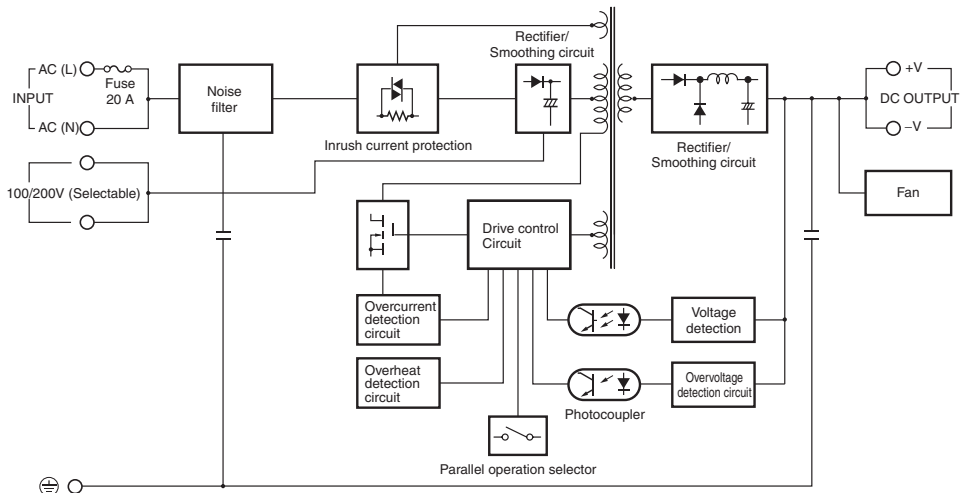

**Note:** Short-circuit the input voltage selector terminals if the input is 100 to 120 VAC.  
 Keep the terminals open if the input is 200 to 240 VAC.

# Construction and Nomenclature

## Nomenclature

### 15-/35-/50-/100-/150-W Models

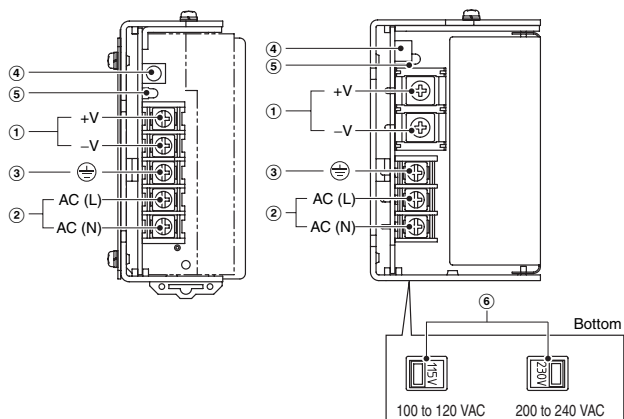

Note: The S8JX-G05024CD is shown above.

Note: The S8JX-G15005C is shown above.

No.	Name	Function
1	DC Output Terminals (-V), (+V)	Connect the load lines to these terminals.
2	AC Input Terminals (L), (N)	Connect the input lines to these terminals. *1
3	Protective Earth Terminal (PE) (⊕)	Connect the ground line to these terminals. *2
4	Output Voltage Adjuster (V. ADJ)	It is possible to increase or decrease the output voltage.
5	Output Indicator (DC ON: Green)	Lights green while a direct current (DC) output is ON.
6	Input voltage switch *3	Switches the internal circuits according to the input voltage. "115V": 100 to 120 VAC "230V": 200 to 240 VAC

- \*1. The fuse is located on the (L) side. It is NOT user-replaceable. For a DC power input, connect the low side to the positive (+) terminal.
- \*2. This is the protective earth terminal specified in the safety standards. Always ground this terminal.
- \*3. This item is applicable only to the S8JX-G15005□□.

### 300-W 5V, 12V Model

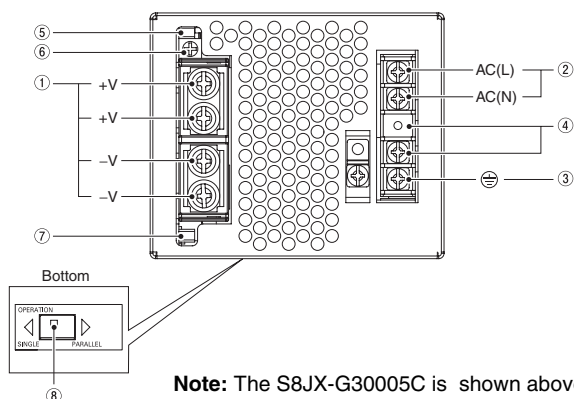

Note: The S8JX-G30005C is shown above.

### 300-W Model

No.	Name	Function
1	DC Output Terminals (+V), (-V)	Connect the load lines to these terminals.
2	AC Input Terminals (L), (N)	Connect the input lines to these terminals. *1
3	Protective Earth Terminal (PE) (⊕)	Connect the ground line to these terminals. *2
4	Input Voltage Selector Terminals	Short-circuit the terminals if the input is 100 to 120 VAC and open the terminals if the input is 200 to 240 VAC.
5	Output Indicator (DC ON: Green)	Lights green while a direct current (DC) output is ON.
6	Output Voltage Adjuster (V. ADJ)	It is possible to increase or decrease the output voltage.
7	Protection-ON Alarm Indicator (ALM: Red)	The red indicator will be lit if the overvoltage or overheat protection circuit is triggered. This indicator will also be lit when overload is detected. *3
8	Selector of Parallel Operation	Set the selector to PARALLEL if the Units are in parallel operation.

- \*1. The fuse is located on the (L) side. It is NOT user-replaceable.
- \*2. This is the protective earth terminal specified in the safety standards. Always ground this terminal.
- \*3. This is not applicable to 24-V and 48-V models.

### 300-W 24V, 48V Model

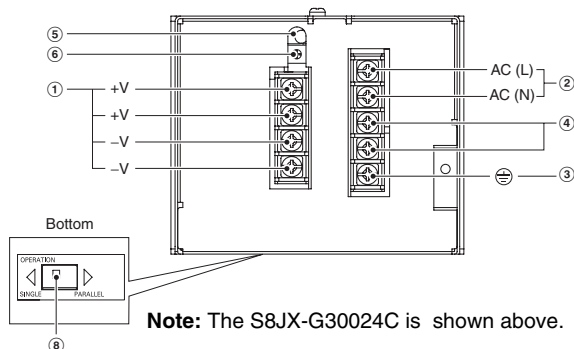

Note: The S8JX-G30024C is shown above.

**600-W 5V, 12V Model**

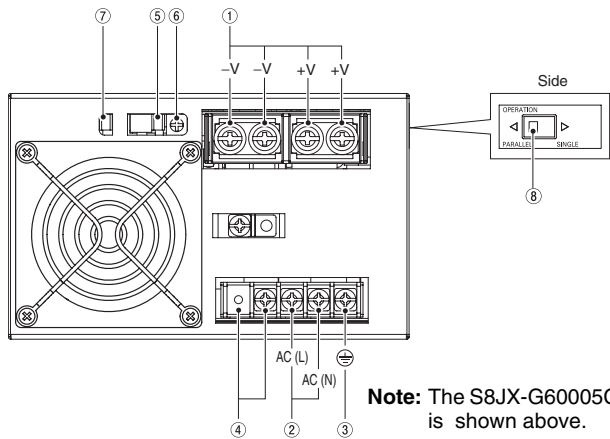

**600-W 24V, 48V Model**

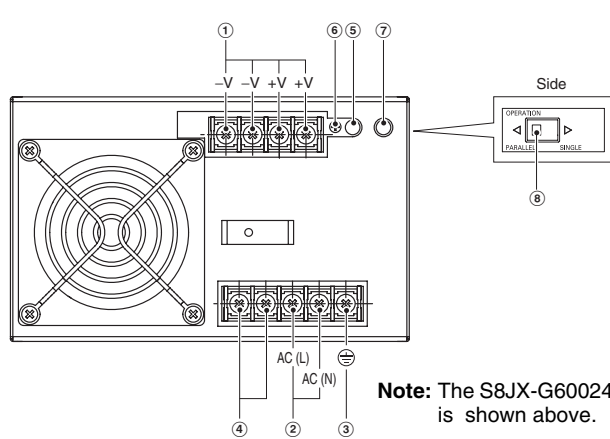

**600-W Model**

No.	Name	Function
1	DC Output Terminals (+V), (-V)	Connect the load lines to these terminals.
2	AC Input Terminals (L), (N)	Connect the input lines to these terminals. *1
3	Protective Earth Terminal (PE) (⊕)	Connect the ground line to these terminals. *2
4	Input Voltage Selector Terminals	Short-circuit the terminals if the input is 100 to 120 VAC and open the terminals if the input is 200 to 240 VAC.
5	Output Indicator (DC ON: Green)	Lights green while a direct current (DC) output is ON.
6	Output Voltage Adjuster (V. ADJ)	It is possible to increase or decrease the output voltage.
7	Protection-ON Alarm Indicator (ALM: Red)	The red indicator will be lit if the overvoltage or overheat protection circuit is triggered. This indicator will also be lit when overload is detected.
8	Selector of Parallel Operation	Set the selector to PARALLEL if the Units are in parallel operation.

\*1. The fuse is located on the (L) side. It is NOT user-replaceable.

\*2. This is the protective earth terminal specified in the safety standards. Always ground this terminal.

**Reference Values**

	Value
<b>Reliability (MTBF)</b>	15 W: 300,000 hrs
	35 W: 300,000 hrs
	50 W: 300,000 hrs
	100 W: 270,000 hrs
	150 W: 240,000 hrs for 5 V and 12 V
	150 W: 250,000 hrs for 24 V and 48 V
	300 W: 200,000 hrs for 5 V and 12 V
300 W: 400,000 hrs for 24 V and 48 V	
600 W: 170,000 hrs	
<b>Definition</b>	MTBF stands for Mean Time Between Failures, which is calculated according to the probability of accidental device failures, and indicates reliability of devices. Therefore, it does not necessarily represent a life of the product.
<b>Life expectancy</b>	10 yrs. min.
<b>Definition</b>	The life expectancy indicates average operating hours under the ambient temperature of 40°C and a load rate of 50%. Normally this is determined by the life expectancy of the built-in aluminum electrolytic capacitor.

# Engineering Data

## Derating Curves (Standard Mounting)

### 15-/35-/50-/100-/150-W Models

#### Open type Power Supplies

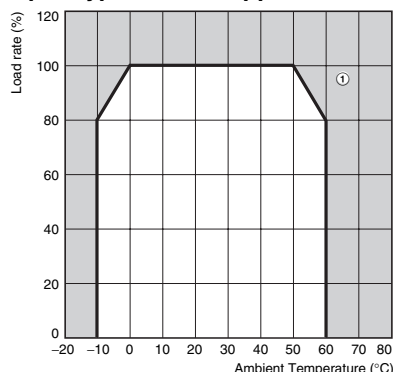

#### Covered Power Supplies

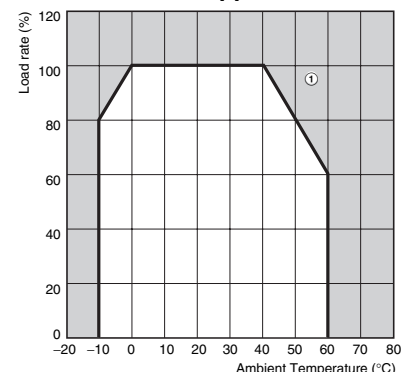

**Note: 1.** Internal parts may occasionally deteriorate or be damaged. Do not use the Power Supply in areas outside the derating curve (i.e., the area shown by shading ① in the above graph).

**2.** If there is a derating problem, use forced air-cooling.

**3.** For Customers Using a DC Input

When using an input voltage of less than 100 VDC, reduce the load calculated with the above derating curve by at least the following coefficients.

35-W and 100-W (5-V or 12-V output) models: 0.8

50-W/150-W models:

0.85 (DC power cannot be input only to the S8JX-G15005□□.)

15-W and 100-W (24-V or 48-V output):

0.9

### 300-/600-W 24V, 48V Models

#### Single Unit Operation

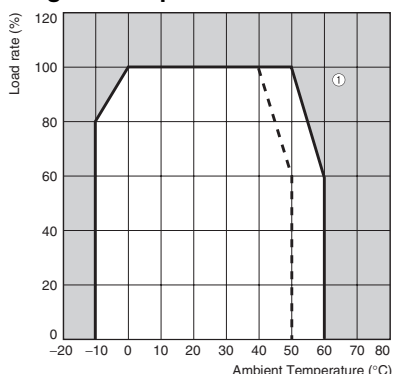

#### Parallel Operation

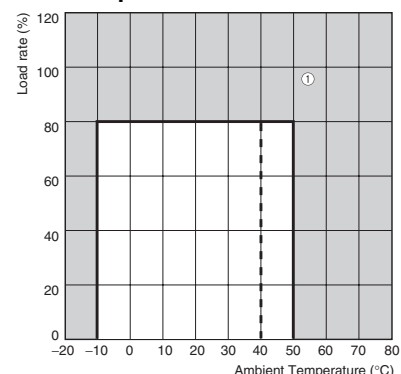

— Solid line Front-mounting, Bottom-mounting, DIN Rail mounting, Side mounting (300W 5V, 12V/ 600W 24V, 48V Models)

- - - Dotted line Side mounting (300W 24V, 48V Models)

**Note: 1.** Internal parts may occasionally deteriorate or be damaged. Do not use the Power Supply in areas outside the derating curve (i.e., the area shown by shading ① in the above graph).

**2.** If there is a derating problem, use forced air-cooling.

### 600-W 5V, 12V Models

#### Single Unit Operation

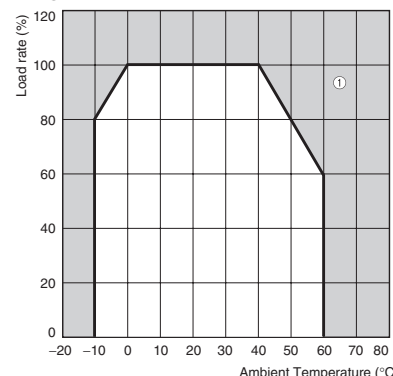

#### Parallel Operation

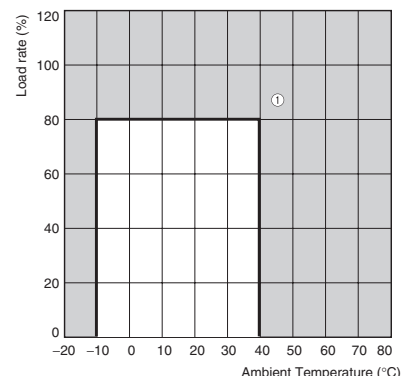

**Note: 1.** Internal parts may occasionally deteriorate or be damaged. Do not use the Power Supply in areas outside the derating curve (i.e., the area shown by shading ① in the above graph).

## Mounting

### 15-/35-/50-/100-/150-W Models

The following three mounting methods are possible.

- Ⓐ. Front-mounting: Refer to *Mounting Bracket Provided with Front-mounting Power Supplies* Ⓐ on page 26.
- Ⓑ. Bottom-mounting
- Ⓒ. Side-mounting

**Note:** Additional mounting methods are also available using DIN Rail-mounting models.

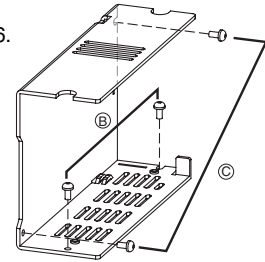

## Standard Mounting

### 15-/35-/50-/100-/150-W Models

Front-mounting

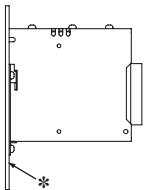

DIN Rail-mounting

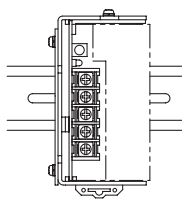

Bottom-mounting

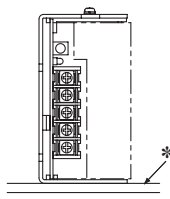

Vertical Side-mounting

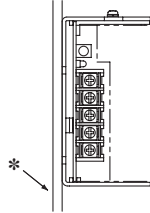

Horizontal Side-mounting

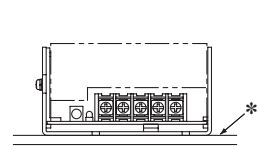

- Note:**
1. Improper mounting will interfere with heat dissipation and may occasionally result in deterioration or damage of internal parts. Use the standard mounting method only.
  2. When mounting the Power Supply, mounting it to a metal plate (\*) is recommended.
  3. Install the Power Supply so that the air flow circulates around the Power Supply, as the Power Supply is designed to radiate heat by means of natural air flow.

### 300-W 5V, 12V Model

Front-mounting

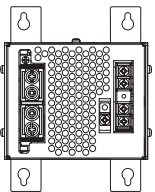

Bottom-mounting

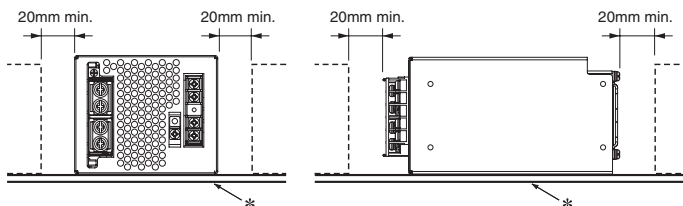

Side-mounting

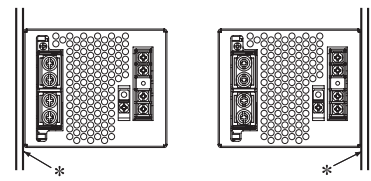

DIN Rail mounting

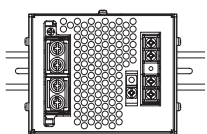

- Note:**
1. Improper mounting will interfere with heat dissipation and may occasionally result in deterioration or damage of internal parts. Use the standard mounting method only.
  2. When mounting the Power Supply, mounting it to a metal plate (\*) is recommended.
  3. Do not cover the air holes (provided at fan mounted side and the opposite side) to have enough air-cooling.

### 300-W 24V, 48V Model

Front-mounting

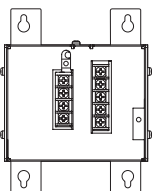

Bottom-mounting

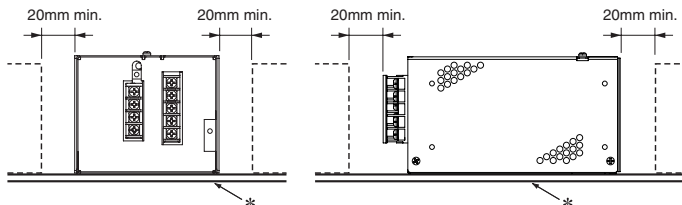

Side-mounting

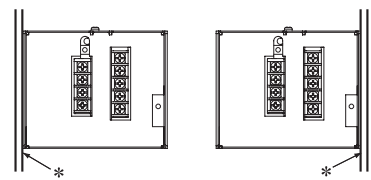

DIN Rail mounting

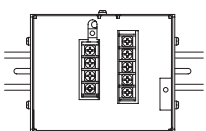

- Note:**
1. Improper mounting will interfere with heat dissipation and may occasionally result in deterioration or damage of internal parts. Use the standard mounting method only.
  2. When mounting the Power Supply, mounting it to a metal plate (\*) is recommended.
  3. Install the Power Supply so that the air flow circulates around the Power Supply, as the Power Supply is designed to radiate heat by means of natural air flow.



600-W Model

Front-mounting

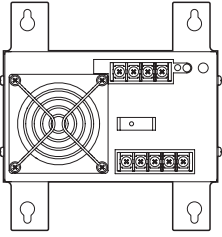

Bottom-mounting

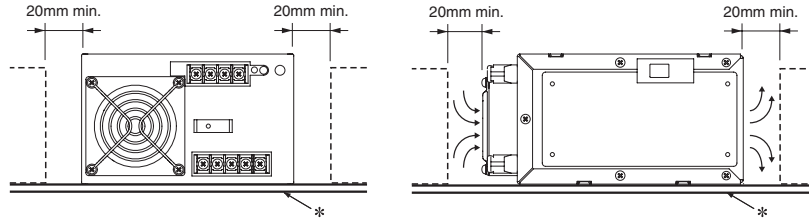

Side-mounting

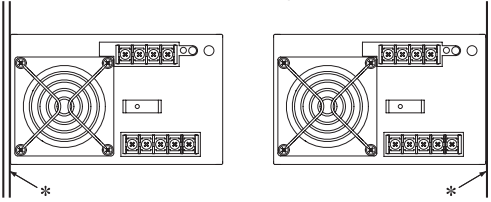

- Note: 1.** Improper mounting will interfere with heat dissipation and may occasionally result in deterioration or damage of internal parts. Use the standard mounting method only.
- 2.** When mounting the Power Supply, mounting it to a metal plate (\*) is recommended.
- 3.** Do not cover the air holes (provided at fan mounted side and the opposite side) to have enough air-cooling.

**Overload Protection**

The Power Supply is provided with an overload protection function that protects the power supply from possible damage by overcurrent. When the output current rises above 105% to 175% min. of the rated current, the protection function is triggered, decreasing the output voltage. When the output current falls within the rated range, the overload protection function is automatically cleared.

- Note:**
1. When a load is connected that has a built-in DC-DC converter, the overload protection may operate at startup and the power supply may not start.
  2. Internal parts may occasionally deteriorate or be damaged if a short-circuited or overcurrent state continues during operation.
  3. Internal parts may possibly deteriorate or be damaged if the Power Supply is used for applications with frequent inrush current or overloading at the load end. Do not use the Power Supply for such applications.

**(Reference value)**

**15-/35-/50-/100-/150-W (12-/24-/48-V) Models**

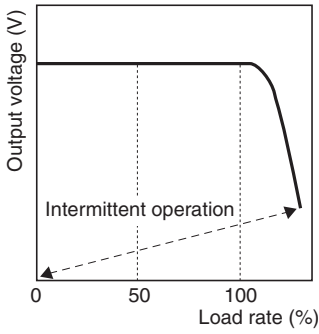

**300-W 5V, 12V/600-W Model**

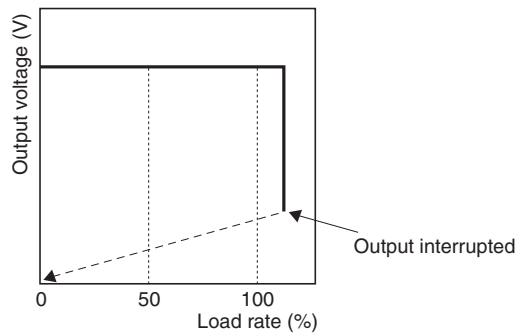

If an excessive current flows for 5 s or more, the output will be turned OFF and simultaneously the protection-ON alarm indicator will be lit. To reset the S8JX, turn OFF the power, leave the S8JX for at least three minutes, and then turn it ON again.

**150-W, 5-V Models**

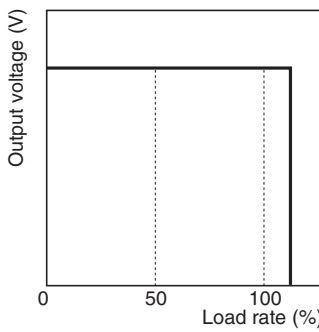

**300-W 24V, 48V Model**

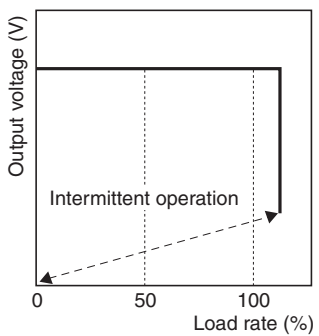

## Overvoltage Protection

### 15-/35-/50-/100-/150-W Models

Consider the possibility of an overvoltage and design the system so that the load will not be subjected to an excessive voltage even if the feedback circuit in the power supply fails. When an excessive voltage that is approximately 130% of the rated voltage or more is output, the output voltage is shut OFF, preventing damage to the load due to overvoltage. Reset the input power by turning it OFF for at least seven minutes and then turning it back ON again.

### 300-/600-W Models

Consider the possibility of an overvoltage and design the system so that the load will not be subjected to an excessive voltage even if the feedback circuit in the Power Supply fails. When an excessive voltage that is approximately 120% of the rated voltage or more is output, the output voltage is shut OFF, preventing damage to the load due to overvoltage (Except 300-W 24V, 48V models). Reset the input power by turning it OFF for at least three minute and then turning it back ON again.

#### (Reference value)

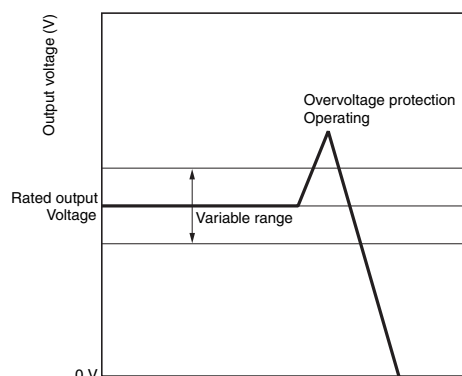

**Note:** Do not turn ON the power again until the cause of the overvoltage has been removed.

## Overheat Protection

### 300-W 5V, 12V/600-W Model

If the internal temperature rises excessively as a result of fan failure or any other reason, the overheat protection circuit will be triggered to shut OFF the output voltage and simultaneously the protection-ON alarm indicator will be lit. Reset the input power by turning it OFF for at least three minutes and then turning it back ON again.

## Inrush Current, Startup Time, Output Hold Time

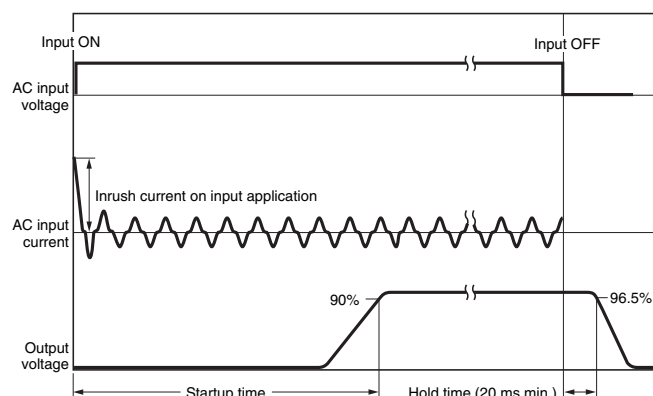

**Note:** A maximum startup time of 500 ms is required (650 ms for 300 W). Construct a system configuration that considers the startup time of other devices.

# S8JX

## Dimensions

(Unit: mm)

### Front-mounting Models

- S8JX-G015□□ (15 W)
- S8JX-G015□□C (15 W)
- S8JX-G035□□ (35 W)
- S8JX-G035□□C (35 W)

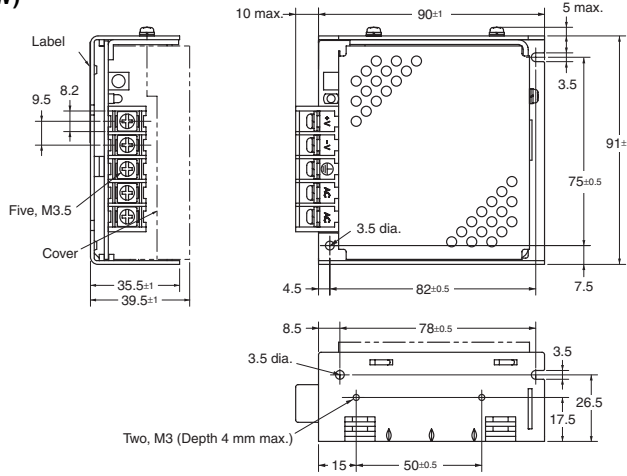

#### Panel mounting holes dimensions

	Surface screw mounting
Side Mounting	Two, M3 75±0.5 82±0.5
Bottom Mounting	Two, M3 78±0.5

- S8JX-G050□□ (50 W)
- S8JX-G050□□C (50 W)

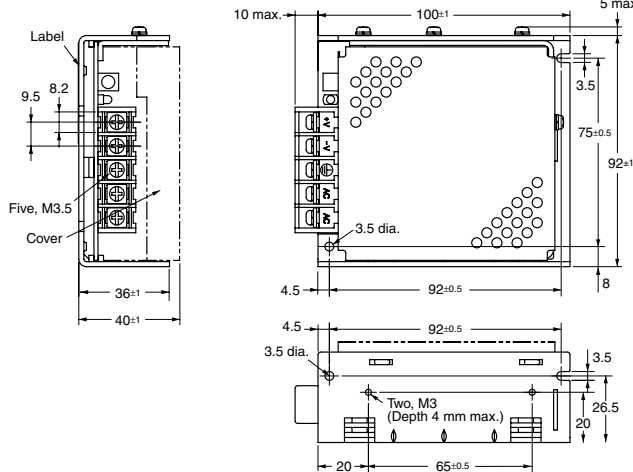

#### Panel mounting holes dimensions

	Surface screw mounting
Side Mounting	Two, M3 75±0.5 92±0.5
Bottom Mounting	Two, M3 92±0.5

- S8JX-G100□□ (100 W)
- S8JX-G100□□C (100 W)
- S8JX-G15024 (150 W)
- S8JX-G15024C (150 W)
- S8JX-G15048 (150 W)
- S8JX-G15048C (150 W)

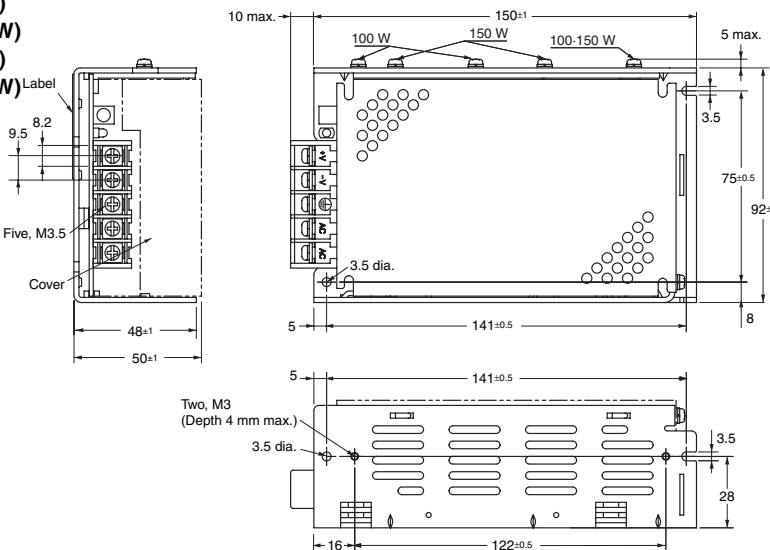

#### Panel mounting holes dimensions

	Surface screw mounting
Side Mounting	Two, M3 75±0.5 141±0.5
Bottom Mounting	Two, M3 141±0.5

S8JX-G

S8JX-P

Common Precautions

**S8JX-G15005 (150 W)**  
**S8JX-G15005C (150 W)**

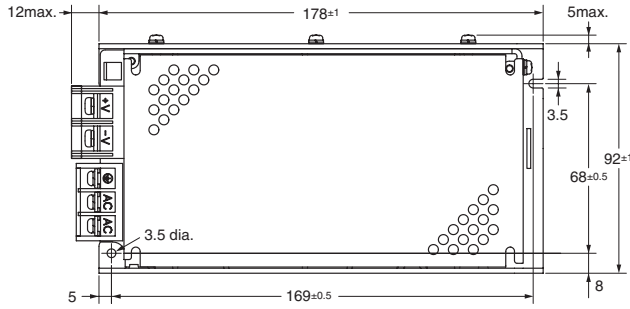
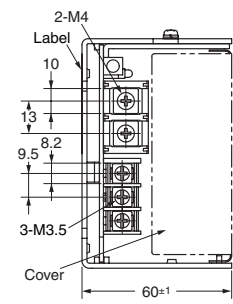

**Panel mounting holes dimensions**

Surface screw mounting	
<b>Side Mounting</b>	Two, M3 68±0.5 169±0.5
<b>Bottom Mounting</b>	Two, M3 169±0.5

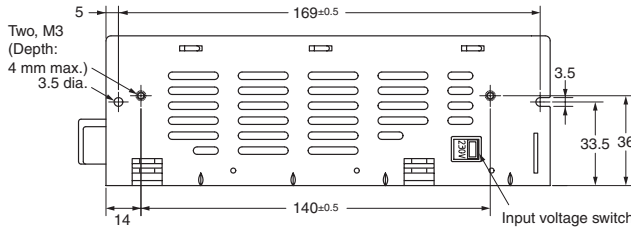

**S8JX-G15012 (150 W)**  
**S8JX-G15012C (150 W)**

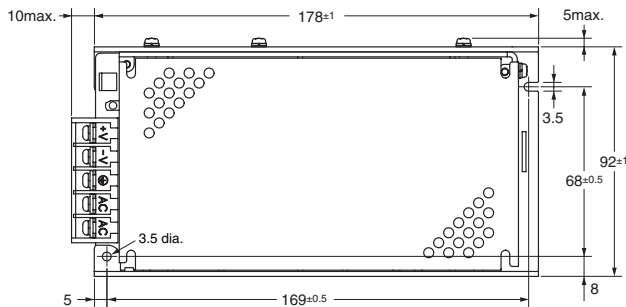
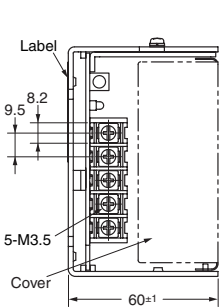

**Panel mounting holes dimensions**

Surface screw mounting	
<b>Side Mounting</b>	Two, M3 68±0.5 169±0.5
<b>Bottom Mounting</b>	Two, M3 169±0.5

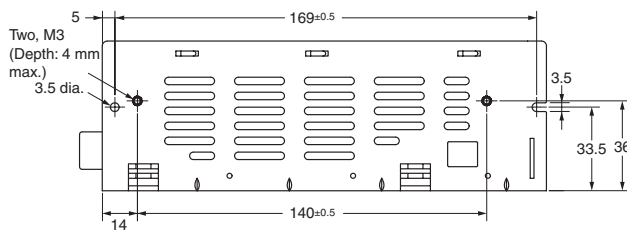

# S8JX

S8JX-G

S8JX-G30005C (300 W)  
S8JX-G30012C (300 W)

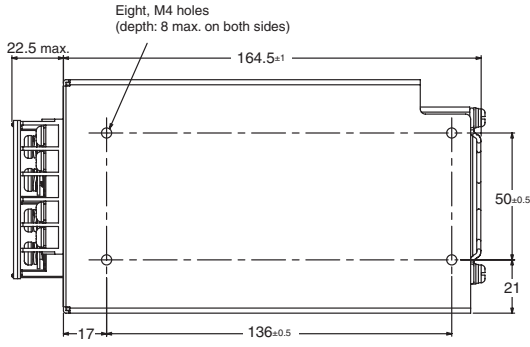
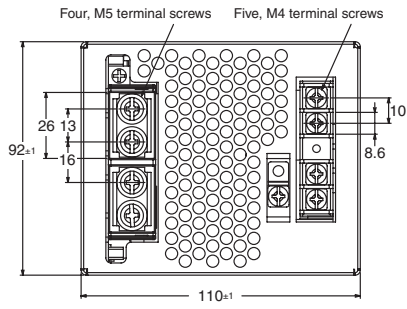

### Panel mounting holes dimensions

Surface screw mounting	
Side Mounting	Four, 4.5 dia. 50±0.5 136±0.5
	Four, 4.5 dia. 90±0.5 136±0.5

S8JX-P

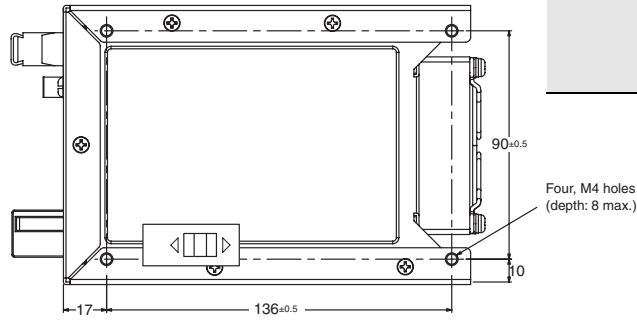

S8JX-G30024C (300 W)  
S8JX-G30048C (300 W)

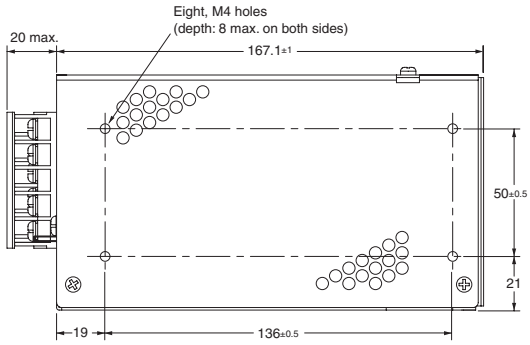
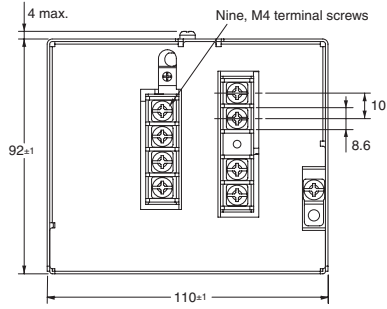

### Panel mounting holes dimensions

Surface screw mounting	
Side Mounting	Four, 4.5 dia. 50±0.5 136±0.5
	Four, 4.5 dia. 90±0.5 136±0.5

Common Precautions

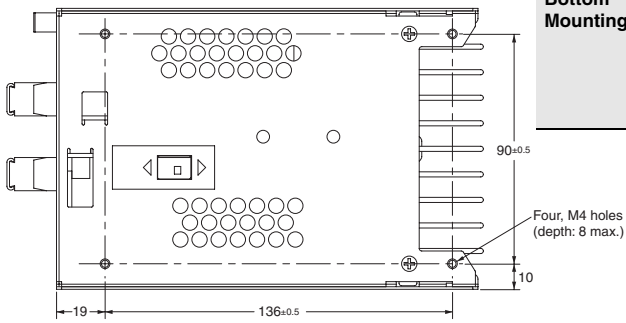

S8JX-G60005 (600 W)  
S8JX-G60012 (600 W)

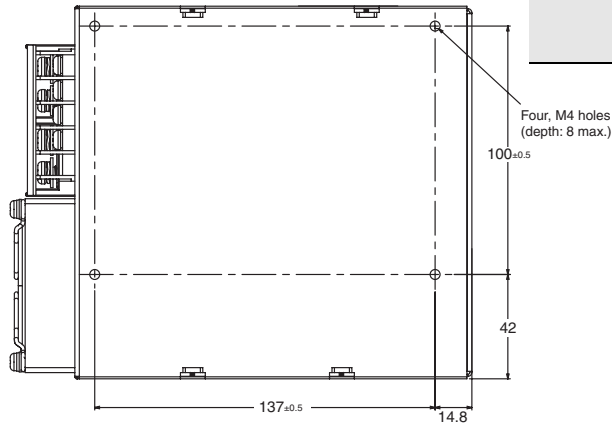
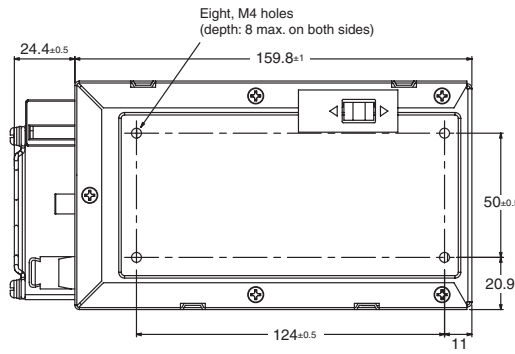
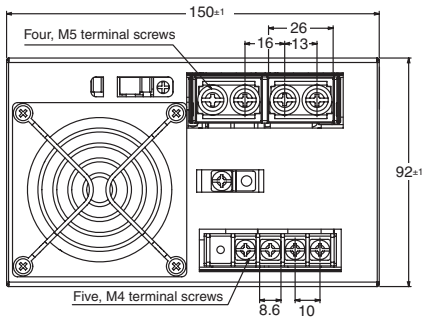

Panel mounting holes dimensions

	Surface screw mounting
Side Mounting	
Bottom Mounting	

S8JX-G

S8JX-P

S8JX-G60024C (600 W)  
S8JX-G60048C (600 W)

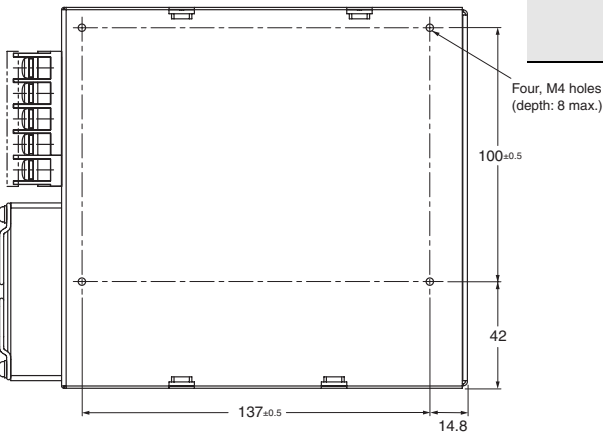
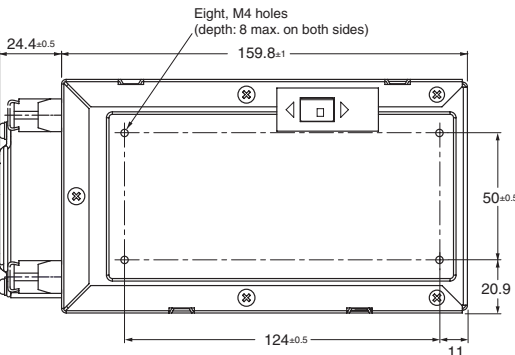
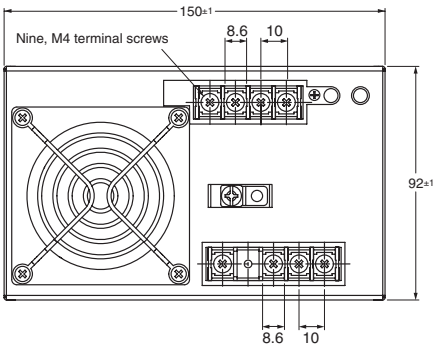

Panel mounting holes dimensions

	Surface screw mounting
Side Mounting	
Bottom Mounting	

Common Precautions



**Mounting Bracket Provided with Front-mounting Power Supplies (A)**

15-/35-/50-/100-/150-W Models

**S82Y-J00F Front-mounting Bracket**

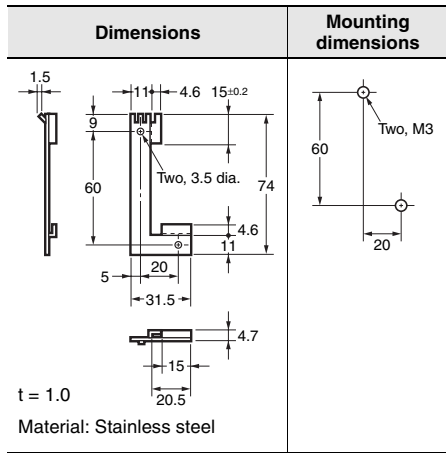

**Front-mounting Method**

Temporarily attach the enclosed mounting bracket as shown in the illustration on the right, hook the holes (parts a) in the Power Supply on hooks on the mounting bracket (parts b), and secure the Power Supply with two mounting screws.

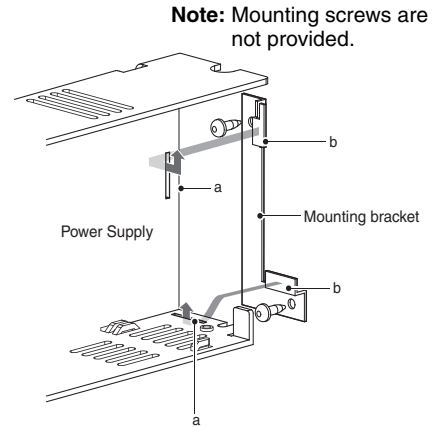

300-/600-W Models

**Front-mounting Bracket (S82Y-J30F)**

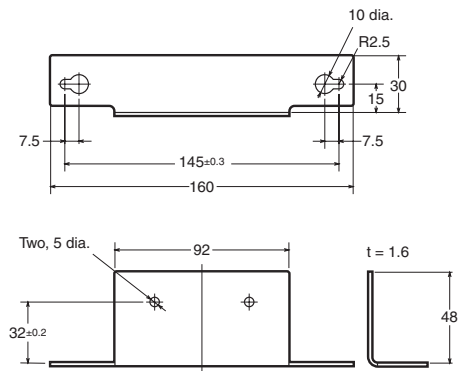

**Note:** Mounting Brackets are provided in a set, one for the right side and one for the left side.

**Dimensions with Mounting Brackets**

**300-W Model**

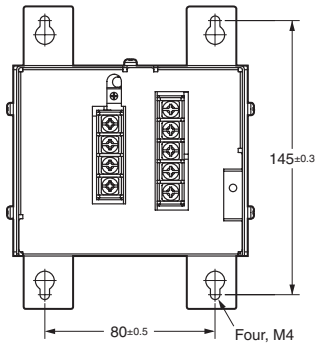

**Attaching the Mounting Brackets**

**300-W Model**

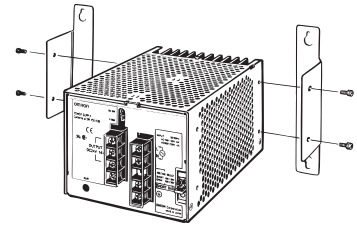

**Note:** To provide ventilation space, the body will shift forward by 21.6 mm from the mounting surface.

**600-W Model**

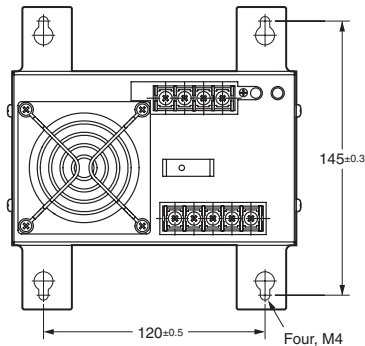

**600-W Model**

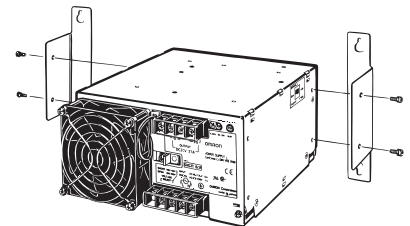

**Note:** To provide ventilation space, the body will shift forward by 23.6 mm from the mounting surface.

**Separately purchasable mounting brackets** (Please ask your dealer for details of delivery.)

**For 30-W/50-W/100-W/150-W/300-W/600-W models (separately purchasable)**

**Bracket for changeover from S82J-series**

The mounting-hole pitch of mounting brackets A - I below is identical to that of our product S82J. These brackets can be used for switchover with the S82J-series.

Models compatible with the S82J-series	Mounting Orientation	Products names	Model
50-W models	Underside mounting	Mounting bracket A (For S8JX-G-series 50-W models)	S82Y-JX05B
100-W 24 V models		Mounting bracket B (For S8JX-G-series 100-W 24 V models)	S82Y-JX10B
100-W 5 V, 12 V, 150-W 24 V models		Mounting bracket C (For S8JX-G-series 100-W 5 V, 12 V, 150 W models)	S82Y-JX15B
100-W 5 V, 12 V, 150-W 24 V models	Front mounting	Mounting bracket D (For S8JX-G-series 100-W 5 V, 12 V, 150 W models)	S82Y-JX15F
25-W models	Underside mounting	Mounting bracket E (For S8JX-G-series 30-W models)	S82Y-JX03B
300-W models	Underside mounting	Mounting bracket F (For S8JX-G-series 300-W models)	S82Y-JX30B
	Front mounting	Mounting bracket G (For S8JX-G-series 300-W models)	S82Y-JX30F
600-W models	Underside mounting	Mounting bracket H (For S8JX-G-series 600-W models)	S82Y-JX60B
	Front mounting	Mounting bracket I (For S8JX-G-series 600-W models)	S82Y-JX60F

**Note:** Mounting brackets (A, B, C, D, E, F, G, H, I) are compatible with S82J mounting holes.

**Mounting Bracket A**  
S82Y-JX05B

Method of Mounting

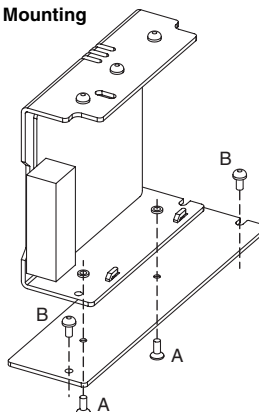
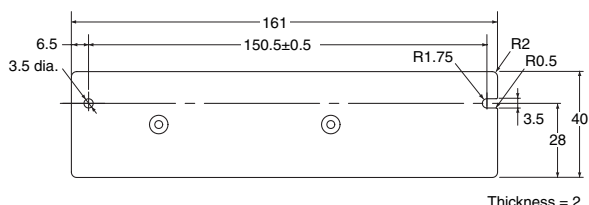

**Screws used**  
**A: Accessories (2 locations)**  
 Be sure to use the accessory screws.  
 Mounting screw tightening torque  
 (recommended): 0.49 N · m  
**B: M3 (2 locations)**

**Mounting Bracket B**  
S82Y-JX10B

Method of Mounting

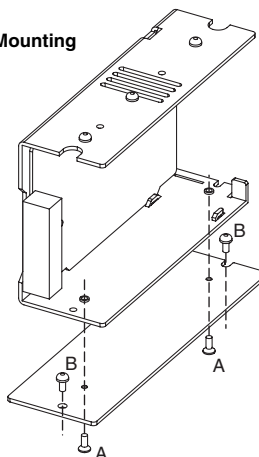
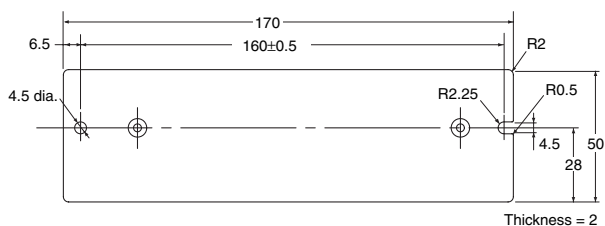

**Screws used**  
**A: Accessories (2 locations)**  
 Be sure to use the accessory screws.  
 Mounting screw tightening torque  
 (recommended): 0.49 N · m  
**B: M4 (2 locations)**

**Mounting Bracket C**  
S82Y-JX15B

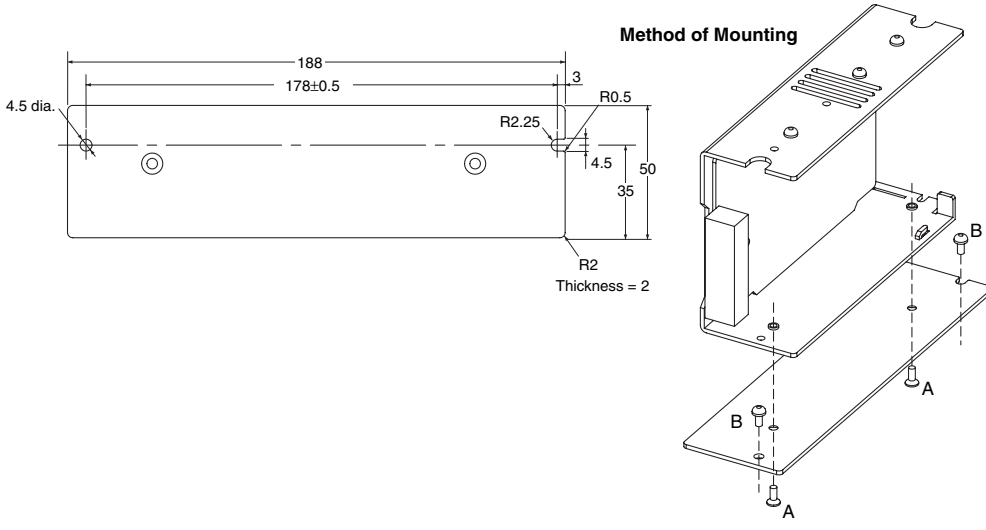

**Screws used**  
**A: Accessories (2 locations)**  
 Be sure to use the accessory screws.  
 Mounting screw tightening torque (recommended): 0.49 N · m  
**B: M4 (2 locations)**

**Mounting Bracket D**  
S82Y-JX15F

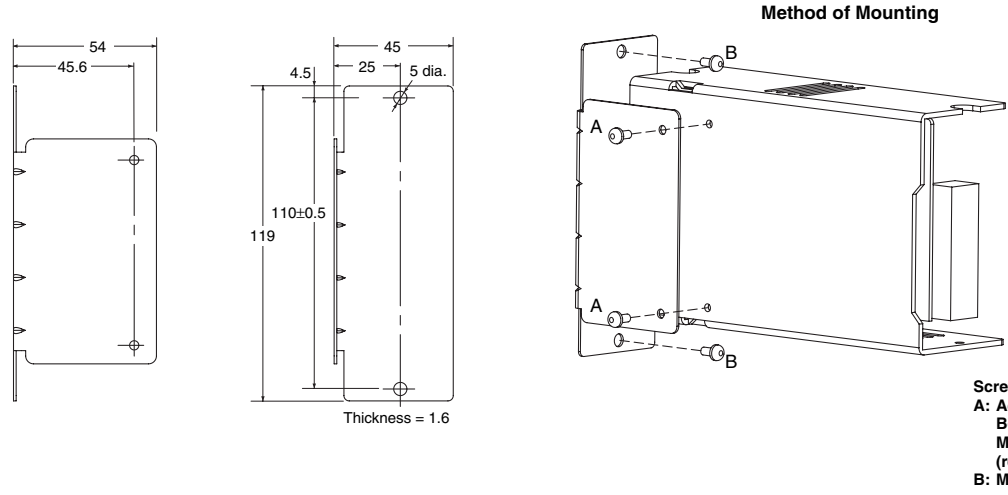

**Screws used**  
**A: Accessories (2 locations)**  
 Be sure to use the accessory screws  
 Mounting screw tightening torque (recommended): 0.49 N · m  
**B: M4 (2 locations)**

**Mounting Bracket E**  
S82Y-JX03B

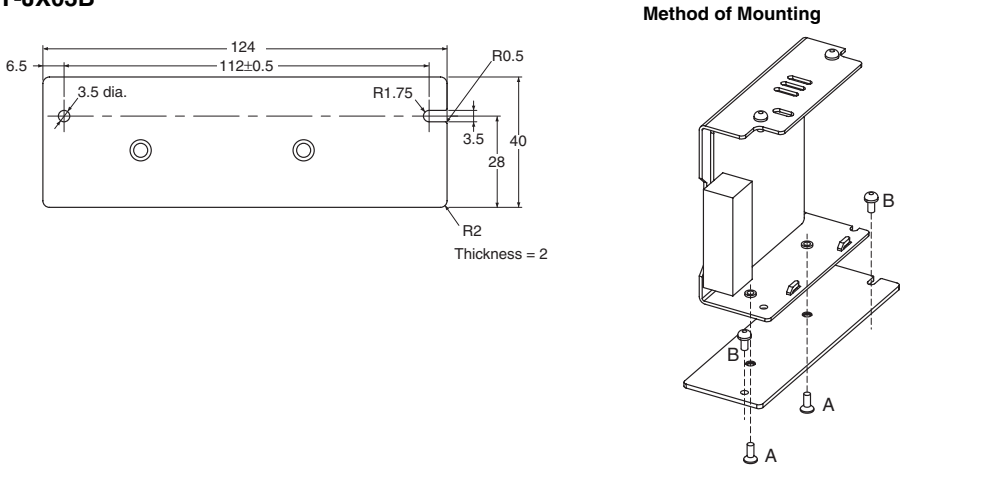

**Screws used**  
**A: Accessories (2 locations)**  
 Be sure to use the accessory screws.  
 Mounting screw tightening torque (recommended): 0.49 N · m  
**B: M3 (2 locations)**

**Mounting Bracket F**  
S82Y-JX30B

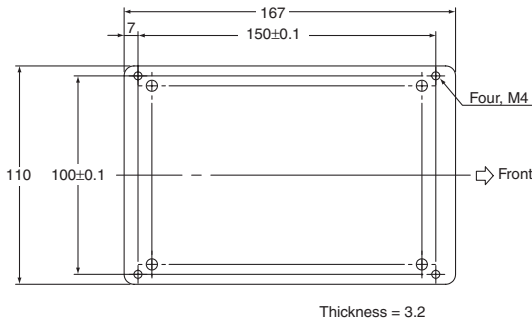

**Method of Mounting**

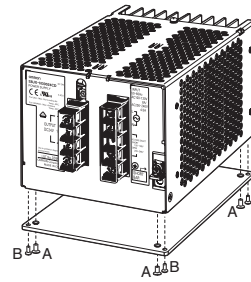

**Screws used**  
**A: Accessories (4 locations)**  
 Be sure to use the accessory screws.  
**B: M4 (4 locations)**  
 Screws of a length that will not project beyond the fixture (thickness: 3.2 mm) should be selected.

**Mounting Bracket G**  
S82Y-JX30F

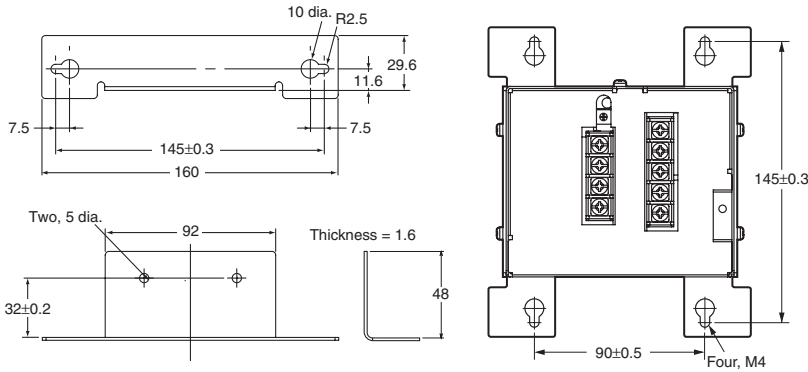

**Method of Mounting**

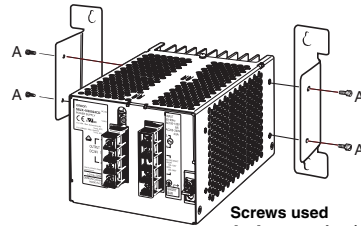

**Screws used**  
**A: Accessories (4 locations)**  
 Be sure to use the accessory screws.

**Note:** For ventilation of the back surface, the body should be placed 21.6 mm in front of the mounting side.

**Mounting Bracket H**  
S82Y-JX60B

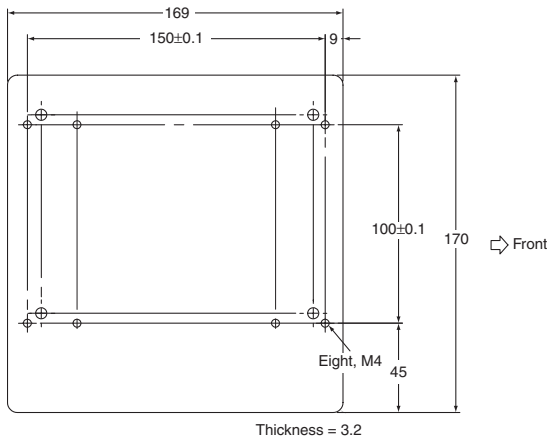

**Method of Mounting**

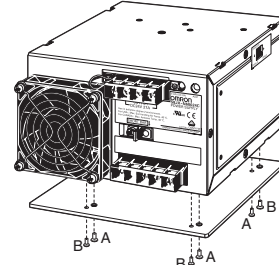

**Screws used**  
**A: Accessories (4 locations)**  
 Be sure to use the accessory screws.  
**B: M4 (4 locations)**  
 Screws of a length that will not project beyond the fixture (thickness: 3.2 mm) should be selected. (Although there are 8 holes in the bracket body, only 4 of these are used.)

**Mounting Bracket I**  
S82Y-JX60F

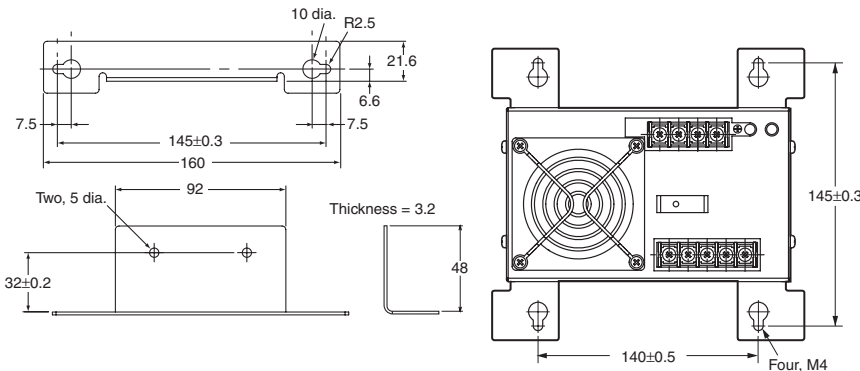

**Method of Mounting**

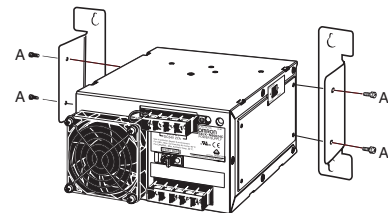

**Screws used**  
**A: Accessories (4 locations)**  
 Be sure to use the accessory screws.

**Note:** For ventilation of the back surface, the body should be placed 23.6 mm in front of the mounting side.

DIN Rail-mounting Models

S8JX-G

- S8JX-G015□□D (15 W)
- S8JX-G015□□CD (15 W)
- S8JX-G035□□D (35 W)
- S8JX-G035□□CD (35 W)

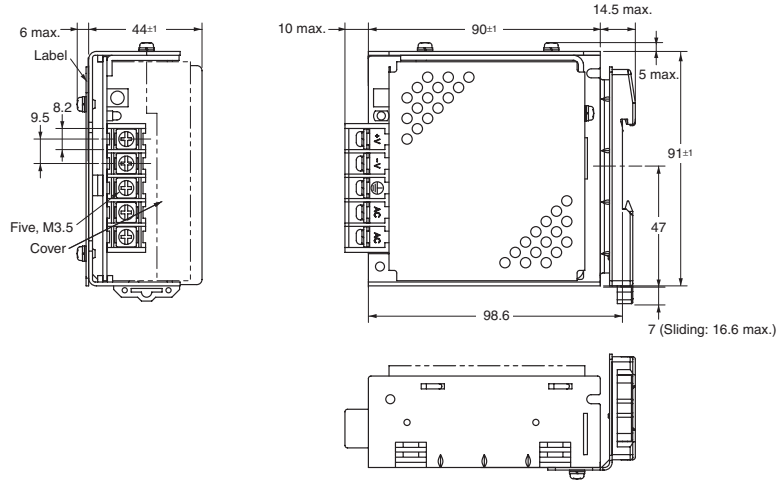
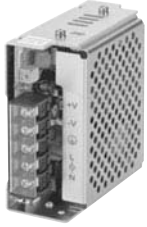

S8JX-P

- S8JX-G050□□D (50 W)
- S8JX-G050□□CD (50 W)

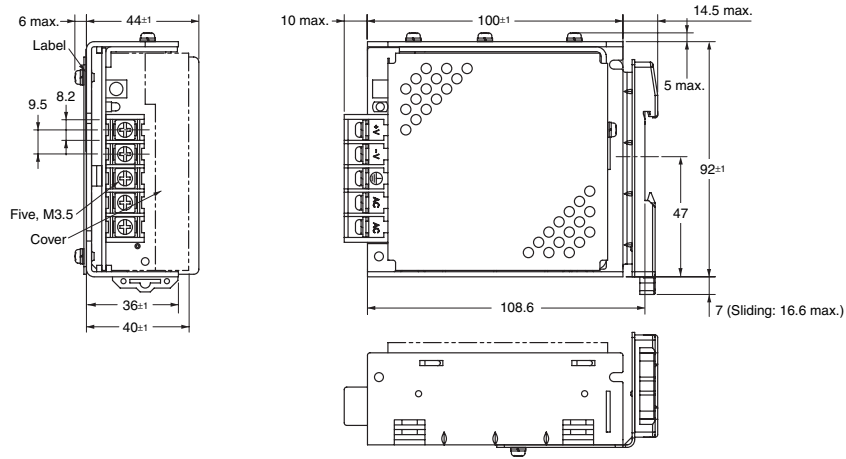

Common Precautions

- S8JX-G100□□D (100 W)
- S8JX-G100□□CD (100 W)
- S8JX-G15024D (150 W)
- S8JX-G15024CD (150 W)
- S8JX-G15048D (150 W)
- S8JX-G15048CD (150 W)

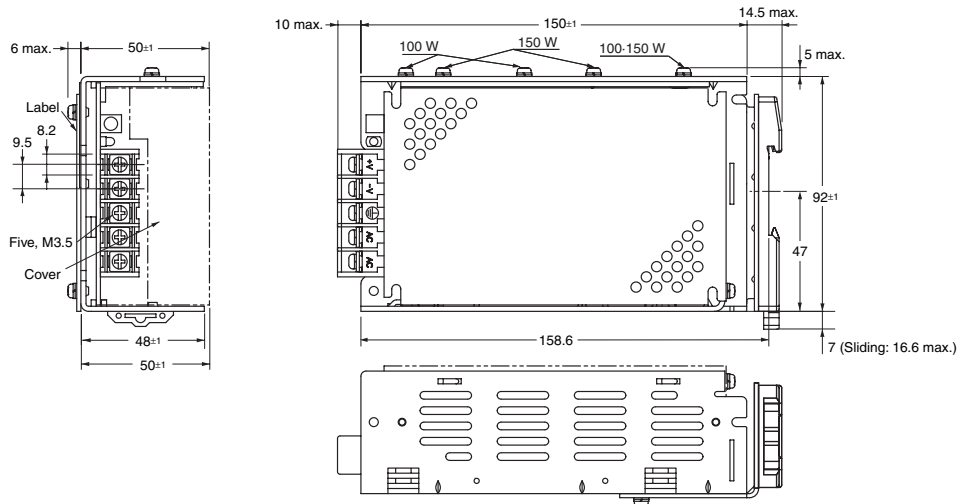

S8JX-G15005D (150 W)  
S8JX-G15005CD (150 W)

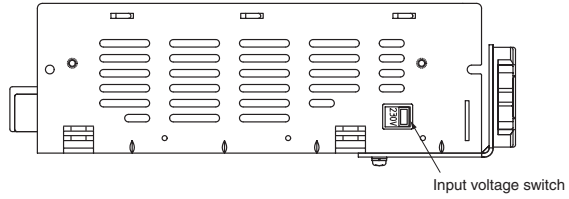
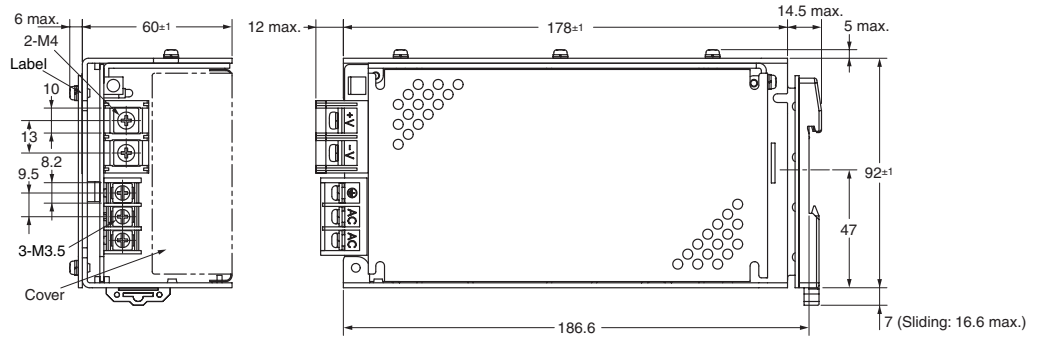

S8JX-G15012D (150 W)  
S8JX-G15012CD (150 W)

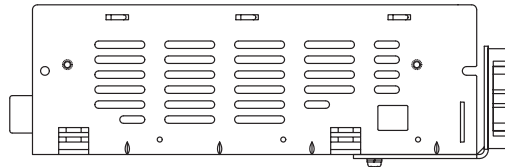
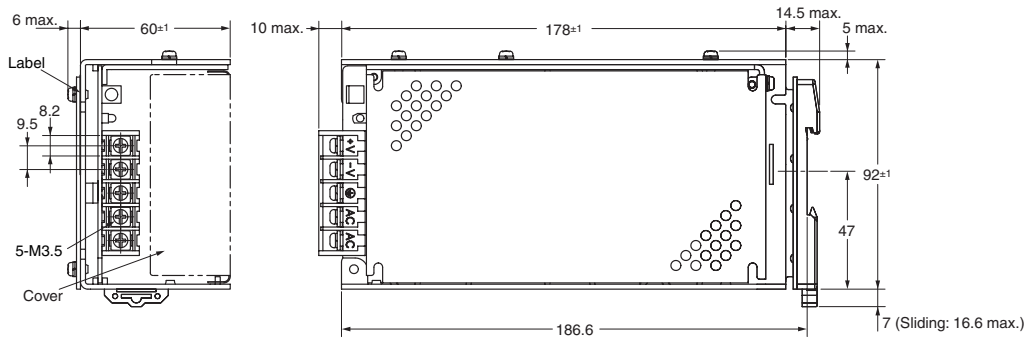

S8JX-G

S8JX-P

Common Precautions

# S8JX

S8JX-G

S8JX-G30005CD (300W)  
S8JX-G30012CD (300W)

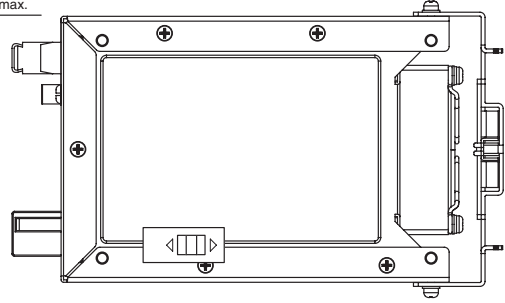
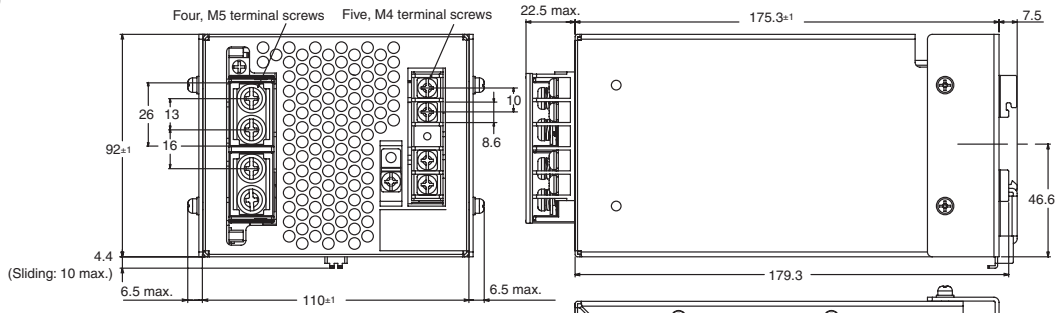

**Note:** Use a metal DIN Rail when mounting a 300-W model to a DIN Rail.

S8JX-P

S8JX-G30024CD (300 W)  
S8JX-G30048CD (300 W)

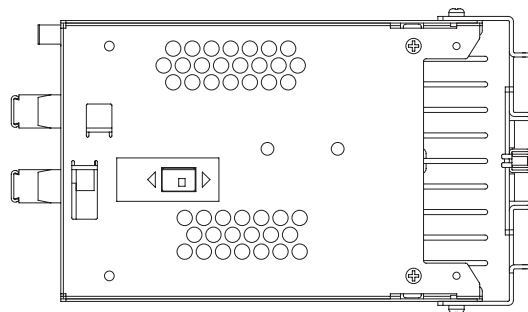
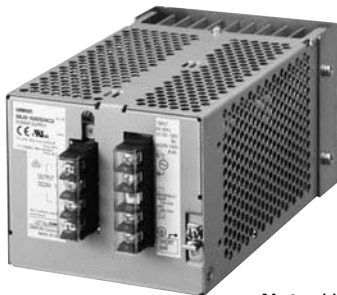
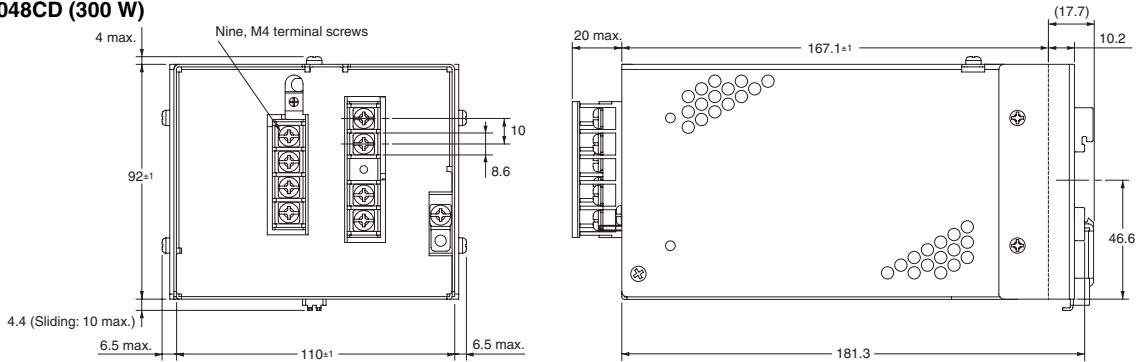

**Note:** Use a metal DIN Rail when mounting a 300-W model to a DIN Rail.

Common Precautions



## DIN Rail (Order Separately)

### Mounting Rail (Material: Aluminum)

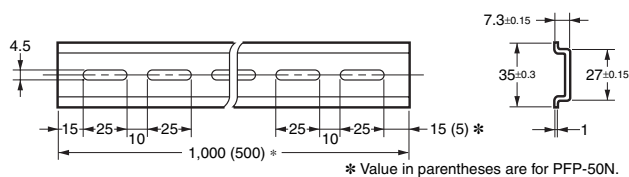
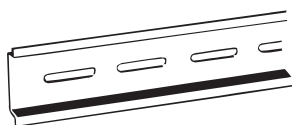

Model
PFP-100N
PFP-50N

### Mounting Rail (Material: Aluminum)

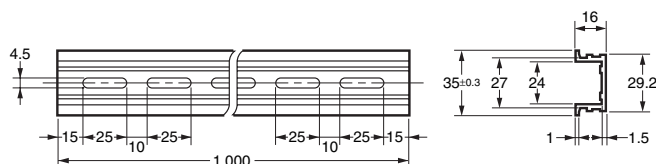
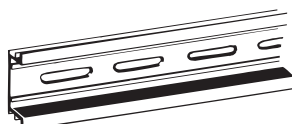

Model
PFP-100N2

### End Plate

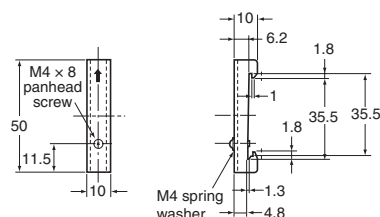
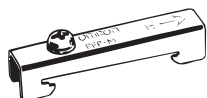

Model
PFP-M

- Note:**
1. If there is a possibility that the Unit will be subject to vibration or shock, use a steel DIN Rail. Otherwise, metallic filings may result from aluminum abrasion.
  2. If the Unit may be subjected to sliding to either side, attach an End Plate (model PFP-M) on each side of the Unit.

## Terminal Cover (Order Separately)

Terminal Cover model	Applicable Power Supply and applicable location
S82Y-JX-C4P	S8JX-G-300W, 24-V or 48-V output
	S8JX-G-600W, 24-V or 48-V output
S82Y-JX-C5P	S8JX-G-300W, input
	S8JX-G-600W, input
S82Y-JTC1	S8JX-G-15W
	S8JX-G-30W
	S8JX-G-50W
	S8JX-G-100W
	S8JX-G-150W, 12-V, 24-V or 48-V model

## Replacement Fan (sold separately)

Model
S82Y-JXFAN



## Model Number Structure

### Model Number Legend

**Note:** Not all combinations are possible. Refer to *List of Models in Ordering Information* on page 36.

#### 50-/100-/150-W Models

S8JX-P□□□□□□  
                   1    2    3    4

#### 1. Power Ratings

050: 50 W  
 100: 100 W  
 150: 150 W

#### 2. Output Voltage

05: 5 V  
 12: 12 V  
 24: 24 V  
 48: 48 V

#### 3. Configuration (50/100/150 W model)

None: Open type  
 C: Covered

#### 4. Configuration/mounting

None: Front-mounting  
 D: DIN Rail-mounting

#### 300-/600-W Models

S8JX-P□□□□□□  
                   1    2    3

#### 1. Power Ratings

300: 300 W  
 600: 600 W

#### 2. Output Voltage

05: 5V  
 12: 12 V  
 24: 24 V  
 48: 48 V

#### 3. Configuration/mounting (covered type)

C: Front-mounting  
 CD: DIN Rail-mounting  
 N: Without mounting bracket

**Note:** Estimates can be provided for coatings and other specifications that are not given in the datasheet. Ask your OMRON representative for details.

# S8JX

## Ordering Information

### List of Models

Note: For details on normal stock models, contact your nearest OMRON representative.

#### DIN Rail-mounting \*



Configuration	Input voltage	Power ratings	Output voltage (VDC)	Output current	Built-in fan	Model
Covered Power Supplies	100 to 240 VAC (free) (80 to 370 VDC *)	50 W	5 V	10 A	No	S8JX-P05005CD
			12 V	4.2 A		S8JX-P05012CD
			24 V	2.1 A		S8JX-P05024CD
			48 V	1.1 A		S8JX-P05048CD
		100 W	5 V	20 A		S8JX-P10005CD
			12 V	8.5 A		S8JX-P10012CD
			24 V	4.5 A		S8JX-P10024CD
			48 V	2.1 A		S8JX-P10048CD
		150 W	5 V	30 A		S8JX-P15005CD
			12 V	13 A		S8JX-P15012CD
			24 V	6.5 A		S8JX-P15024CD
			48 V	3.3 A		S8JX-P15048CD
		300 W	5 V	60 A	Yes	S8JX-P30005CD
			12 V	27 A		S8JX-P30012CD
			24 V	14 A peak current 16.5 A (200 VAC)		S8JX-P30024CD
			48 V	7 A		S8JX-P30048CD
		600 W	5 V	120 A	Yes	S8JX-P60005CD
			12 V	53 A		S8JX-P60012CD
			24 V	27 A peak current 31 A (200 VAC)		S8JX-P60024CD
			48 V	13 A		S8JX-P60048CD

\* The range for compliance with EC Directives and safety standards (UL, EN, etc.) is 100 to 240 VAC (85 to 264 VAC).

#### DIN Rail-mounting \*



Configuration	Input voltage	Power ratings	Output voltage (VDC)	Output current	Built-in fan	Model
Open type Power Supplies	100 to 240 VAC (free) (80 to 370 VDC *)	50 W	5 V	10 A	No	S8JX-P05005D
			12 V	4.2 A		S8JX-P05012D
			24 V	2.1 A		S8JX-P05024D
			48 V	1.1 A		S8JX-P05048D
		100 W	5 V	20 A		S8JX-P10005D
			12 V	8.5 A		S8JX-P10012D
			24 V	4.5 A		S8JX-P10024D
			48 V	2.1 A		S8JX-P10048D
		150 W	5 V	30 A		S8JX-P15005D
			12 V	13 A		S8JX-P15012D
			24 V	6.5 A		S8JX-P15024D
			48 V	3.3 A		S8JX-P15048D

\* The range for compliance with EC Directives and safety standards (UL, EN, etc.) is 100 to 240 VAC (85 to 264 VAC).

S8JX-G

S8JX-P

Common Precautions

## Front-mounting \*



Configuration	Input voltage	Power ratings	Output voltage (VDC)	Output current	Built-in fan	Front-mounting bracket	Model				
Covered Power Supplies	100 to 240 VAC (free) (80 to 370 VDC *)	50 W	5 V	10 A	No	Provided	S8JX-P05005C				
			12 V	4.2 A			S8JX-P05012C				
			24 V	2.1 A			S8JX-P05024C				
			48 V	1.1 A			S8JX-P05048C				
		100 W	5 V	20 A			Yes	No	S8JX-P10005C		
			12 V	8.5 A					S8JX-P10012C		
			24 V	4.5 A					S8JX-P10024C		
			48 V	2.1 A					S8JX-P10048C		
		150 W	5 V	30 A					Yes	No	S8JX-P15005C
			12 V	13 A							S8JX-P15012C
			24 V	6.5 A							S8JX-P15024C
			48 V	3.3 A							S8JX-P15048C
		300 W	5 V	60 A	Yes	No					S8JX-P30005C
			12 V	27 A							S8JX-P30012C
			24 V	14 A peak current 16.5 A (200 VAC)							S8JX-P30024C
			48 V	7 A							S8JX-P30048C
		600 W	5 V	120 A			Yes	No			S8JX-P60005C
			12 V	53 A							S8JX-P60012C
			24 V	27 A peak current 31 A (200 VAC)							S8JX-P60024C
			48 V	13 A							S8JX-P60048C
		300 W	5 V	60 A					Yes	No	S8JX-P30005N
			12 V	27 A							S8JX-P30012N
			24 V	14 A peak current 16.5 A (200 VAC)							S8JX-P30024N
			48 V	7 A							S8JX-P30048N
600 W	5 V	120 A	Yes	No	S8JX-P60005N						
	12 V	53 A			S8JX-P60012N						
	24 V	27 A peak current 31 A (200 VAC)			S8JX-P60024N						
	48 V	13 A			S8JX-P60048N						

\* The range for compliance with EC Directives and safety standards (UL, EN, etc.) is 100 to 240 VAC (85 to 264 VAC).

## Front-mounting \*



Configuration	Input voltage	Power ratings	Output voltage (VDC)	Output current	Built-in fan	Front-mounting bracket	Model				
Open type Power Supplies	100 to 240 VAC (free) (80 to 370 VDC *)	50 W	5 V	10 A	No	Provided	S8JX-P05005				
			12 V	4.2 A			S8JX-P05012				
			24 V	2.1 A			S8JX-P05024				
			48 V	1.1 A			S8JX-P05048				
		100 W	5 V	20 A			No	Provided	S8JX-P10005		
			12 V	8.5 A					S8JX-P10012		
			24 V	4.5 A					S8JX-P10024		
			48 V	2.1 A					S8JX-P10048		
		150 W	5 V	30 A					No	Provided	S8JX-P15005
			12 V	13 A							S8JX-P15012
			24 V	6.5 A							S8JX-P15024
			48 V	3.3 A							S8JX-P15048

\* The range for compliance with EC Directives and safety standards (UL, EN, etc.) is 100 to 240 VAC (85 to 264 VAC).

Ratings, Characteristics, and Functions

S8JX-G

S8JX-P

Common Precautions

Item	Input specification		100 to 240 V input			
	Power ratings *1		50 W	100 W	150 W	
Efficiency	5-V Models		73% min.	78% min.	79% min.	
	12-V Models		76% min.	78% min.	78% min.	
	24-V Models		77% min.	81% min.	81% min.	
	48-V Models		80% min.	81% min.	82% min.	
Input	Voltage *2		100 to 240 VAC (allowable range: 85 to 264 VAC) 80 to 370 VDC *9			
	Frequency *2		50/60 Hz (47 to 63 Hz)			
	Current *3	100 V input	0.75 A max.	1.4 A max.	2.1 A max.	
		200 V input	0.4 A max.	0.75 A max.	1.1 A max.	
	Power factor		0.9 min.			
	Harmonic current emissions		Conforms to EN61000-3-2			
	Leakage current *3	100 V input	0.5 mA max.			
		200 V input	1 mA max.			
	Inrush current (for a cold start at 25°C) *3	100 V input	17.5 A max.			
		200 V input	35 A max.			
Noise filter		Yes				
Output *4	Voltage adjustment range *5		-10% to 15% (with V. ADJ) (48-V models: ±10%)			
	Ripple *3		2% (p-p) max. This shall be 3% (p-p) or less when the ambient temperature is less than 0°C (for only 5 V type).			
	Input variation influence		0.4% max. with AC input voltage			
	Load variation influence		0.8% max. (0 to 100% load, rated input voltage)			
	Temperature variation influence		0.05%/°C max. (at rated input and output)			
	Startup time		1,000 ms max.			
	Hold time *3		20 ms min.			
Additional functions	Overload protection *6		105% to 160% of rated load current, voltage drop, intermittent, automatic reset	105% to 160% of rated load current, voltage drop, automatic reset		
	Overvoltage protection *7		Yes			
	Overheat protection		No			
	Parallel operation		No (However, backup operation is possible; external diodes required.)			
	Series operation		Yes (For up to two Power Supplies; external diodes required.)			
	Alarm indicator		No			
Other	Ambient operating temperature		Refer to the derating curve in <i>Engineering Data</i> on page 44 (with no icing or condensation).			
	Storage temperature		-25 to 75°C (with no icing or condensation)			
	Ambient operating humidity		25% to 85% (Storage humidity: 25% to 90%)			
	Dielectric strength		3.0 kVAC for 1 min. (between all inputs and outputs; detection current: 20 mA) 2.0 kVAC for 1 min. (between all inputs and PE terminals; detection current: 20 mA) 1.0 kVAC for 1 min. (between all outputs and PE terminals; detection current: 20 mA)			
	Insulation resistance		100 MΩ min. (between all outputs and all inputs/PE terminals) at 500 VDC			
	Vibration resistance		10 to 55 Hz, 0.375-mm single amplitude for 2 h each in X, Y, and Z directions			
	Shock resistance		150 m/s <sup>2</sup> , 3 times each in ±X, ±Y, ±Z directions			
	Output indicator		Yes (Color: Green)			
	EMI	Conducted Emissions		Conforms to EN 55011 Group 1 Class B and based on FCC Class B *9		
		Radiated Emissions		Conforms to EN 55011 Group 1 Class B *9		
	EMS	Electrostatic Discharge		Conforms to EN61000-4-2		
		Radiated Electromagnetic Field		Conforms to EN61000-4-3		
		Electrical Fast Transient/Burst		Conforms to EN61000-4-4		
		Surge		Conforms to EN61000-4-5		
		Conducted Disturbance		Conforms to EN61000-4-6		
Voltage Dips/Short Interruptions		Conforms to EN61000-4-11				
Approved standards *9		UL Listed: UL 508 (Listing), UL UR: UL 60950-1 (Recognition) cUL Listed: CSA C22.2 No.107.1 cUR: CSA C22.2 No. 60950-1 EN/VDE: EN50178 (= VDE 0160) Over voltage category III, EN 60950-1 (= VDE 0805 Teil 1) (Terminal block: Based on DIN 50274 (VDE 0660-514))				
SEMI		SEMI F47-0706 (200-VAC input)				
Weight *8		370 g max.	550 g max.	590 g max.		

- \*1. When a load is connected that has a built-in DC-DC converter, the overload protection may operate at startup and the Power Supply may not start. Refer to *Overload Protection on page 46*.
- \*2. Do not use an Inverter output for the Power Supply. Inverters with an output frequency of 50/60 Hz are available, but the rise in the internal temperature of the Power Supply may result in ignition or burning.
- \*3. Rated input voltage: 100 or 200 VAC at 100% load.
- \*4. Output characteristics: Specified at power supply output terminals.
- \*5. If the output voltage adjuster (V. ADJ) is turned, the voltage will increase by more than the allowable voltage range. When adjusting the output voltage, confirm the actual output voltage from the Power Supply and be sure that load is not damaged.
- \*6. For details, refer to *Overload Protection on page 46*.
- \*7. To reset the protection, turn OFF the input power for three minutes or longer and then turn it back ON.
- \*8. The weight indicated is for Front-mounting, Open-frame Power Supply.
- \*9. The range for compliance with EC Directives and safety standards (UL, EN, etc.) is 100 to 240 VAC (85 to 264 VAC).

Item	Input specification		100 to 240 V input		
	Power ratings *1		300 W	600 W	
Efficiency		24V models	79% min.	78% min.	
Input	Voltage *2		100 to 240 VAC (allowable range: 85 to 264 VAC) 80 to 370 VDC *8		
	Frequency *2		50/60 Hz (47 to 63 Hz)		
	Current *3	100 V input	4.5 A max.	8.7 A max.	
		200 V input	2.2 A max.	4.3 A max.	
	Power factor		0.9 min.		
	Harmonic current emissions		Conforms to EN61000-3-2		
	Leakage current *3	100 V input	0.5 mA max.		
		200 V input	1 mA max.		
Inrush current (for a cold start at 25°C) *3	100 V input	17.5 A max.			
	200 V input	35 A max.			
Noise filter		Yes			
Output *4	Voltage adjustment range *5		-10% to 15% (with V. ADJ)		
	Ripple *3		2% (p-p) max.		
	Input variation influence		0.4% max.		
	Load variation influence		0.8% max. (0 to 100% load, rated input voltage)		
	Temperature variation influence		0.05%/°C max.		
	Startup time		1,000 ms max.		
	Hold time *3		20 ms min.		
Additional functions	Overload protection *6		105% to 160% of rated load current, voltage drop, intermittent, automatic reset.		
	Overvoltage protection *7		Yes		
	Overheat protection		Yes		
	Parallel operation		Yes (up to 5 Power Supplies)		
	Series operation		Yes (For up to two Power Supplies; external diodes required.)		
	Remote sensing		Supported		
	Remote control		Supported		
	Alarm detection indication		Yes (color: red)		
Alarm output		Provided, open-collector output, 30 VDC max, 50 mA max.			
Other	Ambient operating temperature		Refer to the derating curve in <i>Engineering Data</i> on page 44 (with no icing or condensation).		
	Storage temperature		-25 to 75°C (with no icing or condensation)		
	Ambient operating humidity		25% to 85% (Storage humidity: 25% to 90%)		
	Dielectric strength		3.0 kVAC for 1 min. (between all inputs and outputs; detection current: 20 mA) 2.0 kVAC for 1 min. (between all inputs and PE terminals; detection current: 20 mA) 1.0 kVAC for 1 min. (between all outputs and PE terminals; detection current: 100 mA) 100 VAC for 1 min. (between all outputs and RC terminals; detection current: 100 mA) 500 VAC for 1 min. (between all outputs and ALM terminals; detection current: 20 mA)		
	Insulation resistance		100 MΩ min. (between all outputs and all inputs/PE terminals) at 500 VDC		
	Vibration resistance		10 to 55 Hz, 0.375-mm single amplitude for 2 h each in X, Y, and Z directions		
	Shock resistance		150 m/s <sup>2</sup> , 3 times each in ±X, ±Y, ±Z directions *11		
	Output indicator		Yes (Color: Green)		
	EMI	Conducted Emissions *3		Conforms to EN 55011 Group 1 Class B and based on FCC Class B *12	
		Radiated Emissions		Conforms to EN 55011 Group 1 Class B *12	
	EMS	Electrostatic Discharge		Conforms to EN61000-4-2	
		Radiated Electromagnetic Field		Conforms to EN61000-4-3	
		Electrical Fast Transient/Burst		Conforms to EN61000-4-4	
Surge		Conforms to EN61000-4-5			
Conducted Disturbance		Conforms to EN61000-4-6			
Voltage Dips/Short Interruptions		Conforms to EN61000-4-11			
Approved standards *8		UL UR: UL 508 (Recognition), UL 60950-1 (Recognition) cUR: CSA C22.2 No.107.1, CSA C22.2 No. 60950-1 EN/VDE: EN50178 (= VDE 0160) Over voltage category III *9, EN 60950-1 (= VDE 0805 Teil 1) *9 (Terminal block: Based on DIN 50274 (VDE 0660-514))			
SEMI		SEMI F47-0706 (200-VAC input)			
Weight		1,200 g max. *10	1,800 g max. *10		

## S8JX

S8JX-G

- \*1. When a load is connected that has a built-in DC-DC converter, the overload protection may operate at startup and the Power Supply may not start. Refer to *Overload Protection on page 46*.
- \*2. Do not use an Inverter output for the Power Supply. Inverters with an output frequency of 50/60 Hz are available, but the rise in the internal temperature of the Power Supply may result in ignition or burning.
- \*3. Rated input voltage: 100 or 200 VAC at 100% load.
- \*4. Output characteristics: Specified at power supply output terminals.
- \*5. If the output voltage adjuster (V. ADJ) is turned, the voltage will increase by more than the allowable voltage range. When adjusting the output voltage, confirm the actual output voltage from the Power Supply and be sure that load is not damaged.
- \*6. For details, refer to *Overload Protection on page 46*.
- \*7. To reset the protection, turn OFF the input power for three minutes or longer and then turn it back ON.
- \*8. The range for compliance with EC Directives and safety standards (UL, EN, etc.) is 100 to 240 VAC (85 to 264 VAC).
- \*9. The 24-V models are scheduled to obtain certification in March 2012.
- \*10. The weight is of the type without a mounting bracket.
- \*11. S8JX-P600□□CD: 100 m/s<sup>2</sup>
- \*12. 300-W/600-W models conform to Class B with an aluminum plate set under the product.

S8JX-P

Common Precautions



# Connections

## Block Diagrams

S8JX-P050□□□□ (50 W)

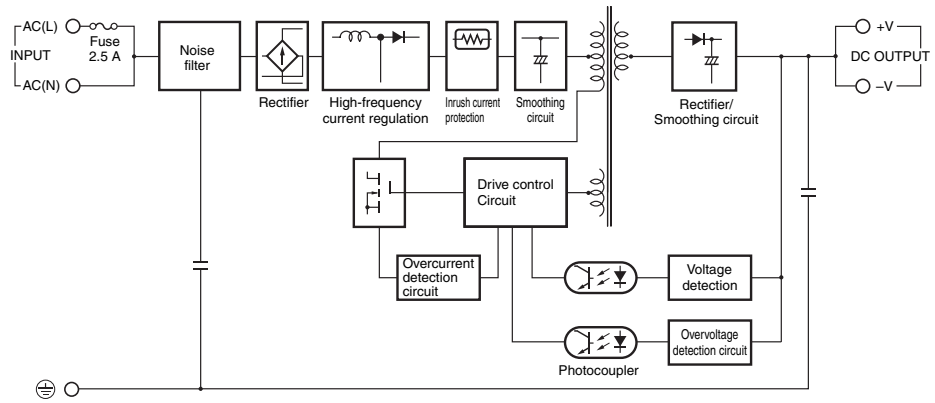

S8JX-P100□□□□ (100 W)

S8JX-P150□□□□ (150 W)

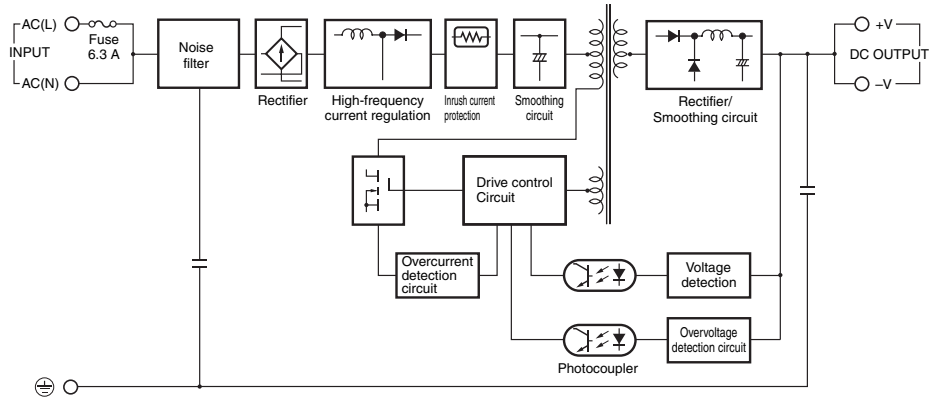

S8JX-G

S8JX-P

Common Precautions

S8JX-P300 (300 W)

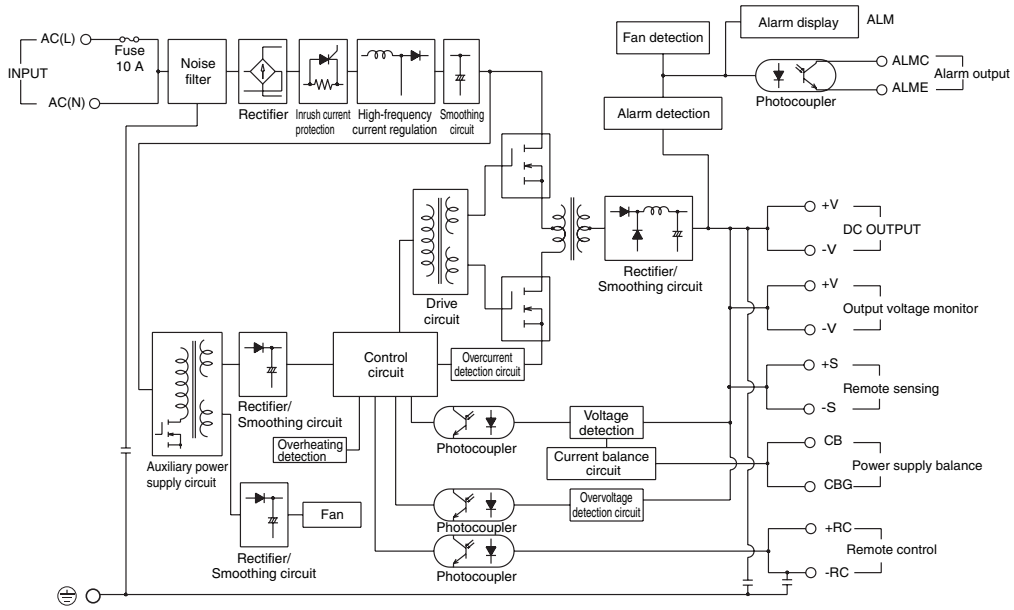

S8JX-P600 (600 W)

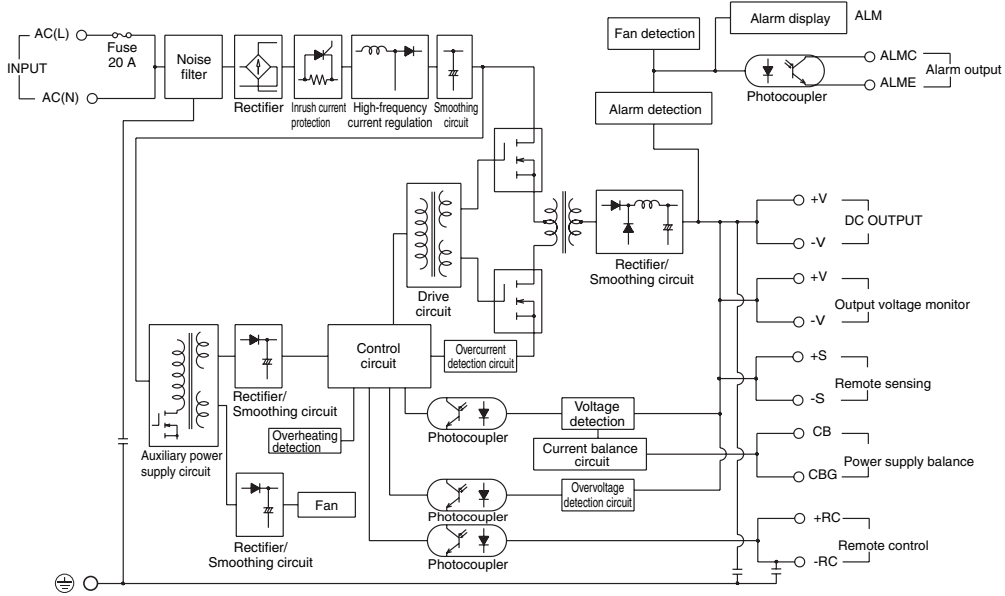

# Construction and Nomenclature

## Nomenclature

### 50-/100-/150-W Models

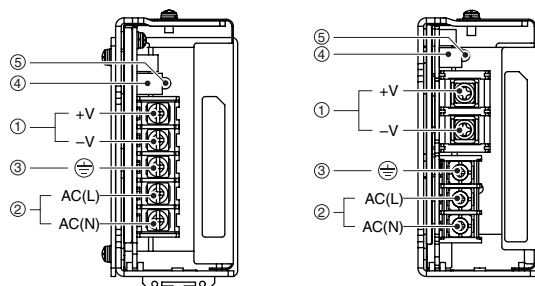

Note: The S8JX-P05005CD is shown above.

Note: The S8JX-P15005C is shown above.

No.	Name	Function
1	DC Output Terminals (-V), (+V)	Connect the load lines to these terminals.
2	AC Input Terminals (L), (N)	Connect the input lines to these terminals. *1
3	Protective Earth Terminal (PE) (⊕)	Connect the ground line to these terminals. *2
4	Output Voltage Adjuster (V. ADJ)	It is possible to increase or decrease the output voltage.
5	Output Indicator (DC ON: Green)	Lights green while a direct current (DC) output is ON.

\*1. The fuse is located on the (L) side. It is NOT user-replaceable. For a DC power input, connect the low side to the positive (+) terminal.

\*2. This is the protective earth terminal specified in the safety standards. Always ground this terminal.

### 300-W Models

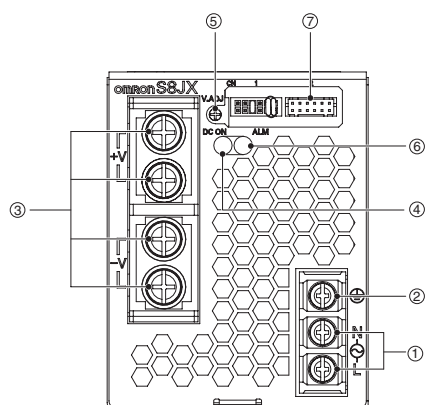

Note: The S8JX-P30024N is shown above.

No.	Name	Function
1	Input Terminals (L), (N)	Connect the input lines to these terminals. *1
2	Protective Earth Terminal (PE) (⊕)	Connect the ground line to these terminals. *2
3	DC Output Terminals (-V), (+V)	Connect the load lines to these terminals.
4	Output Indicator (DC ON: Green)	Lights green while a direct current (DC) output is ON.
5	Output Voltage Adjuster (V. ADJ)	It is possible to increase or decrease the output voltage.
6	Alarm indicator (ALM: Red)	This lamp lights up at the time of output voltage deterioration or fan stoppage, and in standby mode by remote control function.

### 600-W Models

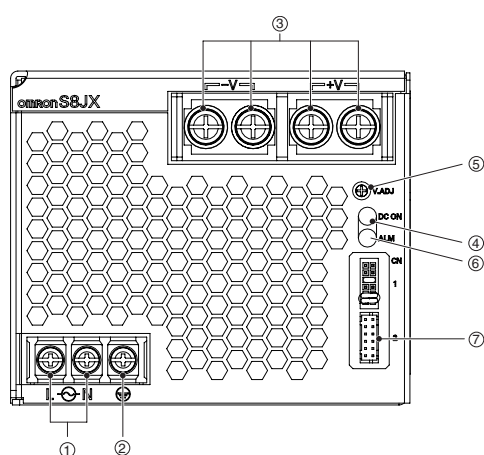

Note: The S8JX-P60024N is shown above.

No.	Name	Function
7	Signal output connector *3	<p>1: Output voltage monitor terminal (+V)</p> <p>2: Remote sensing terminal (+S)</p> <p>3: Output voltage monitor terminal (-V)</p> <p>4: Remote sensing terminal (-S)</p> <p>5: Current balance terminal (CB)</p> <p>6: Current balance ground terminal (CBG)</p> <p>7: Remote control terminal (+RC)</p> <p>8: Remote control terminal (-RC)</p> <p>9: (Not connected)</p> <p>10: (Not connected)</p> <p>11: Alarm detection output terminal (ALMC) (Collector side)</p> <p>12: Alarm detection output terminal (ALME) (Emitter side)</p>

\*1. The fuse is located on the (L) side. Ensure that the (L) side is set to (+).

\*2. This is a PE (Protective Earth) terminal defined in safety standards and must be grounded.

\*3. Signal input/output connectors are included as standard and implemented in the CN1 before shipment.

In this connector, the circuits of 1-2, 3-4, and 7-8 are shorted. Removal of the connector may deteriorate the output stability and accuracy, so be sure to perform the connection of +S and -S terminals.

Never connect a load to the output voltage monitor terminal (+V, -V).

## Reference Values

<b>Reliability (MTBF)</b>	50 W: 190,000 hrs 100 W: 160,000 hrs 150 W: 160,000 hrs 300 W: 160,000 hrs 600 W: 150,000 hrs
<b>Definition</b>	MTBF stands for Mean Time Between Failures, which is calculated according to the probability of accidental device failures, and indicates reliability of devices. Therefore, it does not necessarily represent a life of the product.
<b>Life expectancy</b>	10 yrs. min.
<b>Definition</b>	The life expectancy indicates average operating hours under the ambient temperature of 40°C and a load rate of 50%. Normally this is determined by the life expectancy of the built-in aluminum electrolytic capacitor.

Derating Curves (Standard Mounting)

50-/100-W Models

Front-mounting, DIN Rail mounting, Bottom-mounting, Side-mounting

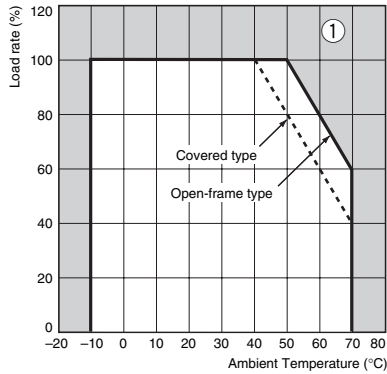

- Note: 1.** Internal parts may occasionally deteriorate or be damaged. Do not use the Power Supply in areas outside the derating curve (i.e., the area shown by shading ① in the above graph).
- 2.** If there is a derating problem, use forced air-cooling.
- 3.** (For Customers using 100-W type for a DC Input) When using an input voltage of less than 100 VDC, reduce the load calculated with the above derating curve by at least the following coefficients.  
When using a voltage exceeding 340 VDC, the ambient temperature should be 60°C or less.

S8JX-P 100-W Models

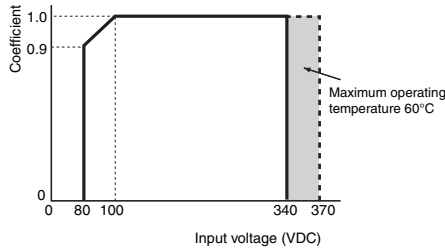

300-/600-W Models

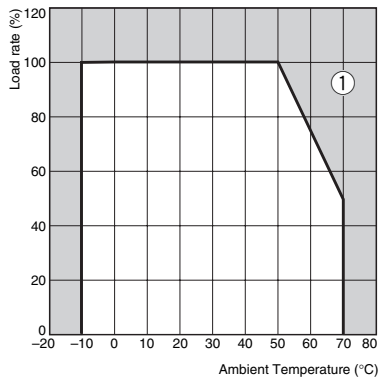

- Note: 1.** Internal parts may occasionally deteriorate or be damaged. Do not use the Power Supply in areas outside the derating curve (i.e., the area shown by shading ① in the above graph).
- 2.** The ambient temperature is defined at a location 50 mm forward from the center of the front surface of the product.
- 3.** (For Customers using 300-/600-W type for a DC Input) Reduce the load calculated with the above derating curve by at least the following coefficients.

S8JX-P 300-/600-W Models

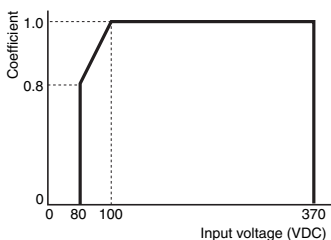

150-W Models

Front-mounting, DIN Rail mounting, Bottom-mounting

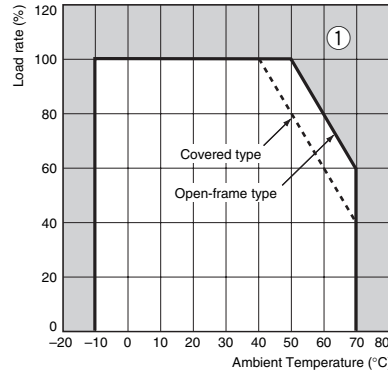

Horizontal-side-mounting

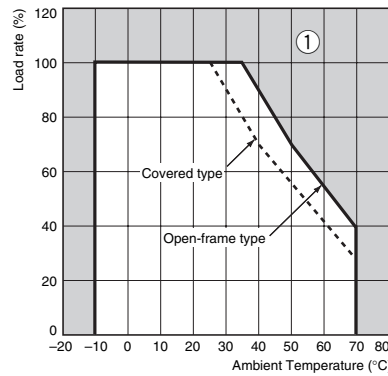

- Note: 1.** Internal parts may occasionally deteriorate or be damaged. Do not use the Power Supply in areas outside the derating curve (i.e., the area shown by shading ① in the above graph).
- 2.** If there is a derating problem, use forced air-cooling.
- 3.** (For customers using 150-W type for a DC Input) When using an input voltage of less than 100 VDC, reduce the load calculated with the above derating curve by at least the following coefficients.  
When using a voltage exceeding 340 VDC, the ambient temperature should be 60°C or less.

S8JX-P 150-W Models

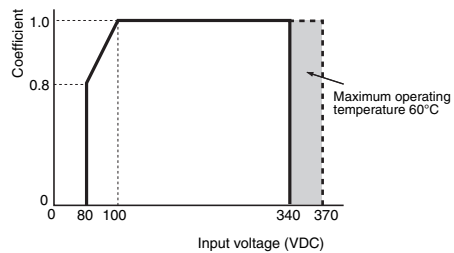

**Mounting**

**50-/100-/150-W Models**

The following three mounting methods are possible.

- Ⓐ. Front-mounting: Refer to *Mounting Bracket Provided with Front-mounting Power Supplies* Ⓐ on page 54.
- Ⓑ. Bottom-mounting
- Ⓒ. Side-mounting

**Note:** Additional mounting methods are also available using DIN Rail-mounting models.

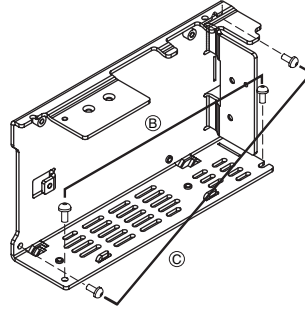

**Standard Mounting**

**50-/100-/150-W Models**

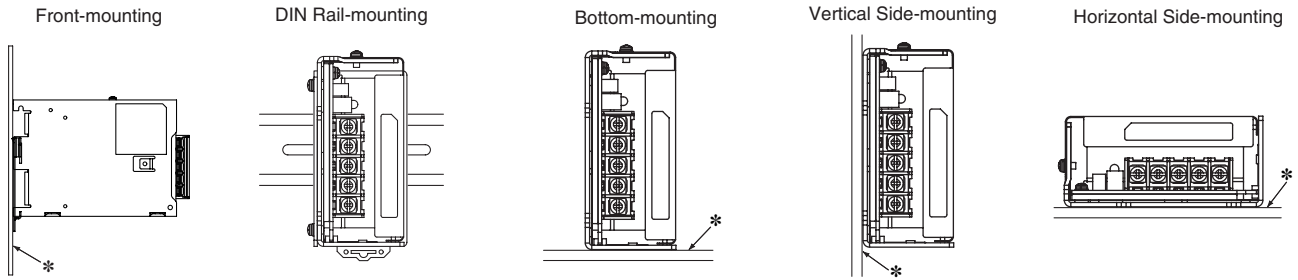

- Note:**
1. Improper mounting will interfere with heat dissipation and may occasionally result in deterioration or damage of internal parts. Use the standard mounting method only.
  2. When mounting the Power Supply, mounting it to a metal plate (\*) is recommended.
  3. Install the Power Supply so that the air flow circulates around the Power Supply, as the Power Supply is designed to radiate heat by means of natural air flow.

**300-/600-W Models**

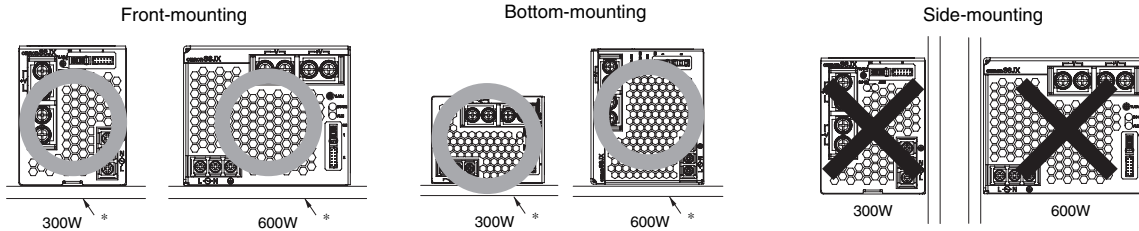

- Note:**
1. Improper mounting will interfere with heat dissipation and may occasionally result in deterioration or damage of internal parts. Use the standard mounting method only.
  2. When mounting the Power Supply, mounting it to a metal plate (\*) is recommended.
  3. Do not cover the air holes (provided at fan mounted side and the opposite side) to have enough air-cooling.

**Remote sensing function**

This function is used when compensating the voltage drop of the load line.

The remote sensing function is operated by connecting +S terminal (2 pin on CN) to +side of the load terminal and -S terminal (4 pin on CN) to -side of the load terminal.

When the remote sensing function is not used, using a connector provided as standard enables the connection between +S and +V terminals (1 pin on CN) and between -S and -V terminals (3 pin on CN) respectively.

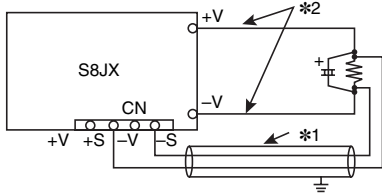

- Note:**
1. Use a two-core shield wire for connection line (\*1).
  2. If the voltage drop on a load line (\*2) is large, the output voltage of the power supply may rise by the voltage drop amount and activate the overvoltage protection. Therefore, be sure to use as thick a wire as possible.
  3. Be sure to use the voltage drop at 0.3 V or less.
  4. If the load line is long, be sure to use an electrolytic capacitor between the load terminals. As the used electrolytic capacitor may be heated by ripple current due to the connected load, be sure to use an electrolytic capacitor having an allowable ripple current exceeding the used ripple current.
  5. Opening status of +S and -S terminals may deteriorate the output stability and accuracy. Therefore, be sure to connect +S and -S terminals.
  6. Remove a connector provided as standard and prepare a harness separately.

**Remote control function**

This function is to turn ON/OFF the output by an external signal using +RC terminal (7 pin on CN) and -RC terminal (8 pin on CN) while input voltage remains applied. To use this function, connect a switch or a transistor to +RC and -RC terminals.

When not in use, use the standard supplied connector to short-circuit +RC and -RC terminals.

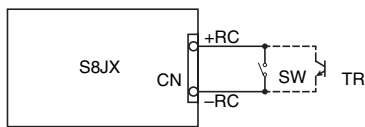

Level	Output voltage	Built-in fan
Short or L (0-0.8 V)	ON	Rotation
Open or H (2.4-12 V)	OFF	Stop

**Max. applied voltage: 12 V max., Counter voltage: -1 V max., Sink current: 3.5 mA**

- Note:**
1. If counter voltage is applied to remote control terminals, output voltage cannot be turned ON/OFF. Please remember this when wiring.
  2. Use a twist wire or a two-core shield wire for connection line.
  3. Remote control circuit is disconnected from input and output circuits.
  4. Remove a connector provided as standard and prepare a harness separately.

**Alarm detection function**

When output voltage drops due to overcurrent protection, overvoltage protection, or overheat protection in operation or input voltage drop, when the built-in fan stops, or when the Power Supply goes standby by remote control, the alarm indicator (LED: red) lights up to indicate the output voltage trouble. In addition, the transistor outputs that outside.

Transistor output: 30 VDC max., 50 mA max.  
 Residual voltage when the function is ON: 2 V max., leakage current when the function is OFF: 0.1 mA max.  
 Detection voltage: approximately 80% of the output voltage setting value  
 When trouble is detected, the transistor output is turned OFF (nonconductive pins 11-12 on CN) and the LED (red) lights up.

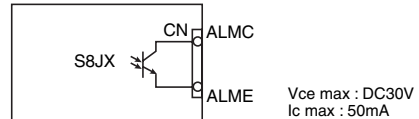

- Note:**
1. The alarm detection function monitors the voltage at the Power Supply output end. To check an accurate voltage, measure a voltage at the load end.
  2. Remove the standard supplied connector and prepare a connector separately.

**Overload Protection**

The Power Supply is provided with an overload protection function that protects the power supply from possible damage by overcurrent. When the output current rises above 105% to 160% min. of the rated current, the protection function is triggered, decreasing the output voltage. When the output current falls within the rated range, the overload protection function is automatically cleared.

- Note:**
1. When a load is connected that has a built-in DC-DC converter, the overload protection may operate at startup and the power supply may not start.
  2. Internal parts may occasionally deteriorate or be damaged if a short-circuited or overcurrent state continues during operation.
  3. Internal parts may possibly deteriorate or be damaged if the Power Supply is used for applications with frequent inrush current or overloading at the load end. Do not use the Power Supply for such applications.

**(Reference value)**

**50-W Models**

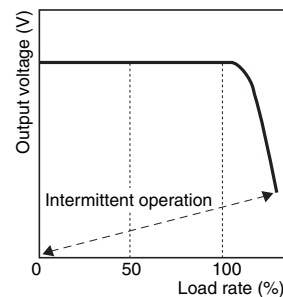

**100-/150-W Models**

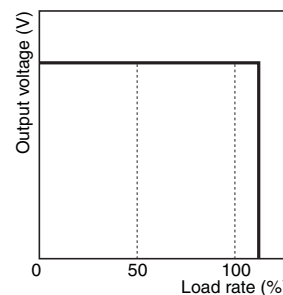

**300-/600-W Models**

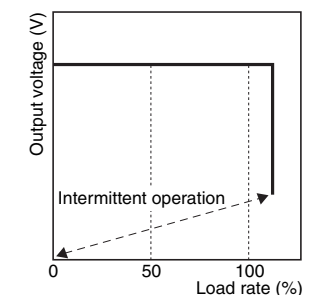

## Overvoltage Protection

### 50-/100-/150-W Models

Consider the possibility of an overvoltage and design the system so that the load will not be subjected to an excessive voltage even if the feedback circuit in the power supply fails. When an excessive voltage that is approximately 130% of the rated voltage or more is output, the output voltage is shut OFF, preventing damage to the load due to overvoltage. Reset the input power by turning it OFF for at least three minutes and then turning it back ON again.

### 300-/600-W Models

Consider the possibility of an overvoltage and design the system so that the load will not be subjected to an excessive voltage even if the feedback circuit in the Power Supply fails. When an excessive voltage that is approximately 130% of the rated voltage or more is output, the output voltage is shut OFF, preventing damage to the load due to overvoltage and simultaneously the alarm indicator will be lit. Reset the input power by turning it OFF for at least three minute and then turning it back ON again.

#### (Reference value)

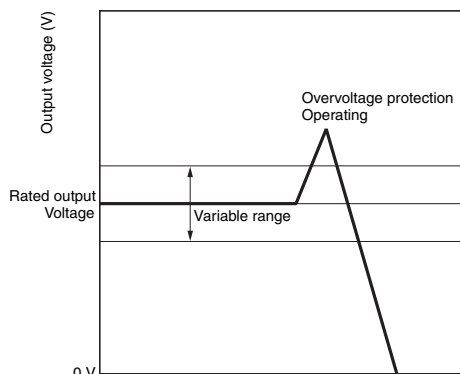

**Note:** Do not turn ON the power again until the cause of the overvoltage has been removed.

## Output peak current (300-W 24V, 600-W 24V Models)

The following conditions should be satisfied for the peak current value.

- $t_1 \leq 10 \text{ s}$
- $I_p \leq \text{rated peak current}$
- $I_{ave} \leq \text{rated current}$

$$\text{Duty} = \frac{t_1}{t_1+t_2} \times 100 [\%] \leq 35\% \text{ (180 to 240 VAC)}$$

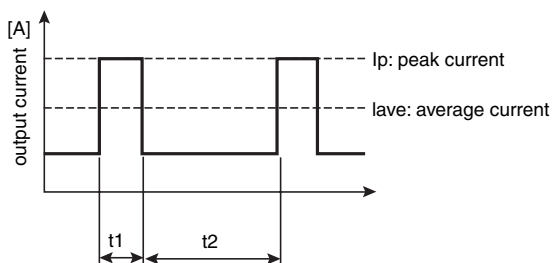

- Note: 1.** Do not hold peak load current over 10 seconds.  
In addition, you should not use duty cycle under conditions beyond above figure.  
It may cause damage in its power supply.
2. Please derate peak load current depending on ambient temperature and mounting orientation.
  3. Please keep the average current of peak load cycle from becoming more than the rated value.

## Overheat Protection

### 300-/600-W Models

If the internal temperature rises excessively as a result of fan failure or any other reason, the overheat protection circuit will be triggered to shut OFF the output voltage.

The alarm indicator lights at the same time. Reset the input power by turning it OFF for at least three minutes and then turning it back ON again.

## Inrush Current, Startup Time, Output Hold Time

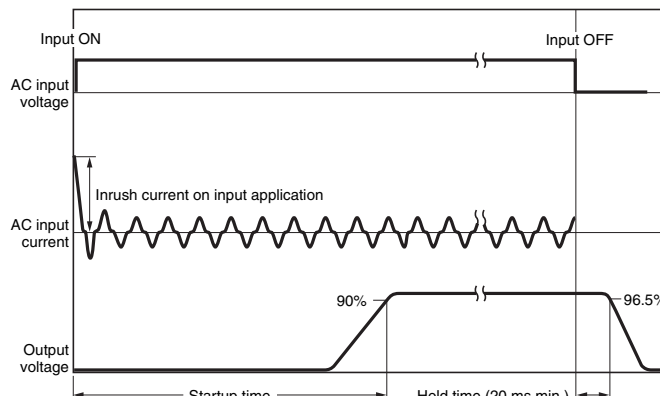

**Note:** A maximum startup time of 1,000 ms is required. Construct a system configuration that considers the startup time of other devices.

# S8JX

## Dimensions

(Unit: mm)

### Front-mounting Models

S8JX-P050□□ (50 W)

S8JX-P050□□C (50 W)

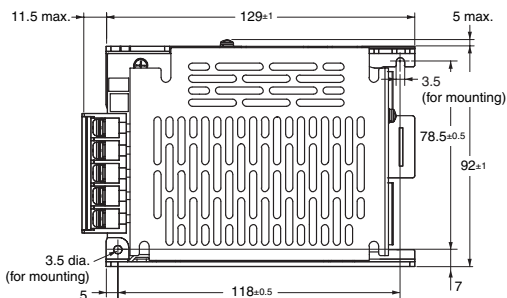
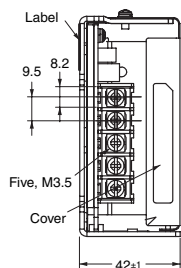

#### Panel mounting holes dimensions

Surface screw mounting	
Side Mounting	Two, M3 78.5±0.5 118±0.5
	Two, M3 120±0.5

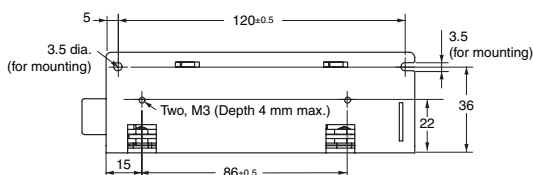

S8JX-P100□□ (100 W)

S8JX-P100□□C (100 W)

S8JX-P15012 (150 W)

S8JX-P15012C (150 W)

S8JX-P15024 (150 W)

S8JX-P15024C (150 W)

S8JX-P15048 (150 W)

S8JX-P15048C (150 W)

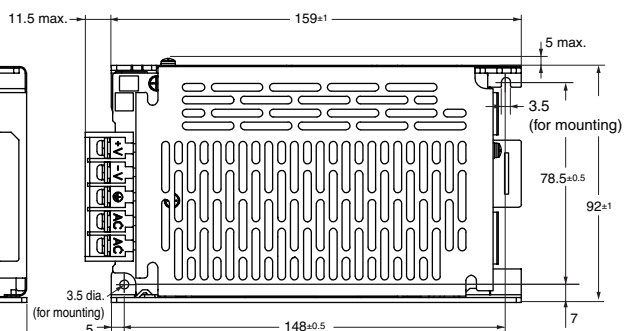
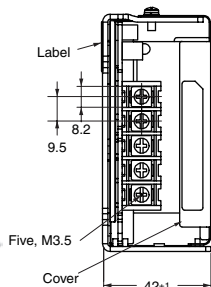

#### Panel mounting holes dimensions

Surface screw mounting	
Side Mounting	Two, M3 78.5±0.5 148±0.5
	Two, M3 150±0.5

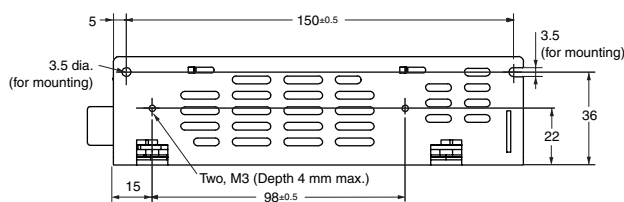

S8JX-G

S8JX-P

Common Precautions



S8JX-P15005 (150 W)  
S8JX-P15005C (150 W)

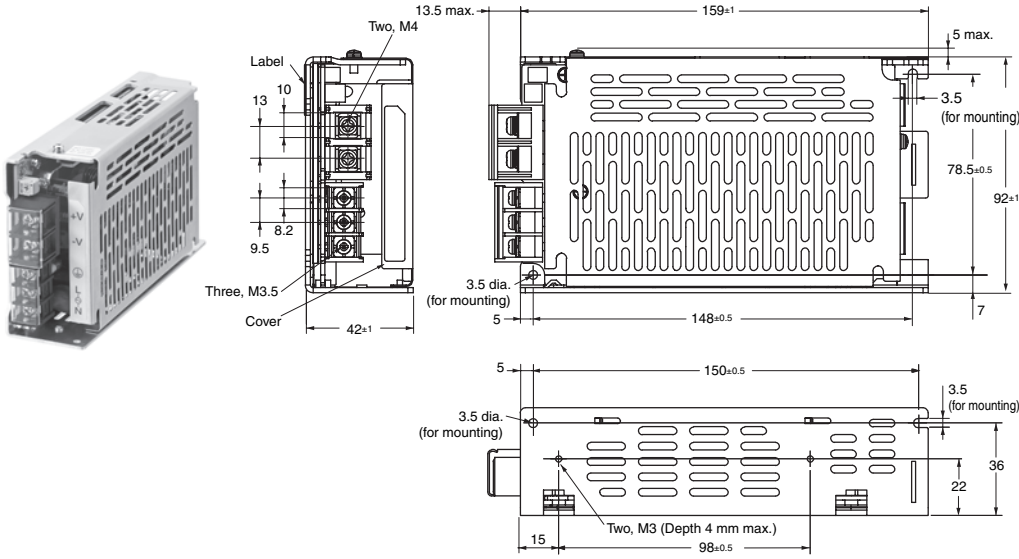

Panel mounting holes dimensions

Surface screw mounting	
Side Mounting	<p>Two, M3 78.5±0.5 148±0.5</p>
Bottom Mounting	<p>Two, M3 150±0.5</p>

S8JX-G

S8JX-P

Common Precautions

# S8JX

S8JX-G

## S8JX-P300□□C (300 W)

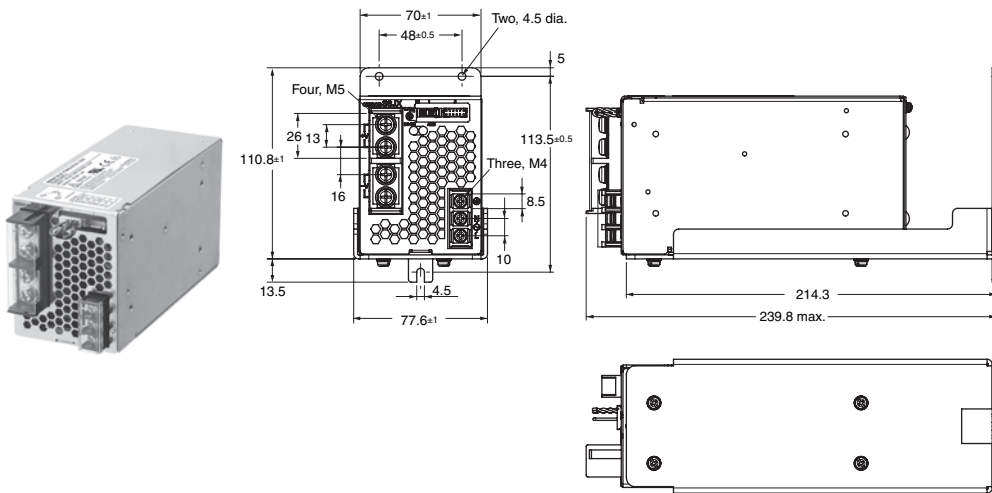

### Panel mounting holes dimensions

	Rear surface screw mounting
Front Mounting	

S8JX-P

## S8JX-P300□□N (300 W)

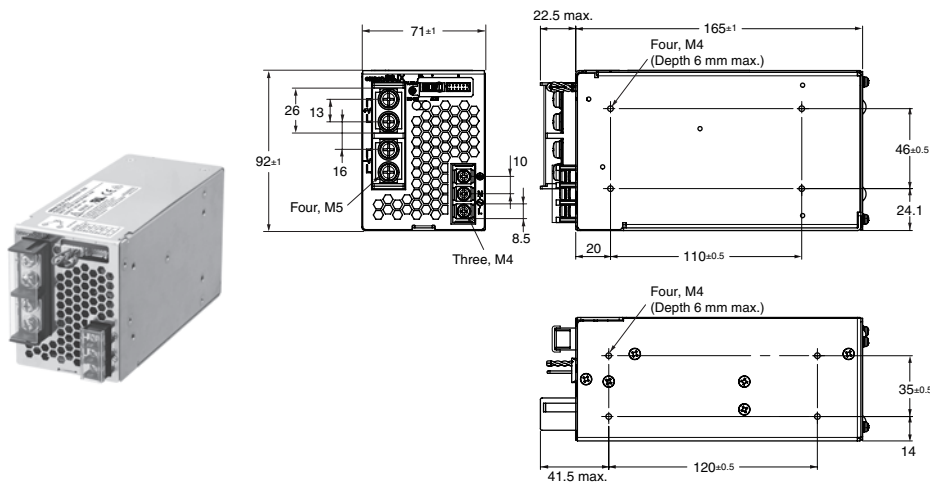

### Panel mounting holes dimensions

	Rear surface screw mounting
Standard Mounting	
Side Mounting	

Common Precautions

S8JX-P600□□C (600 W)

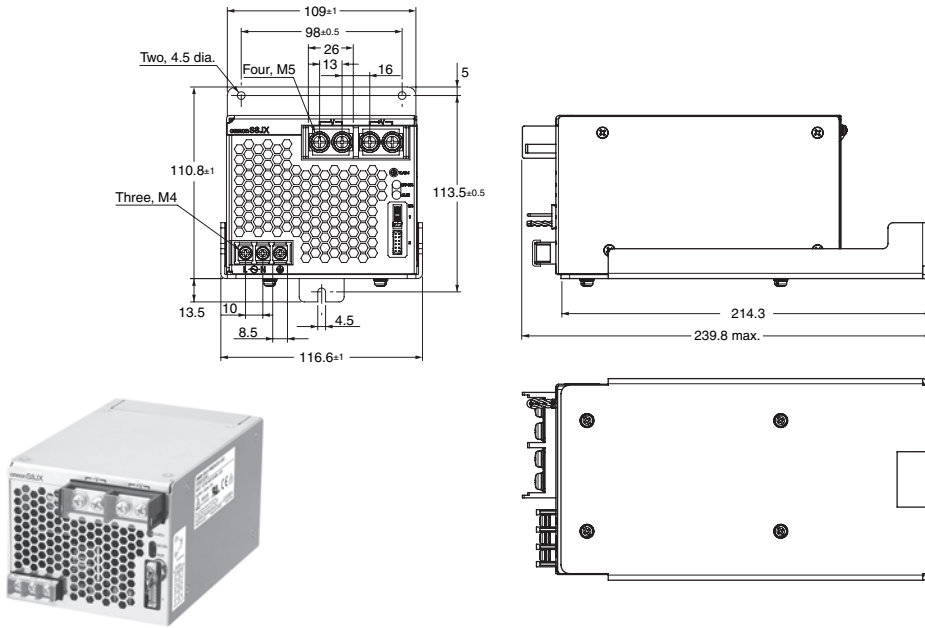

Panel mounting holes dimensions

	Rear surface screw mounting
Front Mounting	

S8JX-P600□□N (600 W)

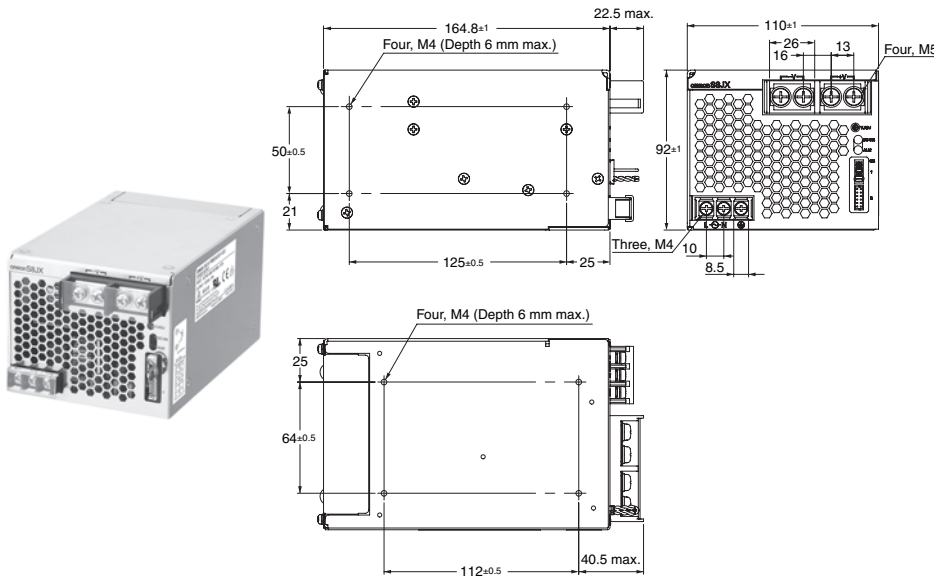

Panel mounting holes dimensions

	Rear surface screw mounting
Standard Mounting	
Side Mounting	

S8JX-G

S8JX-P

Common Precautions

# S8JX

## DIN Rail-mounting Models

S8JX-P050□□D (50 W)  
S8JX-P050□□CD (50 W)

S8JX-G

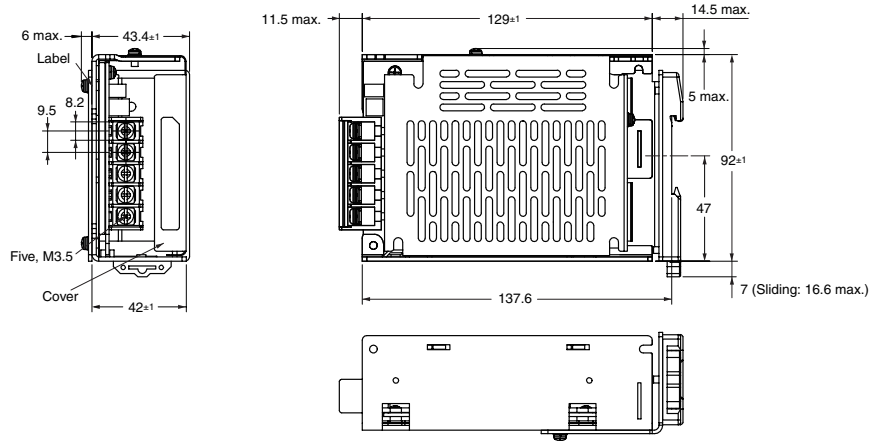

S8JX-P100□□D (100 W)  
S8JX-P100□□CD (100 W)  
S8JX-P15012D (150 W)  
S8JX-P15012CD (150 W)  
S8JX-P15024D (150 W)  
S8JX-P15024CD (150 W)  
S8JX-P15048D (150 W)  
S8JX-P15048CD (150 W)

S8JX-P

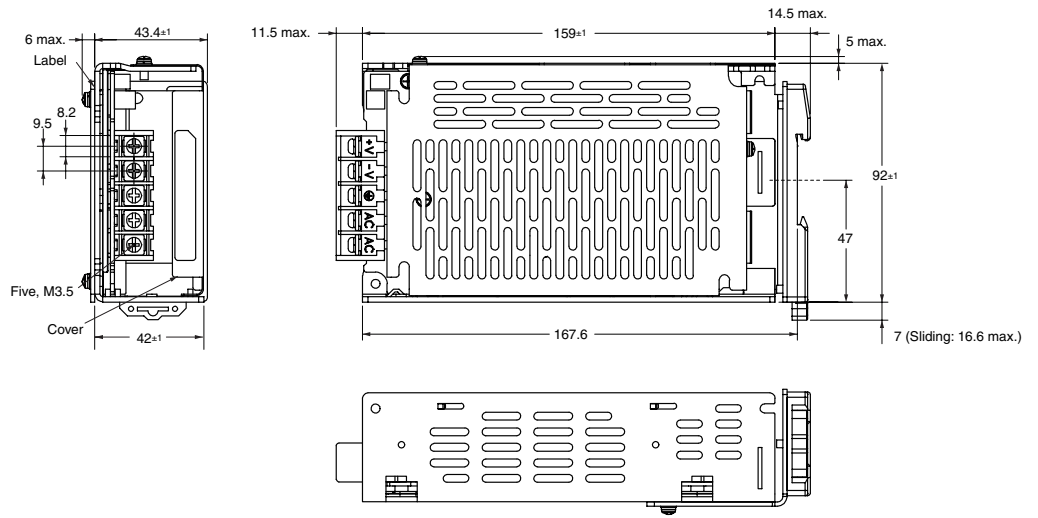

S8JX-P15005D (150 W)  
S8JX-P15005CD (150 W)

Common Precautions

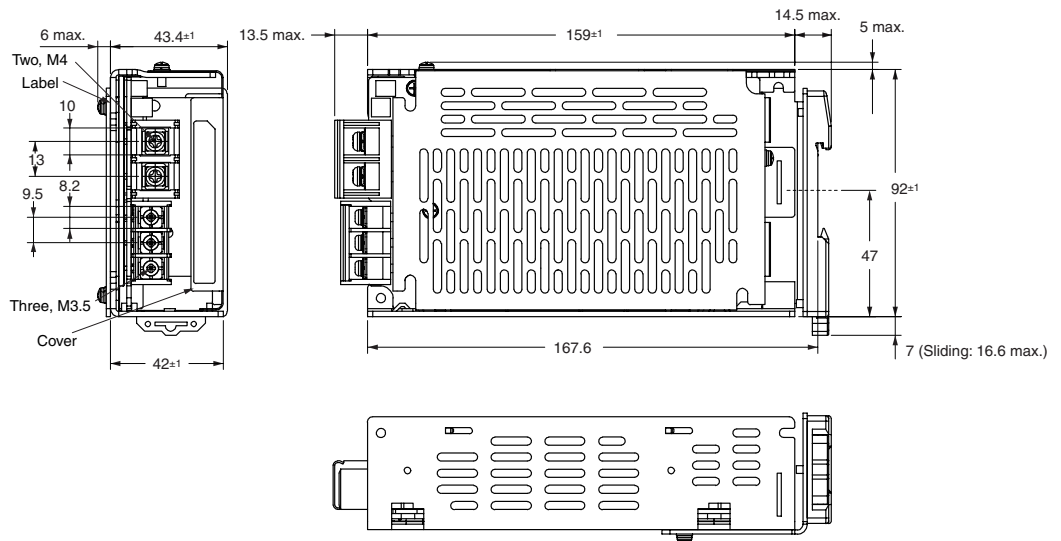

S8JX-P300□□CD (300 W)

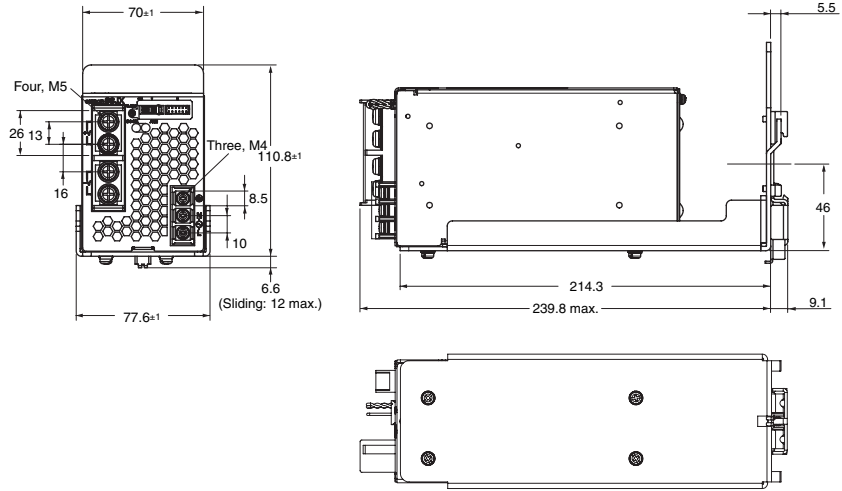

**Note:** Use a metal DIN Rail when mounting a 300-W model to a DIN Rail.

S8JX-P600□□CD (600 W)

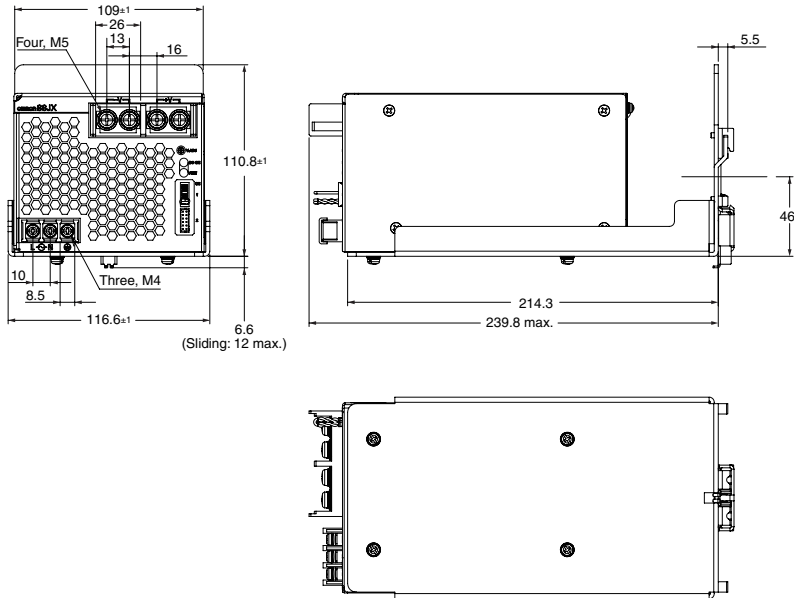

**Note:** Use a metal DIN Rail when mounting a 600-W model to a DIN Rail.

**Mounting Bracket Provided with Front-mounting Power Supplies (A)**  
**50-/100-/150-W Models**

**S82Y-J00F Front-mounting Bracket**

**Front-mounting Method**

Temporarily attach the enclosed mounting bracket as shown in the illustration on the right, hook the holes (parts a) in the Power Supply on hooks on the mounting bracket (parts b), and secure the Power Supply with two mounting screws.

**Note:** Mounting screws are not provided.

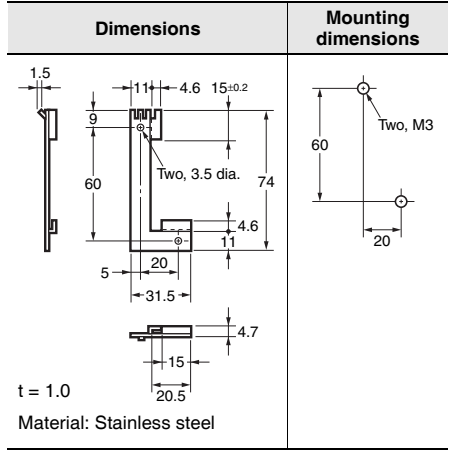
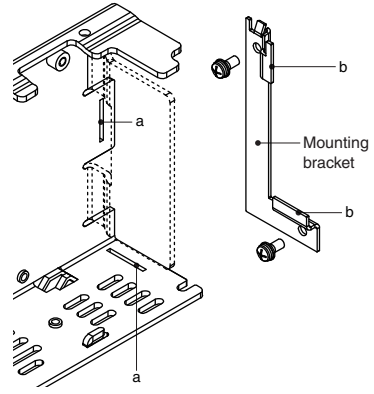

**DIN Rail (Order Separately)**

**Mounting Rail (Material: Aluminum)**

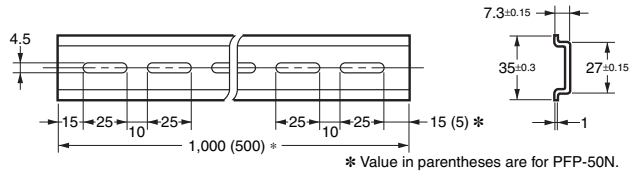
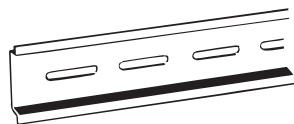

Model
PFP-100N
PFP-50N

**Mounting Rail (Material: Aluminum)**

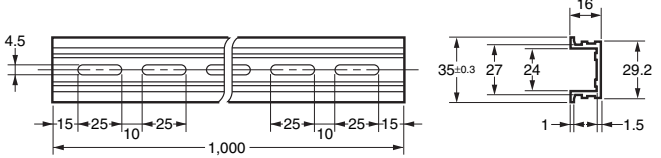
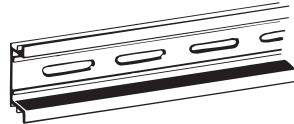

Model
PFP-100N2

**End Plate**

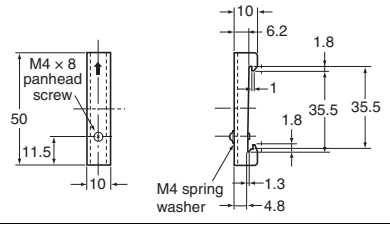
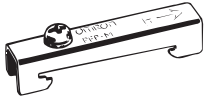

Model
PFP-M

- Note:**
- If there is a possibility that the Unit will be subject to vibration or shock, use a steel DIN Rail. Otherwise, metallic filings may result from aluminum abrasion.
  - If the Unit may be subjected to sliding to either side, attach an End Plate (model PFP-M) on each side of the Unit.

**Terminal Cover (Order Separately)**

Terminal Cover model	Applicable Power Supply and applicable location
S82Y-JTC1	S8JX-P50W
	S8JX-P100W
	S8JX-P150W 12-V, 24-V or 48-V output

**Replacement Fan (sold separately)**

Product	Model
Replacement fan unit for 300-W models	S82Y-JXP30FAN
Replacement fan unit for 600-W models	S82Y-JXP60FAN

## Safety Precautions

Refer to *Safety Precautions for All Power Supplies*.

### CAUTION

Minor electric shock, fire, or Product failure may occasionally occur. Do not disassemble, modify, or repair the Product to touch the interior of the Product.



Minor burns may occasionally occur. Do not touch the Product while power is being supplied or immediately after power is turned OFF.



Fire may occasionally occur. Tighten terminal screws to the specified torque.

M3.5, M4:1.13 N·m.

(The DC output terminal of S8JX-G15005□□ and S8JX-P15005:1.56 N·m.)

M5:2.25 N·m.



Minor injury due to electric shock may occasionally occur. Do not touch the terminals while power is being supplied. Always close the terminal cover after wiring.



Minor electric shock, fire, or Product failure may occasionally occur. Do not allow any pieces of metal or conductors or any clippings or cuttings resulting from installation work to enter the Product.



### Precautions for Safe Use

#### Mounting

- Take adequate measures to ensure proper heat dissipation to increase the long-term reliability of the Product.
- The 300 W 24V, 48V models of S8JX-G series are designed to radiate heat by means of natural air-flow. Be sure to allow convection in the atmosphere around devices when mounting. Do not use in locations where the ambient temperature exceeds the range of the derating curve.
- The 300 W 5V, 12V, 600 W models of S8JX-G series, and 300 W, 600 W models of S8JX-P series are designed to radiate heat by means of forced air-flow. Do not cover the air holes (provided at fan mounted side and the opposite side) to have enough air-cooling.
- The screws must not protrude beyond the following values inside the Power Supply when screw holes provided on the chassis are used.  
15 W, 35 W, 50 W, 100 W, or 150 W: 4 mm  
300 W or 600 W of S8JX-P series: 6 mm  
300 W or 600 W of S8JX-G series: 8 mm  
Mounting screw tightening torque (recommended value) : 0.54 N·m.
- Front mounting is possible using provided mounting bracket.
- When cutting out holes for mounting, make sure that cuttings do not enter the interior of the Products.
- Improper mounting will interfere with heat dissipation and may occasionally result in deterioration or damage of internal parts. Use the standard mounting method only.
- The internal parts may occasionally deteriorate and be broken due to adverse heat radiation. Do not loosen the screw on the side face of the main body.
- When mounting two or more Power Supplies side-by-side, allow at least 20 mm for S8JX-G series and 15 mm for S8JX-P series spacing between them.
- Provide a space of at least 20 mm back and forth for S8JX-G series, and 50 mm back and forth for S8JX-P series when mounting 300-W and 600-W models as well.
- Use the metal plate as the mounting panel.
- Minor fire may occasionally occur. Set the input voltage switch to the input voltage that is to be used (150-W, 5-V models of S8JX-G series only).

#### 15-/35-/50-/100-/150-W Models

Standard Mounting  
(Front-mounting and DIN Rail-mounting)

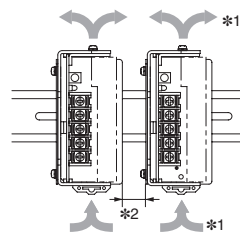

Standard Mounting  
(Bottom-mounting)

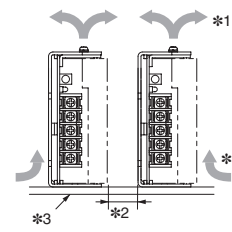

Standard Mounting  
(Horizontal Mounting)

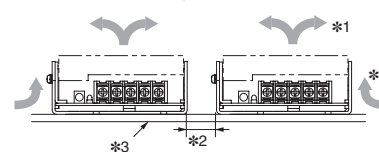

#### S8JX-G Series 300-W 5V, 12V Model

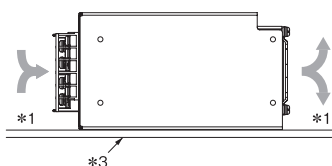

#### S8JX-G Series 300-W 24V, 48V Model

Standard Mounting  
(Front-mounting and DIN Rail-mounting)

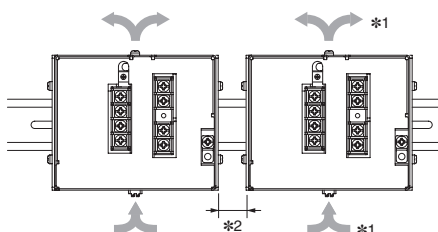

Standard Mounting  
(Bottom-mounting)

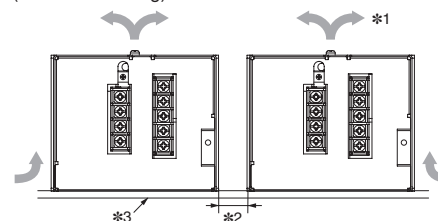

\*1. Convection of air

\*2. 20 mm min. (15 mm min. for S8JX-P series)

\*3. Use a metal plate as the mounting surface.

## S8JX-P Series 300-W Models

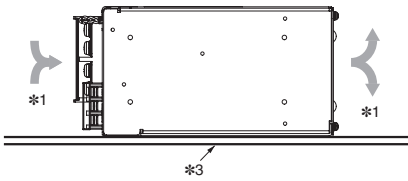

## S8JX-G Series 600-W Models

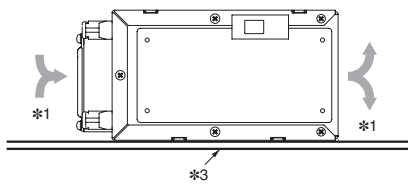

## S8JX-P Series 600-W Models

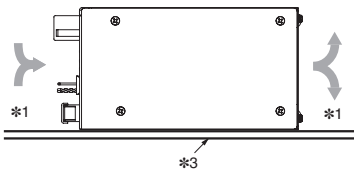

- \*1. Convection of air
- \*2. 20 mm min. (15 mm min. for S8JX-P series)
- \*3. Use a metal plate as the mounting surface.

### Wiring

- Connect the ground completely. A protective earthing terminal stipulated in safety standards is used. Electric shock or malfunction may occur if the ground is not connected completely.
- Minor fire may possibly occur. Ensure that input and output terminals are wired correctly.
- Do not apply more than 75 N force to the terminal block when tightening it.
- Be sure to remove the sheet covering the Product for machining before power-ON so that it does not interfere with heat dissipation.
- Use the following material for the wires to be connected to the S8JX to prevent smoking or ignition caused by abnormal loads.

### Recommended Wire Type

15 W, 35 W		AWG12 to AWG20 (a cross section of 0.517 to 3.309 mm <sup>2</sup> ) UL-certified temperature of at least 75°C
50W, 100W, 150 W (except for 5 V)		AWG12 to AWG16 (a cross section of 1.309 to 3.309 mm <sup>2</sup> ) UL-certified temperature of at least 60°C or 60/75°C
150 W at 5 V	Input side	AWG12 to AWG16 (a cross-section of 1.309 to 3.309 mm <sup>2</sup> ) UL-certified temperature of at least 60°C or 60/75°C
	Output side	AWG8 to AWG14 (a cross-section of 2.081 to 8.368 mm <sup>2</sup> ) UL-certified temperature of at least 60°C or 60/75°C
S8JX-G series 300W 5V, 12V 600W 5V, 12V S8JX-P series 300 W, 600 W	Input side	AWG12 to AWG20 (a cross section of 0.517 to 3.309 mm <sup>2</sup> ) UL-certified temperature of at least 60°C or 60/75°C
	Output side	AWG6 to AWG20 (a cross section of 0.517 to 13.30 mm <sup>2</sup> ) UL-certified temperature of at least 60°C or 60/75°C
S8JX-G series 300 W 24V, 48V, 600 W 24V, 48V		AWG12 to AWG20 (a cross section of 0.517 to 3.309 mm <sup>2</sup> ) UL-certified temperature of at least 60°C or 60/75°C

\* The rated current for the output terminals on the S8JX-G30005□□, S8JX-G30012□□, S8JX-G60005□, S8JX-G60012□, S8JX-P300□□ and S8JX-P600□□ is 60A for each terminal. The rated current for the output terminals on the S8JX-G30024□□, S8JX-G30048□□, S8JX-G60024□, and S8JX-G60048□ is 20 A for each terminal. Use two terminals together if the current flow is higher than the rated terminal current.

### Method of Manufacturing Connector Harness for Signal I/O

For S8JX-P Series 300-/600-W models, PHD connectors manufactured by JST Mfg. Co., Ltd. should be used.

Connector used	S12B-PHDSS	Manufactured by JST Mfg. Co., Ltd.
Housing	PHDR-12VS	
Terminal	SPHD-001T-P0.5 or BPHD-001T-P0.5	

To ensure correct wiring, the following points should be borne in mind when manufacturing the connector. It is recommended that the JST Mfg. Co., Ltd. catalog be read for further details.

- Electric cable size AWG26 to AWG22 should be used.
- The electric cable sheath stripping length should be approximately 2.3 mm.
- Dedicated tool YC (Manufactured by JST Mfg. Co., Ltd.) should be used for crimping of terminals and wiring.
- Although UL1007 (Twisted wire) and other equivalent twisted wires can be used for electric cables, UL1061 with a small outer sheath shape and equivalent twisted wires should be used for AWG22.
- When accommodating crimped terminal wiring in the housing, insert the wiring as far as possible to the back of the housing in a single movement and check for an audible click. In addition, check that wiring inserted in the housing is properly locked in place.

### Installation Environment

- Do not use the Power Supply in locations subject to shocks or vibrations. In particular, install the Power Supply as far away as possible from contactors or other devices that are a vibration source.
- Install the Power Supply well away from any sources of strong, high-frequency noise and surge.

### Ambient Operating and Storage Environments

- Store the Power Supply at a temperature of -25 to 65°C (-25 to 75°C for S8JX-P series) and a humidity of 25% to 90%.
- The Internal parts may occasionally deteriorate or be damaged. Do not use the Power Supply outside the derating range (i.e., the area shown by shading ① in the derating curve diagram on page 44.)
- Use the Power Supply at a humidity of 25% to 85%.
- Do not use the Power Supply in locations subject to direct sunlight.
- Do not use locations where liquids, foreign matter, or corrosive gases may enter the interior of the Product.

### Overload Protection

- Internal parts may possibly deteriorate or be damaged if a short-circuited, overload or peak load state continues during operation.
- Internal parts may possibly deteriorate or be damaged if the Power Supply is used for applications with frequent inrush current or overloading at the load end. Do not use the Power Supply for such applications.

### Charging a Battery

When connecting a battery at the load, connect an overcurrent limiting circuit and overvoltage protection circuit.



### Output Voltage Adjuster (V.ADJ)

- The output voltage adjuster (V.ADJ) may possibly be damaged if it is turned with unnecessary force. Do not turn the adjuster with excessive force.
- After completing output voltage adjustment, be sure that the output capacity or output current does not exceed the rated output capacity or rated output current.

### Ripple Noise Voltage (S8JX-G Series 300-W, 5 V and 600-W 5 V or 12 V Models)

The specified standard for the ripple voltage noise was measured with a measurement circuit that is based on JEITA standard RC-9131A.

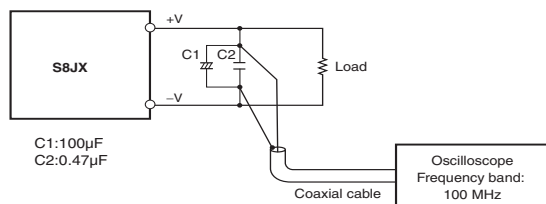

### DIN Rail-mounting

To mount the Power Supply to a DIN Rail, pull down the rail stopper until you hear it clicks open, hook portion (A) of the Power Supply onto the DIN Rail, press the Power Supply in direction (B), and then push up the rail stopper to lock the Power Supply in place.

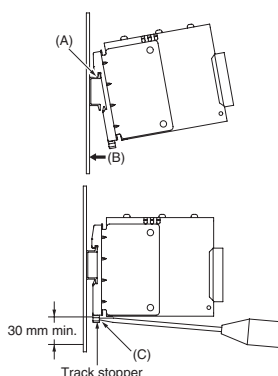

To dismount the Power Supply, pull down portion (C) with a flat-blade screwdriver and pull out the Power Supply.

### Series Operation

Two power supplies can be connected in series. The (±) voltage output can be accomplished with two Power Supplies.

#### Series Operation Correct

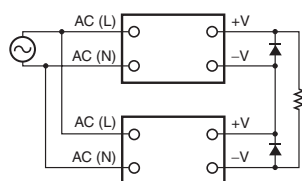

#### Output Voltage (±) Correct

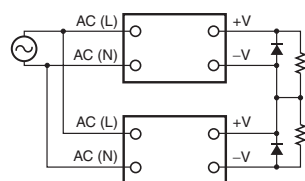

**Note: 1.** If the load is short-circuited, a reverse voltage will be generated inside the Power Supply. If this occurs the Power Supply may possibly deteriorate or be damaged. Always connect a diode as shown in the figure. Select a diode having the following ratings.

Type	Schottky Barrier diode
Dielectric strength (VRRM)	Twice the rated output voltage or above
Forward current (IF)	Twice the rated output current or above

**2.** Although Products having different specifications can be connected in series, the current flowing through the load must not exceed the smaller rated output current.

### Parallel Operation

#### 15-/35-/50-/100-/150-W Models

Parallel operation is not possible.

#### Parallel Operation Incorrect

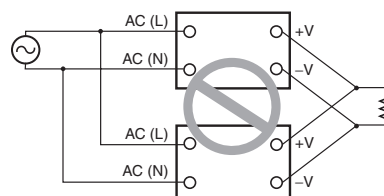

#### S8JX-G Series 300-/600-W Models

Parallel operation is possible under 80% of the rated value.

- To operate in parallel, set the switch to the "PARALLEL" side.
- The length and thickness of each wire connected to the load must be the same so that there is no difference in voltage drop value between the load and the output terminals of each Power Supply.
- It is desirable to set the same value on the voltage adjuster of each Power Supply.

#### Parallel Operation Correct

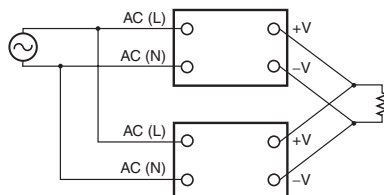

### S8JX-P Series 300-/600-W Models

Connecting CB terminal (5 pin on CN) and CBG terminal (6 pin on CN) enables the current balancing function and that allows the parallel operation at 80% or less of the total output capacity.

Up to five Power Supplies can be connected.

- Use 2-conductor shielded cable as a connection wire (\*1).
- Adjust the output voltage difference of each Power Supply to 100 mV or less or 1% or less of the rated output voltage, whichever is smaller, using the output voltage adjuster (V. ADJ).  
During parallel operation, load current may be biased to one side, resulting in damage to internal components.
- Parallel operation is used to increase static capacity. The output voltage may drop with sudden load fluctuations.
- There may be steps in the rising waveform of the output voltage during parallel operation.
- Remove the standard supplied connector and prepare a connector separately.

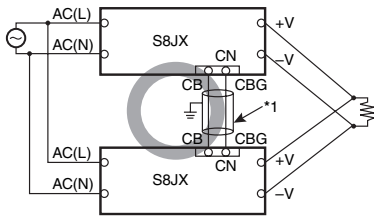

### Backup operation

Backup operation is possible. (Requires an external diode.)

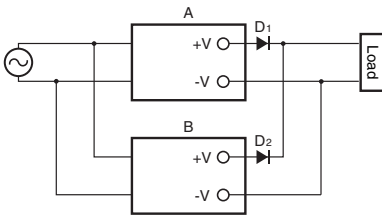

The same model should be used for power supplies A and B.

- Type: Schottky Barrier diode
- Withstand voltage (VRRM): Equivalent to or higher than the rated power supply output voltage
- Forward current (IF): Double the rated power supply output current or higher

- The output voltages of power supplies A and B output should be set higher only by a value equivalent to the drop in diode  $D_1$  and  $D_2$  forward voltages ( $V_F$ ).  
In addition, since power loss occurs resulting from power supply output current ( $I_{OUT}$ )  $\times$  diode forward voltage ( $V_F$ ), the diode should be cooled to ensure that its temperature is kept at the value indicated in the catalog or lower.
- Since power loss occurs due to load power and the diode, care should be exercised to ensure that the rated power (Rated output voltage  $\times$  rated output current) for one power supply is not exceeded.
- For backup operation, do not connect the CB and CBG terminals on S8JX-P-series 300-W or 600-W models.

### In Case There Is No Output Voltage

#### S8JX-G Series S8JX-P Series 50-/100-/150-W Models

The possible cause for no output voltage may be that the overcurrent or overvoltage protection has operated. The internal protection may operate if a large amount of surge voltage such as a lightning surge occurs while turning ON the Power Supply.

In case there is no output voltage, please check the following points before contacting us:

- Checking overcurrent protected status:  
Check whether the load is in overcurrent status or is short-circuited. Remove wires to load when checking.
- Checking overvoltage or internal protection:  
Turn the power supply OFF once, and leave it OFF for at least 7 minutes for S8JX-G series and 3 minutes for S8JX-P series. Then turn it ON again to see if this clears the condition.

#### S8JX-P Series 300-/600-W Models

There is a possibility that functions such as over-current protection, over-voltage protection or overheating protection are functioning. In addition, other possible causes include stoppage of the built-in fan and the remote control function (OFF). Please check the following 5 points and, if there is still no output voltage, contact your OMRON sales representative.

#### Method of Checking Over-current Protection

- Check (after removing load line) whether or not the load is in over-current status (including short circuits).

#### Method of Checking Over-voltage Protection

- Switch off the input power supply, and switch back on after at least 3 minutes have elapsed.
- Check whether or not the +S and -S terminals are open.

#### Method of Check Overheating Protection

- Switch off the input power supply and switch back on after allowing sufficient time for cooling.

#### Checking for Built-in Fan Stoppage

- Check whether or not the built-in fan has stopped. The fan is a replaceable component.

#### Checking the Remote Control Function

- Check whether or not the +RC and -RC terminals are in open status. Carry out the regulated connections.

## Switching the AC Input Voltage between 100 and 200 VAC

### S8JX-G Series 150-W, 5-V Models

The input voltage can be switched between 100 V and 200 V by using the input voltage switch. Make the setting shown in the following figure for the voltage that will be used. (The input voltage is factory-set to 200 V.)

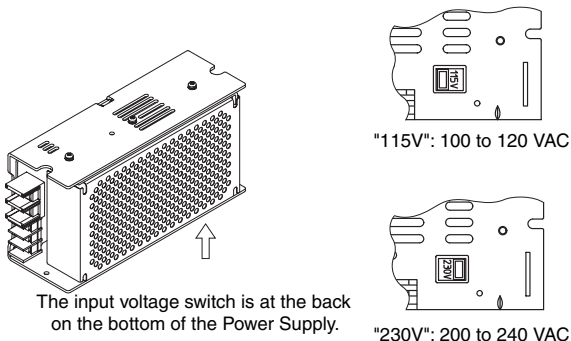

### S8JX-G Series 300-/600-W Models

The input voltage can be switched between 100 and 200 V by shorting or opening the input voltage selection terminals. Set the required voltage as shown below. (The voltage is factory-set to 200 V.)

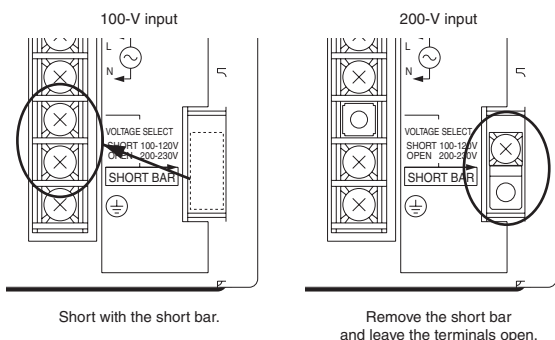

**Note:** A 300-W model is shown above.

## Fan Replacement

### S8JX-G Series 300-W 5V, 12V/600-W Model

The service life of the fan is approximately 50,000 hours (at 25°C). The service life varies, however, depending on the ambient temperature or other surrounding environmental conditions such as dust. As a preventive maintenance measure, replace the fan within approx. two years if it is used at an ambient temperature of 40°C. Purchase the S82Y-JX FAN Replacement Fan (sold separately) to replace the fan.

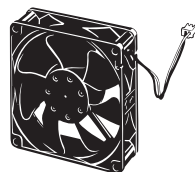

Fan Set:

Fan (above), instruction sheet

Replace the fan as shown in the following illustration.

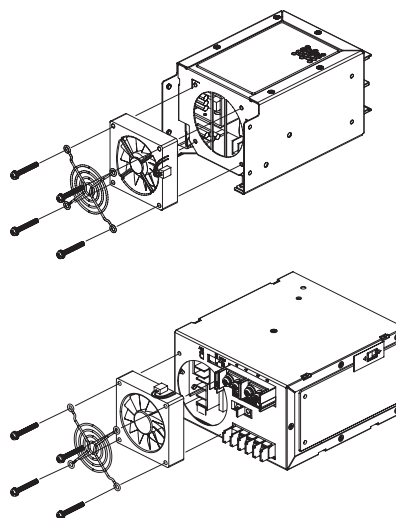

### S8JX-P Series 300-/600-W Models

- Please contact your OMRON sales representative regarding fan replacement. Fans will be replaced at cost. In addition, a replacement fan unit (Model S82Y-JXP□□FAN) is available. Please use the curve below as a guideline for the timing of fan replacement.
- Fan replacements made by the customer fall outside the scope of safety standards.

Replacement should be implemented as shown below.

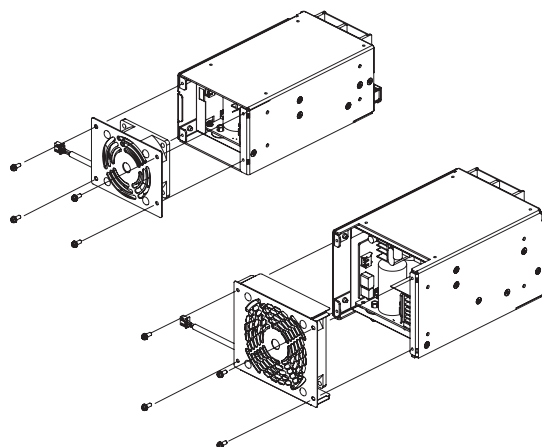

# S8JX

## Typical Values

### For Reference Only S8JX-G Series

Item		Power ratings	15 W	35 W	50 W	100 W	150 W	300 W	600 W	
Efficiency	5-V models		75%	79%	80%	81%	83%	75%	78%	
	12-V models		80%	84%	85%	86%	85%	80%	83%	
	15-V models		80%	84%	---	---	---	---	---	
	24-V models		81%	84%	86%	88%	90%	88%	84%	
	48-V models		80%	84%	86%	89%	91%	88%	85%	
Input	Current	230 V input	0.19 A	0.43 A	0.6 A	1.1 A	2.0 A	3.7 A	6.5 A	
	Leakage current		0.30 mA	0.30 mA	0.35 mA	0.30 mA	0.60 mA	0.7 mA	0.6 mA	
	Inrush current (See Note 1.)		40 A	40 A	40 A	37 A	42 A	35 A	35 A	
Output	Ripple	f = 20 MHz measuring	5-V models	0.35% (p-p)	0.35% (p-p)	0.60% (p-p)	1.25% (p-p)	1.40% (p-p)	0.55% (p-p)	1.80% (p-p)
			12-V models	0.20% (p-p)	0.20% (p-p)	0.30% (p-p)	0.50% (p-p)	1.00% (p-p)	1.10% (p-p)	0.80% (p-p)
			15-V models	0.15% (p-p)	0.15% (p-p)	---	---	---	---	---
			24-V models	0.10% (p-p)	0.15% (p-p)	0.15% (p-p)	0.25% (p-p)	0.45% (p-p)	0.75% (p-p)	0.60% (p-p)
			48-V models	0.05% (p-p)	0.05% (p-p)	0.06% (p-p)	0.12% (p-p)	0.25% (p-p)	0.30% (p-p)	0.75% (p-p)
		f = 100 MHz measuring	5-V models	0.50% (p-p)	0.55% (p-p)	0.75% (p-p)	1.50% (p-p)	1.50% (p-p)	1.90% (p-p)	2.70% (p-p)
			12-V models	0.30% (p-p)	0.35% (p-p)	0.35% (p-p)	0.70% (p-p)	1.25% (p-p)	1.90% (p-p)	1.30% (p-p)
			15-V models	0.20% (p-p)	0.30% (p-p)	---	---	---	---	---
			24-V models	0.20% (p-p)	0.20% (p-p)	0.20% (p-p)	0.40% (p-p)	0.60% (p-p)	1.10% (p-p)	0.60% (p-p)
			48-V models	0.07% (p-p)	0.07% (p-p)	0.08% (p-p)	0.15% (p-p)	0.30% (p-p)	0.45% (p-p)	0.80% (p-p)
	Start up time (See note 1.)	at 100% load	5-V, 12-V, 15-V models	200 ms	200 ms	210 ms	220 ms	250 ms	100 ms	110 ms
			24-V, 48-V models	200 ms	200 ms	210 ms	220 ms	250 ms	350 ms	120 ms
	Hold time (See note 1.)	at 100% load	5-V models	200 ms	200 ms	190 ms	180 ms	54 ms	45 ms	45 ms
			12-V models	200 ms	200 ms	190 ms	170 ms	200 ms	50 ms	50 ms
			15-V models	210 ms	200 ms	---	---	---	---	---
24-V models			200 ms	200 ms	210 ms	170 ms	210 ms	50 ms	50 ms	
48-V models			190 ms	200 ms	200 ms	200 ms	210 ms	50 ms	50 ms	

Note: 1. Refer to the *Engineering Data* on pages 17 to 21 for details.

2. The typical values indicate the values for an input condition of 230 VAC. All items are measured at a frequency of 50 Hz.

### S8JX-P Series

Item		Power ratings	50 W	100 W	150 W	300W	600W		
Efficiency	5-V models		78%	83%	85%	---	---		
	12-V models		81%	84%	85%	---	---		
	24-V models		81%	87%	88%	87.0%	86.6%		
	48-V models		85%	86%	88%	---	---		
Input	Current	230 V input	0.29 A	0.59 A	0.86 A	1.73A	3.42 A		
	Leakage current		0.33 mA	0.59 mA	0.6 mA	0.68 mA	0.68 mA		
	Inrush current (See Note 1.)		33 A	33 A	33 A	29.8 A	31.6 A		
Output	Ripple	f = 20 MHz measuring	5-V models	0.32% (p-p)	1.40% (p-p)	1.32% (p-p)	---	---	
			12-V models	0.22% (p-p)	0.48% (p-p)	0.48% (p-p)	---	---	
			24-V models	0.17% (p-p)	0.36% (p-p)	0.28% (p-p)	0.27% (p-p)	0.20% (p-p)	
			48-V models	0.08% (p-p)	0.21% (p-p)	0.23% (p-p)	---	---	
			f = 100 MHz measuring	5-V models	0.40% (p-p)	1.44% (p-p)	1.48% (p-p)	---	---
		12-V models		0.22% (p-p)	0.50% (p-p)	0.55% (p-p)	---	---	
		24-V models		0.18% (p-p)	0.38% (p-p)	0.31% (p-p)	0.49% (p-p)	0.22% (p-p)	
		48-V models		0.09% (p-p)	0.22% (p-p)	0.23% (p-p)	---	---	
		Start up time (See note 1.)		at 100% load	5-V models	460 ms	370 ms	360 ms	---
			12-V models		460 ms	410 ms	410 ms	---	---
	24-V models		480 ms		410 ms	430 ms	102 ms	70 ms	
	48-V models		500 ms		420 ms	420 ms	---	---	
	Hold time (See note 1.)	at 100% load	5-V models	57 ms	42 ms	37 ms	---	---	
			12-V models	31 ms	34 ms	28 ms	---	---	
			24-V models	34 ms	35 ms	33 ms	34 ms	35.2 ms	
48-V models			44 ms	37 ms	33 ms	---	---		

Note: 1. Refer to the *Engineering Data* on pages 44 to 47 for details.

2. The typical values indicate the values for an input condition of 230 VAC. All items are measured at a frequency of 50 Hz.

ALL DIMENSIONS SHOWN ARE IN MILLIMETERS.

To convert millimeters into inches, multiply by 0.03937. To convert grams into ounces, multiply by 0.03527.

In the interest of product improvement, specifications are subject to change without notice.

## Read and Understand this Catalog

Please read and understand this catalog before purchasing the product. Please consult your OMRON representative if you have any questions or comments.

## Warranty and Limitations of Liability

### WARRANTY

OMRON's exclusive warranty is that the products are free from defects in materials and workmanship for a period of one year (or other period if specified) from date of sale by OMRON.

OMRON MAKES NO WARRANTY OR REPRESENTATION, EXPRESS OR IMPLIED, REGARDING NON-INFRINGEMENT, MERCHANTABILITY, OR FITNESS FOR PARTICULAR PURPOSE OF THE PRODUCTS. ANY BUYER OR USER ACKNOWLEDGES THAT THE BUYER OR USER ALONE HAS DETERMINED THAT THE PRODUCTS WILL SUITABLY MEET THE REQUIREMENTS OF THEIR INTENDED USE. OMRON DISCLAIMS ALL OTHER WARRANTIES, EXPRESS OR IMPLIED.

### LIMITATIONS OF LIABILITY

OMRON SHALL NOT BE RESPONSIBLE FOR SPECIAL, INDIRECT, OR CONSEQUENTIAL DAMAGES, LOSS OF PROFITS, OR COMMERCIAL LOSS IN ANY WAY CONNECTED WITH THE PRODUCTS, WHETHER SUCH CLAIM IS BASED ON CONTRACT, WARRANTY, NEGLIGENCE, OR STRICT LIABILITY.

In no event shall the responsibility of OMRON for any act exceed the individual price of the product on which liability is asserted.

IN NO EVENT SHALL OMRON BE RESPONSIBLE FOR WARRANTY, REPAIR, OR OTHER CLAIMS REGARDING THE PRODUCTS UNLESS OMRON'S ANALYSIS CONFIRMS THAT THE PRODUCTS WERE PROPERLY HANDLED, STORED, INSTALLED, AND MAINTAINED AND NOT SUBJECT TO CONTAMINATION, ABUSE, MISUSE, OR INAPPROPRIATE MODIFICATION OR REPAIR.

## Application Considerations

### SUITABILITY FOR USE

OMRON shall not be responsible for conformity with any standards, codes, or regulations that apply to the combination of products in the customer's application or use of the products.

Take all necessary steps to determine the suitability of the product for the systems, machines, and equipment with which it will be used.

Know and observe all prohibitions of use applicable to this product.

NEVER USE THE PRODUCTS FOR AN APPLICATION INVOLVING SERIOUS RISK TO LIFE OR PROPERTY WITHOUT ENSURING THAT THE SYSTEM AS A WHOLE HAS BEEN DESIGNED TO ADDRESS THE RISKS, AND THAT THE OMRON PRODUCTS ARE PROPERLY RATED AND INSTALLED FOR THE INTENDED USE WITHIN THE OVERALL EQUIPMENT OR SYSTEM.

### PROGRAMMABLE PRODUCTS

OMRON shall not be responsible for the user's programming of a programmable product, or any consequence thereof.

## Disclaimers

### CHANGE IN SPECIFICATIONS

Product specifications and accessories may be changed at any time based on improvements and other reasons.

It is our practice to change model numbers when published ratings or features are changed, or when significant construction changes are made. However, some specifications of the products may be changed without any notice. When in doubt, special model numbers may be assigned to fix or establish key specifications for your application on your request. Please consult with your OMRON representative at any time to confirm actual specifications of purchased products.

### DIMENSIONS AND WEIGHTS

Dimensions and weights are nominal and are not to be used for manufacturing purposes, even when tolerances are shown.

### PERFORMANCE DATA

Performance data given in this catalog is provided as a guide for the user in determining suitability and does not constitute a warranty. It may represent the result of OMRON's test conditions, and the users must correlate it to actual application requirements. Actual performance is subject to the OMRON Warranty and Limitations of Liability.

**OMRON Corporation** Industrial Automation Company  
Tokyo, JAPAN

Contact: [www.ia.omron.com](http://www.ia.omron.com)

**Regional Headquarters**

**OMRON EUROPE B.V.**  
Wegalaan 67-69-2132 JD Hoofddorp  
The Netherlands  
Tel: (31)2356-81-300/Fax: (31)2356-81-388

**OMRON ASIA PACIFIC PTE. LTD.**  
No. 438A Alexandra Road # 05-05/08 (Lobby 2),  
Alexandra Technopark,  
Singapore 119967  
Tel: (65) 6835-3011/Fax: (65) 6835-2711

**OMRON ELECTRONICS LLC**  
One Commerce Drive Schaumburg,  
IL 60173-5302 U.S.A.  
Tel: (1) 847-843-7900/Fax: (1) 847-843-7787

**OMRON (CHINA) CO., LTD.**  
Room 2211, Bank of China Tower,  
200 Yin Cheng Zhong Road,  
PuDong New Area, Shanghai, 200120, China  
Tel: (86) 21-5037-2222/Fax: (86) 21-5037-2200

Authorized Distributor:

© OMRON Corporation 2009 All Rights Reserved.  
In the interest of product improvement,  
specifications are subject to change without notice.

CSM\_3\_9\_0216  
Cat. No. T042-E1-06

Printed in Japan  
1111