

New!

OMRON



Programmable Controllers

SYSMAC CS/CJ Series

Controllers for Gradient Temperature Control

CJ1G-CPU45P-GTC Loop-control CPU Unit

CS1W-LCB05-GTC Loop Control Board

Loop Controllers with Fully Integrated Sequence and Loop Control and Built-in Gradient Algorithms for Planar Temperature Control Across Multiple Points

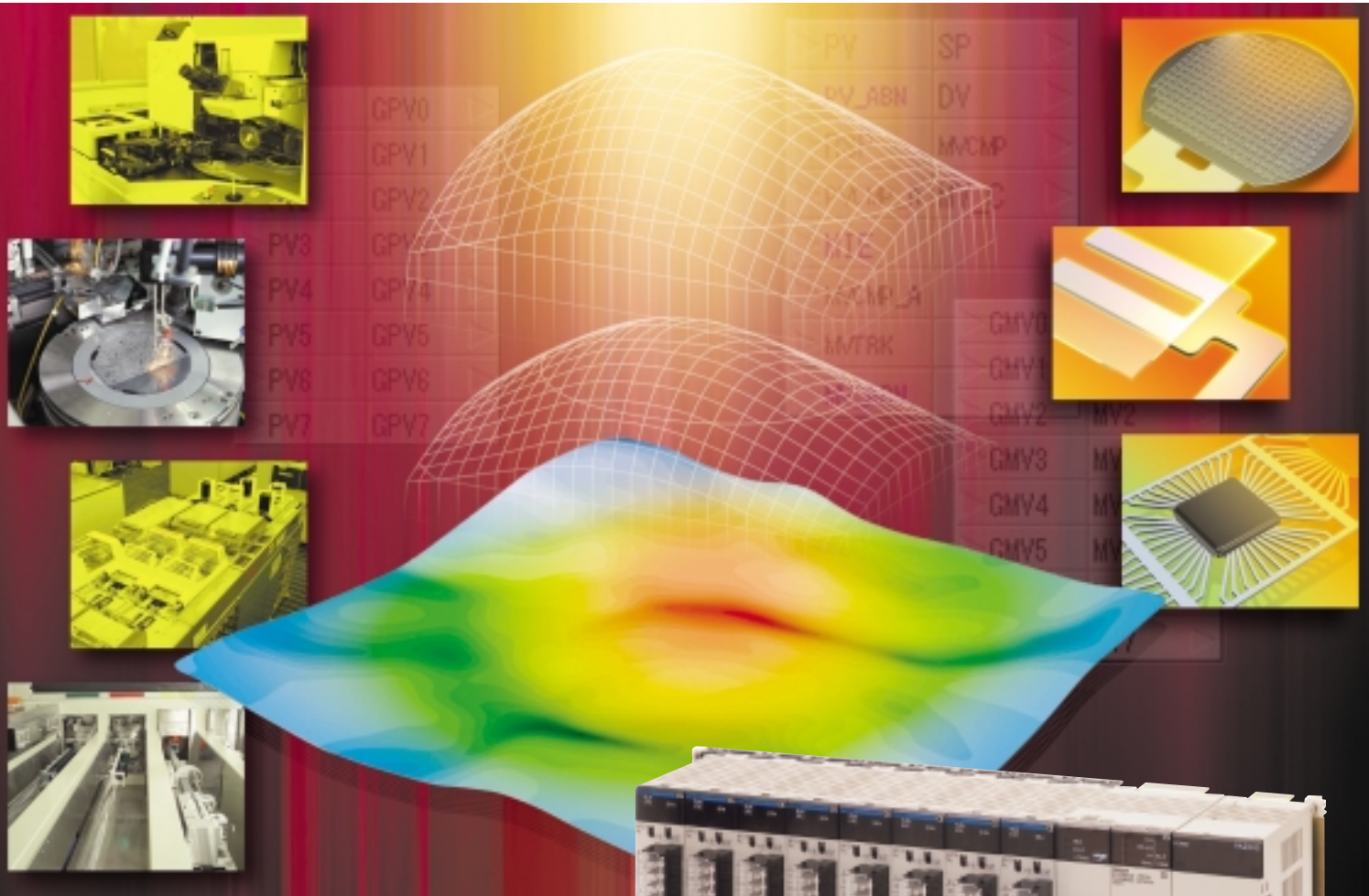
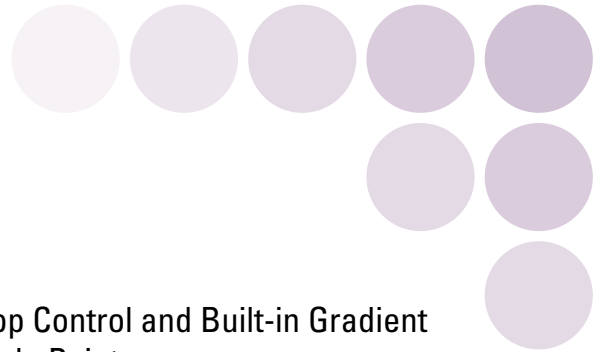

realizing



And now a gradient temperature control algorithm has been built into a Loop Controller to support a wide variety of applications. Uniform temperature control is now possible across multiple points for increased product quality.

Gradient Temperature Control for Planar Temperature Control Across Multiple Points

Inconsistent thermal processing temperatures result in unstable workpieces and reduced yield. OMRON's unique Gradient Temperature Control technology enables planar control of thermal processing temperatures. This not only increases the quality of thermal processing, but also reduces energy loss while the temperature stabilizes and the adjustment time required to eliminate interference caused by heaters. This has a great impact on batch ovens, glass substrate hot plates, and other precise process control.

Greater Quality with Planar Temperature Control

Both planar control and user-defined profile are possible.

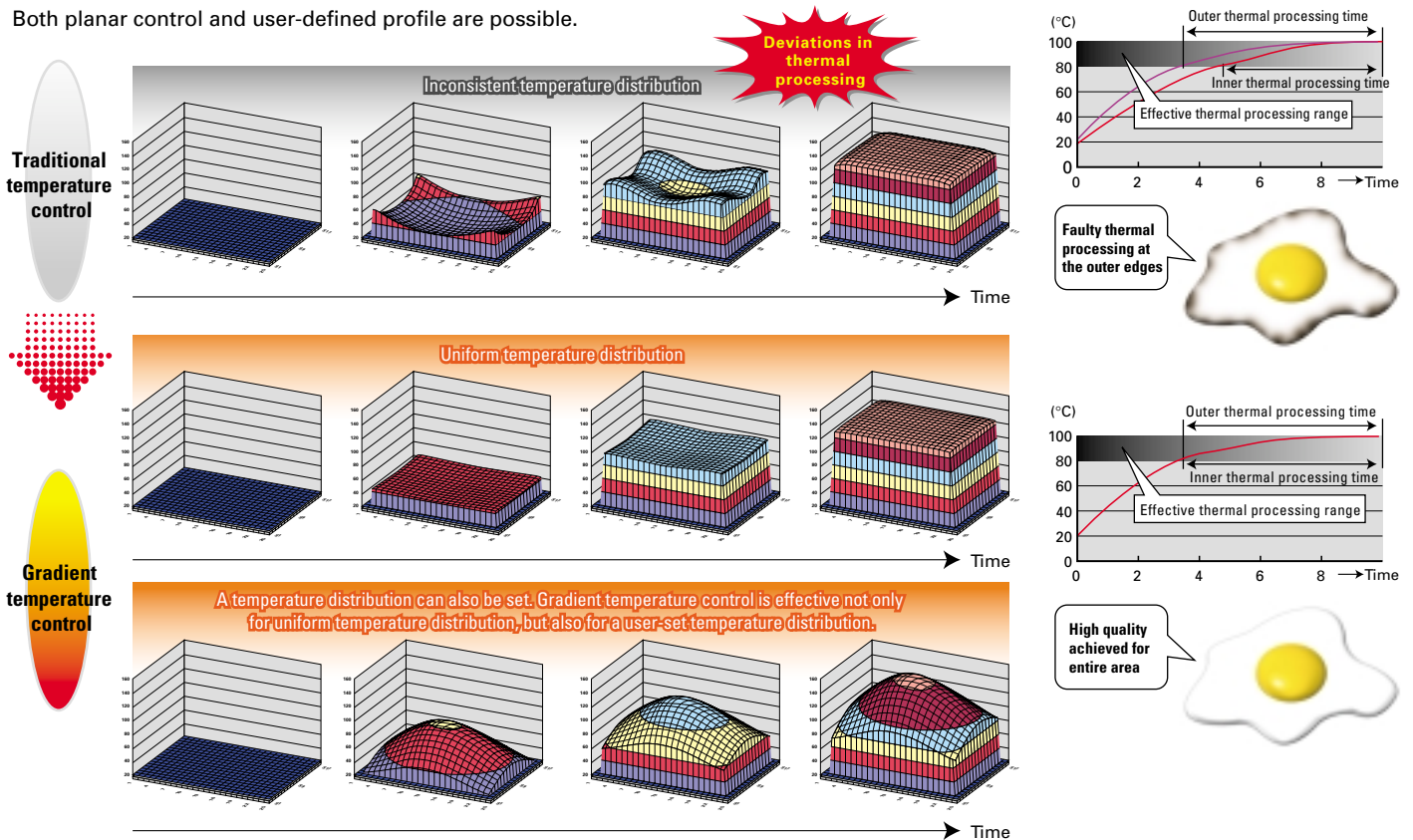

What is Gradient Temperature Control?

Gradient temperature control is a control method that achieves a uniform temperature or preset temperature profile over a 2D surface. An example application would be multi-point control of surface temperature using multiple heaters. The gradient temperature control algorithm directly controls the average temperature of all points as well as the temperature difference between each pair of points. The algorithm also includes methods to eliminate the interference of each control output on the other control points.

When temperature inputs are received, the average temperature of all points and the temperature differences between each pair of points are calculated. PID control is performed for the present value (PV) of each of these control points. In addition, PID output values are distributed to prevent them from affecting PID control performance at other points, thus eliminating interference. This means that the interference of heaters on other control points is reduced to enable uniform in-plane temperature control.

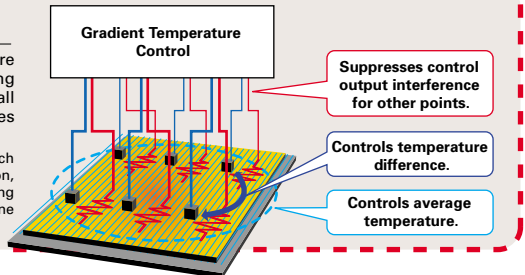

Example Applications

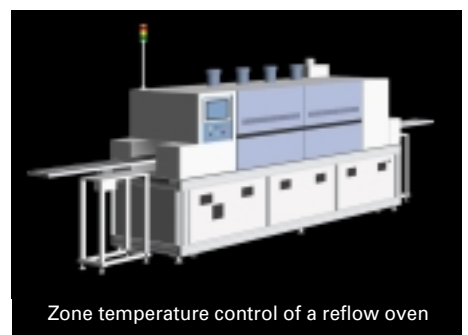
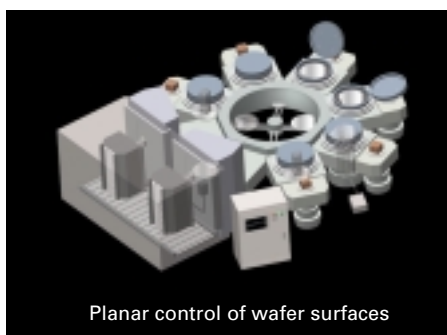
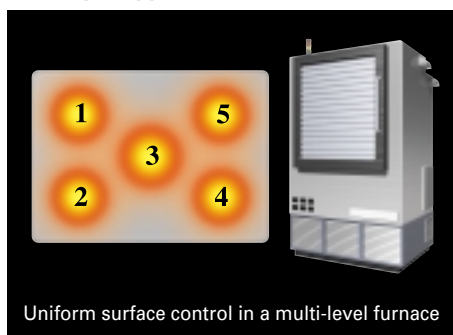

Gradient Temperature Control Mechanism and Programming Examples

Gradient temperature control finds and controls the relationship between temperatures for mutually interfering points, i.e., it finds the average temperature and the gradient temperatures, which are the temperature differences between points. This type of control achieves uniform in-plan temperatures.

Control Block Diagram

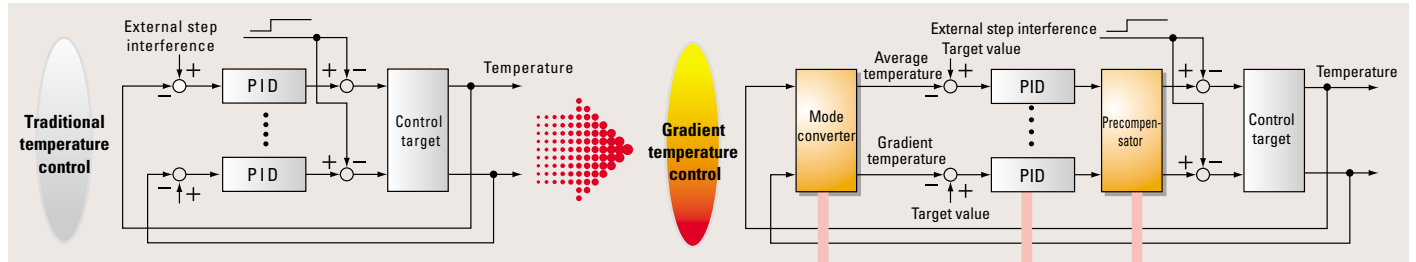

System Configuration Example

6-point Gradient Temperature Control

- One CJ1G-CPU45P-GTC Loop Controller with Gradient Temperature Control
- Two CJ1W-PTS51 Temperature Sensor Units (4-point Thermocouple Input Units)
- Controlling Thyristors Using Current Output (Continuous Proportional)
One CJ1W-DA08C Analog Output Unit (8-point)

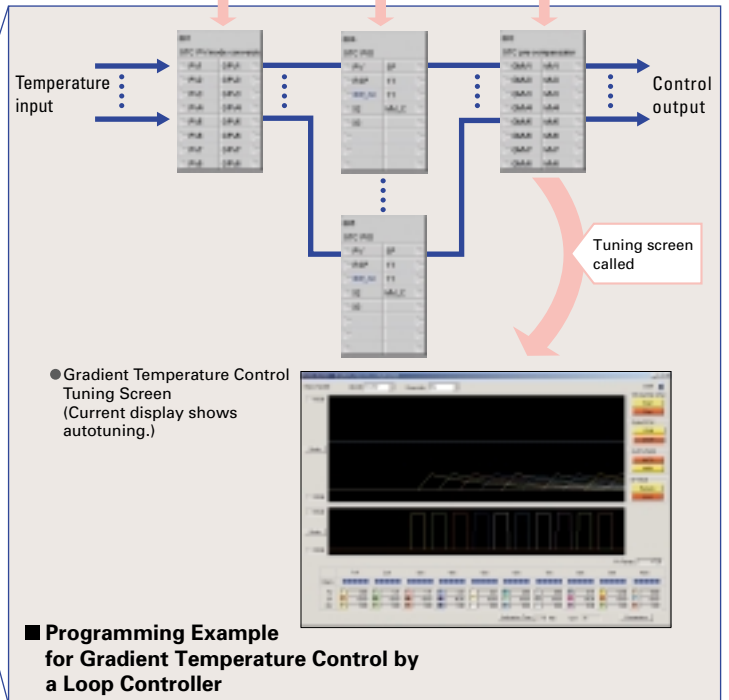
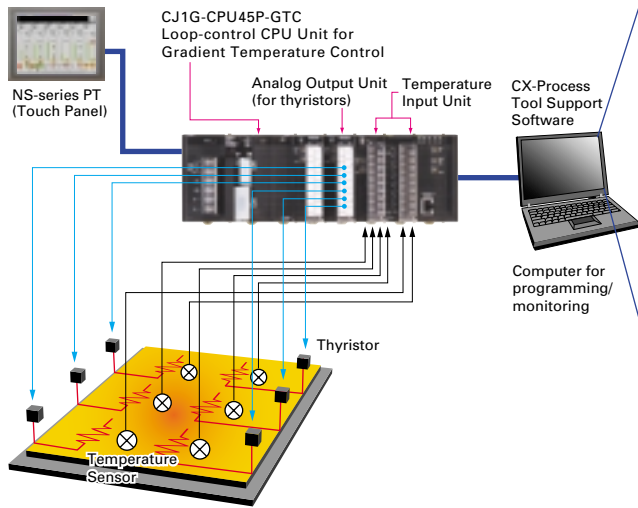

Note: Real programs require gradient SP mode conversion blocks to input settings to each PID block.

Features of Gradient Temperature Control by Loop Controllers

Loop Controllers can perform gradient temperature control by combining gradient PV mode conversion, gradient SP mode conversion, gradient PID, and gradient precompensator function blocks.

- Gradient temperature control of up to 10 points/group is possible. More than one group can be used by combining function blocks.
- The gradient precompensator and gradient PID parameters can be tuned using gradient temperature control autotuning to eliminate interference.
- Fast minimum operation cycle of 10 ms (for one group).

OMRON Controllers with Gradient Temperature Control

Select the best combination for the application.

PLC Units



Wide range of products for process and analog I/O, including High-density Units. Perfect for large- and medium-scale process equipment.

SYMAC CS1 Loop Control Board
CS1W-LCB05-GTC

This Loop Control Board is for gradient temperature control using a CS-series PLC. It is installed in CPU Unit as an Inner Board.



Flexible system configuration with a Backplane-free construction. Perfect for minimum size installations.

SYMAC CJ1 Loop-control CPU Unit
CJ1G-CPU45P-GTC

This CPU Unit is for loop gradient temperature control using a CJ-series PLC. It provides loop control functions and hybrid control, including sequence control.

Temperature Controllers



Modular Temperature Controller
E1 for Gradient Temperature Control

This new style Modular Temperature Controller improves machine performance from design and installation through maintenance by reducing programming time with program-less communications with PLCs and one-step installation on DIN Track.

Note: Refer to Cat. No. H144 for details on the E1.

■ Main Loop Controller Specifications

CJ-series Loop Controllers are available for process control devices and CS-series Loop Controllers are available for devices requiring high-density control.

Model		CJ1G-CPU45P-GTC	CS1W-LCB05-GTC
Series		CJ Series	CS Series
CPU configuration		One Unit with both sequence control and loop control CPUs	Mounted in CS-series CPU Unit as an Inner Board.
Processing method	Loop control	Function blocks (with step ladder blocks)	Function blocks (with step ladder and sequence table blocks)
	Sequence control	Ladder diagrams, function blocks, standard text (60 Ksteps)	None (Used together with a CS-series CPU Unit.)
No. of function blocks in the loop control section		300 blocks max.	500 blocks max.
No. of gradient temperature control points per group		10	
Operation cycle		Supported cycle settings: 0.01, 0.02, 0.05, 0.1, 0.2, 0.5, 1, and 2 s Note: 0.01, 0.02, and 0.05 s cannot be set for some blocks.	
Programming Software		CX-One (Loop control: CX-Process Tool; Sequence control: CX-Programmer, etc.)	

■ Ordering Information

Product name	Specification						Model
	External I/O capacity	Program capacity	Data memory capacity	LD instruction execution time	Number of function blocks	Gradient temperature control	
CJ-series Loop-control CPU Unit	1,280 points (Up to 3 Expansion Racks)	60 Ksteps	128 Kwords (DM: 32 Kwords, EM: 32 Kwords x 3 banks)	0.04 μs	300 blocks	Possible (10 points/group)	CJ1G-CPU45P-GTC
CS-series Loop Control Board (LCB)					500 blocks	Possible (10 points/group)	CS1W-LCB05-GTC

Warranty and Limitations of Liability

WARRANTY

OMRON's exclusive warranty is that the products are free from defects in materials and workmanship for a period of one year (or other period if specified) from date of sale by OMRON.

OMRON MAKES NO WARRANTY OR REPRESENTATION, EXPRESS OR IMPLIED, REGARDING NON-INFRINGEMENT, MERCHANTABILITY, OR FITNESS FOR PARTICULAR PURPOSE OF THE PRODUCTS. ANY BUYER OR USER ACKNOWLEDGES THAT THE BUYER OR USER ALONE HAS DETERMINED THAT THE PRODUCTS WILL SUITABLY MEET THE REQUIREMENTS OF THEIR INTENDED USE. OMRON DISCLAIMS ALL OTHER WARRANTIES, EXPRESS OR IMPLIED.

LIMITATIONS OF LIABILITY

OMRON SHALL NOT BE RESPONSIBLE FOR SPECIAL, INDIRECT, OR CONSEQUENTIAL DAMAGES, LOSS OF PROFITS, OR COMMERCIAL LOSS IN ANY WAY CONNECTED WITH THE PRODUCTS, WHETHER SUCH CLAIM IS BASED ON CONTRACT, WARRANTY, NEGLIGENCE, OR STRICT LIABILITY.

In no event shall the responsibility of OMRON for any act exceed the individual price of the product on which liability is asserted.

IN NO EVENT SHALL OMRON BE RESPONSIBLE FOR WARRANTY, REPAIR, OR OTHER CLAIMS REGARDING THE PRODUCTS UNLESS OMRON'S ANALYSIS CONFIRMS THAT THE PRODUCTS WERE PROPERLY HANDLED, STORED, INSTALLED, AND MAINTAINED AND NOT SUBJECT TO CONTAMINATION, ABUSE, MISUSE, OR INAPPROPRIATE MODIFICATION OR REPAIR.

Note: Do not use this document to operate the Unit.

Printed on 100%
Recycled Paper



OMRON Corporation

Industrial Automation Company Control Devices Division H.Q.

Shiokoji Horikawa, Shimogyo-ku,
Kyoto, 600-8530 Japan
Tel: (81)75-344-7109
Fax: (81)75-344-7149

Regional Headquarters

OMRON EUROPE B.V.

Wegalaan 67-69, NL-2132 JD Hoofddorp
The Netherlands
Tel: (31)2356-81-300/
Fax: (31)2356-81-388

OMRON ELECTRONICS LLC

1 East Commerce Drive, Schaumburg,
IL 60173 U.S.A.
Tel: (1)847-843-7900/Fax: (1)847-843-8568

OMRON ASIA PACIFIC PTE. LTD.

83 Clemenceau Avenue,
#11-01, UE Square,
Singapore 239920
Tel: (65)6835-3011/Fax: (65)6835-2711

OMRON (CHINA) CO., LTD.

Room 2211, Bank of China Tower,
200 Yin Cheng Zhong Road,
PuDong New Area, Shanghai, 200120 China
Tel: (86)21-5037-2222/Fax: (86)21-5037-2200

Authorized Distributor:

Note: Specifications subject to change without notice.

Cat. No. R141-E1-02
Printed in Japan
1006-1M