

Machine Automation Controller
Industrial PC Platform

NX/NY-series

Artificial Intelligence Machine Automation Controller

User's Manual

NX701-Z□□□

NY532-Z□□□

NY512-Z□□□



CPU Unit



NOTE

- All rights reserved. No part of this publication may be reproduced, stored in a retrieval system, or transmitted, in any form, or by any means, mechanical, electronic, photocopying, recording, or otherwise, without the prior written permission of OMRON.
- No patent liability is assumed with respect to the use of the information contained herein. Moreover, because OMRON is constantly striving to improve its high-quality products, the information contained in this manual is subject to change without notice.
- Every precaution has been taken in the preparation of this manual. Nevertheless, OMRON assumes no responsibility for errors or omissions. Neither is any liability assumed for damages resulting from the use of the information contained in this publication.

Trademarks

- Sysmac and SYSMAC are trademarks or registered trademarks of OMRON Corporation in Japan and other countries for OMRON factory automation products.
- Microsoft, Windows, Excel, and Visual Basic are either registered trademarks or trademarks of Microsoft Corporation in the United States and other countries.
- EtherCAT® is registered trademark and patented technology, licensed by Beckhoff Automation GmbH, Germany.
- ODVA, CIP, CompoNet, DeviceNet, and EtherNet/IP are trademarks of ODVA.
- The SD and SDHC logos are trademarks of SD-3C, LLC.  

Other company names and product names in this document are the trademarks or registered trademarks of their respective companies.

Copyrights

- Microsoft product screen shots reprinted with permission from Microsoft Corporation.
- This product incorporates certain third party software. The license and copyright information associated with this software is available at http://www.fa.omron.co.jp/nj_info_e/.

Introduction

Thank you for purchasing an NX/NY-series Artificial Intelligence Machine Automation Controller. This manual contains information that is necessary to use the NX/NY-series Artificial Intelligence Machine Automation Controller. Please read this manual and make sure you understand the functionality and performance before you attempt to use it in a control system.

Keep this manual in a safe place where it will be available for reference during operation.

This manual only describes functions that are added to NX701-Z□□□, NY532-Z□□□, and NY512-Z□□□.

When you use NX701-Z□□□, also consult manuals for the NX-series listed in *Related Manuals* on page 24 for functions common to the NX-series CPU Units.

When you use NY532-Z□□□ or NY512-Z□□□, also consult manuals for the NY-series listed in *Related Manuals* on page 24 for functions common to the NY-series Industrial PC.

Intended Audience

This manual is intended for the following personnel, who must also have knowledge of electrical systems (an electrical engineer or the equivalent).

- Personnel in charge of introducing FA systems.
- Personnel in charge of designing FA systems.
- Personnel in charge of installing and maintaining FA systems.
- Personnel in charge of managing FA systems and facilities.

For programming, this manual is intended for personnel who understand the programming language specifications in international standard IEC 61131-3 or Japanese standard JIS B 3503 and those who have expertise in AI technology.

Applicable Products

This manual covers the following products.

- NX-series Artificial Intelligence CPU Unit
 - a) NX701-Z700
 - b) NX701-Z600
- NY-series Artificial Intelligence Industrial PC
 - a) NY532-Z500
 - b) NY532-Z400
 - c) NY532-Z300
 - d) NY512-Z500
 - e) NY512-Z400
 - f) NY512-Z300

Relevant Manuals

The following table provides the relevant manuals for the NX/NY-series Controllers. Read all of the manuals that are relevant to your system configuration and application before you use the NX/NY-series Controllers.

Most operations are performed from the Sysmac Studio Automation Software. Refer to the *Sysmac Studio Version 1 Operation Manual (Cat. No. W504)* for information on the Sysmac Studio.

Relevant Manuals for NX Series

Purpose of use	Manual										
	Basic information			NJ/NX-series Motion Control Instructions Reference Manual	NJ/NX-series Motion Control User's Manual	NJ/NX-series CPU Unit Built-in EtherCAT Port User's Manual	NJ/NX-series CPU Unit Built-in EtherNet/IP Port User's Manual	NX-series CPU Unit FINS Functions User's Manual	NJ/NX-series Database Connection CPU Units User's Manual	NX/NY-series Artificial Intelligence Machine Automation Controller User's Manual	NJ/NX-series Troubleshooting Manual
	NX-series CPU Unit Hardware User's Manual	NJ/NX-series CPU Unit Software User's Manual	NJ/NX-series Instructions Reference Manual								
Introduction to NX701 CPU Units	<input type="radio"/>										
Setting devices and hardware	<input type="radio"/>			<input type="radio"/>		<input type="radio"/>	<input type="radio"/>				
Using motion control											
Using EtherCAT											
Using EtherNet/IP											
Using the database connection service								<input type="radio"/>			
Using AI functions									<input type="radio"/>		
Software settings	<input type="radio"/>										
Using motion control				<input type="radio"/>							
Using EtherCAT						<input type="radio"/>					
Using EtherNet/IP							<input type="radio"/>				
Using FINS								<input type="radio"/>			
Using the database connection service									<input type="radio"/>		
Using AI functions									<input type="radio"/>		

Purpose of use	Manual										
	Basic information			NJ/NX-series Motion Control User's Manual	NJ/NX-series Motion Control Instructions Reference Manual	NJ/NX-series CPU Unit Built-in EtherCAT Port User's Manual	NJ/NX-series CPU Unit Built-in EtherNet/IP Port User's Manual	NX-series CPU Unit FINS Functions User's Manual	NJ/NX-series Database Connection CPU Units User's Manual	NX/NY-series Artificial Intelligence Machine Automation Controller User's Manual	NJ/NX-series Troubleshooting Manual
	NX-series CPU Unit Hardware User's Manual	NJ/NX-series CPU Unit Software User's Manual	NJ/NX-series Instructions Reference Manual								
Writing the user program											
Using motion control				○	○						
Using EtherCAT						○					
Using EtherNet/IP							○				
Using FINS		○	○					○			
Using the database connection service									○		
Using AI functions										○	
Programming error processing											○
Testing operation and debugging											
Using motion control				○							
Using EtherCAT						○					
Using EtherNet/IP							○				
Using FINS		○						○			
Using the database connection service									○		
Using AI functions										○	
Learning about error management and corrections*1								△	△	△	○
Maintenance											
Using motion control	○			○							
Using EtherCAT						○					
Using EtherNet/IP							○				

*1. Refer to the *NJ/NX-series Troubleshooting Manual (Cat. No. W503)* for the error management concepts and an overview of the error items. However, refer to the manuals that are indicated with triangles (△) for details on errors corresponding to the products with the manuals that are indicated with triangles (△).

Relevant Manuals for NY Series

Purpose of use	Manual												
	Basic information												
	NY-series IPC Machine Controller Industrial Panel PC / Industrial Box PC Setup User's Manual	NY-series IPC Machine Controller Industrial Box PC Hardware User's Manual	NY-series IPC Machine Controller Industrial Panel PC / Industrial Box PC	NY-series IPC Machine Controller Industrial Panel PC / Industrial Box PC Software User's Manual	NY-series Instructions Reference Manual	NY-series IPC Machine Controller Industrial Panel PC / Industrial Box PC Motion Control User's Manual	NY-series Motion Control Instructions Reference Manual	NY-series IPC Machine Controller Industrial Panel PC / Industrial Box PC Built-in EtherNet/IP Port User's Manual	NY-series IPC Machine Controller Industrial Panel PC / Industrial Box PC Built-in EtherCAT Port User's Manual	NU/NY-series NC Integrated Controller User's Manual	NX/NY-series Artificial Intelligence Machine Automation Controller User's Manual	NY-series Troubleshooting Manual	
Introduction to NY-series Panel PCs	○												
Introduction to NY-series Box PCs		○											
Setting devices and hardware	○	○			○		○						
Using motion control													
Using EtherCAT										○			
Using AI functions												○	
Making setup*1			○										
Making initial settings				○									
Preparing to use Controllers													
Software settings				○			○						
Using motion control													
Using EtherCAT									○				
Using EtherNet/IP										○			
Using numerical control											○		
Using AI functions											○		
Writing the user program				○	○								
Using motion control								○	○				
Using EtherCAT										○			
Using EtherNet/IP											○		
Using numerical control												○	
Using AI functions													○
Programming error processing												○	

Purpose of use	Manual										
	Basic information					NY-series IPC Machine Controller Industrial Panel PC / Industrial Box PC Software User's Manual	NY-series IPC Machine Controller Industrial Panel PC / Industrial Box PC Motion Control User's Manual	NY-series Instructions Reference Manual	NY-series G code Instructions Reference Manual	NJ/NY-series NC Integrated Controller User's Manual	NX/NY-series Artificial Intelligence Machine Automation Controller User's Manual
	NY-series IPC Machine Controller Industrial Box PC Hardware User's Manual	NY-series IPC Machine Controller Industrial Panel PC Hardware User's Manual	NY-series IPC Machine Controller Industrial Panel PC / Industrial Box PC Setup User's Manual	NY-series IPC Machine Controller Industrial Panel PC / Industrial Box PC Software User's Manual	NY-series Instructions Reference Manual						
Testing operation and debugging											
Using motion control						○					
Using EtherCAT				○							
Using EtherNet/IP								○			
Using numerical control									○		
Using AI functions										○	
Learning about error management and corrections*2									△	△	○
Maintenance											
Using motion control	○	○				○					
Using EtherCAT								○			
Using EtherNet/IP									○		

*1. Refer to the *NY-series Industrial Panel PC / Industrial Box PC Setup User's Manual (Cat.No. W568)* for how to set up and how to use the utilities on Windows.

*2. Refer to the *NJ/NX-series Troubleshooting Manual (Cat. No. W503)* for the error management concepts and an overview of the error items. However, refer to the manuals that are indicated with triangles (△) for details on errors corresponding to the products with the manuals that are indicated with triangles (△).

Manual Structure

Page Structure

The following page structure is used in this manual.

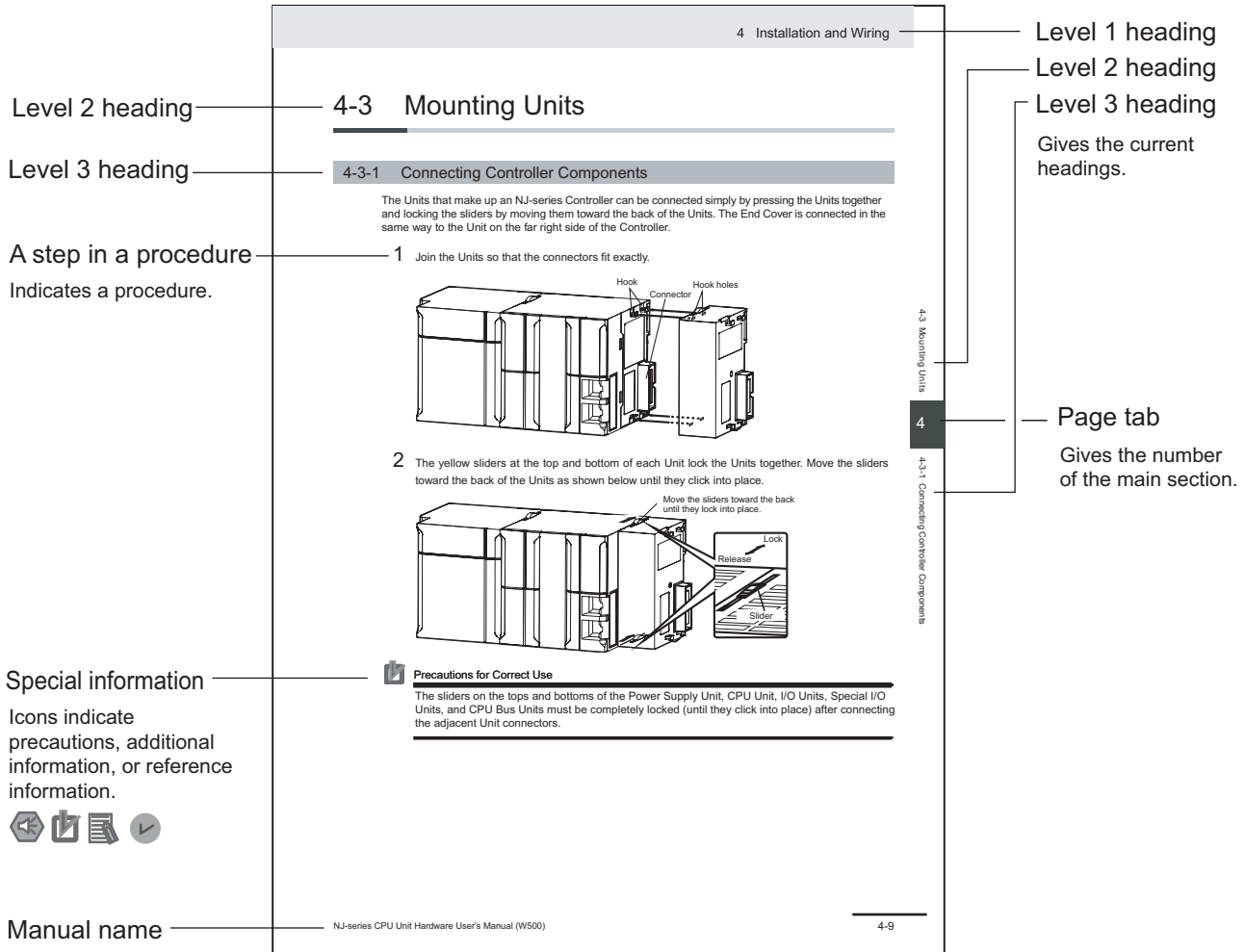

This illustration is provided only as a sample. It may not literally appear in this manual.

Special Information

Special information in this manual is classified as follows:



Precautions for Safe Use

Precautions on what to do and what not to do to ensure safe usage of the product.



Precautions for Correct Use

Precautions on what to do and what not to do to ensure proper operation and performance.



Additional Information

Additional information to read as required.

This information is provided to increase understanding or make operation easier.



Version Information

Information on differences in specifications and functionality for Controller with different unit versions and for different versions of the Sysmac Studio is given.

Precaution on Terminology

- In this manual, *download* refers to transferring data from the Sysmac Studio to the physical Controller, and *upload* refers to transferring data from the physical Controller to the Sysmac Studio. For the Sysmac Studio, *synchronization* is used to both *upload* and *download* data. Here, *synchronize* means to automatically compare the data for the Sysmac Studio on the computer with the data in the physical Controller and transfer the data in the direction that is specified by the user.
- Some of the instructions described in this manual apply to both the NX and NY-series Controllers. Therefore, note the following conditions.
 - a) NX-series enables you to connect a computer that runs the Support Software directly to the CPU Unit with a USB connection. However, NY-series has no peripheral USB port. For details, refer to the *NJ/NX-series CPU Unit Software User's Manual (Cat. No. W501)* or the *NY-series Industrial Panel PC / Industrial Box PC Software User's Manual (Cat. No. W558)*.
 - b) In this manual, the *SD Memory Card* refers to storage used by AI functions. Note that SD Memory Cards inserted to the SD Memory Card slots of NY-series Controllers are for use by Windows and do not use for AI functions. For details on SD Memory Cards of NY-series Controllers, refer to the *NY-series Industrial Box PC Hardware User's Manual (Cat. No. W556)* or the *NY-series Industrial Panel PC Hardware User's Manual (Cat. No. W557)*.

Sections in this Manual

1	Overview and Features	A	Appendices	1	A
2	Time Series Database Function	I	Index	2	I
3	Feature Value/Machine Learning Function			3	
4	WebAPI Connection Function			4	
5	Time Series Database Instructions			5	
6	Startup Procedures for the AI Controller			6	
7	Maintenance			7	
8	Troubleshooting			8	
9	AI Predictive Maintenance Library			9	

CONTENTS

Introduction	1
Intended Audience	1
Applicable Products	1
Relevant Manuals	2
Relevant Manuals for NX Series	2
Relevant Manuals for NY Series	4
Manual Structure	6
Page Structure	6
Special Information	6
Precaution on Terminology	7
Sections in this Manual	9
Terms and Conditions Agreement	14
Warranty, Limitations of Liability	14
Application Considerations	15
Disclaimers	15
Safety Precautions	17
Definition of Precautionary Information	17
Symbols	17
WARNING	17
Precautions for Safe Use	19
Precautions for Correct Use	20
Regulations and Standards	21
Software Licenses and Copyrights	21
Versions	22
Checking Versions	22
Related Manuals	24
Terminology	27
Revision History	29

Section 1 Overview and Features

1-1 Overview	1-2
1-2 Features	1-3
1-3 System Configuration	1-5
1-4 Functional Configurations Related to the AI Controller	1-6
1-4-1 AI Controller Function	1-7
1-4-2 AI Controller Software	1-8
1-4-3 Types of Data	1-10
1-5 Overview of Operating Procedures	1-11

1-5-1	Data Collection/Data Analysis/Data Utilization.....	1-11
1-5-2	Relationship between AI Functions and Phases.....	1-11
1-5-3	Relationship between AI Controller Software and Phases.....	1-12
1-6	List of Models.....	1-13

Section 2 Time Series Database Function

2-1	Function Overview.....	2-2
2-2	Collected Data.....	2-4
2-2-1	Types of Collected Data.....	2-4
2-2-2	Collection Timing.....	2-4
2-3	TSDB Service Status.....	2-5
2-3-1	Status.....	2-5
2-3-2	Checking Method.....	2-5
2-3-3	Change Method.....	2-6
2-4	How to Start and Stop Sampling and Export.....	2-7
2-5	List of Settings.....	2-8
2-6	Statistical Information.....	2-9
2-7	Restrictions.....	2-10

Section 3 Feature Value/Machine Learning Function

3-1	Function Overview.....	3-2
3-1-1	Frames and Subframes.....	3-2
3-1-2	Input Data for the Feature Value/Machine Learning Function.....	3-3
3-1-3	Output Data for the Feature Value/Machine Learning Function.....	3-3
3-1-4	AI Machine Learning Model.....	3-4
3-2	Details on Function.....	3-5
3-2-1	I/O Data.....	3-6
3-2-2	I/O data Timing.....	3-9
3-2-3	Data Structures.....	3-10
3-3	Status of the Feature Value/Machine Learning Function.....	3-11
3-3-1	Status.....	3-11
3-3-2	Checking Method.....	3-12
3-3-3	Change Method.....	3-12
3-4	General Specifications.....	3-14
3-5	Calculation Timing.....	3-15
3-6	Restrictions.....	3-16

Section 4 WebAPI Connection Function

4-1	Function Overview.....	4-2
4-2	Status of the WebAPI Connection Service.....	4-4
4-2-1	Status.....	4-4
4-2-2	Checking Method.....	4-4
4-2-3	Change Method.....	4-4
4-3	File Transfer Execution Method.....	4-5
4-4	How to Import Certificates.....	4-6
4-5	Web Server Connection Check Function.....	4-7
4-5-1	Function Specifications.....	4-7
4-5-2	Application Method.....	4-7

4-6	Operation Processing of the WebAPI Connection Service	4-8
4-7	File Transfer Results	4-9
4-7-1	Transfer Results	4-9
4-7-2	Statistical Information	4-9
4-8	List of Settings	4-11
4-9	Restrictions	4-13

Section 5 Time Series Database Instructions

TimeSeries_ControlService	5-2
Variables	5-2
Function	5-2
Related System-defined Variables.....	5-2
Precautions for Correct Use	5-3
Additional Information	5-3
Sample Programming	5-3
TimeSeries_ControlSampling	5-6
Variables	5-6
Function	5-6
Related System-defined Variables.....	5-7
Precautions for Correct Use	5-7
TimeSeries_ControlExport	5-8
Variables	5-8
Function	5-9
Related System-defined Variables.....	5-9
Precautions for Correct Use	5-9

Section 6 Startup Procedures for the AI Controller

6-1	Overview of Startup Procedures	6-2
6-2	Preliminary Preparation Phase	6-6
6-3	Data Collection Phase	6-8
6-4	Data Analysis Phase	6-14
6-5	Data Utilization Phase	6-15
6-6	Using Extension Function	6-25
6-6-1	WebAPI Connection Function	6-25
6-6-2	Variable Data Collection	6-28

Section 7 Maintenance

7-1	Introduction	7-2
7-2	Data That Is Backed Up and Compatibility Between the Models	7-3
7-2-1	Backup Data (NX701-Z□00 and NY5□2-Z□00).....	7-3
7-2-2	Compatibility between the Models (NX701-Z□00 and NY5□2-Z□00).....	7-4
7-2-3	Compatibility between the Unit Versions (NX701-Z□00 and NY5□2-Z□00)	7-4
7-3	Storage Replacement	7-5
7-3-1	Storage Replacement Timing	7-5
7-3-2	Data Saved in the Storage	7-5
7-3-3	Replacement Procedure	7-6
7-3-4	Checking Operation After Replacement (NX701-Z□00, NY5□2-Z□00).....	7-8

Section 8 Troubleshooting

8-1 Overview of Errors	8-2
8-1-1 How to Check for Errors.....	8-2
8-1-2 Errors Related to the AI Functions.....	8-4
8-2 Troubleshooting	8-7
8-2-1 Error Table.....	8-7
8-2-2 Error Description.....	8-15

Section 9 AI Predictive Maintenance Library

9-1 Overview of AI Predictive Maintenance Library	9-2
9-2 Features of AI Predictive Maintenance Library	9-3

Appendices

A-1 Specifications	A-2
A-1-1 Specifications Unique to the AI Controllers.....	A-2
A-1-2 Common Specifications with Standard Models.....	A-5
A-2 List of System-defined Variables	A-6
A-2-1 Common Variables.....	A-6
A-2-2 Time Series Database Function.....	A-8
A-2-3 Feature Value/Machine Learning Function.....	A-10
A-2-4 WebAPI Function.....	A-13
A-3 Specifications for Individual System-defined Variables	A-14
A-3-1 System-defined Variables for the Overall AI Controller (No Category).....	A-14
A-3-2 AI Function Modules, Category Name: <code>_AIC</code>	A-16
A-3-3 AI Function Modules, Category Name: <code>_TSDB</code>	A-17
A-3-4 AI Function Modules, Category Name: <code>_FE</code>	A-23
A-3-5 AI Function Modules, Category Name: <code>_MLE</code>	A-24
A-3-6 AI Function Modules, Category Name: <code>_WAC</code>	A-26
A-4 Processing in the Data Collection, Data Analysis, and Data Utilization Phases	A-28
A-4-1 Data Collection Phase.....	A-28
A-4-2 Data Analysis Phase.....	A-29
A-4-3 Data Utilization Phase.....	A-29
A-5 CSV File Format	A-32
A-5-1 Variable Data File (RAW-***.csv).....	A-32
A-5-2 Analysis Data File (ANL-***.csv).....	A-33
A-5-3 Feature Value File (FTR-***.csv).....	A-34
A-5-4 Equipment Event Monitoring Result File (AIS-***.csv).....	A-35
A-6 Version Information	A-38
A-6-1 Version Information for NX-series AI Controllers.....	A-38
A-6-2 Version Information for NY-series AI Controllers.....	A-38
A-6-3 Specifications When Not Using the Sysmac Studio Version That Corresponds to the Unit Version of the AI Controller.....	A-38

Index

Terms and Conditions Agreement

Warranty, Limitations of Liability

Warranties

● Exclusive Warranty

Omron's exclusive warranty is that the Products will be free from defects in materials and workmanship for a period of twelve months from the date of sale by Omron (or such other period expressed in writing by Omron). Omron disclaims all other warranties, express or implied.

● Limitations

OMRON MAKES NO WARRANTY OR REPRESENTATION, EXPRESS OR IMPLIED, ABOUT NON-INFRINGEMENT, MERCHANTABILITY OR FITNESS FOR A PARTICULAR PURPOSE OF THE PRODUCTS. BUYER ACKNOWLEDGES THAT IT ALONE HAS DETERMINED THAT THE PRODUCTS WILL SUITABLY MEET THE REQUIREMENTS OF THEIR INTENDED USE.

Omron further disclaims all warranties and responsibility of any type for claims or expenses based on infringement by the Products or otherwise of any intellectual property right.

● Buyer Remedy

Omron's sole obligation hereunder shall be, at Omron's election, to (i) replace (in the form originally shipped with Buyer responsible for labor charges for removal or replacement thereof) the non-complying Product, (ii) repair the non-complying Product, or (iii) repay or credit Buyer an amount equal to the purchase price of the non-complying Product; provided that in no event shall Omron be responsible for warranty, repair, indemnity or any other claims or expenses regarding the Products unless Omron's analysis confirms that the Products were properly handled, stored, installed and maintained and not subject to contamination, abuse, misuse or inappropriate modification. Return of any Products by Buyer must be approved in writing by Omron before shipment. Omron Companies shall not be liable for the suitability or unsuitability or the results from the use of Products in combination with any electrical or electronic components, circuits, system assemblies or any other materials or substances or environments. Any advice, recommendations or information given orally or in writing, are not to be construed as an amendment or addition to the above warranty.

See <http://www.omron.com/global/> or contact your Omron representative for published information.

Limitation on Liability; Etc

OMRON COMPANIES SHALL NOT BE LIABLE FOR SPECIAL, INDIRECT, INCIDENTAL, OR CONSEQUENTIAL DAMAGES, LOSS OF PROFITS OR PRODUCTION OR COMMERCIAL LOSS IN ANY

WAY CONNECTED WITH THE PRODUCTS, WHETHER SUCH CLAIM IS BASED IN CONTRACT, WARRANTY, NEGLIGENCE OR STRICT LIABILITY.

Further, in no event shall liability of Omron Companies exceed the individual price of the Product on which liability is asserted.

Application Considerations

Suitability of Use

Omron Companies shall not be responsible for conformity with any standards, codes or regulations which apply to the combination of the Product in the Buyer's application or use of the Product. At Buyer's request, Omron will provide applicable third party certification documents identifying ratings and limitations of use which apply to the Product. This information by itself is not sufficient for a complete determination of the suitability of the Product in combination with the end product, machine, system, or other application or use. Buyer shall be solely responsible for determining appropriateness of the particular Product with respect to Buyer's application, product or system. Buyer shall take application responsibility in all cases.

NEVER USE THE PRODUCT FOR AN APPLICATION INVOLVING SERIOUS RISK TO LIFE OR PROPERTY OR IN LARGE QUANTITIES WITHOUT ENSURING THAT THE SYSTEM AS A WHOLE HAS BEEN DESIGNED TO ADDRESS THE RISKS, AND THAT THE OMRON PRODUCT(S) IS PROPERLY RATED AND INSTALLED FOR THE INTENDED USE WITHIN THE OVERALL EQUIPMENT OR SYSTEM.

Programmable Products

Omron Companies shall not be responsible for the user's programming of a programmable Product, or any consequence thereof.

Disclaimers

Performance Data

Data presented in Omron Company websites, catalogs and other materials is provided as a guide for the user in determining suitability and does not constitute a warranty. It may represent the result of Omron's test conditions, and the user must correlate it to actual application requirements. Actual performance is subject to the Omron's Warranty and Limitations of Liability.

Change in Specifications

Product specifications and accessories may be changed at any time based on improvements and other reasons. It is our practice to change part numbers when published ratings or features are changed, or when significant construction changes are made. However, some specifications of the Product may

be changed without any notice. When in doubt, special part numbers may be assigned to fix or establish key specifications for your application. Please consult with your Omron's representative at any time to confirm actual specifications of purchased Product.

Errors and Omissions

Information presented by Omron Companies has been checked and is believed to be accurate; however, no responsibility is assumed for clerical, typographical or proofreading errors or omissions.

Safety Precautions

Definition of Precautionary Information

The following notation is used in this manual to provide precautions required to ensure safe usage of the AI Controller.

The safety precautions that are provided are extremely important to safety. Always read and heed the information provided in all safety precautions.

The following notation is used.



WARNING

Indicates a potentially hazardous situation which, if not avoided, could result in death or serious injury. Additionally, there may be severe property damage.

Symbols



The circle and slash symbol indicates operations that you must not do. The specific operation is shown in the circle and explained in text. This example indicates prohibiting disassembly.



The triangle symbol indicates precautions (including warnings). The specific operation is shown in the triangle and explained in text. This example indicates a precaution against electric shock.



The triangle symbol indicates precautions (including warnings). The specific operation is shown in the triangle and explained in text. This example indicates a general precaution.



The filled circle symbol indicates operations that you must do. The specific operation is shown in the circle and explained in text. This example shows a general precaution for something that you must do.

WARNING

WARNING

Check the created parameters for proper execution before you use them for actual operation.



Before you set the parameters, make sure to confirm that no adverse effects will be caused by deviations in the timing of I/O. If you enable multiple data collections and monitoring settings, the task execution time may exceed the task period, I/O may not be refreshed with external devices, input signals may not be read, and output timing may change.



Before you restore backup data, make sure to confirm safety.



Refer to the following manuals for other safety precautions.

- *NX-series CPU Unit Hardware User's Manual (Cat. No. W535)*

- *NY-series Industrial Box PC Hardware User's Manual (Cat. No. W556)*
- *NY-series Industrial Panel PC Hardware User's Manual (Cat. No. W557)*

Precautions for Safe Use

- To ensure that equipment events are detected correctly, run the system to perform system evaluation. Depending on the AI Controller settings, equipment events may not be detected as you expected.
- Check the created parameters for proper execution and then use them for actual operation.

For any other precautions for safe use, refer to the following manuals.

- *NX-series CPU Unit Hardware User's Manual (Cat. No. W535)*
- *NY-series Industrial Box PC Hardware User's Manual (Cat. No. W556)*
- *NY-series Industrial Panel PC Hardware User's Manual (Cat. No. W557)*

Precautions for Correct Use

- Do not remove the SD Memory Card (for NX-series) or the SSD (for NY-series) from Drive Bay A while you are using the Time Series Database Function. Doing so will prevent these devices from saving TimeSeries data normally.
- Before you perform error determination, make sure that both the Feature Extraction Function and the Machine Learning Function are running.
- Before the power is interrupted, make sure to change the TSDB service status to *Shutdown*. If the power is interrupted without stopping the time series database, it could cause your valuable equipment data to be lost and cause the time series database to generate an error at the next power-on. If an error occurs with the time series database, perform necessary actions as specified in the troubleshooting procedures.
- To prevent a loss of data from the unexpected power interruption or momentary power interruption, take appropriate measures for the interruption with the uninterruptible power supply (UPS).
- Data is recorded in a ring buffer of the TimeSeries. Data in the TimeSeries may be overwritten according to the sampling period and the export period. The storage usage volume of the TimeSeries can be checked from the AI Operator. Make sure to adjust the export period when you use the Time Series Database Function.
- When the *TimeSeries Record Addition Failed* event occurs, replace the TimeSeries storage.
- If you insert a new storage into a wrong drive bay when you replace the storage, the AI Controller may not start up. Make sure to insert an expansion storage into Drive Bay A.
- Do not replace the main storage inserted into the AI Controller to another main storage of a different model. If you do so, it could prevent the AI Controller from starting up.
- If you use an OMRON SD Memory Card, the life expiration of the SD Memory Card can be detected in the following methods.
When the life expiration is detected, replace the SD Memory Card.
 - a) *_Card1Deteriorated* (SD Memory Card Life Warning Flag) system-defined variable
 - b) *SD Memory Card Life Exceeded* event

For any other precautions for correct use, refer to the following manuals.

- *NX-series CPU Unit Hardware User's Manual (Cat. No. W535)*
- *NY-series Industrial Box PC Hardware User's Manual (Cat. No. W556)*
- *NY-series Industrial Panel PC Hardware User's Manual (Cat. No. W557)*

Regulations and Standards

For details on using this product overseas, conformance to EU Directives, KC Certification, and the shipbuilding standards, refer to the following manuals.

- *NX-series CPU Unit Hardware User's Manual (Cat. No. W535)*
- *NY-series Industrial Box PC Hardware User's Manual (Cat. No. W556)*
- *NY-series Industrial Panel PC Hardware User's Manual (Cat. No. W557)*

Software Licenses and Copyrights

This product incorporates certain third party software. The license and copyright information associated with this software is available at http://www.fa.omron.co.jp/nj_info_e/.

OpenSSL

This product includes software developed by the OpenSSL Project for use in the OpenSSL Toolkit (<http://www.openssl.org/>).

Copyright (C) 1995-1998 Eric Young (eay@cryptsoft.com) All rights reserved.

This product includes cryptographic software written by Eric Young (eay@cryptsoft.com)

This Windows version of this product includes software written by Tim Hudson (tjh@cryptsoft.com)

Versions

Hardware revisions and unit versions are used to manage the hardware and software in NX/NY-series Units and EtherCAT slaves. The hardware revision or unit version is updated each time there is a change in hardware or software specifications. Even when two Units or EtherCAT slaves have the same model number, they will have functional or performance differences if they have different hardware revisions or unit versions.

Checking Versions

You can check versions on the ID information indications or with the Sysmac Studio.

Checking Unit Versions on ID Information Indications

The unit version is given on the ID information indication on the side of the product.

● Checking the Unit Version of an NX-series CPU Unit

The ID information on an NX-series NX701-Z□□□ CPU Unit is shown below.

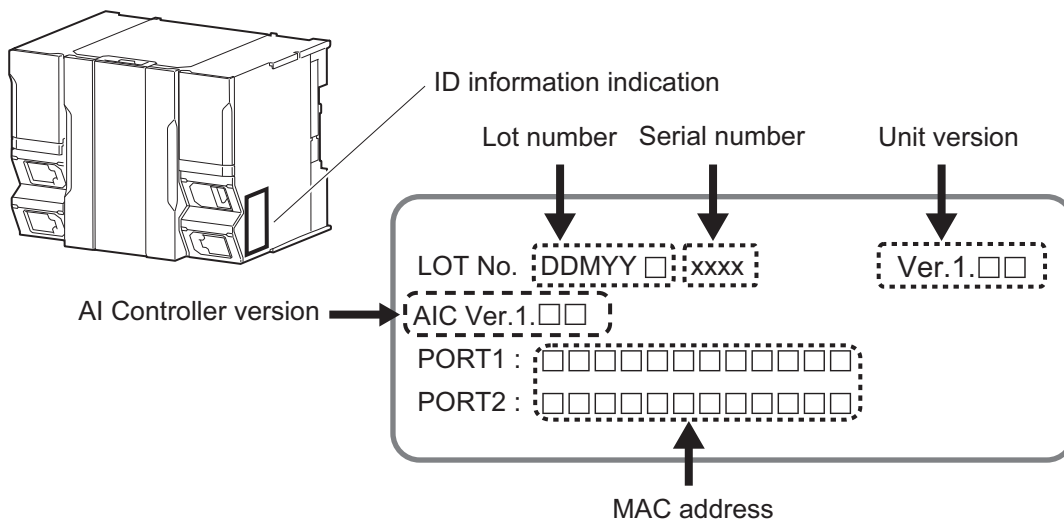

● Checking the Unit Version of an NY-series Controller

The ID information on an NY-series NY5□2-Z□□□ Controller is shown below.

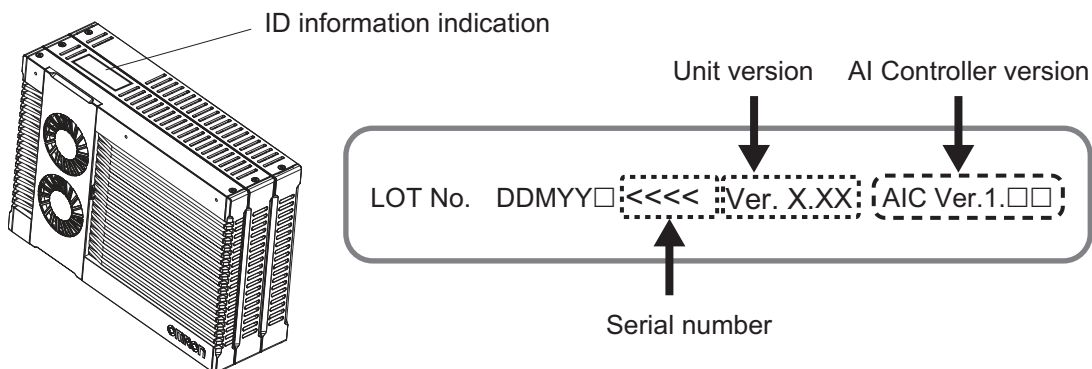

Checking Unit Versions with the Sysmac Studio

You can use the Sysmac Studio to check unit versions. The procedure is different for Units and for EtherCAT slaves.

● Checking the Unit Version of an NX-series CPU Unit

You can use the **Production Information** while the Sysmac Studio is online to check the unit version of a Unit. You can do this for the following Unit.

Model	Unit for which version can be checked
NX701-□□□□	CPU Unit

- 1 Right-click **CPU Rack** under **Configurations and Setup - CPU/Expansion Racks** in the Multi-view Explorer and select **Display Production Information**.
The **Production Information** Dialog Box is displayed.

● Checking the Unit Version of an NY-series Controller

You can use the **Production Information** while the Sysmac Studio is online to check the unit version of a Unit. You can only do this for the Controller.

- 1 Right-click **CPU Rack** under **Configurations and Setup - CPU/Expansion Racks** in the Multi-view Explorer and select **Display Production Information**.
The **Production Information** Dialog Box is displayed.

● Changing Information Displayed in Production Information Dialog Box

- 1 Click the **Show Outline** or **Show Detail** Button at the lower right of the **Production Information** Dialog Box.
The view will change between the **Production Information** details and outline.

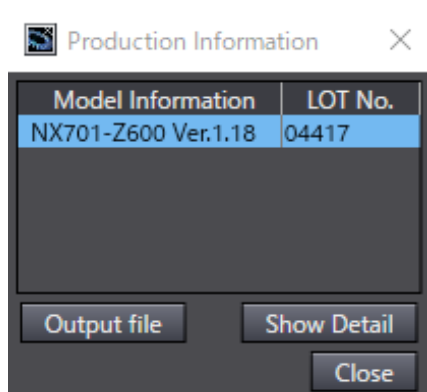

Outline View

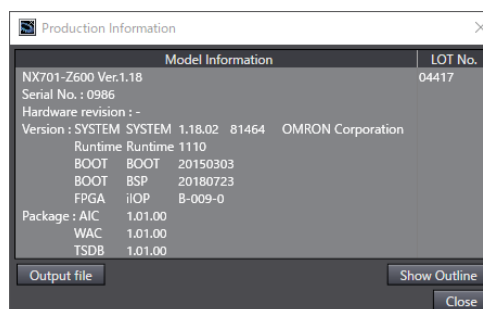

Detail View

The information displayed is different for the Outline View and the Detail View. The Detail View displays both the unit version and the AI Controller version. The Outline View displays only the unit versions.

Note The hardware revision is separated by “/” and is displayed on the right of the hardware version. The hardware revision is not displayed for the Unit that the hardware revision is in blank.

Related Manuals

The followings are the manuals related to this manual. Use these manuals for reference.

Manual name	Cat. No.	Model numbers	Application	Description
NX-series CPU Unit Hardware User's Manual	W535	NX701-□□□□	Learning the basic specifications of the NX701 CPU Units, including introductory information, designing, installation, and maintenance. Mainly hardware information is provided.	An introduction to the entire NX701 system is provided along with the following information on the CPU Unit. <ul style="list-style-type: none"> • Features and system configuration • Introduction • Part names and functions • General specifications • Installation and wiring • Maintenance and inspection
NJ/NX-series CPU Unit Software User's Manual	W501	NX701-□□□□ NX102-□□□□ NX1P2-□□□□ NJ501-□□□□ NJ301-□□□□ NJ101-□□□□	Learning how to program and set up an NJ/NX-series CPU Unit. Mainly software information is provided.	The following information is provided on a Controller built with an NJ/NX-series CPU Unit. <ul style="list-style-type: none"> • CPU Unit operation • CPU Unit features • Initial settings • Programming based on IEC 61131-3 language specifications
NJ/NX-series Instructions Reference Manual	W502	NX701-□□□□ NX102-□□□□ NX1P2-□□□□ NJ501-□□□□ NJ301-□□□□ NJ101-□□□□	Learning detailed specifications on the basic instructions of an NJ/NX-series CPU Unit.	The instructions in the instruction set (IEC 61131-3 specifications) are described.
NJ/NX-series CPU Unit Motion Control User's Manual	W507	NX701-□□□□ NX102-□□□□ NX1P2-□□□□ NJ501-□□□□ NJ301-□□□□ NJ101-□□□□	Learning about motion control settings and programming concepts.	The settings and operation of the CPU Unit and programming concepts for motion control are described.
NJ/NX-series Motion Control Instructions Reference Manual	W508	NX701-□□□□ NX102-□□□□ NX1P2-□□□□ NJ501-□□□□ NJ301-□□□□ NJ101-□□□□	Learning about the specifications of the motion control instructions.	The motion control instructions are described.
NJ/NX-series CPU Unit Built-in EtherCAT® Port User's Manual	W505	NX701-□□□□ NX102-□□□□ NX1P2-□□□□ NJ501-□□□□ NJ301-□□□□ NJ101-□□□□	Using the built-in EtherCAT port on an NJ/NX-series CPU Unit.	Information on the built-in EtherCAT port is provided. This manual provides an introduction and provides information on the configuration, features, and setup.
NJ/NX-series CPU Unit Built-in EtherNet/IP™ Port User's Manual	W506	NX701-□□□□ NX102-□□□□ NX1P2-□□□□ NJ501-□□□□ NJ301-□□□□ NJ101-□□□□	Using the built-in EtherNet/IP port on an NJ/NX-series CPU Unit.	Information on the built-in EtherNet/IP port is provided. Information is provided on the basic setup, tag data links, and other features.
NX-series CPU Unit FINS Function User's Manual	W596	NX701-□□□20 NX102-□□□□	Using the FINS function of an NX-series CPU Unit.	Describes the FINS function of an NX-series CPU Unit.

Manual name	Cat. No.	Model numbers	Application	Description
NX/NY-series Artificial Intelligence Machine Automation Controller User's Manual	W594	NX701-Z□□□ NY532-Z□□□ NY512-Z□□□	Learning about the NX/NY-series Artificial Intelligence Machine Automation Controller.	Describes the NX/NY-series Artificial Intelligence Machine Automation Controller overview, AI function specifications, system start-up, maintenance, and error details.
AI Controller Standard Software Operation Manual	W611	SYSMAC-AIGSTE□ □L	Learning an introduction of the AI Controller standard software and how to use it.	An introduction of the AI Controller standard software (AI Operator, AI Viewer), installation procedures, basic operations, connection operations, and operating procedures for main functions are described.
Sysmac Library AI Predictive Maintenance Library User's Manual	W610	SYSMAC-ZPA□□ □000W	Learning about AI predictive maintenance library and FB specifications.	Information necessary to use AI predictive maintenance library is provided.
NJ/NX-series Troubleshooting Manual	W503	NX701-□□□□ NX102-□□□□ NX1P2-□□□□ NJ501-□□□□ NJ301-□□□□ NJ101-□□□□	Learning about the errors that may be detected in an NJ/NX-series Controller.	Concepts on managing errors that may be detected in an NJ/NX-series Controller and information on individual errors are described.
Sysmac Studio Version 1 Operation Manual	W504	SYSMAC -SE2□□□	Learning about the operating procedures and functions of the Sysmac Studio.	Describes the operating procedures of the Sysmac Studio.
NY-series IPC Machine Controller Industrial Panel PC Hardware User's Manual	W557	NY532-□□□□	Learning the basic specifications of the NY-series Industrial Panel PCs, including introductory information, designing, installation, and maintenance. Mainly hardware information is provided.	An introduction to the entire NY-series system is provided along with the following information on the Industrial Panel PC. <ul style="list-style-type: none"> • Features and system configuration • Introduction • Part names and functions • General specifications • Installation and wiring • Maintenance and inspection
NY-series IPC Machine Controller Industrial Box PC Hardware User's Manual	W556	NY512-□□□□	Learning the basic specifications of the NY-series Industrial Box PCs, including introductory information, designing, installation, and maintenance. Mainly hardware information is provided.	An introduction to the entire NY-series system is provided along with the following information on the Industrial Box PC. <ul style="list-style-type: none"> • Features and system configuration • Introduction • Part names and functions • General specifications • Installation and wiring • Maintenance and inspection
NY-series IPC Machine Controller Industrial Panel PC / Industrial Box PC Setup User's Manual	W568	NY532-□□□□ NY512-□□□□	Learning about initial setting of the NY-series Industrial PCs and preparations to use Controllers.	The following information is provided on an introduction to the entire NY-series system. <ul style="list-style-type: none"> • Two OS systems • Initial settings • Industrial PC Support Utility • NYCompolet • Industrial PC API • Backup and recovery

Manual name	Cat. No.	Model numbers	Application	Description
NY-series IPC Machine Controller Industrial Panel PC / Industrial Box PC Software User's Manual	W558	NY532-□□□□ NY512-□□□□	Learning how to program and set up the Controller functions of an NY-series Industrial PC.	The following information is provided on the NY-series Controller functions. <ul style="list-style-type: none"> • Controller operation • Controller features • Controller settings • Programming based on IEC 61131-3 language specifications
NY-series Instructions Reference Manual	W560	NY532-□□□□ NY512-□□□□	Learning detailed specifications on the basic instructions of an NY-series Industrial PC.	The instructions in the instruction set (IEC 61131-3 specifications) are described.
NY-series IPC Machine Controller Industrial Panel PC / Industrial Box PC Motion Control User's Manual	W559	NY532-□□□□ NY512-□□□□	Learning about motion control settings and programming concepts of an NY-series Industrial PC.	The settings and operation of the Controller and programming concepts for motion control are described.
NY-series Motion Control Instructions Reference Manual	W561	NY532-□□□□ NY512-□□□□	Learning about the specifications of the motion control instructions of an NY-series Industrial PC.	The motion control instructions are described.
NY-series IPC Machine Controller Industrial Panel PC / Industrial Box PC Built-in EtherCAT® Port User's Manual	W562	NY532-□□□□ NY512-□□□□	Using the built-in EtherCAT port in an NY-series Industrial PC.	Information on the built-in EtherCAT port is provided. This manual provides an introduction and provides information on the configuration, features, and setup.
NY-series IPC Machine Controller Industrial Panel PC / Industrial Box PC Built-in EtherNet/IP™ Port User's Manual	W563	NY532-□□□□ NY512-□□□□	Using the built-in EtherNet/IP port in an NY-series Industrial PC.	Information on the built-in EtherNet/IP port is provided. Information is provided on the basic setup, tag data links, and other features.
NY-series Troubleshooting Manual	W564	NY532-□□□□ NY512-□□□□	Learning about the errors that may be detected in an NY-series Industrial PC.	Concepts on managing errors that may be detected in an NY-series Controller and information on individual errors are described.

Terminology

Term	Description
AIC	It is a package name indicating the AI Controller.
AI Operator	It is a tool to configure the AI function settings of the AI Controller as well as to monitor the status.
AI machine learning model	It is the data to monitor existence of equipment events by the AI Controller.
AI Viewer	It is a tool to visualize feature values and results of equipment events that are output by the Feature Value/Machine Learning Function. The AI Operator reads out data transferred from the AI Controller and displays it on a computer for the users to view.
AI Predictive Maintenance Library	It is one of the function components of the Sysmac Library in order to use the AI functions of the AI Controller.
Isolation Forest	It is an algorithm used for quantifying the degree of deviation from the normal range. For the AI Controllers, it is used for calculating equipment event monitoring scores.
TimeSeries	It is a unit of databases that are used in the Time Series Database Function. It is the database used for storing values of the variables in chronological order before generating an CSV file.
TSDB	It is a package name meaning TimeSeries DataBase.
WAC	It is a package name meaning WebAPI Connection.
WebAPI Connection Function	It is a function designed to transfer files from the AI Controller to the web server periodically.
machine learning output frame variables	It is a variable that is used to link an equipment event monitoring result with a frame. When an equipment event is output, a value of the corresponding frame variable is also output to this variable.
server certificate	It is an X.509 electronic certificate that certifies a web server. A web server generates and manages this certificate along with the secret key of the certificate.
subframe	It is a more detailed time range that is targeted for calculation within a frame.
Time Series Database Function	It is a function designed to collect variables and calculation result data of the Feature Value/Machine Learning Function in chronological order.
equipment event	It refers to a certain event that occurs on the equipment. It includes equipment events that will lead to quality problems and productivity problems (e.g. minor stops).
equipment event monitoring result	It is the judgment result indicating if an equipment event is present. It consists of the level (Normal, Alarm Level 1, Alarm Level 2) and the equipment event monitoring score.
Equipment event monitoring result file	It is a file containing the equipment event monitoring results that were calculated by the Feature Value/Machine Learning Function. The file name is AIS-****.csv (**** is time data).
equipment event monitoring score	It quantifies the degree of the existence of an equipment event. The larger value indicates that an equipment event is present.
feature extraction output frame variables	It is a variable that is used to link a feature value with a frame. When a feature value is output, a value of the corresponding frame variable is also output to this variable.
feature value	It is the data indicating the feature of variable data.
feature value calculation method	It is a conversion method for obtaining a feature value from variable data. The examples of methods include averaging and standard deviation.
Feature Value/Machine Learning Function	It is a function that extracts features and patterns from the running equipment and determines whether equipment events occur based on the extracted results and the AI machine learning model.

Term	Description
Feature value file	It is a file containing feature values that are calculated by the Feature Value/Machine Learning Function. The file name is FTR-****.csv (**** is time data).
frame	It is a range in which feature values are calculated by the Feature Value/Machine Learning Function.
Analysis data file	It is a file containing data used for generating an AI machine learning model. The file name is ANL-****.csv (**** is time data).
Variable data file	It is a file containing values of the variables. The file name is RAW-****.csv (**** is time data).
root certificate	It is the certificate installed in the client and used for checking if the server certificate retrieved from a web server is trusted. Only the server certificates that are trusted by the root certificate are considered as trusted certificates.

Revision History

A manual revision code appears as a suffix to the catalog number on the front and back covers of the manual.

Cat. No. W594-E1-02

↑ Revision code

Revision code	Date	Revised content
01	October 2018	Original production
02	July 2019	Made changes accompanying release of unit version 1.21 of the NX-series CPU Units and NY-series Controllers.

1

Overview and Features

This section describes the overview and features of the AI Machine Automation Controller.

1-1	Overview	1-2
1-2	Features	1-3
1-3	System Configuration	1-5
1-4	Functional Configurations Related to the AI Controller	1-6
1-4-1	AI Controller Function	1-7
1-4-2	AI Controller Software	1-8
1-4-3	Types of Data	1-10
1-5	Overview of Operating Procedures	1-11
1-5-1	Data Collection/Data Analysis/Data Utilization	1-11
1-5-2	Relationship between AI Functions and Phases	1-11
1-5-3	Relationship between AI Controller Software and Phases	1-12
1-6	List of Models	1-13

1-1 Overview

The AI Machine Automation Controllers (Abbreviation: AI Controllers) refer to NX-series Machine Automation Controllers and Industrial PC Platform NY-series Controllers with AI functions.

The AI functions are designed to improve the equipment's utilization rate as they detect equipment events (events that occur in the equipment, e.g. errors that cause quality issues) including equipment errors and the end of service life, as well as behaviors that are the signs of such events. In addition, the AI Controller software (AI Operator and AI Viewer) allows you to monitor equipment events easily without the special knowledge of mathematics or statistics.

When you use the AI Controller in all three phases of data collection, analysis, and utilization, you can expect the equipment's utilization rate to rise. An engineer of OMRON supports your needs in all phases.

The NX-series Machine Automation Controllers and the Industrial PC Platform NY-series Controllers are the basis of the AI Controller and have the following features.

The NX-series Machine Automation Controllers and the Industrial PC Platform NY-series Controllers are the next-generation controllers that provide the functionality and high-speed performance that are required for machine control, as well as the safety, reliability, and serviceability that are required for industrial controllers.

They provide the functionality of previous OMRON PLCs and the functionality required for motion control. Synchronized control of I/O devices on high-speed EtherCAT can be applied to safety devices, vision systems, motion equipment, discrete I/O, and more.

OMRON offers the new Sysmac Series of control devices designed with unified communications specifications and user interface specifications. The NX-series Machine Automation Controllers and the Industrial PC Platform NY-series Controllers are part of the Sysmac Series. You can use them together with EtherCAT slaves, other Sysmac products, and the Sysmac Studio Automation Software to achieve optimum functionality and ease of operation.

With a system that is created from Sysmac products, you can connect components and operate the system through unified concepts and usability.

1-2 Features

The AI Controller has the following features.

Inherited NX-series and NY-series Controller Functions

The AI Controller has inherited the PLC function of the conventional NX-series or NY-series Controllers. In addition to the conventional PLC function, it also has the AI function that allows you to monitor equipment events. This allow you to control the Controller by PLC function and monitor the equipment events by the AI function.

Data Collection by the Time Series Database Function

The AI Controller has the Time Series Database Function designed for data collection in the storage*¹ mounted to the NX-series and NY-series Controllers. The data collection intervals are synchronized with the PLC function module's scheduling. Using the synchronized data allows you to use the data for improving and recording the equipment.

*1. An SD Memory Card is provided with the NX-series AI Controller.

Feature Value/Machine Learning Function

- The Feature Value/Machine Learning Function is loaded on the NX-series Controllers and the NY-series Controllers.
- By downloading the AI machine learning model to the Feature Value/Machine Learning Function loaded on the AI Controller, the AI Controller can monitor the equipment events. The AI machine learning model refers to data acquired through machine learning and statistics technologies.

Function to Upload Files to Web Server Securely

The NX-series and NY-series Controllers have a function that periodically upload files that are stored in them to a web server with the HTTPS protocol. This function is useful for transferring equipment status data including calculation results of the AI function to a Web server and for analyzing the data.

Sysmac Library - AI Predictive Maintenance Library

The AI Predictive Maintenance Library is one of the function components of the Sysmac Library software to use the AI functions of the AI Controller. The AI predictive maintenance library makes the programming for using AI functions easier.

Visualization by NA-series Programmable Terminals

With NA-series Programmable Terminals, you can monitor the results that the AI Controller determined on site. You can also monitor the operating status of the AI functions that operate in the AI Controller.

You can easily create the NA-series programmable terminal screen because the screen data for the AI Controllers is provided.

1-3 System Configuration

The system configuration of the AI Controller is described below.

The NX-series and NY-series Controllers have the three AI functions: "Time Series Database Function", "Feature Value/Machine Learning Function", and "WebAPI Connection Function". In addition, the two types of support software for the AI Controller, "AI Operator" and "AI Viewer", are available.

Install a web server if you want to transfer files of the results calculated by the AI Controller to a web server.

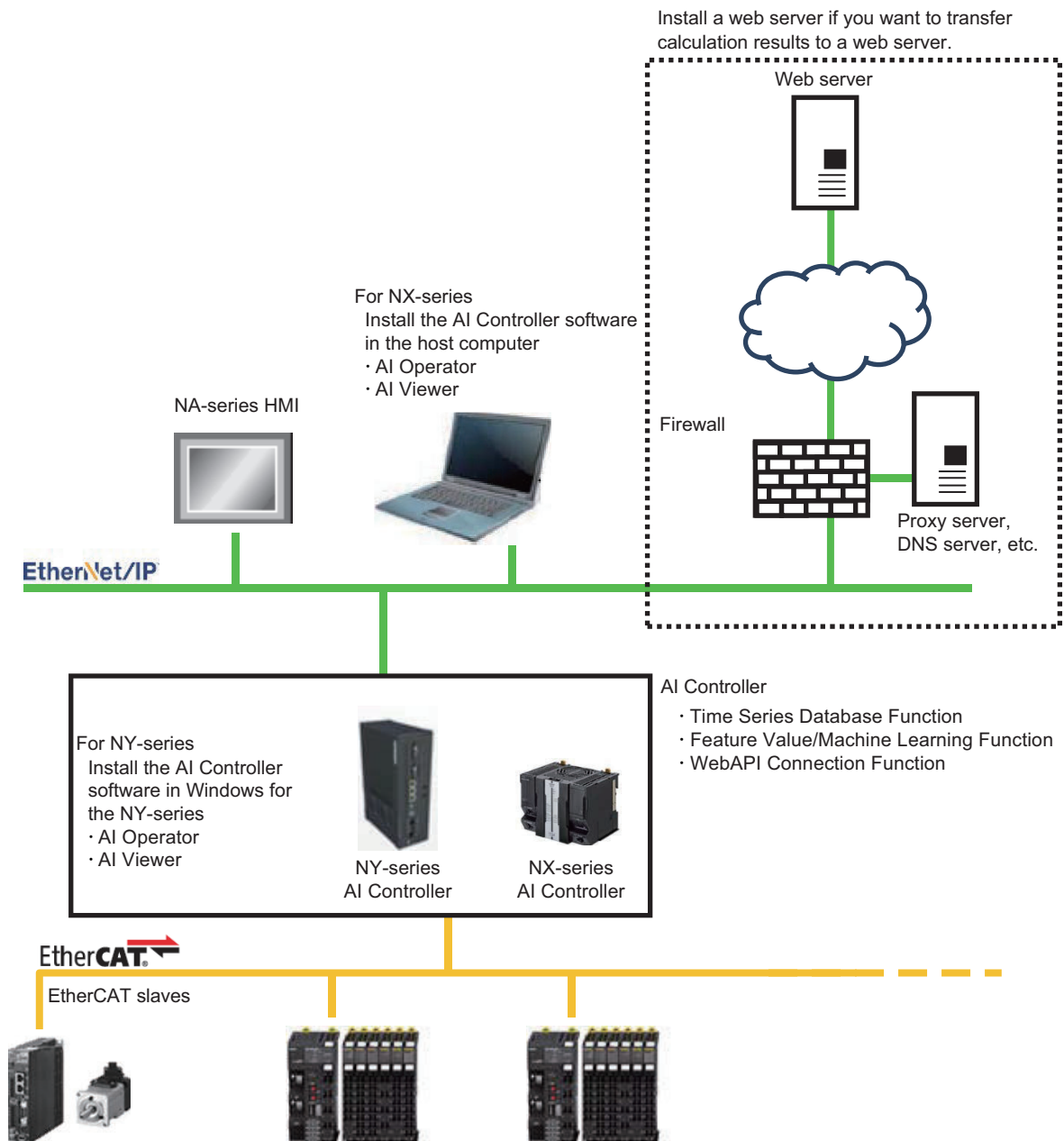

1-4 Functional Configurations Related to the AI Controller

This section describes the function blocks related to the AI Controller.

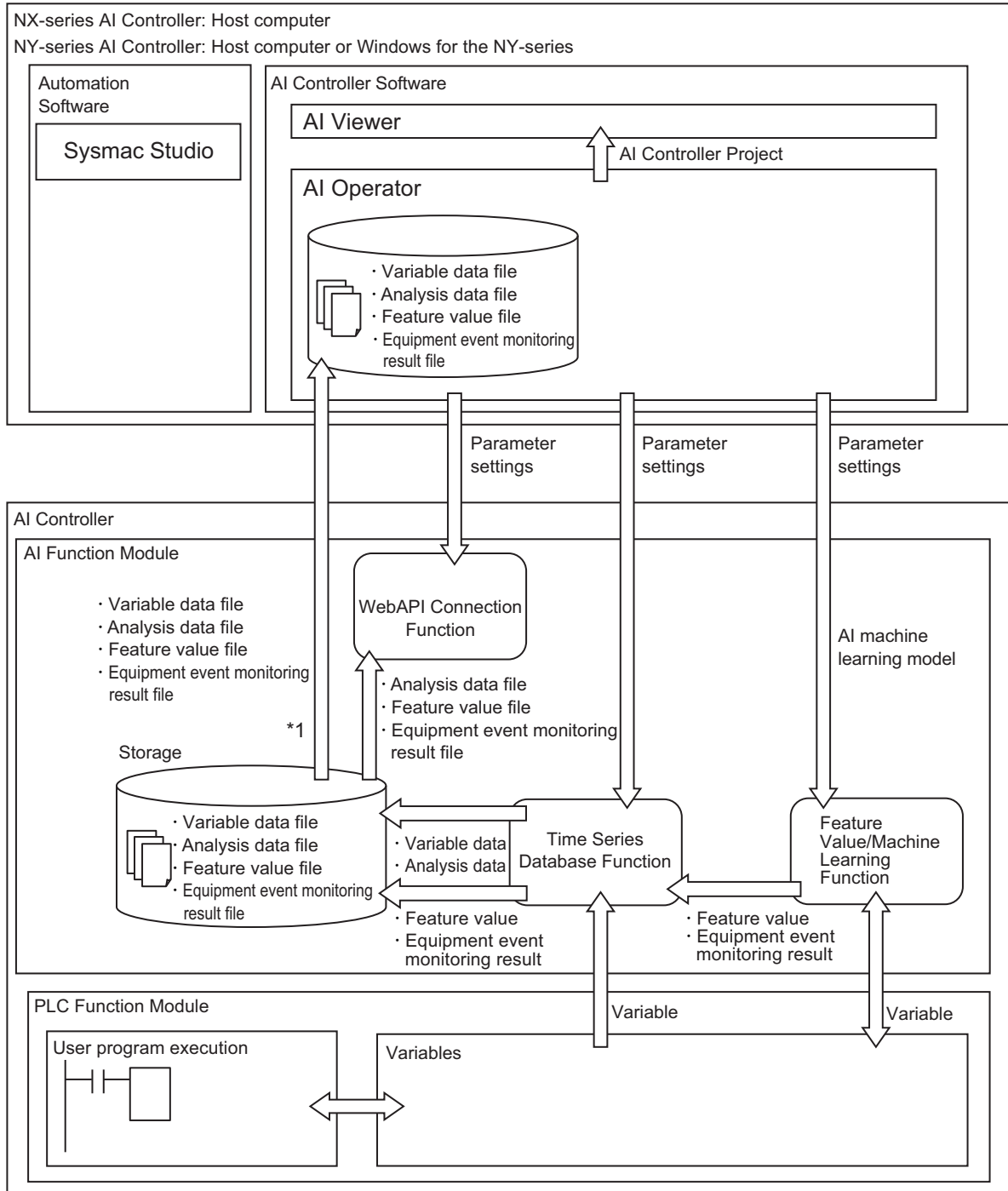

*1. The FTP protocol is used for transferring files from the AI Controller to the AI Operator. When you use AI Operator, you can use three FTP server connections on the AI Controller.

1-4-1 AI Controller Function

Time Series Database Function

The Time Series Database Function collects values of user-specified variables and calculation results of the Feature Value/Machine Learning Function into the storage for each sampling interval.

This function allows you to collect data such as variable values to the storage without program. The collected data can be checked on the AI Viewer. In addition, the data can be transferred to a web server by the WebAPI Connection Function.

Feature Value/Machine Learning Function

The Feature Value/Machine Learning Function determines whether equipment events occur from the collected data and AI machine learning model. It consists of the Feature Extraction Function and the Machine Learning Function. The Feature Extraction Function calculates feature values from data. The Machine Learning Function on the other hand determines whether equipment events occur from feature values and AI machine learning model.

WebAPI Connection Function

The WebAPI Connection Function transmits data (CSV files) that is collected by the Time Series Database Function in the AI Controller to a web server periodically. This function can be used to transfer data (CSV files) that are collected by the Time Series Database Function to a web server and to save and analyze data.

Considering that data will be transmitted via Internet, data is encrypted in the transmission path to the web server.

1-4-2 AI Controller Software

"AI Operator" and "AI Viewer" are the software exclusively designed for the AI Controller. The functions of each software are described below.

AI Operator

The AI Operator is a tool to configure AI function (Time Series Database Function, Feature Value/Machine Learning Function, WebAPI Connection Function) settings of the AI Controller as well as to monitor the status. It works on Windows.

The AI Operator also provides a function for transferring results of calculation performed by the Feature Value/Machine Learning Function from the AI Controller to a computer.

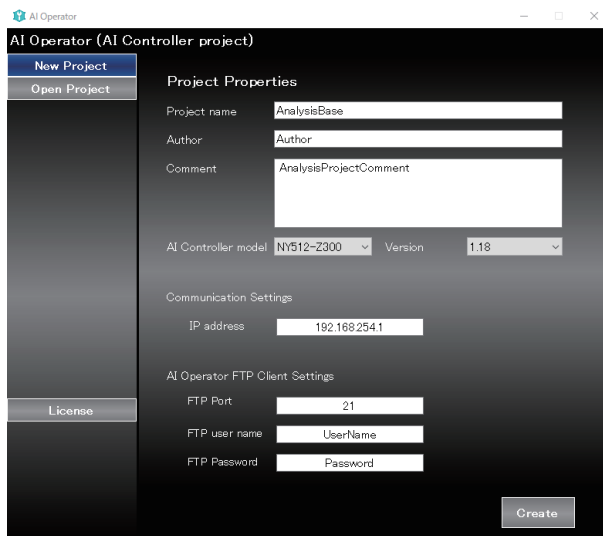

AI Viewer

The AI Viewer is a tool to visualize feature values and results of equipment events that are output by the Feature Value/Machine Learning Function. It works on Windows.

The AI Operator reads out data transferred from the AI Controller and displays it on a computer for the users to view.

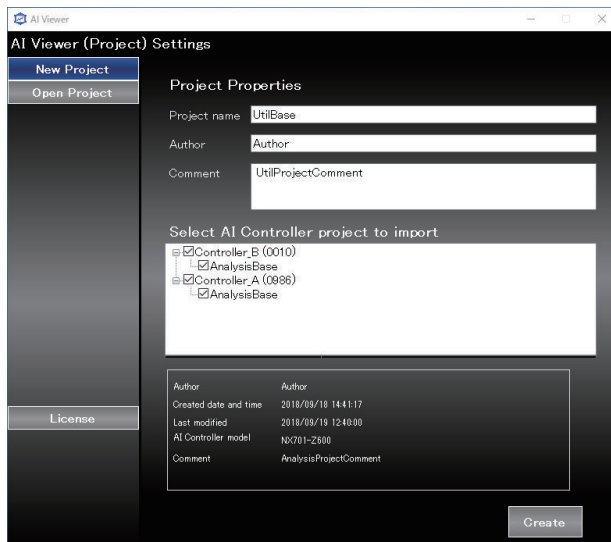

1-4-3 Types of Data

This section describes data that is exchanged between function blocks.

Data name	Description
Variable data	Variable data refers to the AI Controller variable values necessary to monitor equipment events.
Analysis data	Analysis data refers to variable data with the frame variables and sub-frame variables added. Refer to <i>Section 2 Time Series Database Function</i> on page 2-1 for details on frame variables and subframe variables.
Feature value	It is a numeric value indicating the feature of analysis data. The feature values are calculated by the Feature Value/Machine Learning Function.
Equipment event monitoring results	They are the monitoring results of equipment events. The results are calculated by the Feature Value/Machine Learning Function and collected in the storage by the Time Series Database Function.
AI machine learning model	It refers to data (calculation method of feature value, threshold values, etc.) necessary to monitor equipment events. An engineer of OMRON generates the model from analysis data. The data needs to be downloaded from the AI Operator to the AI Controller in advance. The AI Controller calculates results based on the data and monitors the equipment events.
AI Controller project	They are the AI Viewer setting file including equipment event names and feature values, which is generated by the AI Operator. The AI Viewer uses this file to display the equipment event monitoring results.

1-5 Overview of Operating Procedures

This section describes the operating procedure for the AI Controller. There are three phases in the operating procedure: *Data Collection*, *Data Analysis*, and *Data Utilization*. You can use the AI Controller by following the steps in order.

1-5-1 Data Collection/Data Analysis/Data Utilization

The operation details performed in each phase of data collection, data analysis, and data utilization are described below.

Phase	Description
Data Collection	Run the equipment and collect data on the equipment's operation status. You need to decide variables to collect and specify them to the AI Controller with the AI Operator. You will then run the equipment and collect analysis data. The analysis data are collected in the storage of the AI Controller.
Data Analysis	An AI machine learning model is generated from the analysis data that was collected in the Data Collection Phase. The AI machine learning model is downloaded to the AI Controller. The AI machine learning model is generated by an engineer of OMRON.
Data Utilization	The AI Controller determines whether an equipment event is present. An equipment event is determined from data that was collected while the AI machine learning model and the equipment were actually running. The determination results of equipment events are recorded in the storage and output to the AI Viewer. Make sure to check that equipment events can be detected in this phase. If the events can not be detected, perform the Data Collection Phase or Data Analysis Phase again.

1-5-2 Relationship between AI Functions and Phases

The AI functions used for each phase are described below.

Phase	AI functions		
	Time Series Database Function	Feature Value/Machine Learning Function	WebAPI Connection Function
Data Collection	Collects data during equipment operation and generates a file (CSV file) of the variable data and analysis data in the storage of the AI Controller.	This function is not used.	This function is not used.
Data Analysis	This function is not used.	This function is not used.	This function is not used.
Data Utilization	Collects feature values and determination results of equipment events calculated by the Feature Value/Machine Learning Function in the storage. Analysis data can also be collected.	Calculates the feature values from variable data and performs the determination of the equipment events from the calculated feature values and the AI machine learning model. The determined results can be checked on the AI Viewer.	Transfers data (CSV files) that are generated by the Time Series Database Function, to a web server periodically.

1-5-3 Relationship between AI Controller Software and Phases

The AI Controller software used for each phase are described below.

Phase	AI Controller Software	
	AI Operator	AI Viewer
Data Collection	Configure the Time Series Database Function.	This software is not used.
Data Analysis	Download the AI machine learning model to the AI Controller. The AI machine learning model is generated by an engineer of OMRON.	This software is not used.
Data Utilization	Check the operating status of the AI functions (Time Series Database Function, Feature Value/Machine Learning Function, WebAPI Connection Function).	Load the feature values and determination results of equipment events collected in the storage of the AI Controller on a computer to visualize them.

1-6 List of Models

The following table describes the AI Controller models and software that you use. Refer to *A-6-1 Version Information for NX-series AI Controllers* on page A-38 or *A-6-2 Version Information for NY-series AI Controllers* on page A-38 for information on the unit version of the AI Controller and each software version.

Series name	Model	Software that you use
NX-series AI Controller	NX701-Z600	<ul style="list-style-type: none"> • Sysmac Studio*¹ • AI Operator • AI Viewer
	NX701-Z700	
NY-series AI Controller	NY512-Z300	<ul style="list-style-type: none"> • Sysmac Studio*^{1,2} • AI Operator • AI Viewer
	NY512-Z400	
	NY512-Z500	
	NY532-Z300	<ul style="list-style-type: none"> • Industrial PC Support Utility*³ • Rescue Disk Creator*³
	NY532-Z400	
	NY532-Z500	

*1. Before you perform the AI Controller programming on the Sysmac Studio, the license registration is required. For details on the procedures of the license registration, refer to *Displaying and Registering Licenses* in the *Sysmac Studio Version1 Operation Manual (Cat. No. W504)*.

*2. Refer to the file below for the NY-series AI Controllers.
D:\OMRON-NY\Installers\AI_Controller_Standard_Software\README.txt

*3. It is pre-installed in the NY-series AI Controller. The latest version is available from the download page of the OMRON website (http://www.omron-cxone.com/ipc-platform/index_en.html).

2

Time Series Database Function

This section describes the Time Series Database Function that is included in the AI Controller.

2-1	Function Overview	2-2
2-2	Collected Data	2-4
2-2-1	Types of Collected Data	2-4
2-2-2	Collection Timing	2-4
2-3	TSDB Service Status.....	2-5
2-3-1	Status.....	2-5
2-3-2	Checking Method.....	2-5
2-3-3	Change Method	2-6
2-4	How to Start and Stop Sampling and Export.....	2-7
2-5	List of Settings	2-8
2-6	Statistical Information	2-9
2-7	Restrictions	2-10

2-1 Function Overview

The Time Series Database Function allows you to save user-specified variables and calculation results of the Feature Value/Machine Learning Function into the storage of the AI Controller. Collected data is first saved in a database called TimeSeries and then saved in the storage. High-speed data recording was made possible by installing a database functionality inside the AI Controller. The operation of saving data into TimeSeries is referred to as "sampling", and the operation of saving data from TimeSeries to the storage is referred to as "export".

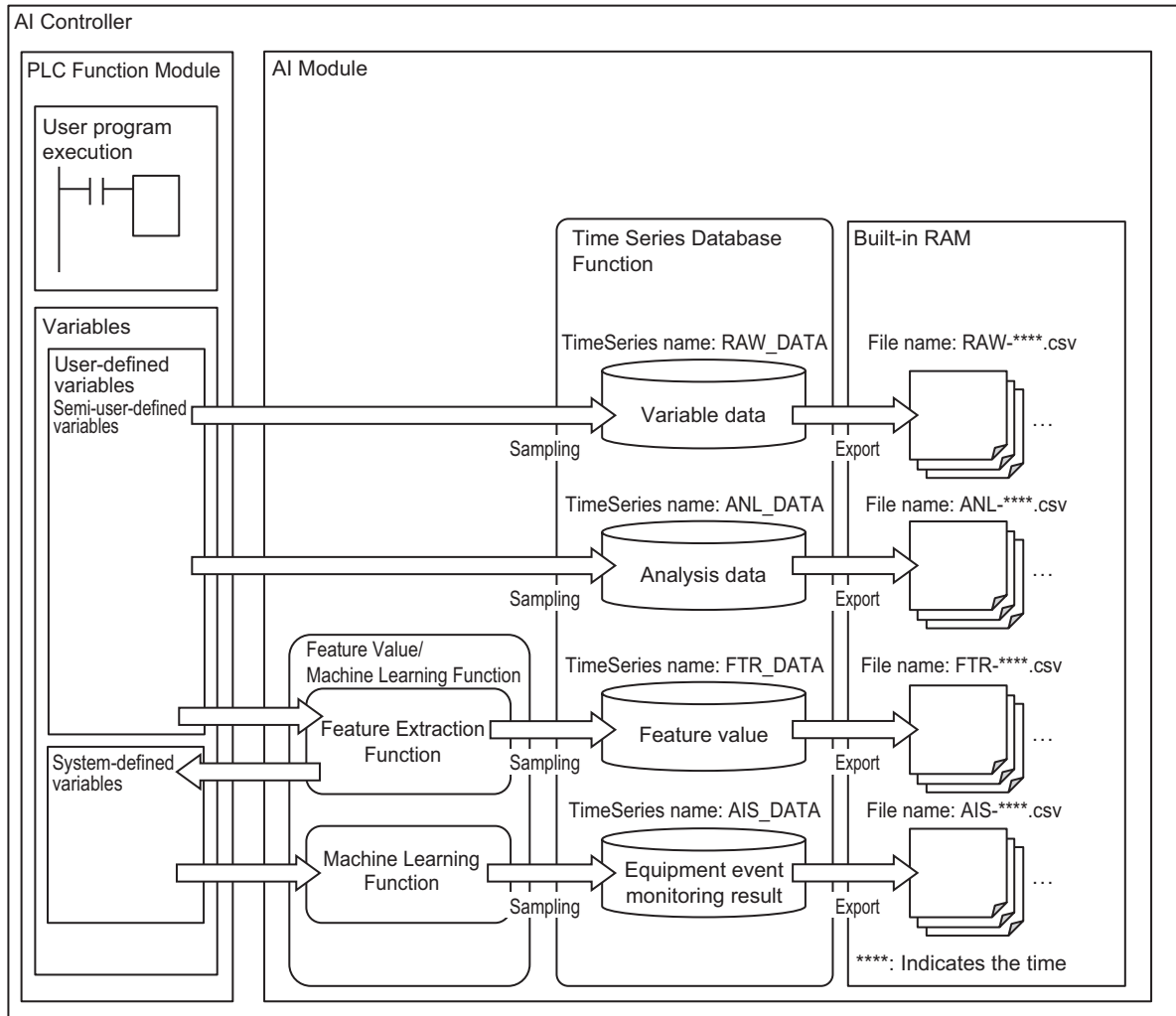

- TimeSeries and the storage type vary for the NX-series and the NY-series as described below. When you use the AI Controller, insert the SD Memory Card or the SSD into Drive Bay A.

Series name	Storage location of TimeSeries	Storage location of CSV file
NX-series	SD Memory Card	Built-in RAM
NY-series	SSD in drive bay A	Built-in RAM

- The general specifications are as follows:

TimeSeries	Item	Specifications
TimeSeries common	Method	Time-series database (It uses a circular queue where the oldest data is deleted if it reaches the maximum number of data.)
	Number of TimeSeries	4
	Sampling start/stop method	It can be executed in any of the following methods: <ul style="list-style-type: none"> AI Operator System-defined variables Instructions
	Export start/stop method	It can be executed in any of the following methods: <ul style="list-style-type: none"> AI Operator System-defined variables Instructions
	Number of used variables with a Retain attribute	2*1
Variable data (RAW_DATA)	Size of the TimeSeries	NX-series: 900 MB NY-series: 41 GB
	Number of variables [variables/record]*2	1024
	Category of variable	Global variable
	Variable type	The following variables can be specified: <ul style="list-style-type: none"> Basic data types Specifying a whole array or elements of an array Specifying a whole structure or union, or members of a structure or a union
Analysis data (ANL_DATA)	Size of the TimeSeries database	NX-series: 1 GB NY-series: 30 GB
	Number of variables [variables/record]*2	2048 (including variable data, frame variables, sub-frame variables, and label variables)
	Category of variable	Global variable
	Variable type	The following variables can be specified: <ul style="list-style-type: none"> Basic data types Specifying array elements: Specifying members of a structure or a union

- *1. The Time Series Database Function uses two variables with a Retain attribute in the system. The maximum number of available variables with a Retain attribute is 39,998.
- *2. A record refers to a set of data saved in the TimeSeries in a sampling task. It corresponds to a row in the exported CSV file.

2-2 Collected Data

2-2-1 Types of Collected Data

This section describes data that is collected in the storage by the Time Series Database Function. The collected data (CSV files) can be visualized and checked on the AI Viewer.

Name of the collected file	TimeSeries	Description	Phase in which collected data is used
RAW-****.csv ^{*1}	RAW_DATA	Variable data are collected. Variable data to collect can be configured on the AI Operator.	Data Collection
ANL-****.csv ^{*1}	ANL_DATA	Variable data, frame variables ^{*2} , and subframe variables ^{*2} are collected. This data is used in the Data Analysis Phase.	Data Analysis
FTR-****.csv ^{*1}	FTR_DATA	Feature values calculated by the Feature Extraction Function are collected.	Data Utilization
AIS-****.csv ^{*1}	AIS_DATA	Monitoring results of the equipment events calculated by the Machine Learning Function are collected.	Data Utilization

*1. **** indicates the time (in the format of YYYYMMddHHMMSSsss) when a file was created. For example, when a file was created on January 2, 2018, at 12:15 and 30 seconds 333 milliseconds, it shows 20180102121530333.

*2. Refer to *Section 3 Feature Value/Machine Learning Function* on page 3-1 for details on frame variables and subframe variables.

2-2-2 Collection Timing

Variable Data (RAW_DATA)/Analysis Data (ANL_DATA)

The TSDB service, which realizes the Time Series Database Function, collects values of all the specified variables by *system common processing 2* of the primary periodic task.

For details on the *system common processing 2*, refer to the *NJ/NX-series CPU Unit Software User's Manual (Cat. No. W501)*.

Feature Values (FTR_DATA)/Equipment Event Monitoring Results (AIS_DATA)

They are collected at the operation timing of the Feature Value/Machine Learning Function. This timing cannot be changed.

2-3 TSDB Service Status

TSDB service is a service that realizes the Time Series Database Function. TSDB is an abbreviation for Time Series Data Base.

2-3-1 Status

The TSDB service has the following status.

The status is changed regardless of the operating mode (PROGRAM or RUN mode) of the AI Controller.

Status	Description	Conditions for status transition
Idle	It indicates that the TSDB service is stopped except for the cases of errors.	<ul style="list-style-type: none"> Instructions or commands by the AI Operator*1 Downloading by the Sysmac Studio Clear all memory Restore execution of the Sysmac Studio Controller Backups
Running	The TSDB service is running. Sampling and export are ready to be executed. Refer to <i>2-4 How to Start and Stop Sampling and Export</i> on page 2-7 for details on the execution method.	<ul style="list-style-type: none"> When there is no error after powering on the AI Controller When there is no error after the controller reset for the AI Controller Instructions or commands by the AI Operator*1
Error	The service cannot be started due to errors (corruption of the setting file, etc.) of the TSDB service.	When there is an error in the TSDB service
Shutdown	The TSDB service has been shut down. The AI Controller power is ready to be turned off. Once the service has entered in this state, you can no longer set the TSDB service to running status again.	<ul style="list-style-type: none"> Instructions or commands by the AI Operator*1 Instruction by system variables*2 Shutdown of the NY-series AI Controller When a major fault level error occurs

*1. The instruction used here is the TimeSeries_ControlService instruction.

*2. The system-defined variable used here is `_TSDB_ShutdownCmd`. The shutdown processing is executed when this variable changes to TRUE.

2-3-2 Checking Method

You can check the TSDB service status from the `_TSDB_Status` system defined variable.

While the status transition is in progress, the members of the `_TSDB_Status` system defined variable changes to FALSE.

Status	Members of the <code>_TSDB_Status</code> system defined variable			
	<code>.Idle</code>	<code>.Run</code>	<code>.Error</code>	<code>.Shutdown</code>
Idle	TRUE	FALSE	FALSE	FALSE
Running	FALSE	TRUE	FALSE	FALSE
Error	FALSE	FALSE	TRUE	FALSE
Shutdown	FALSE	FALSE	FALSE	TRUE

2-3-3 Change Method

You can send a command to start, stop, or shutdown the service with an instruction or the AI Operator.



Precautions for Correct Use

- Before the power is interrupted, make sure to change the TSDB service status to *Shutdown*. If the power is interrupted without stopping the time series database, it could cause your valuable equipment data to be lost and cause the time series database to generate an error at the next power-on. If an error occurs with the time series database, perform necessary actions as specified in the troubleshooting procedures.
 - To prevent a loss of data from the unexpected power interruption or momentary power interruption, take appropriate measures for the interruption with the uninterruptible power supply (UPS).
-

● Instructions

The status can be changed with the `TimeSeries_ControlService` instruction. Refer to *TimeSeries_Control/Service* on page 5-2 for details on how to use the instruction.

● AI Operator

To modify the status, go to the **Monitor/Operation - TSDB Function** screen on the AI Operator, and click the **Start**, **Stop**, or **Shutdown** Button for the TSDB service.

2-4 How to Start and Stop Sampling and Export

The following describes the procedure to start and stop sampling and export.

Transfer type	TimeSeries	Start and stop method
Sampling	RAW_DATA	When you use a start or stop command in any of the following methods while the TSDB service is running, you can start or stop the sampling. <ul style="list-style-type: none"> • AI Operator • System-defined variables^{*1} • Instructions^{*2} Refer to <i>Section 5 Time Series Database Instructions</i> on page 5-1 for details on how to use the instructions.
	ANL_DATA	
	FTR_DATA	Sampling is executed while the TSDB service and the Feature Value/Machine Learning Function are running. The start or stop command by a user cannot be accepted.
	AIS_DATA	
Export	RAW_DATA	When you use a start or stop command in any of the following methods while the TSDB service is running, you can start or stop the export. <ul style="list-style-type: none"> • AI Operator • System-defined variables^{*3} • Instructions^{*4} Refer to <i>Section 5 Time Series Database Instructions</i> on page 5-1 for details on how to use the instructions.
	ANL_DATA	
	FTR_DATA	
	AIS_DATA	

- *1. The system-defined variables here refer to `_TSDB_SmplStartCmd` (Sampling Start Command) and `_TSDB_SmplStopCmd` (Sampling Stop Command). The start processing and stop processing are executed when these variables are loaded.
- *2. The instruction used here is the `TimeSeries_ControlSampling` instruction.
- *3. The system-defined variables here refer to `_TSDB_ExptStartCmd` (Export Start Command) and `_TSDB_ExptStopCmd` (Export Stop Command). The start processing and stop processing are executed when these variables are loaded.
- *4. The instruction used here is the `TimeSeries_ControlExport` instruction.

2-5 List of Settings

The settings for the Time Series Database Function are described below. These settings can be set from the AI Operator.

AI Operator screen	Setting	Description	Corresponding TimeSeries	Set value	Default
Equipment Event Settings	Linked Variables	Specify variable data to collect in analysis data (ANL-****.csv).	ANL_D ATA	---	None
	Frame Variable (ANY_INT)	Specify a frame variable to collect in analysis data (ANL-****.csv).		---	None
	Sub-frame Variable (BOOL)	Specify a subframe variable to collect in analysis data (ANL-****.csv).		---	None
	Label Variable (ANY_INT)	Specify a label variable to collect in analysis data (ANL-****.csv).		---	None
Extension Func. Variable Data Collection	Registered variable name	Specify variable data to collect in variable data (RAW-****.csv) as the extension function.	RAW_D ATA	---	None
Extension Func. Detailed Settings	Number of exported records	When the number of records accumulated in the TimeSeries reaches the number of export records specified here, export is executed.	RAW_D ATA	Always 10,000	---
			ANL_D ATA		---
			FTR_D ATA	10,000 to 1	10,000
			AIS_D ATA		10,000
	Export execution cycle	Even when the number of records accumulated in the TimeSeries does not reach the number of export records, export is executed after the export execution period specified here.	RAW_D ATA	Always 1s	---
			ANL_D ATA		---
			FTR_D ATA	100 to 1 s	10
			AIS_D ATA		10

2-6 Statistical Information

Statistical information of the Time Series Database Function can be verified on **Statistics - TSDB Function** screen on the AI Operator.

The AI Operator's statistical information display		Description
TimeSeries information	Storage usage (Byte)	It specifies the usage volume of the TimeSeries.
	Number of records stored	It specifies the number of records stored in TimeSeries.
	Time of the latest record	It specifies the time of the latest record stored in TimeSeries.
	Time of the oldest record	It specifies the time of the oldest record stored in TimeSeries.
Sampling processing	Number of executed samplings	It specifies the number of sampling processes executed for TimeSeries.
	Sampling execution failure count	It specifies the number of sampling failed for data in TimeSeries.
	Maximum sampling time [ms]	It specifies the maximum sampling time per record in TimeSeries.
	Average sampling time [ms]	It specifies the average sampling time per record in TimeSeries.
Internal buffer status	Maximum number of records accumulated in the internal buffer	This field is used by an engineer of OMRON.
	Number of records discarded by internal buffer	This field is used by an engineer of OMRON.
	Number of records currently accumulated in internal buffer	This field is used by an engineer of OMRON.
Export processing	Maximum export time [ms]	It specifies the maximum value of export time.
	Average export time [ms]	It specifies the average value of export time.
	Export execution count	It specifies the number of export executed.

2-7 Restrictions

The following restrictions apply to the Time Series Database Function.

- When the AI Controller power was turned off with the TSDB service status set to other than "Shutdown", the contents of the TimeSeries and CSV files cannot be guaranteed. Make sure to turn off or reset the AI Controller after you shut down the TSDB service.
 - Data is recorded in a ring buffer of the TimeSeries. Data in the TimeSeries may be overwritten according to the sampling period and the export period. The storage usage volume of the TimeSeries can be checked from the AI Operator. Make sure to adjust the export period when you use the Time Series Database Function.
 - In some cases, values of variables in all the periods are not retrieved in an CSV file. You can check the *index*^{*1} field of the CSV file to check if all the data has been retrieved. If all the data was not retrieved, perform the following:
 - a) Reduce the volume of variables (size and number of variables) to collect.
 - b) Increase the task period of the primary periodic task.
 - c) Decrease the export period.
 - d) Secure the execution time for the system services.
- *1. For details on the *index* in the CSV file, refer to *Appendices* on page A-1.
- Since the storage to output files is in the RAM area, files are deleted when you turn OFF the AI Controller power or reset the controller. Before you turn OFF the AI Controller or reset the controller, make sure to read out the data on the AI Operator or transfer the data with the WebAPI function.
 - If you are using an NX-series AI Controller, the 8 GB memory out of the 16 GB SD Memory Card is used for the AI functions. Therefore, the remaining 8 GB is available for the users. Refer to *A-1-1 Specifications Unique to the AI Controllers* on page A-2 for the specifications of an SD Memory Card.
 - The task processing period becomes longer when the TSDB function is activated. After you run the TSDB function, make sure to perform the system evaluation. Note that *Execution Time Estimation Mode* of the Simulator on the Sysmac Studio is not supported.

3

Feature Value/Machine Learning Function

This section describes the Feature Value/Machine Learning Function that is included in the AI Controller.

3-1	Function Overview	3-2
3-1-1	Frames and Subframes	3-2
3-1-2	Input Data for the Feature Value/Machine Learning Function	3-3
3-1-3	Output Data for the Feature Value/Machine Learning Function	3-3
3-1-4	AI Machine Learning Model	3-4
3-2	Details on Function	3-5
3-2-1	I/O Data	3-6
3-2-2	I/O data Timing	3-9
3-2-3	Data Structures	3-10
3-3	Status of the Feature Value/Machine Learning Function	3-11
3-3-1	Status	3-11
3-3-2	Checking Method	3-12
3-3-3	Change Method	3-12
3-4	General Specifications	3-14
3-5	Calculation Timing	3-15
3-6	Restrictions	3-16

3-1 Function Overview

The Feature Value/Machine Learning Function determines whether equipment events occur in the running status data (frame variables, variable data, and subframe variables) of the equipment in the Data Utilization Phase. It consists of the Feature Extraction Function and the Machine Learning Function.

The Feature Extraction Function calculates feature values*1 from data. Meanwhile, the Machine Learning Function determines whether equipment events occur from the calculated feature values.

The equipment event determination results are output to the Time Series Database Function and to the system-defined variables.

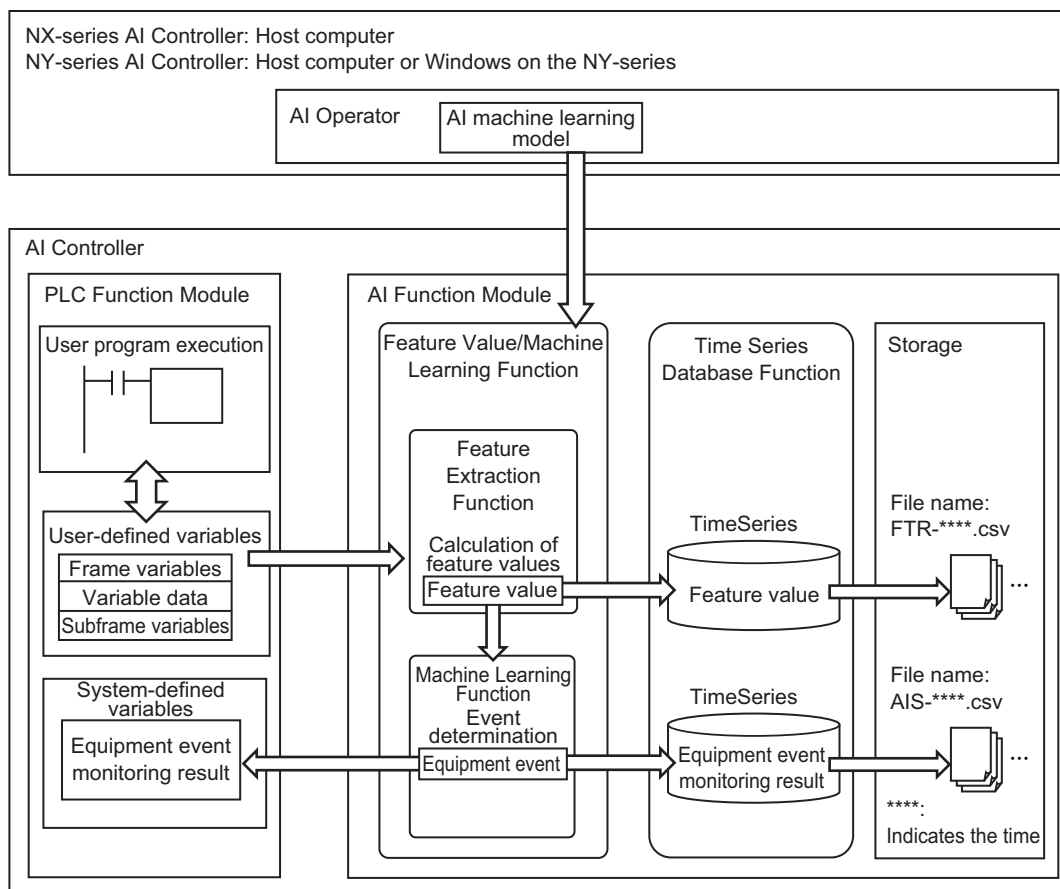

*1. The feature values refer to the quantified features and patterns that are generated from variable data within a certain time range based on the statistics.

3-1-1 Frames and Subframes

A frame is the range in which feature values are calculated by the Feature Extraction Function. It is also possible to identify a time range in which values are calculated within a frame, which is referred to as a subframe. The subframe setting is optional.

When the frame changes, the Feature Extraction Function calculates feature values from the variable data in the time frame specified with a subframe (or by a frame when subframe is not specified). Feature values are calculated for each variable data.

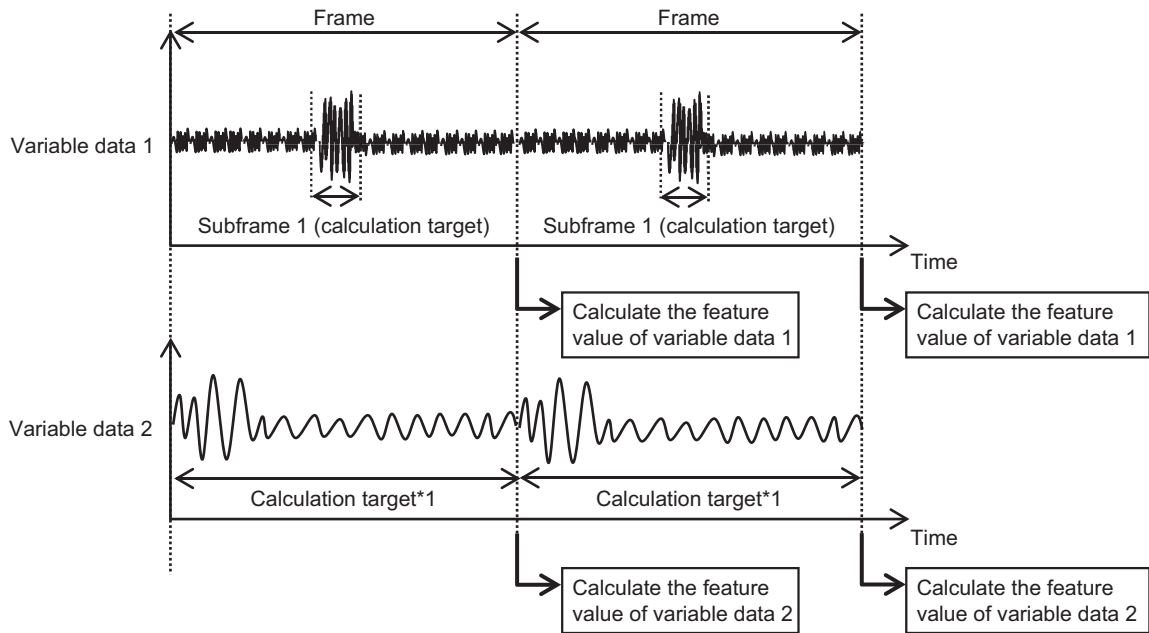

*1. Subframes are not set, so calculations will be performed on the frames. Specify a single movement of the equipment to fit within one frame. For a press machine that repeats the same movement, set a single press operation to one frame. To clarify the features, you need to specify an interval for the subframe within a frame. In the case of a press machine, for example, the subframe variable is used to specify the pressing interval if you determine the event at press operation.

3-1-2 Input Data for the Feature Value/Machine Learning Function

Input frame variables, variable data, and subframe variables to the Feature Value/Machine Learning Function.

Input data	Description
Frame variables	You can include a frame variable to the user program and write a value from the user program to specify a frame. The Feature Value/Machine Learning Function calculates a feature value when the value of the frame variable changes.
Variable data	Variables that are necessary for monitoring equipment events are specified as variable data. The Feature Value/Machine Learning Function identifies the characteristics of the variable data and monitors equipment events.
Subframe variables	You can include a frame variable to the user program and write a value from the user program to specify a subframe. The Feature Value/Machine Learning Function calculates feature values based on the variable data while the subframe variable (BOOL) is TRUE.

3-1-3 Output Data for the Feature Value/Machine Learning Function

The equipment event monitoring result, which was calculated by the Feature Value/Machine Learning Function, is output to the Time Series Database Function and to the system-defined variables.

The name of a file generated by the Time Series Database Function is *A/S-***.csv* (***) specifies the time) and the data can be visualized on the AI Viewer. In addition, the system-defined variables are output to the *Equipment Event Monitoring Result* (`_MLE_Result`).

3-1-4 AI Machine Learning Model

The AI machine learning model is required for the Feature Value/Machine Learning Function to perform calculation.

An engineer of OMRON generates the AI machine learning model in the Data Analysis Phase from the analysis data collected in the Data Collection Phase. In the Data Utilization Phase, you need to download the AI machine learning model to the AI Controller. This model is used for the Feature Value/Machine Learning Function to perform calculation of feature values and to determine equipment events.

Refer to *A-4 Processing in the Data Collection, Data Analysis, and Data Utilization Phases* on page A-28 for details on the AI machine learning model.

3-2 Details on Function

This section describes the function details of the Feature Value/Machine Learning Function. The Feature Value/Machine Learning Function executes processing in the following order from (1) through (4).

1. The Feature Extraction Function reads out variable data, frame variables, and subframe variables from the running equipment.
2. The feature value is calculated from the read data and AI machine learning model and is then written to the Time Series Database Function and to the system-defined variables.
3. The Machine Learning Function reads out the feature value.
4. Based on the read data and the AI machine learning model, the Machine Learning Function determines whether equipment events occur and writes them to the system-defined variables and to the Time Series Database Function as the equipment event monitoring results.

The equipment event monitoring results are comprised of the following:

- Equipment event monitoring score that shows the degree of the equipment event occurrence
- Judgment results of the equipment event level (Normal, Alarm Level 1, Alarm Level 2)

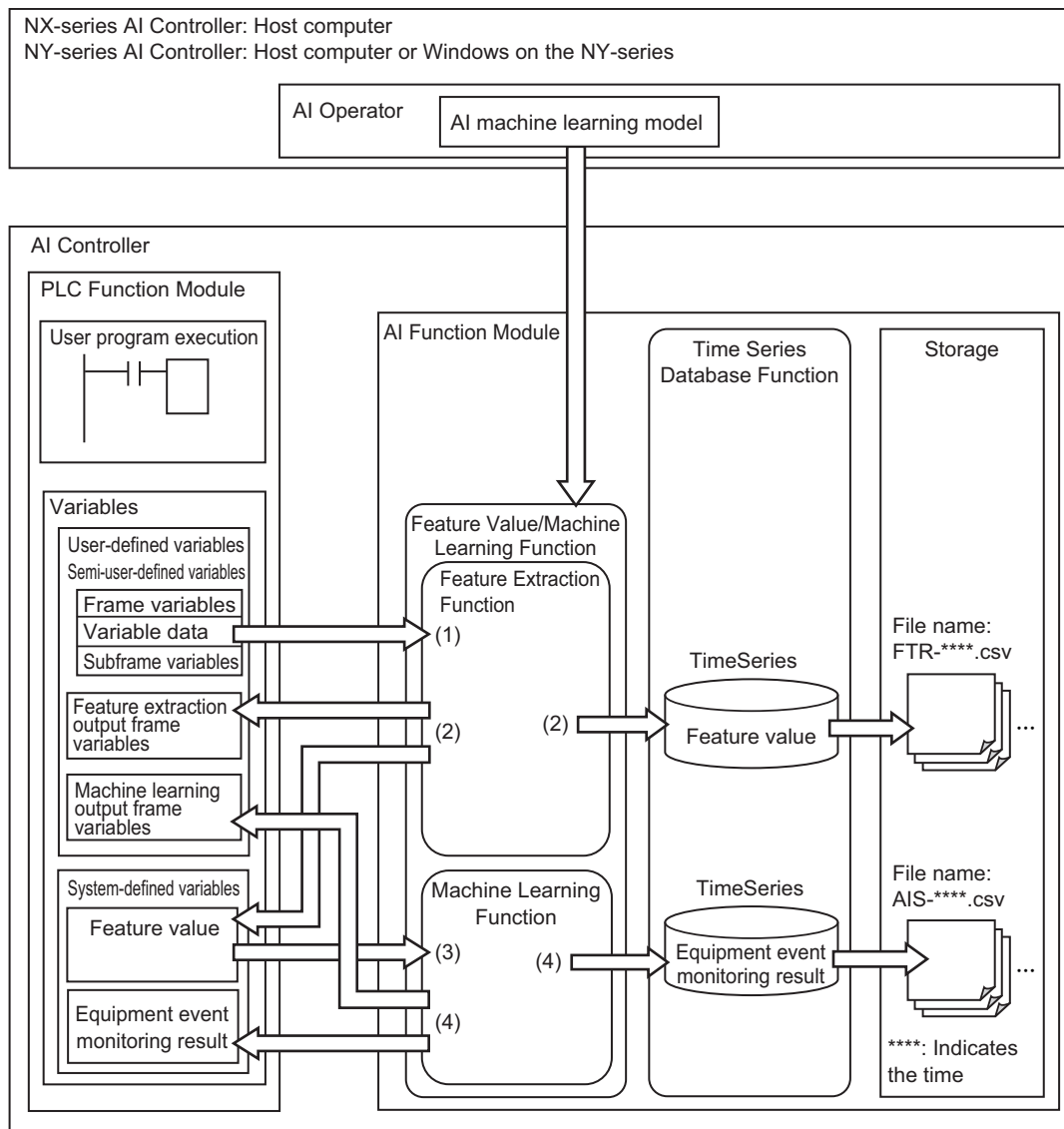

3-2-1 I/O Data

This section describes I/O data for the Feature Extraction Function and the Machine Learning Function.

Interfaces with the AI Operator

Function	Data name	Format	Description
Feature Value/ Machine Learning	AI machine learning model	File	This is the data required for determining if any equipment events occur in the running status data (frame variables, variable data, and subframe variables) of the equipment in the Data Utilization Phase. An engineer of OMRON generates an AI machine learning model from the analysis data collected in the Data Collection Phase. Download the provided model to your AI Controller.

Interfaces with the PLC Function Modules

Function	Data name	Type of variable	Data type	Variable type	Description
Feature Extraction	Frame variables	User-defined variables/Semi-user-defined variables/System-defined variables	SINT, INT, DINT, LINT, USINT, UINT, UDINT, ULINT	Global variable	The time interval (frame) that the Feature Extraction Function uses to calculate the feature value from variable data is specified by this variable. Feature values are calculated for each frame. A single frame is a time interval between the value change of this valuable and the next value change.
	Variable data	User-defined variables/Semi-user-defined variables/System-defined variables	LREAL, BOOL*1	Global variable	This variable is collected for determining if any equipment event occur. Specify a variable used for determining an equipment event. For example, enter a sensor value or a servo speed here.
	Subframe variables*2	User-defined variables/Semi-user-defined variables/System-defined variables	BOOL	Global variable	Use this variable to specify an interval (subframe) in the frame where the feature value is actually calculated. An interval in which this variable is TRUE is where the feature value is calculated. Create a user program for manipulating values of the subframe variables.
	Feature extraction output frame variables	User-defined variables*3	Same variable type that is set to the frame variables.	Global variable	The Feature Extraction Function outputs a value of the frame variable to this variable when the feature value is output. This allows users to check which frame the feature value belongs to.
Feature Value/Machine Learning	Feature value	System-defined variable (_FE_Result)	ARRAY [0..127, 0..15] OF_LREAL	---	This is a feature value calculated by the Feature Extraction Function. The Machine Learning Function uses the value of this variable. The first element of the array is an equipment event ID displayed on the Status Monitoring screen of the AI Viewer. The second element of the array is a feature value ID displayed on the Trend Graph screen of the AI Viewer.

Function	Data name	Type of variable	Data type	Variable type	Description
Machine Learning	Machine learning output frame variables	User-defined variables*4	Same variable type that is set to the frame variables.	Global variable	The Machine Learning Function outputs a value of the frame variable to this variable when the equipment event monitoring result is output. This allows users to check which frame the equipment event monitoring result belongs to.
	Equipment event monitoring result	System-defined variable (_MLE_Result)	ARRAY [0..127] OF_sMLE_RESULT*5	---	The Machine Learning Function outputs the determination result whether or not an equipment event occur. The array element correspond to the IDs of the equipment event list on the AI Operator.

- *1. When you set a non-LREAL or non-BOOL variable to the variable data, convert the variable to the LREAL data in the user program.
- *2. The settings of subframe variables are optional. It is also possible to skip the subframe variable settings from the AI Operator. In addition, subframe variables can be used for LREAL variable data. (Subframe variables cannot be used for the BOOL variable data.)
- *3. For the feature extraction output frame variables, specify variables that are different from *frame variables*, *machine learning output frame variables*, or *feature extraction output frame variables* for another equipment event.
- *4. For the machine learning output frame variables, specify variables that are different from *frame variables*, *feature extraction output frame variables*, or *machine learning output frame variables* for another equipment event.
- *5. For details on _MLE_Result, refer to *A-3 Specifications for Individual System-defined Variables* on page A-14 and *A-2 List of System-defined Variables* on page A-6.

Interfaces with the Time Series Database Function

Function	Data name	Description of data
Feature Extraction	Feature value	Calculates the feature value and outputs the value to the Time Series Database Function.
Machine learning	Equipment event monitoring result	Determines if there is any equipment event and outputs the event results to the Time Series Database Function.

3-2-2 I/O data Timing

The following timing chart shows the timing of I/O data from the Feature Value/Machine Learning Function.

The feature value is calculated based on the task period of primary periodic task that is the same timing when the frame variable is switched. The calculated value is then output to the system-defined variables (feature value).

Subsequently, determine if any equipment event occur after the next primary periodic task period, and then the value is output to the system-defined variables (equipment event monitoring result). The value of the frame variable specified in the user program is output to the feature value output frame variable and to the machine learning output frame variable.

Data shown in the figure such as "AAAA" is a value example used for description purposes.

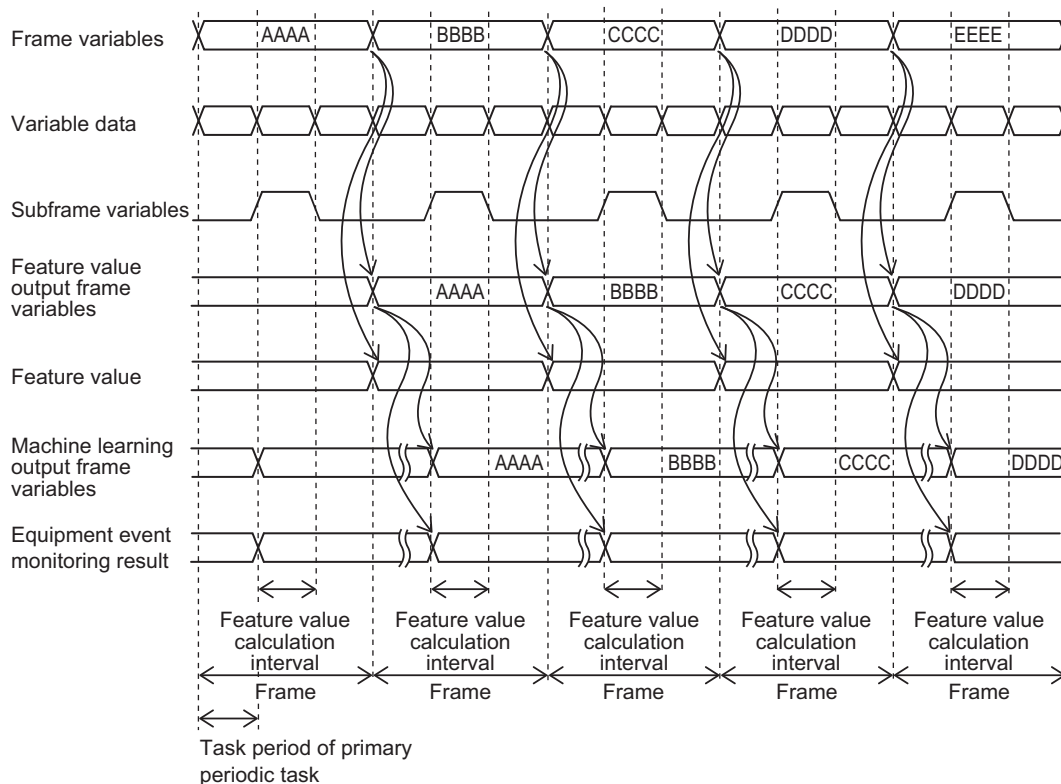

3-2-3 Data Structures

The structures of data that is input or output by the Feature Value/Machine Learning Function are as shown below.

Up to 128 equipment events can be registered.

For each equipment event, up to 16 feature values (up to 16 variable data and six subframe variables) can be specified.

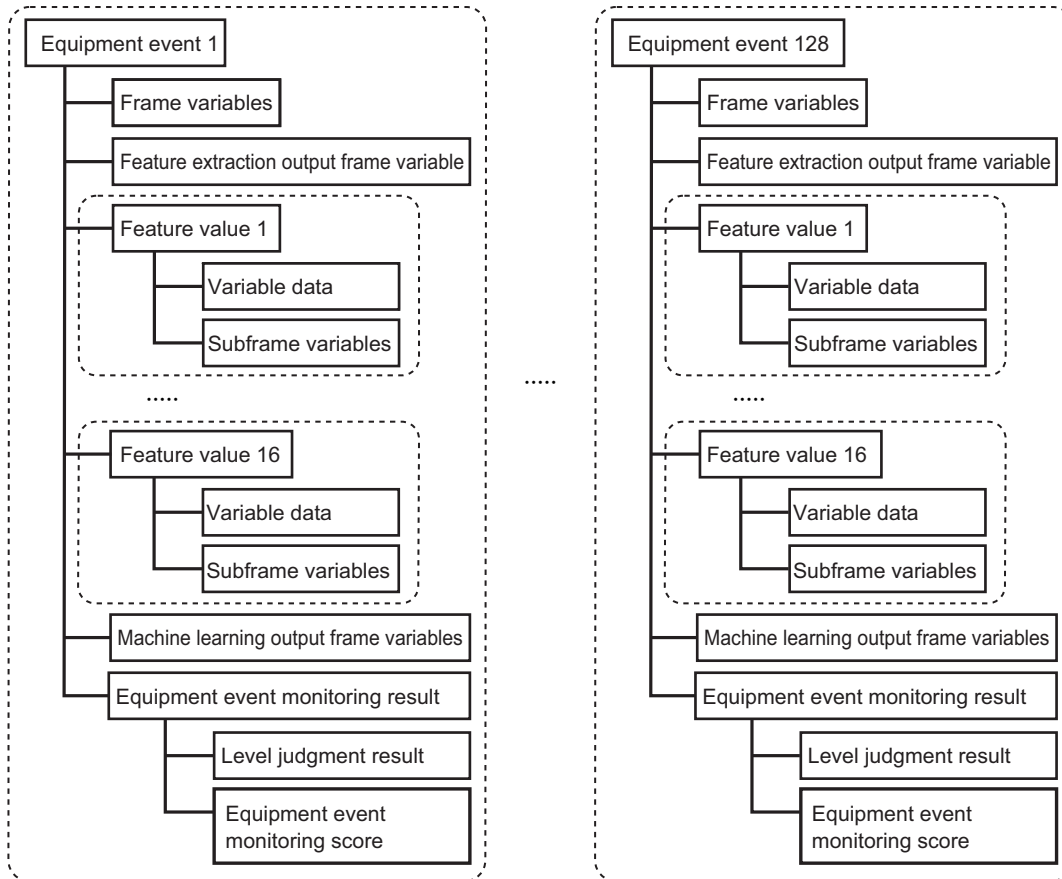

3-3 Status of the Feature Value/Machine Learning Function

3-3-1 Status

The Feature Extraction Function and the Machine Learning Function have the status described below.

Feature Extraction Function

Status	Description	Conditions for status transition
Initializing	The Feature Extraction Function is running after the AI Controller power is turned on.	During the AI Controller power-on or at the Controller reset time until the status changes to <i>Loading</i> status
Loading	The settings of the Feature Extraction Function are being loaded.	<ul style="list-style-type: none"> During the AI Controller power-on or at the Controller reset time until the status changes to <i>Idle</i> or <i>Error</i> status Settings are downloaded from Sysmac Studio or the AI Operator time until the status changes to <i>Idle</i> or <i>Error</i> status The restore for the backup functions is executed*¹ time until the status changes to <i>Idle</i> or <i>Error</i> status
Idle	The Feature Extraction Function is stopped.	<ul style="list-style-type: none"> System-defined variables or instructions by the AI Operator The operating mode of the AI Controller is PROGRAM mode When a major fault level error occurs
Running	The Feature Extraction Function is running.	System-defined variables or instructions by the AI Operator* ²
Error	The operation cannot be performed due to an error in the setting parameters of the Feature Extraction Function.	When an error occurs with the Feature Extraction Function

*1. The backup functions refer to the SD Memory Card backup function, the automatic transfer from SD Memory Card function, and the Sysmac Studio Controller Backups.

*2. The AI Controller must be in the RUN mode.

Machine Learning Function

Status	Description	Conditions for status transition
Initializing	The Machine Learning Function is running after the AI Controller power is turned on.	During the AI Controller power-on or at the Controller reset time until the status changes to <i>Loading</i> status

Status	Description	Conditions for status transition
Loading	The settings of the Machine Learning Function are being loaded.	<ul style="list-style-type: none"> During the AI Controller power-on or at the Controller reset time until the status changes to <i>Idle</i> or <i>Error</i> status Settings are downloaded from Sysmac Studio or the AI Operator time until the status changes to <i>Idle</i> or <i>Error</i> status The restore for the backup functions is executed*¹ time until the status changes to <i>Idle</i> or <i>Error</i> status
Idle	The Machine Learning Function is stopped.	<ul style="list-style-type: none"> System-defined variables or instructions by the AI Operator The operating mode of the AI Controller is PROGRAM mode When a major fault level error occurs
Running	The Machine Learning Function is running.	System-defined variables or instructions by the AI Operator* ²
Error	The operation cannot be performed due to an error in the setting parameters of the Machine Learning Function.	When an error occurs with the Machine Learning Function

*1. The backup functions refer to the SD Memory Card backup function, the automatic transfer from SD Memory Card function, and the Sysmac Studio Controller Backups.

*2. The AI Controller must be in the RUN mode.

3-3-2 Checking Method

You can check the status of the Feature Extraction Function and the Machine Learning Function from the system-defined variables.

Status	Feature Extraction Function Value of the <code>_FE_Status</code> system-defined variable	Machine Learning Function Value of the <code>_MLE_Status</code> system-defined variable
Running	<code>_FE_STATUS_RUN</code>	<code>_MLE_STATUS_RUN</code>
Idle	<code>_FE_STATUS_IDLE</code>	<code>_MLE_STATUS_IDLE</code>
Initializing	<code>_FE_STATUS_INITIALIZE</code>	<code>_MLE_STATUS_INITIALIZE</code>
Loading	<code>_FE_STATUS_LOAD</code>	<code>_MLE_STATUS_LOAD</code>
Error	<code>_FE_STATUS_PARAMETER_ERROR</code>	<code>_MLE_STATUS_PARAMETER_ERROR</code>

3-3-3 Change Method

The status of the Feature Extraction Function and the Machine Learning Function can be changed with the system-defined variables or on the AI Operator.

System-defined Variables

You can change the status to *Running* or *Idle* by assigning a value to the system-defined variables.

Status to Be Changed	Feature Extraction Function	Machine Learning Function
Running	<code>_FE_Enable := TRUE;</code>	<code>_MLE_Enable := TRUE;</code>

Status to Be Changed	Feature Extraction Function	Machine Learning Function
Idle	_FE_Enable := FALSE;	_MLE_Enable := FALSE;

AI Operator

The status can be changed by opening **Monitor/Operation - F.E./M.L. Function** screen on the AI Operator and selecting the **Enable** or **Disable** Button.

3-4 General Specifications

The general specifications of the Feature Value/Machine Learning Function are described below.

Item		Specifications		
Number of equipment events		128 max.		
In each equipment event	Frame variables	Number of variables that can be registered	1	
		Supported data type	SINT, INT, DINT, LINT, USINT, UINT, UDINT, ULINT	
	Feature extraction output frame variables	Number of variables that can be registered	1	
		Supported data type	Same types as the frame variables	
	Feature value		Number of variables that can be registered	16 max.
	Per feature value	Variable data	Number of variables that can be registered	1
			Supported data type	LREAL, BOOL
		Subframe variables	Number of variables that can be registered	1*1
			Supported data type	BOOL
	Machine learning output frame variables	Number of variables that can be registered	1	
		Supported data type	Same types as the frame variables	
	Number of classifications for equipment event monitoring		3 (Normal, Alarm Level 1, Alarm Level 2)	
Equipment event detection algorithm		isolation forest		

*1. Up to six subframe variables can be registered to an equipment event.

3-5 Calculation Timing

The Feature Extraction Function is executed in *system common processing 2* of the primary periodic task.

The Machine Learning Function is executed in *system service*.

For details on *system common processing 2* and *system service*, refer to the *NJ/NX-series CPU Unit Software User's Manual (Cat. No. W501)*.

3-6 Restrictions

The following restrictions apply to the Feature Value/Machine Learning Function.

- When the AI functions are added, the task execution time becomes longer because of the calculation performed by the Feature Value/Machine Learning Function. After you add the AI functions, make sure to perform the system evaluation. Note that *Execution Time Estimation Mode* of the Simulator on the Sysmac Studio is not supported.
- Use the AI machine learning model provided by an engineer of OMRON. If you change the file contents, it will not only prevent equipment events from being detected but also cause the AI Controller to generate an error.
- Equipment events are monitored based on past data. This means that equipment event monitoring results may differ according to physical changes in the equipment or changes in the environment.
- To ensure that equipment events are detected correctly, run the system to perform system evaluation. Depending on the AI Controller settings, equipment events may not be detected as you expected.
- To ensure that equipment events are detected correctly, when you reuse the AI machine learning model, run the system to perform system evaluation. Depending on differences between equipment, etc., equipment events may not be detected as you expected.
- Because the Machine Learning Function needs the calculation period, the equipment event determination result is not output in the same task period as the frame switching interval. Consider this aspect and perform the system evaluation.
- Data is recorded in a ring buffer of TimeSeries of the Time Series Database Function. Depending on the export period setting, feature values that were output to the TimeSeries and the old equipment event monitoring results may be overwritten.



Precautions for Correct Use

If you determine equipment events, make sure that both the Feature Extraction Function and the Machine Learning Function are *Running*.

4

WebAPI Connection Function

This section describes the WebAPI Connection Function that is installed in the AI Controller.

4

4-1	Function Overview	4-2
4-2	Status of the WebAPI Connection Service	4-4
4-2-1	Status.....	4-4
4-2-2	Checking Method	4-4
4-2-3	Change Method	4-4
4-3	File Transfer Execution Method	4-5
4-4	How to Import Certificates.....	4-6
4-5	Web Server Connection Check Function.....	4-7
4-5-1	Function Specifications.....	4-7
4-5-2	Application Method	4-7
4-6	Operation Processing of the WebAPI Connection Service	4-8
4-7	File Transfer Results	4-9
4-7-1	Transfer Results.....	4-9
4-7-2	Statistical Information	4-9
4-8	List of Settings	4-11
4-9	Restrictions	4-13

4-1 Function Overview

The WebAPI Connection Function transfers data (CSV files) collected by the Time Series Database Function from the AI Controller to the Web server periodically. You will use this function when you transfer data (CSV files) collected by the Time Series Database Function to the Web server and save and analyze the data.

Since the WebAPI Connection Function works by configuring the settings on the AI Operator, you do not prepare a user program to transfer files.

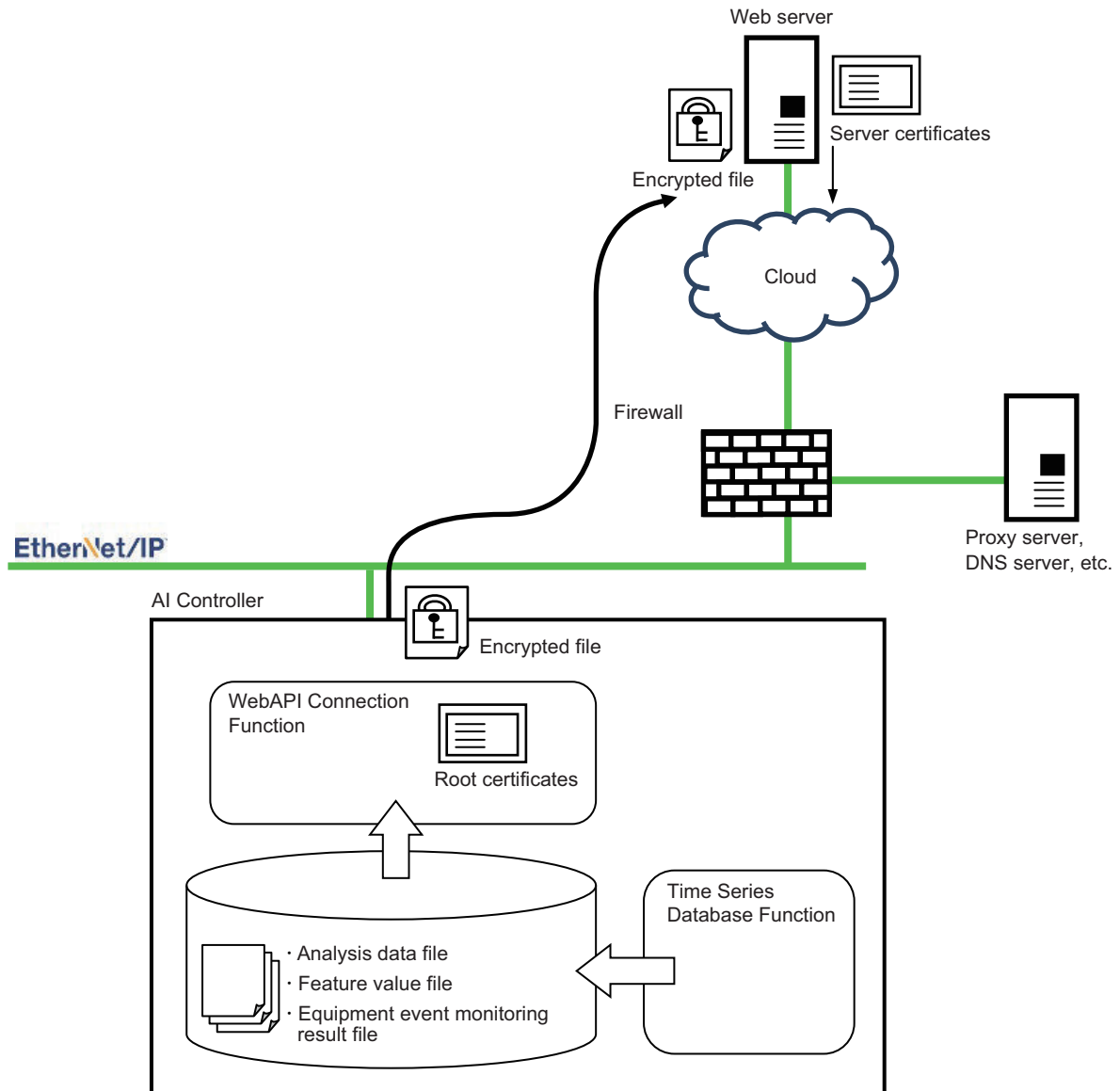

- If you specify an address starting with *https://* for the Web server address, you can establish SSL/TSL communications.
(You need to import the root certificate of the Web server to the AI Controller.)
- You can access the Web server via a proxy server.
- You can use a DNS server and specify the Web server address as a host name.



Precautions for Correct Use

To use the WebAPI Connection Function, you need to install or build a Web server.

The general specifications are as follows.

Item		Specifications	
Function specifications	Execution trigger	File transfer can be executed in the period specified by a user on the AI Operator.	
	Destination specification	Specify a URL of the server to which files are transferred. Specify a URL starting with <i>http://</i> or <i>https://</i> . When you specify <i>https://</i> , SSL/TLS communications are established.	
	File deletion after transfer	Once the file has been transferred to the Web server successfully, the WebAPI Connection Function deletes the file in the AI Controller.	
	Connection check function	To check the connection with the Web server, a file transfer can be triggered by the AI Operator at a given timing. Refer to <i>4-5 Web Server Connection Check Function</i> on page 4-7 for details.	
	Transfer specifications	If there is more than one file to transfer at the transfer timing, all the files are transferred. If the last file transfer is in progress and the next file transfer timing arrives, the execution of the last file transfer continues.	
	Transfer protocol	The file transfer executes in accordance with the RFC1867 procedures. The multipart/form-data in the form is used. The tag name "datafile" is used for the transfer.	
Communication specifications	HTTP/HTTPS client	Supported versions	1.1
		DNS	Supported
		Proxy	Supported
		Basic authentication	Supported (Basic authentication for the proxy server and Web server connection is supported.)
		Number of files that can be transferred simultaneously	3
	Security (when <i>https://</i> is specified for the address)	TLS version	1.0, 1.1, 1.2
		Server certificates	Import the certificates to the AI Controller with the AI Operator. Up to 32 certificates can be set
		Revocation check for the certificates	Revocation is checked by OSCP stapling.

4-2 Status of the WebAPI Connection Service

4-2-1 Status

The WebAPI connection service has the following status.

Status	Description	Conditions for status transition
Initializing	The WebAPI connection service was started but has not entered the idle state after the AI Controller is started.	<ul style="list-style-type: none"> During the AI Controller power-on or at the Controller reset time until the status changes to <i>Idle</i> status
Idle	The WebAPI connection service is stopped.	<ul style="list-style-type: none"> Commands by the AI Operator Shutdown of the AI Controller (NY-series) Controller reset of the AI Controller Downloading by Sysmac Studio Clear all memory Restore execution of the backup function *1
Running	The WebAPI connection service is running. (The file transfer is being executed.)	<ul style="list-style-type: none"> Commands by the AI Operator Setting the automatic activation of the WebAPI service to Yes
Error	The service cannot run due to errors (corruption of the volatile memory, etc.) of the WebAPI connection service.	<ul style="list-style-type: none"> When there is an error with the WebAPI connection service

*1. The backup functions refer to the SD Memory Card backup function, the automatic transfer from SD Memory Card function, and the Sysmac Studio Controller Backups.

4-2-2 Checking Method

You can check the status of the WebAPI connection service on the AI Operator.

The status can be checked by opening the **Monitor/Operation - WebAPI Connection Function** screen on the AI Operator and selecting **Status** for WebAPI connection service.

4-2-3 Change Method

You can change the status of the WebAPI connection service on the AI Operator.

The status can be modified by opening **Monitor/Operation - WebAPI Connection Function** screen on the AI Operator and selecting **Start** or **Stop** button.

4-3 File Transfer Execution Method

You can start and stop the file transfer in the following methods.

Item	Method	Use cases	Description
Start	Commands by the AI Operator	When file transfer is executed by a user instruction only for a certain period	When you open Monitor/Operation and the WebAPI Connection Function screen and click Start , the WebAPI connection service enters in the running state and executes file transfer in the specified period.
	Turning the AI Controller power on, resetting the Controller, or enabling automatic start after settings are changed	When file transfer is executed at all times while the AI Controller power is turned on	When you open WebAPI Connection - Basics - Service Settings and set the Automatic activation of Service setting to Yes the WebAPI connection service enters in the running state and executes file transfer in the specified period when the AI Controller power is turned on or after the Controller is reset.
Stop	Commands by the AI Operator	When file transfer is executed by a user instruction only for a certain period	When you open Monitor/Operation and the WebAPI Connection Function screen and click Stop , the WebAPI connection service enters in the idle state and stops the file transfer.

4-4 How to Import Certificates

When you specify *https://* to the server where you transfer files, you need to import the root certificate of the web server to the AI Controller so that the Controller can authenticate the web server. You can import the certificate to the AI Controller by selecting **WebAPI Connection - Certificate** screen on the AI Operator.

4-5 Web Server Connection Check Function

4-5-1 Function Specifications

This function is triggered from the AI Operator and executes a file transfer in a given timing in order to check connection between the WebAPI Connection Function of the AI Controller and the Web server. The function specifications are described below.

Item	Function specifications
Destination	The file is transferred to the destination URL that is set on the AI Operator.
Transfer file name	The file name format of a file to be transferred is as follows: WebAPI_UploadTest_<Connection No.>*1_<YYYYMMDDhhmmss>*2.csv (The file to be transferred is prepared by the system. Users do not need to create this file.)
Executable state	When the WebAPI connection service is in the idle or running state, the file transfer by this function can be executed.
Retry	The set value of connection retry is not used. A file transfer is executed once only.
Timeout	It runs in accordance with the set value of transfer timeout period.
Execution results	The execution results can be checked on the AI Operator. Refer to <i>4-8 List of Settings</i> on page 4-11 for details.
Operation after execution	When the file transfer succeeds while the File Upload Failed error is present, the error is cleared.

*1. This is the connection number assigned to the Web server to which data is transferred. (Numeric value from 01 to 03)

*2. This is the time information in the year, month, day, hour, minute, and second format.

4-5-2 Application Method

To execute this function, go to **Monitor/Operation - WebAPI Connection Function - File Upload** screen on the AI Operator, and then click **Confirm Cnct.**

4-6 Operation Processing of the WebAPI Connection Service

The WebAPI connection service runs in the system services of the AI Controller.

For details on the system services, refer to the *NJ/NX-series CPU Unit Software User's Manual (Cat. No. W501)* or the *NY-series Industrial Panel PC / Industrial Box PC Software User's Manual (Cat. No. W558)*.

4-7 File Transfer Results

4-7-1 Transfer Results

You can check the file transfer results for the three web servers that you registered by opening the **Monitor/Operation** screen on the AI Operator and by using **WebAPI Connection Function**. The meaning of the results you can check on the AI Operator is described below.

Results displayed on the AI Operator	Description
Disable	<ul style="list-style-type: none"> The WebAPI connection service settings are set to <i>Do not use</i> The WebAPI connection service is in the state other than running
Ready	The WebAPI connection service is enabled but file transfer was never executed <ul style="list-style-type: none"> There is no file to transfer Time that is set to the transfer period, is not reached yet.
Success	The last file transfer succeeded
Fault	The last file transfer failed

4-7-2 Statistical Information

Statistical information of the file transfer for each connection number can be checked on **Statistics - WebAPI Connection** screen on the AI Operator.

The meaning of the statistical information you can check on the AI Operator is described below.

Statistical information display of the AI Operator		Description
Transmission target	Number of files currently set as the transfer target	It is the number of files transferred in the Controller.
Transmission succeeded	Total transferred files	It is the total number of files that were successfully transferred to the server.
	Total transfer bytes	It is the total number of bytes for the files that were successfully transferred to the server.
	Total transfer time	It is the total transfer time for files that were successfully transferred to the server.
	The latest transfer start time	It is the start time of a last successful file transfer.
	The latest transfer completion time	It is the completion time of a last successful file transfer.
	Average transfer time of 1 file	It is the average value of the transfer time of a file that was successfully transferred to the server.
	Minimum transfer time of 1 file	It is the minimum value of the transfer time of a file that was successfully transferred to the server.
	Maximum transfer time of 1 file	It is the maximum value of the transfer time of a file that was successfully transferred to the server.
	Transfer time of the latest file	It is the transfer time of a last successful file transfer.
	Average transfer rate of 1 file	It is the average value of the transfer rate of a file that was successfully transferred.
	Minimum transfer rate of 1 file	It is the minimum value of the transfer rate of a file that was successfully transferred.
	Maximum transfer rate of 1 file	It is the maximum value of the transfer rate of a file that was successfully transferred.
	Transfer rate of the latest file	It is the transfer rate of a last successful file transfer.

Statistical information display of the AI Operator		Description
Transmission failed	Connection failed count	It is the number of failed connections with the Web, proxy, or DNS server.
	Transfer failed count	It is the number of times that the file transfer failed. (It does not include the number of failed connections.)
	Latest send error code	It is the error code of the last failed file transfer.
	The latest send error detection time	It is the detection time of the failure when the last file transfer failed.
	The latest send error recovery time	It is the recovery time from the failure when the last file transfer failed.

4-8 List of Settings

The settings for the WebAPI Connection Function are described below. These settings can be configured by the AI Operator.

● Service Settings

The AI Operator screen	Setting name	Description	Set value	Default	
WebAPI Connection Setting - Basics - Service Settings	Automatic activation of Service	Specify whether to start for the WebAPI connection service when the AI Controller starts running.	Yes/No	No	
	Proxy settings	Use	Specify whether to use a proxy server.	Yes/No	No
		Address (Host name)* ¹	Specify an IP address or host name of the proxy server.	128 characters or less (case sensitive)	---
		Port No.* ¹	Specify the destination port number of the proxy server.	1 to 65535	---
		Authentication* ¹	Specify if you use or do not use the basic authentication of your proxy server.	Yes/No	No
		User name* ¹ * ²	Specify a user name for your proxy server's basic authentication.	1 to 128 characters (case sensitive)	---
		Password* ¹ * ²	Specify a password for your proxy server's basic authentication.	1 to 128 characters (case sensitive)	---

*1. The setting is enabled when you use a proxy server.

*2. The setting is enabled when you use the basic authentication of the proxy server.

● File Upload Setting

Up to three sets of the following settings can be configured according to each TimeSeries.

The AI Operator screen	Setting name	Description	Set value	Default	
WebAPI Connection Setting - Basics - File Upload Settings	Use/Do not use	Specify whether to use the file upload function.	Yes/No	No	
	Send Data* ¹	Specify which TimeSeries' CSV file to transfer.	Analysis data (ANL_DATA)/Feature (FTR_DATA)/Equipment Event Monitoring Results (AIS_DATA)	---	
	URL* ¹	Specify a URL of the server to which files are transferred. Example: https://omron-sample.co.jp:8080/upload.php	256 characters (not case sensitive)	---	
	Transfer settings* ¹	Cycle [sec]	Specify a period for transferring files to the web server.	1 to 60	10
		Transfer timeout time [sec]	Specify a timeout period of the file transfer to the web server.	1 to 600	120
	Authentication settings* ¹	Authentication	Specify whether to use the basic authentication of the web server.	Yes/No	No
		User ID* ²	Specify a user name for the basic authentication.	1 to 128 characters (case sensitive)	---
		Password* ²	Specify a password for the basic authentication.	1 to 32 characters (case sensitive)	---
	Connection retry* ¹	Connection timeout time [sec]	Specify a timeout period.	1 to 60	20
		Number of retries	Specify the number of retries.	0 to 5	3
		Retry interval [sec]	Specify a retry interval.	1 to 60	3
	Security settings* ¹ * ³	TLS version	Specify a TLS version.	1.0 / 1.1 / 1.2	1.2
		Forwarding when server certificate expires	Specify whether to enable or disable file transfer when the server certificate is expired.	Yes/No	No
		OCSP stapling	Specify whether to enable or disable revocation check by OCSP stapling.	Yes/No	No

*1. The setting is enabled when you use the File Upload Function.

*2. The setting is enabled when you use the basic authentication of the web server.

*3. The setting is enabled when the web server uses the HTTPS protocol.

4-9 Restrictions

The following restrictions apply to the WebAPI Connection Function.

- Since this function is dependent on the network environment, the performance of the file transfer is not guaranteed. Make sure to conduct system verification in the user environment before you use this function in an actual environment.
- If the file export speed of the Time Series Database Function is faster than the file transfer speed of the WebAPI Connection Function, there is no free space of the storage in the AI Controller and the Time Series Database Function cannot export the file. Make sure to conduct system verification in the user environment before you use this function in an actual environment.
- In addition, if the file transfer to the Web server is compromised by problems such as when the Web server is stopped or a problem exists in the communication path, it could also cause a shortage of the storage space. When you use this function, make sure to consider this possibility.
- Up to three Web servers can be registered, but you cannot transfer a file to the separate Web servers.
- If you transfer files to a cloud-based Web server, make sure to implement security measures for the network, such as installing a proxy server and so on.

5

Time Series Database Instructions

This section describes specifications of the instructions used for the Time Series Database.

TimeSeries_ControlService.....	5-2
TimeSeries_ControlSampling	5-6
TimeSeries_ControlExport	5-8

TimeSeries_ControlService

The TimeSeries_ControlService instruction controls TSDB service status (start, stop, or shutdown).

Instruction	Name	FB/F UN	Graphic expression	ST expression
TimeSeries_ControlService	Control TSDB Service Status	FB		TimeSeries_ControlService_instance (Execute, Cmd, Done, Busy, Error, ErrorID);

Variables

Name	Meaning	I/O	Description	Valid range	Unit	Default
Cmd	Command	Input	Input a command to be executed. 1: Start command 2: Stop command 9: Shutdown command	1, 2, 9	---	0

Name	Boolean	Bit strings				Integers							Real numbers		Times, durations, dates, and text strings					
	BOOL	BYTE	WORD	DWORD	LWORD	USINT	UINT	UDINT	ULINT	SINT	INT	DINT	LINT	REAL	LREAL	TIME	DATE	TOD	DT	STRING
Cmd											OK									

Function

This instruction performs the *Start command*, *Stop command* or *Shutdown command* to the TSDB service.

This instruction ends normally if the TSDB service is already in the same status as the command, such as when *Start command* is input for *Cmd* while the TSDB service is *Running*.

Related System-defined Variables

Name	Meaning	Data type	Description
_TSDB_Status	TSDB Service Status	_sTSDB_STATUS	System-defined variable that shows the status of the TSDB service
_TSDB_ShutdownCmd	TSDB Service Shutdown Command	BOOL	When the variable changes from FALSE to TRUE, the shutdown command sends to the TSDB service.

Precautions for Correct Use

- Execution of this instruction is continued until processing is completed even if the value of *Execute* changes to FALSE or the execution time exceeds the task period. The value of *Done* changes to TRUE when processing is completed. Use this to confirm normal completion of processing.
- Refer to *Using this Section* in the *NJ/NX-series Instructions Reference Manual* (Cat. No. W502) for a timing chart of *Execute*, *Done*, *Busy*, and *Error*.
- You cannot use this instruction in an event task. A compiling error will occur.
- *Error* is TRUE if an error occurred. The meanings of the values of *ErrorID* are given in the following table.

ErrorID values	Error description
16#0400	The value of the <i>Cmd</i> is outside the valid range.
16#4C0C	There is not sufficient resources to execute the time series database instruction.
16#4C0D	While the TSDB service is in the <i>Error</i> or <i>Shutdown</i> state, the <i>Start command</i> or <i>Stop command</i> was executed.

Additional Information

If you run this instruction in the Simulator, when *Execute* changes from FALSE to TRUE, the values of output variables are shown in the table below.

Output variable	Normal input value	Abnormal input value
Done	TRUE	FALSE
Busy	FALSE	FALSE
Error	FALSE	TRUE
ErrorID	16#0000	16#0400

Sample Programming

This sample executes the *Shutdown command* for the TSDB service.

LD

Internal Variables	Variable	Data type	Initial value	Comment
	OperatingEnd	BOOL	FALSE	Processing completed
	Trigger	BOOL	FALSE	Execution condition
	Operating	BOOL	FALSE	Processing
	RS_instance	RS		
	IsExport	BOOL	FALSE	
	ControlService_instance	TimeSeries_ControlService		

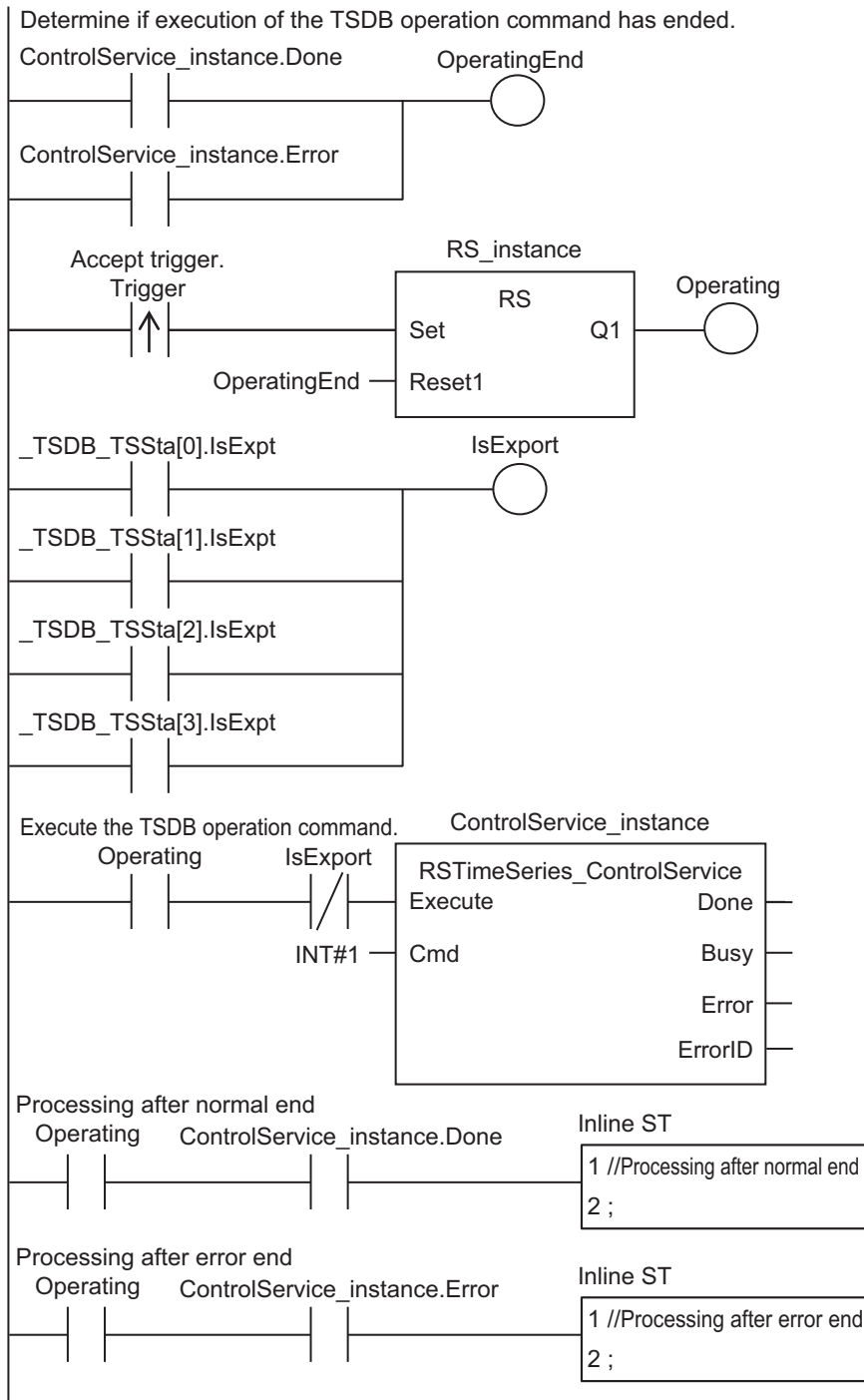

ST

Internal Variables	Variable	Data type	Initial value	Comment
	Trigger	BOOL	FALSE	Execution condition
	LastTrigger	BOOL	FALSE	Value of Trigger from previous task period
	OperatingStart	BOOL	FALSE	Processing started
	Operating	BOOL	FALSE	Processing
	IsExport	BOOL	FALSE	

Internal Variables	Variable	Data type	Initial value	Comment
	ControlService_instance	TimeSeries_ControlService		

```

// Detect when Trigger changes to TRUE.
IF ( (Trigger=TRUE) AND (LastTrigger=FALSE) ) THEN
    OperatingStart:=TRUE;
    Operating :=TRUE;
END_IF;
LastTrigger:=Trigger;
// Initialize TimeSeries_ControlService instruction
IF (OperatingStart=TRUE) THEN
    ControlService_instance (
        Execute :=FALSE,
        Cmd :=1);
    OperatingStart:=FALSE;
END_IF;
// Determination during the execution of export
IF ((_TSDB_TSSta[0].IsExpt=TRUE) OR (_TSDB_TSSta[1].IsExpt=TRUE) OR
    (_TSDB_TSSta[2].IsExpt=TRUE) OR (_TSDB_TSSta[3].IsExpt=TRUE)) THEN
    IsExport:=TRUE;
END_IF;
// Execute TimeSeries_ControlService instruction
IF ((Operating=TRUE)AND(IsExport=FALSE)) THEN
    ControlService_instance (
    Execute :=TRUE,
        Cmd:=INT#9);
    IF (ControlService_instance.Done=TRUE) THEN
        // Processing after normal end
        Operating:=FALSE;
    END_IF;
    IF (ControlService_instance.Error=TRUE) THEN
        // Processing after error end
        Operating:=FALSE;
    END_IF;
END_IF;
END_IF;

```

TimeSeries_ControlSampling

The TimeSeries_ControlSampling controls the sampling status for the specified TimeSeries.

Instruction	Name	FB/FUN	Graphic expression	ST expression
TimeSeries_ControlSampling	Control Sampling Status	FUN		Out:=TimeSeries_ControlSampling(TimeSeriesName,Cmd);

Variables

Name	Meaning	I/O	Description	Valid range	Unit	Default
TimeSeries-Name	Name of TimeSeries	Input	Enter any of the following TimeSeries names as a text string: <ul style="list-style-type: none"> 'RAW_DATA' 'ANL_DATA' 	64 bytes max. (Including the final NULL character)	---	"
Cmd	Command	Input	Input a command to be executed. 1: Start 2: Stop	1, 2	---	0
Out	Processing Result	Output	Store the processing result. 0: Normal end 6: Invalid Cmd 9: Invalid TimeSeries In any of the cases, ENO of the instruction will become TRUE.	Depends on the data type.	---	---

Name	Boo lean	Bit strings				Integers							Real numbers		Times, durations, dates, and text strings						
	BOOL	BYTE	WORD	DWORD	LWORD	USINT	UINT	UDINT	ULINT	SINT	INT	DINT	LINT	REAL	LREAL	TIME	DATE	TOD	DT	STRING	
TimeSeries-Name																					OK
Cmd										OK											
Out										OK											

Function

This instruction starts or stops sampling the TimeSeries specified for the *TimeSeriesName* according to the *Cmd* command.

Related System-defined Variables

Name	Meaning	Data type	Description
_TSDB_TSSta	TimeSeries Status	ARRAY[0..31] OF _sTSDB_TSSta*1	Output the TimeSeries status.
_TSDB_SmplStartCmd	Sampling Start Com- mand	ARRAY [0..31] OF BOOL*1	Instruct the TimeSeries to start sam- pling.
_TSDB_SmplStopCmd	Sampling Stop Com- mand	ARRAY [0..31] OF BOOL*1	Instruct the TimeSeries to stop sam- pling.

*1. The array element numbers mean the following:
0: RAW_DATA, 1: ANL_DATA, 2: FTR_DATA, 3: AIS_DATA, 4 to 31: Reserved

Precautions for Correct Use

An error occurs in the following cases. Identify the cause of the error based on the value of *Out*.

- The TimeSeries specified by the *TimeSeriesName* is not found.
- There is not sufficient resources to execute the instruction.

TimeSeries_ControlExport

The TimeSeries_ControlExport instruction starts and stops exporting the specified TimeSeries.

Instruction	Name	FB/FUN	Graphic expression	ST expression
TimeSeries_ControlExport	Control Export Status	FUN		Out:=TimeSeries_ControlExport(TimeSeriesName,Cmd);

Variables

Name	Meaning	I/O	Description	Valid range	Unit	Default
TimeSeries-Name	Name of TimeSeries	Input	Enter any of the following the TimeSeries names as a text string: <ul style="list-style-type: none"> 'RAW_DATA' 'ANL_DATA' 'FTR_DATA' 'AIS_DATA' 	64 bytes max. (Including the final NULL character)	---	"
Cmd	Command	Input	Input a command to be executed. 1: Start 2: Stop	1, 2	---	0
Out	Processing Result	Output	Store the processing result. 0: Normal end 6: Invalid Cmd 9: Invalid TimeSeries In any of the cases, ENO of the instruction will become TRUE.	Depends on the data type.	---	---

Name	Boo lean	Bit strings				Integers							Real num- bers		Times, durations, dates, and text strings					
	BOOL	BYTE	WORD	DWORD	LWORD	USINT	UINT	UDINT	ULINT	SINT	INT	DINT	LINT	REAL	LREAL	TIME	DATE	TOD	DT	STRING
TimeSeries-Name																				OK
Cmd											OK									
Out											OK									

Function

This instruction starts or stops exporting the TimeSeries specified for the *TimeSeriesName* according to the *Cmd* command.

Related System-defined Variables

Name	Meaning	Data type	Description
_TSDB_TSSSta	TimeSeries Status	ARRAY[0..31] OF _sTSDB_TSSSta*1	Output the TimeSeries status.
_TSDB_ExptStartCmd	Export Start Command	ARRAY [0..31] OF BOOL*1	Instruct the TimeSeries to start exporting.
_TSDB_ExptStopCmd	Export Stop Command	ARRAY [0..31] OF BOOL*1	Instruct the TimeSeries to stop exporting.

*1. The array element numbers mean the following:
0: RAW_DATA, 1: ANL_DATA, 2: FTR_DATA, 3: AIS_DATA, 4 to 31: Reserved

Precautions for Correct Use

An error occurs in the following cases. Identify the cause of the error based on the value of *Out*.

- The TimeSeries specified by the *TimeSeriesName* is not found.
- There is not sufficient resources to execute the instruction.

6

Startup Procedures for the AI Controller

This section describes the procedure to start the AI Controller. It describes the overview of startup procedures, and then describes them in detail.

6-1	Overview of Startup Procedures	6-2
6-2	Preliminary Preparation Phase	6-6
6-3	Data Collection Phase	6-8
6-4	Data Analysis Phase	6-14
6-5	Data Utilization Phase.....	6-15
6-6	Using Extension Function.....	6-25
6-6-1	WebAPI Connection Function.....	6-25
6-6-2	Variable Data Collection.....	6-28

6-1 Overview of Startup Procedures

The AI Controller startup procedure is as follows.

Phase	Step	Procedure	Used software			Related functions			Reference	
			Sysmac Studio	AI Operator	AI Viewer	Time Series Database Function	Feature Value/Machine Learning Function	WebAPI Connection Function		
Preliminary Preparation	Step 1 Determining equipment events/variables to monitor	1-1 Determining equipment events to monitor	---	---	---	---	---	---	page 6-6	
		1-2 Analyzing cause of equipment event	---	---	---	---	---	---	page 6-6	
	Step 2 Preparing the AI Controller	2-1 Preparing the AI Controller	---	---	---	---	---	---	page 6-6	
	Step 3 Downloading user program and FTP server function settings from the Sysmac Studio	3-1 Setting variables to use in AI functions to the user program	○	---	---	---	---	---	---	page 6-6
		3-2 Setting the FTP server function	○	---	---	---	---	---	---	page 6-7
		3-3 Downloading to the AI Controller	○	---	---	---	---	---	---	page 6-7



Phase	Step	Procedure	Used software			Related functions			Reference
			Sysmac Studio	AI Operator	AI Viewer	Time Series Database Function	Feature Value/Machine Learning Function	WebAPI Connection Function	
Data Collection	Step 4 Connecting the AI Controller with a computer	4-1 Connecting the AI Controller with a computer	---	---	---	---	---	---	page 6-8
	Step 5 Common settings in the AI Operator	5-1 Setting the project name	---	○	---	---	---	---	page 6-8
		5-2 Setting the model of the connected AI Controller	---	○	---	---	---	---	page 6-8
		5-3 Setting the FTP client of the AI Operator	---	○	---	---	---	---	page 6-8
	Step 6 Setting variable data	6-1 Registering variable data to the AI Operator	---	○	---	---	---	---	page 6-9
	Step 7 Setting equipment events	7-1 Setting equipment event names	---	○	---	---	---	---	page 6-10
		7-2 Setting variable data	---	○	---	---	---	---	page 6-10
		7-3 Setting frame variables	---	○	---	---	---	---	page 6-10
		7-4 Setting subframe variables	---	○	---	---	---	---	page 6-10
		7-5 Setting feature extraction output frame variables	---	○	---	---	---	---	page 6-10
		7-6 Setting machine learning output frame variables	---	○	---	---	---	---	page 6-10
		7-7 Downloading to the AI Controller	---	○	---	---	---	---	page 6-10
	Step 8 Starting data collection	8-1 Starting data collection	---	○	---	○	---	---	page 6-12
Step 9 Checking collected data for missing or omitted data	9-1 Checking collected data for missing or omitted data	---	---	---	---	---	---	page 6-12	
Step 10 Stopping data collection	10-1 Stopping data collection	---	○	---	○	---	---	page 6-13	



Phase	Step	Procedure	Used software			Related functions			Reference
			Sysmac Studio	AI Operator	AI Viewer	Time Series Database Function	Feature Value/Machine Learning Function	WebAPI Connection Function	
Data Analysis	Step 11 Generating and downloading the AI machine learning model	11-1 Generating and downloading the AI machine learning model	---	○	---	---	---	---	page 6-14



Phase	Step	Procedure	Used software			Related functions			Reference
			Sysmac Studio	AI Operator	AI Viewer	Time Series Database Function	Feature Value/Machine Learning Function	WebAPI Connection Function	
Data Utilization	Step 12 Connecting the AI Controller with a computer	12-1 Connecting the AI Controller with a computer	---	---	---	---	---	---	page 6-15
	Step 13 Creating programs	13-1 Creating the Feature Value/Machine Learning Function program	○	---	---	---	---	---	page 6-15
		13-2 Creating the Time Series Database program	○	---	---	---	---	---	page 6-16
	Step 14 Connecting the AI Controller with a computer	14-1 Connecting the AI Controller with a computer	---	---	---	---	---	---	page 6-16

Phase	Step	Procedure	Used software			Related functions			Reference
			Sysmac Studio	AI Operator	AI Viewer	Time Series Database Function	Feature Value/Machine Learning Function	WebAPI Connection Function	
	Step 15 Starting the transfer of CSV files from the AI Controller to the AI Operator	15-1 Starting the transfer of CSV files from the AI Controller to the AI Operator	---	○	---	---	---	---	page 6-17
		15-2 Starting the transfer of CSV files from the AI Controller to the Web server	---	---	---	---	---	○	page 6-17
	Step 16 Starting device operation	16-1 Starting device operation	---	---	---	---	---	---	page 6-17
	Step 17 Checking the AI function operation	17-1 Checking that collection status is running	---	○	---	○	○	---	page 6-18
		17-2 Checking that Feature Value/Machine Learning Function status is running	---	○	---	○	○	---	page 6-19
		17-3 Checking that frame variables/variable data/subframe variables are being written	○	---	---	○	○	---	page 6-19
		17-4 Checking collected data for missing or omitted data	---	---	---	---	---	---	page 6-20
	Step 18 Visualizing with the AI Viewer	18-1 Setting project names	---	---	○	○	○	---	page 6-20
		18-2 Importing the AI Controller project to monitor equipment events	---	---	○	○	○	---	page 6-21
		18-3 Displaying the Status Monitoring screen	---	---	○	○	○	---	page 6-21
		18-4 Displaying equipment event log	---	---	○	○	○	---	page 6-22
		18-5 Displaying the Trend Graph	---	---	○	○	○	---	page 6-22
	Step 19 Stopping device operation	19-1 Stopping device operation	---	---	---	---	---	---	page 6-22
	Step 20 Stopping the transfer of CSV files from the AI Controller to the AI Operator	20-1 Stopping the transfer of CSV files from the AI Controller to the AI Operator	---	○	---	---	---	---	page 6-23
		20-2 Stopping the transfer of CSV files from the AI Controller to Web server	---	○	---	---	---	○	page 6-23
	Step 21 Powering off the AI Controller	21-1 Shutting down the TSDB service	---	○	---	○	---	---	page 6-24
		21-2 Powering off the AI Controller	---	---	---	---	---	---	page 6-24

6-2 Preliminary Preparation Phase

Use the following procedure for the Preliminary Preparation Phase.

Step		User tasks
Step 1 Determining equipment events/variables to monitor	Step 1-1 Determining equipment events to monitor	Determine equipment events to monitor. An example of an equipment event is "To perform predictive maintenance for ○○ error in equipment". Up to 128 equipment events can be registered in the AI Controller.
	Step 1-2 Analyzing cause of equipment event	Analyze the parameters needed to determine equipment events and identify variables for the AI Controller. For example, a sensor value or a servo speed is required to determine equipment events. Install devices (such as a sensor) used to determine equipment events if it is not installed yet. Specify the variables identified here as the <i>variable data</i> in the AI Controller in Step 3-3. Up to 16 variable data can be specified per equipment event.
Step 2 Preparing the AI Controller	Step 2-1 Preparing the AI Controller	<ul style="list-style-type: none"> Prepare the AI Controller and connect it to the computer where the Sysmac Studio is installed. For details on the AI Controller models, refer to <i>Section 1 Overview and Features</i> on page 1-1. For an NX-series AI Controller, make sure that an SD memory card is inserted. For an NY-series AI Controller, make sure that an expanded storage (SSD) is inserted in drive bay A.
Step 3 Downloading user program and FTP server function settings from the Sysmac Studio	Step 3-1 Setting variables to use in AI functions to the user program	<p>Set the following variables required to use AI functions in user programs. Register them as global variables. (You can specify any variable name) Refer to <i>Section 3 Feature Value/Machine Learning Function</i> on page 3-1 for the explanation of each variable.</p> <ul style="list-style-type: none"> Frame variables Variable data Subframe variables Feature extraction output frame variables Machine learning output frame variables <p>Also, input values of <i>frame variables</i>, <i>variable data</i>, and <i>subframe variables</i> from the user program. Do not input <i>feature extraction output frame variables</i> and <i>machine learning output frame variables</i> from the user program because the Feature Value/Machine Learning Function of the AI Controller uses them.</p>

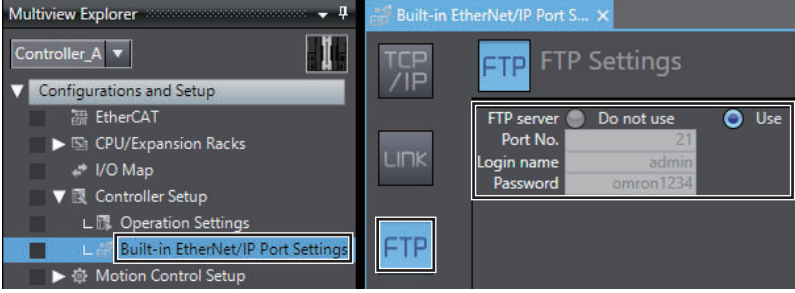
Step	User tasks
<p>Step 3-2 Setting the FTP server function</p>	<p>Set the FTP server on the AI Controller.</p> <p>You need to enable the FTP server settings because the AI Operator obtains files from the AI Controller using FTP communications. Select Controller Setup - Built-in EtherNet/IP Port Settings on the Sysmac Studio.</p> <p>Make the following settings on the FTP Dialog.</p> <ul style="list-style-type: none"> • Set FTP server to Use. • Set Port No. to the port number used for the FTP server. • Set Login name to the login name for the FTP server. (Example: admin) • Set Password to the password for the FTP server. (Example: omron1234) 
<p>Step 3-3 Downloading to the AI Controller</p>	<p>Download the settings you set in Step 3-1 and Step 3-2 to the AI Controller.</p>

6-3 Data Collection Phase

The procedure to start the data collection phase is as follows:

In this phase, analysis data is collected to the AI Controller with the Time Series Database Function of the AI Controller while the equipment is running.

The analysis data collected by the AI Controller is retrieved into your computer with the AI Operator.

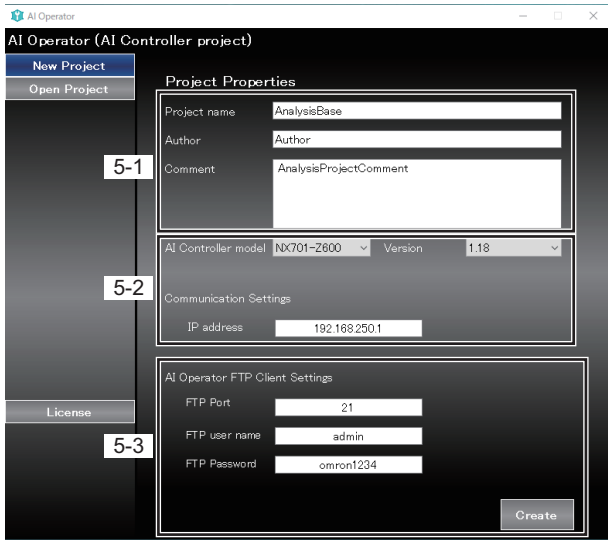
Step	User tasks
Step 4 Connecting the AI Controller with a computer	Step 4-1 Connecting the AI Controller with a computer Use Ethernet cables to connect the AI Controller with the computer where the AI Operator is installed. (When you install the AI Operator to Windows for an NY-series AI Controllers, you are not required to use cable connections.) At this time, use the same domain for the computer's IP address and the AI Controller's IP address.
Step 5 Common settings in the AI Operator	Start the AI Operator and perform Step 5-1 through 5-3. 
Step 5-1 Setting the project name	Set up a project on the AI Operator. These settings can be left as default. <ul style="list-style-type: none"> Specify Project name. Specify Author. Enter Comment.
Step 5-2 Setting the model of the connected AI Controller	Specify a model of the connected AI Controller. <ul style="list-style-type: none"> Select an AI Controller model from AI Controller model. Select an AI Controller version from Version. Specify an IP address of the AI Controller for IP address.
Step 5-3 Setting the FTP client of the AI Operator	Specify the FTP client settings for the AI Operator. Enter the same FTP server settings specified on the AI Controller in Step 3-2. <ul style="list-style-type: none"> Specify an FTP Port Specify a port number that the AI Controller opened for the FTP server. Specify an FTP user name. Specify a user name for the FTP server settings of the AI Controller. Specify an FTP Password. Specify a password for the FTP server settings of the AI Controller. <p>Press the Create Button.</p>

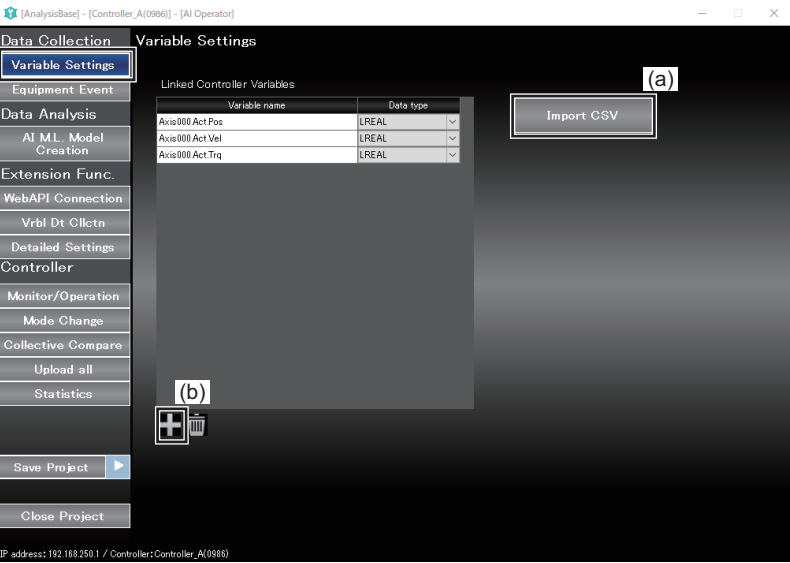
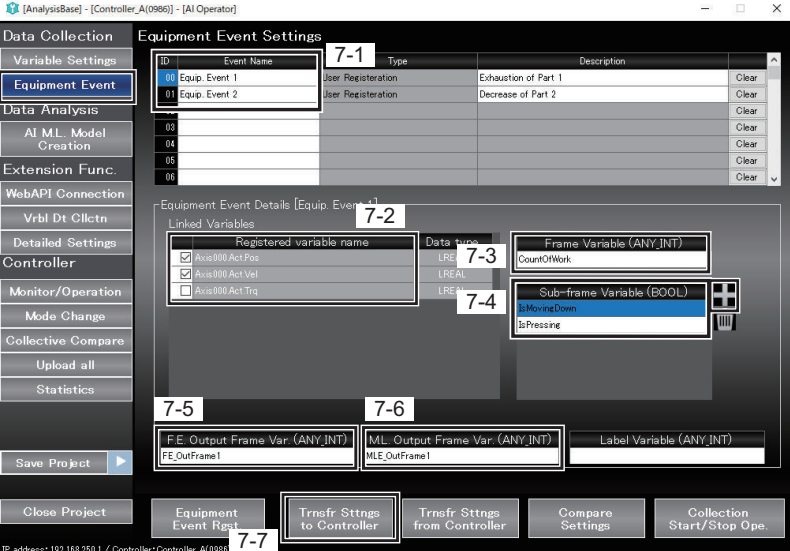
Step		User tasks
<p>Step 6 Setting variable data</p>	<p>Open the Variable Settings screen and perform Step 6-1.</p>	<p>Press the Variable Settings Button on the AI Operator to open the Variable Settings screen.</p> 
	<p>Step 6-1 Registering variable data to the AI Operator</p>	<p>There are two methods to register variable data into the AI Operator: (a) and (b). For the variable data, specify the variables downloaded to the AI Controller in Step 3.</p> <ol style="list-style-type: none"> Importing from Sysmac Studio to the AI Operator by using a CSV file <ul style="list-style-type: none"> Select variables specified in the variable table in the Sysmac Studio. Copy and paste them to the spreadsheet software. Save the file in the CSV format at any location in the computer and exit the spreadsheet software. Press the Import CSV Button on the AI Operator. When the file selection dialog appears, select the saved file. Entering variable names directly in the AI Operator <ul style="list-style-type: none"> Press the + Button on the AI Operator, and specify Variable name and Data type. <p>* If there is more than one variable, register all the variables.</p>
<p>Step 7 Setting equipment events</p>	<p>Open the Equipment Event Settings screen and perform Step 7-1 through 7-7.</p>	<p>Press the Equipment Event Settings Button on the AI Operator to open the Equipment Event Settings screen.</p> 

Step	User tasks
Step 7-1 Setting equipment event names	Name the equipment event that you decided in Step 1-1 and specify it for Event Name . Select an equipment event ID after the setting. Up to 128 equipment events can be registered in the AI Controller.
Step 7-2 Setting variable data	Select a check box of the variable data used for the equipment event. If there is more than one data, select them all. Up to 16 variable data can be specified per equipment event. (Among the variable data specified in Step 6, those in the LREAL or BOOL data are displayed.)
Step 7-3 Setting frame variables	Specify Frame Variable . Specify the frame variables that you downloaded to the AI Controller in Step 3. A frame is the time range in which feature values are calculated by the Feature Value/Machine Learning Function.
Step 7-4 Setting subframe variables	Specify Sub-frame variable . Specify the subframe variables that you downloaded to the AI Controller in Step 3. A subframe is the more detailed time range that is targeted for calculation within a frame. * The settings of subframe variables are not required. * If there is more than one, you can register them by pressing the + Button. * Up to six subframe variables can be registered to an equipment event.
Step 7-5 Setting feature extraction output frame variables	Specify F.E. Output Frame Var. . Specify the feature extraction output frame variables that you downloaded to the AI Controller in Step 3.
Step 7-6 Setting machine learning output frame variables	Specify M.L. Output Frame Var. . Specify the machine learning output frame variables that you downloaded to the AI Controller in Step 3. If there is more than one equipment event, go back to Step 7-1. Once you finish configuring all the equipment events, go to Step 7-7.
Step 7-7 Downloading to the AI Controller	Press the Trnsfr Sttns to Controller Button.

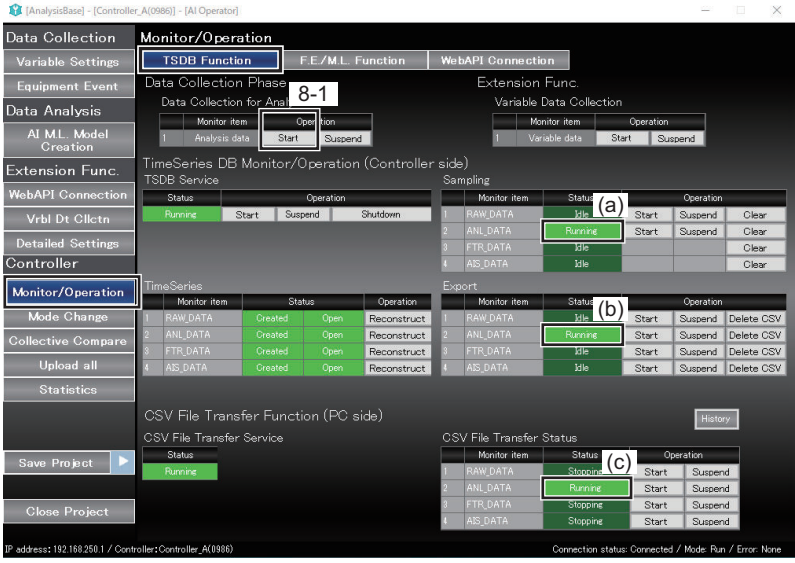
Step	User tasks																																																	
<p>Step 8 Starting data collection</p> <p>Open the Monitor/Operation screen and perform Step 8-1.</p>	<p>In this step, the collection (the following three operations) of analysis data (ANL-****.csv) is started.</p> <ul style="list-style-type: none"> Starting the sampling of the Time Series Database Function Starting the export of the Time Series Database Function Starting the transfer of CSV files from the AI Controller to the AI Operator <p>Click the Monitor/Operation - TSDB Function Buttons on the AI Operator to display the Monitor/Operation screen.</p>  <p>The screenshot shows the following data tables:</p> <table border="1"> <caption>Data Collection for Analysis</caption> <thead> <tr> <th>Monitor item</th> <th>Operation</th> </tr> </thead> <tbody> <tr> <td>1 Analysis data</td> <td>Start</td> </tr> </tbody> </table> <table border="1"> <caption>TimeSeries DB Monitor/Operation (Controller side)</caption> <thead> <tr> <th>Monitor item</th> <th>Status</th> <th>Operation</th> </tr> </thead> <tbody> <tr> <td>1 RAW_DATA</td> <td>Idle (a)</td> <td>Start</td> </tr> <tr> <td>2 ANL_DATA</td> <td>Running</td> <td>Suspend</td> </tr> <tr> <td>3 FTR_DATA</td> <td>Idle</td> <td>Start</td> </tr> <tr> <td>4 AIS_DATA</td> <td>Idle</td> <td>Start</td> </tr> </tbody> </table> <table border="1"> <caption>Export</caption> <thead> <tr> <th>Monitor item</th> <th>Status</th> <th>Operation</th> </tr> </thead> <tbody> <tr> <td>1 RAW_DATA</td> <td>Idle (b)</td> <td>Start</td> </tr> <tr> <td>2 ANL_DATA</td> <td>Running</td> <td>Suspend</td> </tr> <tr> <td>3 FTR_DATA</td> <td>Idle</td> <td>Start</td> </tr> <tr> <td>4 AIS_DATA</td> <td>Idle</td> <td>Start</td> </tr> </tbody> </table> <table border="1"> <caption>CSV File Transfer Status</caption> <thead> <tr> <th>Monitor item</th> <th>Status</th> <th>Operation</th> </tr> </thead> <tbody> <tr> <td>1 RAW_DATA</td> <td>Stopping (c)</td> <td>Start</td> </tr> <tr> <td>2 ANL_DATA</td> <td>Running</td> <td>Suspend</td> </tr> <tr> <td>3 FTR_DATA</td> <td>Stopping</td> <td>Start</td> </tr> <tr> <td>4 AIS_DATA</td> <td>Stopping</td> <td>Suspend</td> </tr> </tbody> </table>	Monitor item	Operation	1 Analysis data	Start	Monitor item	Status	Operation	1 RAW_DATA	Idle (a)	Start	2 ANL_DATA	Running	Suspend	3 FTR_DATA	Idle	Start	4 AIS_DATA	Idle	Start	Monitor item	Status	Operation	1 RAW_DATA	Idle (b)	Start	2 ANL_DATA	Running	Suspend	3 FTR_DATA	Idle	Start	4 AIS_DATA	Idle	Start	Monitor item	Status	Operation	1 RAW_DATA	Stopping (c)	Start	2 ANL_DATA	Running	Suspend	3 FTR_DATA	Stopping	Start	4 AIS_DATA	Stopping	Suspend
Monitor item	Operation																																																	
1 Analysis data	Start																																																	
Monitor item	Status	Operation																																																
1 RAW_DATA	Idle (a)	Start																																																
2 ANL_DATA	Running	Suspend																																																
3 FTR_DATA	Idle	Start																																																
4 AIS_DATA	Idle	Start																																																
Monitor item	Status	Operation																																																
1 RAW_DATA	Idle (b)	Start																																																
2 ANL_DATA	Running	Suspend																																																
3 FTR_DATA	Idle	Start																																																
4 AIS_DATA	Idle	Start																																																
Monitor item	Status	Operation																																																
1 RAW_DATA	Stopping (c)	Start																																																
2 ANL_DATA	Running	Suspend																																																
3 FTR_DATA	Stopping	Start																																																
4 AIS_DATA	Stopping	Suspend																																																

	Step	User tasks
	Step 8-1 Starting data collection	<p>Go to Data Collection Phase - Data Collection for Analysis and press the Start Button.</p> <p>This will start the sampling/export of the Time Series Database Function and the transfer by the AI Operator.</p> <p>You can check that the collection has started by the following items:</p> <ol style="list-style-type: none"> Sampling status of the Time Series Database Function: Sampling of No.2 (ANL_DATA) Status is Running Export status of the Time Series Database Function: Export of No.2 (ANL_DATA) Status is Running Transfer status by the AI Operator: CSV File Transfer Status of No.2 (ANL_DATA) Status is Running <p>The analysis data file (ANL-****.csv) is transferred to the following folder in the computer where the AI Operator is installed.</p> <div style="border: 1px solid black; padding: 5px; width: fit-content;"> C:\OMRON\CSVData\[Controller_Serial_No.]\ANL_DATA\YYYY\MM\dd\ (YYYY: Year/MM: Month/dd: Day) </div> <p>[Reference]</p> <p>You can also use the time series database instructions to send a sampling/export start command for the Time Series Database Function.</p> <p>Execute the following instructions in the user program.</p> <p>Export: Execute the TimeSeries_ControlExport instruction with the following input variables.</p> <p style="padding-left: 20px;">TimeSeries input variable: 'ANL_DATA'</p> <p style="padding-left: 20px;">Cmd input variable: INT#1</p> <p>Sampling: Execute the TimeSeries_ControlSampling instruction with the following input variables.</p> <p style="padding-left: 20px;">TimeSeries input variable: 'ANL_DATA'</p> <p style="padding-left: 20px;">Cmd input variable: INT#1</p>
Step 9 Checking collected data for missing or omitted data	Step 9-1 Checking collected data for missing or omitted data	<p>Check to see if the analysis data file (FTR-****.csv) has been transferred to the following folder in a computer where the AI Operator is installed and contact an engineer of OMRON.</p> <div style="border: 1px solid black; padding: 5px; width: fit-content;"> C:\OMRON\CSVData\[Controller_Serial_No.]\ANL_DATA\YYYY\MM\dd\ (YYYY: Year/MM: Month/dd: Day) </div> <p>Open the CSV file and check the Idx (index) field values to see if there is no irregular increment.</p> <p>If there is any missing Idx (index) field value, take any of the following measures.</p> <ul style="list-style-type: none"> • Reduce the volume of variables (size and number of variables) to collect. • Increase the task period of the primary periodic task. • Increase the export period. • Secure the execution time for the system services. <p>* For details on the CSV file format, refer to <i>A-5 CSV File Format</i> on page A-32.</p>

Step		User tasks																																													
Step 10 Stopping data collection	Open the Monitor/Operation screen and perform Step 10-1.	<p>In this step, the collection (the following three operations) of analysis data (ANL-****.csv) is stopped.</p> <ul style="list-style-type: none"> • Stopping the sampling of the Time Series Database Function • Stopping the export of the Time Series Database Function • Stopping the transfer of CSV files from the AI Controller to the AI Operator <p>Click the Monitor/Operation - TSDB Function Buttons on the AI Operator to display the Monitor/Operation screen.</p>  <p>The screenshot shows the 'Monitor/Operation' interface with the following sections:</p> <ul style="list-style-type: none"> Data Collection Phase: 'Data Collection for Analysis' with a 'Suspend' button highlighted. Sampling Table: <table border="1"> <thead> <tr> <th>Monitor Item</th> <th>Status</th> <th>Operation</th> </tr> </thead> <tbody> <tr><td>1 RAW_DATA</td><td>Idle (a)</td><td>Start, Suspend, Clear</td></tr> <tr><td>2 ANL_DATA</td><td>Idle</td><td>Start, Suspend, Clear</td></tr> <tr><td>3 FTR_DATA</td><td>Idle</td><td>Start, Suspend, Clear</td></tr> <tr><td>4 AIS_DATA</td><td>Idle</td><td>Start, Suspend, Clear</td></tr> </tbody> </table> Export Table: <table border="1"> <thead> <tr> <th>Monitor Item</th> <th>Status</th> <th>Operation</th> </tr> </thead> <tbody> <tr><td>1 RAW_DATA</td><td>Idle (b)</td><td>Start, Suspend, Delete CSV</td></tr> <tr><td>2 ANL_DATA</td><td>Idle</td><td>Start, Suspend, Delete CSV</td></tr> <tr><td>3 FTR_DATA</td><td>Idle</td><td>Start, Suspend, Delete CSV</td></tr> <tr><td>4 AIS_DATA</td><td>Idle</td><td>Start, Suspend, Delete CSV</td></tr> </tbody> </table> CSV File Transfer Status Table: <table border="1"> <thead> <tr> <th>Monitor Item</th> <th>Status</th> <th>Operation</th> </tr> </thead> <tbody> <tr><td>1 RAW_DATA</td><td>Stopping (c)</td><td>Start, Suspend</td></tr> <tr><td>2 ANL_DATA</td><td>Stopping</td><td>Start, Suspend</td></tr> <tr><td>3 FTR_DATA</td><td>Stopping</td><td>Start, Suspend</td></tr> <tr><td>4 AIS_DATA</td><td>Stopping</td><td>Start, Suspend</td></tr> </tbody> </table> 	Monitor Item	Status	Operation	1 RAW_DATA	Idle (a)	Start, Suspend, Clear	2 ANL_DATA	Idle	Start, Suspend, Clear	3 FTR_DATA	Idle	Start, Suspend, Clear	4 AIS_DATA	Idle	Start, Suspend, Clear	Monitor Item	Status	Operation	1 RAW_DATA	Idle (b)	Start, Suspend, Delete CSV	2 ANL_DATA	Idle	Start, Suspend, Delete CSV	3 FTR_DATA	Idle	Start, Suspend, Delete CSV	4 AIS_DATA	Idle	Start, Suspend, Delete CSV	Monitor Item	Status	Operation	1 RAW_DATA	Stopping (c)	Start, Suspend	2 ANL_DATA	Stopping	Start, Suspend	3 FTR_DATA	Stopping	Start, Suspend	4 AIS_DATA	Stopping	Start, Suspend
Monitor Item	Status	Operation																																													
1 RAW_DATA	Idle (a)	Start, Suspend, Clear																																													
2 ANL_DATA	Idle	Start, Suspend, Clear																																													
3 FTR_DATA	Idle	Start, Suspend, Clear																																													
4 AIS_DATA	Idle	Start, Suspend, Clear																																													
Monitor Item	Status	Operation																																													
1 RAW_DATA	Idle (b)	Start, Suspend, Delete CSV																																													
2 ANL_DATA	Idle	Start, Suspend, Delete CSV																																													
3 FTR_DATA	Idle	Start, Suspend, Delete CSV																																													
4 AIS_DATA	Idle	Start, Suspend, Delete CSV																																													
Monitor Item	Status	Operation																																													
1 RAW_DATA	Stopping (c)	Start, Suspend																																													
2 ANL_DATA	Stopping	Start, Suspend																																													
3 FTR_DATA	Stopping	Start, Suspend																																													
4 AIS_DATA	Stopping	Start, Suspend																																													
Step 10-1 Stopping data collection		<p>Go to Data Collection Phase - Data Collection for Analysis and press the Suspend Button.</p> <p>This will stop the sampling/export of the Time Series Database Function and the transfer by the AI Operator.</p> <p>You can check that the collection has stopped by the following items:</p> <ol style="list-style-type: none"> Sampling status of the Time Series Database Function: Sampling of No.2 (ANL_DATA) Status is Idle Export status of the Time Series Database Function: Export of No.2 (ANL_DATA) Status is Idle Transfer status by the AI Operator: CSV File Transfer Status of No.2 (ANL_DATA) Status is Stopping <p>[Reference]</p> <p>You can also send a stop command from the user program.</p> <p>Execute the following instructions in the user program.</p> <p>Export: Execute the TimeSeries_ControlExport instruction with the following input variables.</p> <p>TimeSeries input variable: 'ANL_DATA' Cmd input variable: INT#2</p> <p>Sampling: Execute the TimeSeries_ControlSampling instruction with the following input variables.</p> <p>TimeSeries input variable: 'ANL_DATA' Cmd input variable: INT#2</p>																																													

6-4 Data Analysis Phase

The operations performed in the Data Analysis Phase are as follows.

Step		Operation of an engineer of OMRON
Step 11 Generating and downloading the AI machine learning model	Step 11-1 Generating and downloading the AI machine learning model	<p>This phase are performed by an engineer of OMRON.</p> <ul style="list-style-type: none"> • Generate the AI machine learning model from analysis data (ANL-****.csv). • Download the generated AI machine learning model to the AI Controller with the AI Operator.

6-5 Data Utilization Phase

The procedure to start the data utilization phase is as follows:

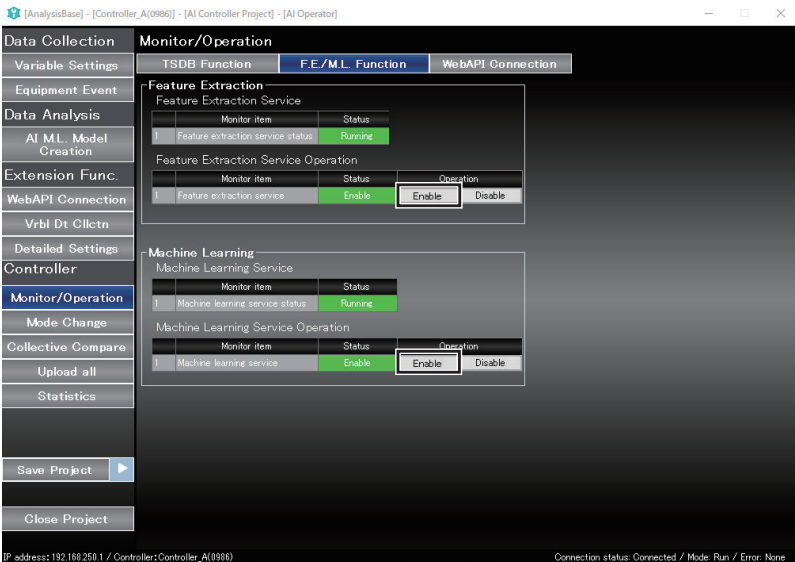
Step		User tasks
Step 12 Connecting the AI Controller with a computer	Step 12-1 Connecting the AI Controller with a computer	Use USBs or Ethernet cables to connect the AI Controller with the computer where Sysmac Studio is installed. (When you install the AI Operator to Windows for an NY-series AI Controllers, you are not required to use cable connections.)
Step 13 Creating programs	Step 13-1 Creating the Feature Value/Machine Learning Function program	<p>In the user program, send the run and idle commands for the Feature Extraction Function and the Machine Learning Function. Write a program as specified below on the Sysmac Studio and download the program to the AI Controller.</p> <ul style="list-style-type: none"> Send the run command to the Feature Extraction Function and to the Machine Learning Function when the equipment operation starts. Send the idle command to the Feature Extraction Function and to the Machine Learning Function when the equipment operation stops. <p>It will run the Feature Extraction Function and the Machine Learning Function when the equipment starts running in Step 16. It will also set the Feature Extraction Function and the Machine Learning Function to idle when the equipment stops running in Step 19.</p> <ul style="list-style-type: none"> Feature Extraction Function Assign TRUE (run) or FALSE (idle) to the Feature Extraction Service Enable Command (<code>_FE_Enable</code>) to send the command. Machine Learning Function Assign TRUE (run) or FALSE (idle) to the Machine Learning Service Enable Command (<code>_MLE_Enable</code>) to send the command. <p>[Reference] The run/idle commands for the Feature Extraction Function and the Machine Learning Function can be also sent from the AI Operator.</p> 

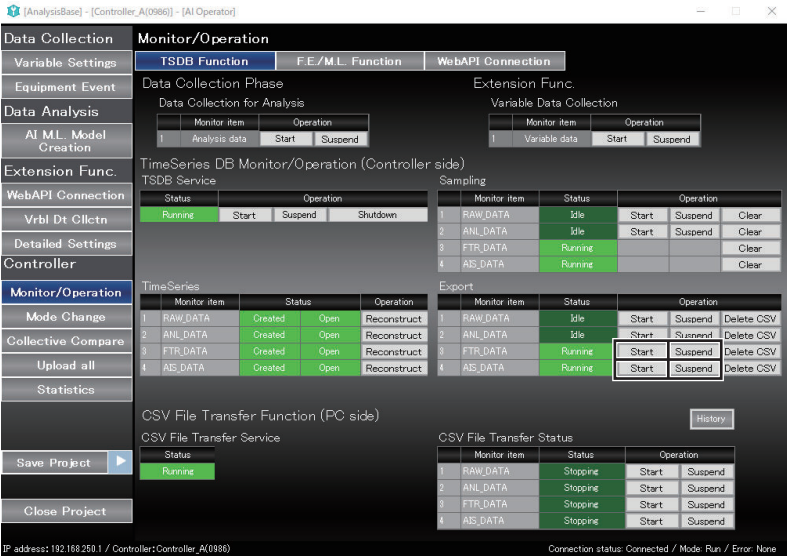
Step	Step	User tasks
	<p>Step 13-2 Creating the Time Series Database program</p>	<p>In the user program, send the commands for starting or stopping the export of the Time Series Database Function.</p> <p>Write a program as specified below on the Sysmac Studio and download the program to the AI Controller.</p> <ul style="list-style-type: none"> Send the command for starting the export of the Time Series Database Function when the equipment operation starts. Send the command for stopping the export of the Time Series Database Function when the equipment operation stops. <p>It will start the export when the equipment starts running in Step 16. It will also stop the export when the equipment stops running in Step 19.</p> <ul style="list-style-type: none"> Write a program for starting or stopping the export of feature data (FTR-****.csv) as specified below. TimeSeries_ControlExport instruction <ul style="list-style-type: none"> TimeSeries input variable: 'FTR_DATA' Cmd input variable: INT#1 (start command), INT#2 (stop command) Write a program for starting or stopping the export of equipment event monitoring score (AIS-****.csv) as specified below. TimeSeries_ControlExport instruction <ul style="list-style-type: none"> TimeSeries input variable: 'AIS_DATA' Cmd input variable: INT#1 (start command), INT#2 (stop command) <p>[Reference] The command to start or stop the export of feature value data and equipment event monitoring result data can be also sent from the AI Operator.</p>  <p>The screenshot shows the AI Operator interface with several panels: <ul style="list-style-type: none"> Variable Settings: Includes tabs for TSDB Function, F.E./M.L. Function, and WebAPI Connection. Data Collection Phase: Shows 'Data Collection for Analysis' and 'Variable Data Collection' with 'Start' and 'Suspend' buttons. TSDB Service: A table showing 'Status' as 'Running' and 'Operation' buttons for 'Start', 'Suspend', and 'Shutdown'. TimeSeries DB Monitor/Operation (Controller side): A table with columns for Monitor item, Status, and Operation. It lists RAW_DATA, ANL_DATA, FTR_DATA, and AIS_DATA. Sampling: A table with columns for Monitor item, Status, and Operation. It lists RAW_DATA, ANL_DATA, FTR_DATA, and AIS_DATA. Export: A table with columns for Monitor item, Status, and Operation. It lists RAW_DATA, ANL_DATA, FTR_DATA, and AIS_DATA. CSV File Transfer Function (PC side): Shows 'Status' as 'Running'. CSV File Transfer Status: A table with columns for Monitor item, Status, and Operation. It lists RAW_DATA, ANL_DATA, FTR_DATA, and AIS_DATA. </p>
<p>Step 14 Connecting the AI Controller with a computer</p>	<p>Step 14-1 Connecting the AI Controller with a computer</p>	<p>Use Ethernet cables to connect the AI Controller with the computer where the AI Operator is installed. (When you install the AI Operator to Windows for an NY-series AI Controllers, you are not required to use cable connections.) At this time, use the same domain for the computer's IP address and the AI Controller's IP address.</p>

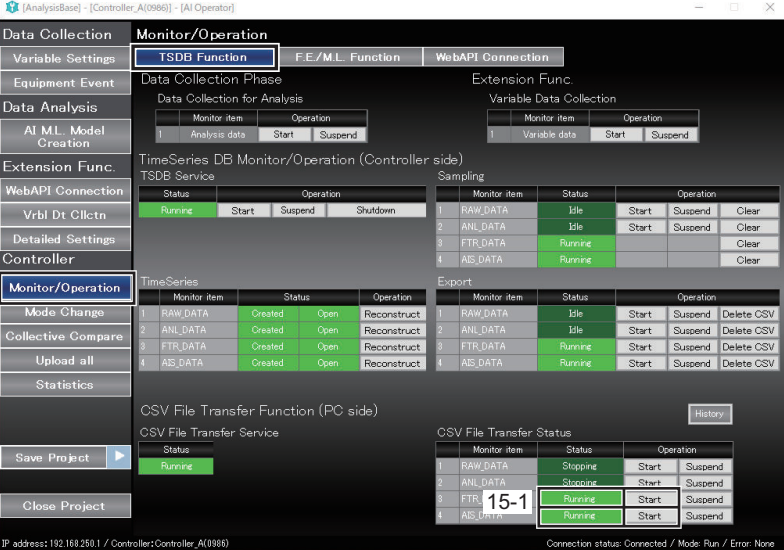
Step	User tasks	User tasks
<p>Step 15 Starting the transfer of CSV files from the AI Controller to the AI Operator</p>	<p>Open the Monitor/Operation screen and perform Step 15-1 through Step 15-2.</p>	<p>Start the transfer of feature value data and equipment event monitoring result data from the AI Controller to the AI Operator. Click the Monitor/Operation - TSDB Function Buttons on the AI Operator to display the Monitor/Operation screen.</p>  <p>The screenshot shows the 'Monitor/Operation' interface with several data tables. The 'TSDB Service' table shows 'RAW_DATA' as 'Running'. The 'TimeSeries DB Monitor/Operation (Controller side)' table shows 'RAW_DATA', 'ANL_DATA', 'FTR_DATA', and 'AIS_DATA' with various statuses like 'Idle', 'Running', 'Start', 'Suspend', and 'Clear'. The 'Export' table shows 'RAW_DATA', 'ANL_DATA', 'FTR_DATA', and 'AIS_DATA' with statuses 'Idle', 'Running', 'Start', and 'Suspend'. The 'CSV File Transfer Function (PC side)' table shows 'RAW_DATA', 'ANL_DATA', 'FTR_DATA', and 'AIS_DATA' with statuses 'Stopping', 'Running', 'Start', and 'Suspend'. A '15-1' label is visible over the FTR_DATA row in the CSV table.</p>
<p>Step 15-1 Starting the transfer of CSV files from the AI Controller to the AI Operator</p>	<p>Step 15-1 Starting the transfer of CSV files from the AI Controller to the AI Operator</p>	<ul style="list-style-type: none"> Go to CSV File Transfer Function (PC side) and press the Start Button for No.3 (FTR_DATA). Go to CSV File Transfer Function (PC side) and press the Start Button for No.4 (AIS_DATA). <p>When the data has been transferred successfully, Status of CSV File Transfer Status changes to Running.</p>
<p>Step 15-2 Starting the transfer of CSV files from the AI Controller to the Web server</p>	<p>Step 15-2 Starting the transfer of CSV files from the AI Controller to the Web server</p>	<p>Perform this step if you transfer the CSV file to a web server with the WebAPI Connection Function. For details on the procedure, refer to 6-6-1 <i>WebAPI Connection Function</i> on page 6-25.</p>
<p>Step 16 Starting device operation</p>	<p>Step 16-1 Starting device operation</p>	<p>Start the equipment operation.</p> <ul style="list-style-type: none"> The user program written in Step 13-1 executes and the Feature Value/ Machine Learning Function starts running. The user program written in Step 13-2 executes and the export of the Time Series Database Function starts.

Step	User tasks
<p>Step 17 Checking the AI function operation</p>	<p>Step 17-1 Checking that collection status is running</p> <p>On the AI Operator, select Monitor/Operation and press the TSDB Function Button to open the Monitor/Operation screen. Check the items (a) through (d) described below.</p> <ul style="list-style-type: none"> • Checking the operation status of the Time Series Database Function <ul style="list-style-type: none"> (a) Check to see if Status of TSDB Service in TimeSeries DB Monitor/Operation (Controller side) is Running. (b) Check to see if Status of Sampling in TimeSeries DB Monitor/Operation (Controller side) for No.3 (FTR_DATA) and No.4 (AIS_DATA) is Running. (c) Check to see if Status of Export in TimeSeries DB Monitor/Operation (Controller side) for No.3 (FTR_DATA) and No.4 (AIS_DATA) is Running. If the status is not running, check the user program created in Step 13. • Checking the transfer status from the AI Controller to the AI Operator <ul style="list-style-type: none"> (d) Check to see if Status of CSV File Transfer Status in CSV File Transfer Function (PC side) for No.3 (FTR_DATA) and No.4 (AIS_DATA) is Running.  <p>The screenshot shows the 'Monitor/Operation' screen with several tables and status indicators:</p> <ul style="list-style-type: none"> TSDB Service (Controller side): Status is 'Running' (a). Sampling (Controller side): FTR_DATA (No.3) and AIS_DATA (No.4) are 'Running' (b). Export (Controller side): FTR_DATA (No.3) and AIS_DATA (No.4) are 'Running' (c). CSV File Transfer Status (PC side): FTR_DATA (No.3) and AIS_DATA (No.4) are 'Running' (d).

Step	User tasks
<p>Step 17-2</p> <p>Checking that Feature Value/Machine Learning Function status is running</p>	<p>Check to see if the status of the Feature Value/Machine Learning Function is Running.</p> <p>On the AI Operator, select Monitor/Operation and press the F.E./M.L. Function Button to open the Monitor/Operation screen. Check the items (a) and (b) described below.</p> <p>a. Check to see if Status of Feature Extraction Service is Running. The Feature Extraction Function enters in the Running state when the Feature Extraction Service Enable Command (<code>_FE_Enable</code>) is TRUE and the AI Controller is in the RUN mode.</p> <p>b. Check to see if Status of Machine Learning Service is Running. The Machine Learning Function enters in the Running state when the Machine Learning Service Enable Command (<code>_MLE_Enable</code>) is TRUE and the AI Controller is in the RUN mode.</p> 
<p>Step 17-3</p> <p>Checking that frame variables/variable data/subframe variables are being written</p>	<p>Use the user program written in Step 3-1 to check if values are written to the following variables:</p> <ul style="list-style-type: none"> • Frame variables • Variable data • Subframe variables

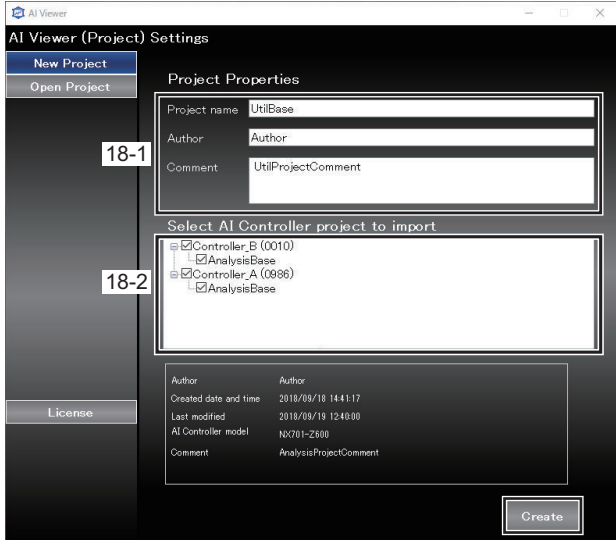
Step	User tasks
<p>Step 17-4 Checking collected data for missing or omitted data</p>	<ul style="list-style-type: none"> Check to see if the feature value data (FTR-****.csv) has been transferred to the following folder in the computer where the AI Operator is installed. <div style="border: 1px solid black; padding: 5px; margin: 5px 0;"> C:\OMRON\CSVData\[Controller_Serial_No.]\FTR_DATA\YYYY\MM\dd (YYYY indicates a year, MM indicates a month, and dd indicates a day.) </div> Check to see if the equipment event monitoring result data (AIS-****.csv) has been transferred to the following folder in the computer where the AI Operator is installed. <div style="border: 1px solid black; padding: 5px; margin: 5px 0;"> C:\OMRON\CSVData\[Controller_Serial_No.]\AIS_DATA\YYYY\MM\dd (YYYY indicates a year, MM indicates a month, and dd indicates a day.) </div> <p>Open the CSV file and check the indx (index) field values to see if there is no irregular increment.</p> <p>If there is any missing indx (index) field value, take any of the following measures.</p> <ul style="list-style-type: none"> Reduce the volume of variables (size and number of variables) to collect. Increase the task period of the primary periodic task. Increase the export period. Secure the execution time for the system services. <p>* For details on the CSV file format, refer to <i>A-5 CSV File Format</i> on page A-32.</p>
<p>Step 18 Visualizing with the AI Viewer</p>	<p>The AI Viewer allows you to visualize feature value data and equipment event monitoring result data that the AI Operator collected from the AI Controller. Start the AI Viewer.</p> 
<p>Step 18-1 Setting project names</p>	<p>Set up a project on the AI Viewer. These settings can be left as default.</p> <ul style="list-style-type: none"> Specify Project name. Specify Author. Enter Comment.

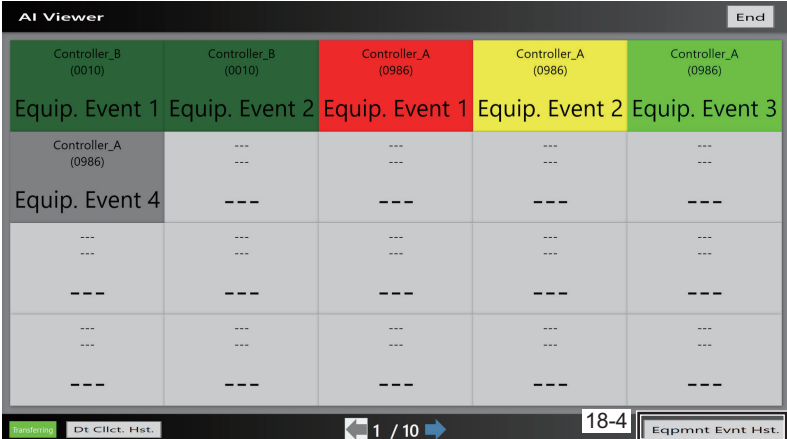
Step	User tasks
<p>Step 18-2 Importing the AI Controller project to monitor equipment events</p>	<p>Import an AI Controller project that is output by the AI Operator to the AI Viewer. In the field of Select AI Controller project to import, projects grouped by each AI Controller are displayed in a tree view. The numbers shown here are the serial number of AI Controller.</p> <p>If an AI Controller has more than one AI Controller project, the projects are displayed by pressing the + Button.</p> <ul style="list-style-type: none"> • Select a check box for the AI Controller you will monitor. • Press the + Button for the AI Controller you will monitor and select a check box for the AI Controller project. <p>*Select one AI Controller project for an AI Controller.</p> <ul style="list-style-type: none"> • Press the Create Button.
<p>Step 18-3 Displaying the Status Monitoring screen</p>	<p>When you press the Event Monitoring Button, the status monitoring screen for the AI Controller project selected in Step 18-2 is displayed. The top part of each equipment event button indicates the controller name of the AI Controller. The bottom part indicates equipment event name.</p> <p>The meaning of each button color is explained as follows:</p> <ul style="list-style-type: none"> • Dark green ■: Stopped Data transfer from the AI Controller to the AI Viewer is not in progress • Light green ■: Normal Data transfer from the AI Controller to the AI Viewer is in progress and the equipment event monitoring score is less than Threshold 1 • Yellow ■: Alarm Level 1 Data transfer from the AI Controller to the AI Viewer is in progress and the equipment event monitoring score is equal to or greater than Threshold 1 but less than Threshold 2 • Red ■: Alarm Level 2 Data transfer from the AI Controller to the AI Viewer is in progress and the equipment event monitoring score is equal to or greater than Threshold 2 • Gray ■: Error Data transfer from the AI Controller to the AI Viewer is in progress and the equipment event monitoring score is negative infinity <p>The AI Operator transfers equipment event monitoring result files (CSV files) from the AI Controller, and the result is displayed.</p> 

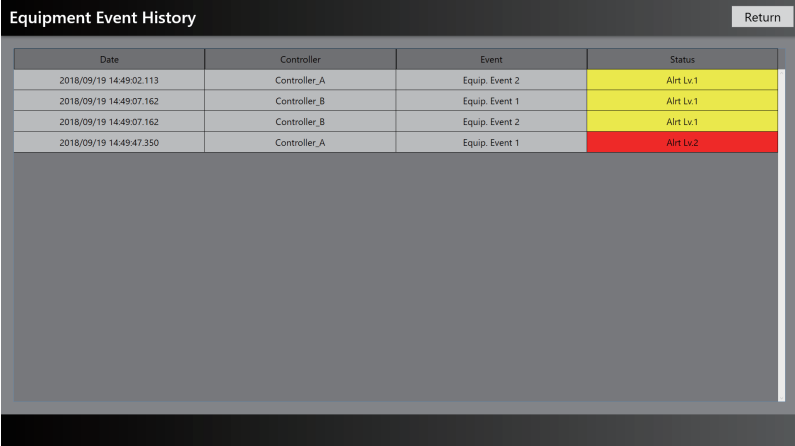
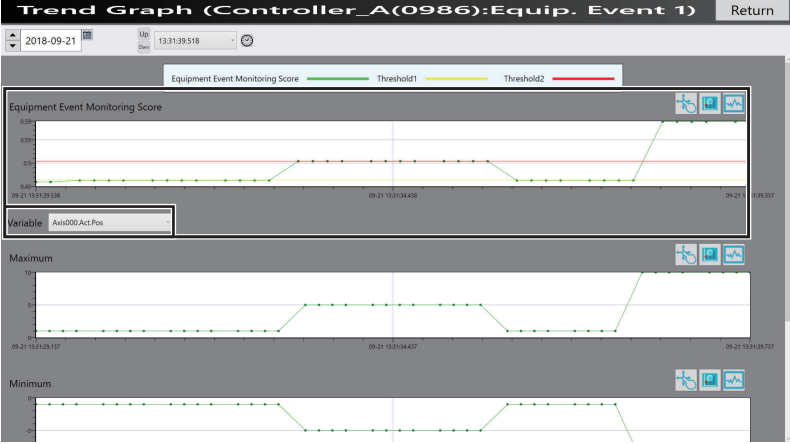
Step	User tasks	User tasks																				
<p>Step 18-4 Displaying equipment event history</p>		<p>On the Status Monitoring screen described in Step 18-3, press the Eqmnt Evnt Hst. Button. The Equipment Event History window opens. The transition among Alarm Level 1 / Alarm Level 2 can be checked as logs. The logs you can check here are those displayed after showing the Status Monitoring screen described in Step 18-3.</p>  <table border="1" data-bbox="576 504 1358 611"> <thead> <tr> <th>Date</th> <th>Controller</th> <th>Event</th> <th>Status</th> </tr> </thead> <tbody> <tr> <td>2018/09/19 14:49:02.113</td> <td>Controller_A</td> <td>Equip. Event 2</td> <td>Alert Lv.1</td> </tr> <tr> <td>2018/09/19 14:49:07.162</td> <td>Controller_B</td> <td>Equip. Event 1</td> <td>Alert Lv.1</td> </tr> <tr> <td>2018/09/19 14:49:07.162</td> <td>Controller_B</td> <td>Equip. Event 2</td> <td>Alert Lv.1</td> </tr> <tr> <td>2018/09/19 14:49:47.350</td> <td>Controller_A</td> <td>Equip. Event 1</td> <td>Alert Lv.2</td> </tr> </tbody> </table>	Date	Controller	Event	Status	2018/09/19 14:49:02.113	Controller_A	Equip. Event 2	Alert Lv.1	2018/09/19 14:49:07.162	Controller_B	Equip. Event 1	Alert Lv.1	2018/09/19 14:49:07.162	Controller_B	Equip. Event 2	Alert Lv.1	2018/09/19 14:49:47.350	Controller_A	Equip. Event 1	Alert Lv.2
Date	Controller	Event	Status																			
2018/09/19 14:49:02.113	Controller_A	Equip. Event 2	Alert Lv.1																			
2018/09/19 14:49:07.162	Controller_B	Equip. Event 1	Alert Lv.1																			
2018/09/19 14:49:07.162	Controller_B	Equip. Event 2	Alert Lv.1																			
2018/09/19 14:49:47.350	Controller_A	Equip. Event 1	Alert Lv.2																			
<p>Step 18-5 Displaying the Trend Graph</p>		<p>On the Status Monitoring screen described in Step 18-3, press any of the equipment event buttons. The Trend Graph screen opens. It displays a transition of the equipment event monitoring score and the feature value that is adopted in the AI machine learning model.</p> 																				
<p>Step 19 Stopping device operation</p>	<p>Step 19-1 Stopping device operation</p>	<p>Stop the equipment operation.</p> <ul style="list-style-type: none"> • The user program written in Step 13-1 executes and the Feature Value/ Machine Learning Function becomes idle. • The user program written in Step 13-2 executes and the export of the Time Series Database Function stops. 																				

Step	User tasks	
<p>Step 20 Stopping the transfer of CSV files from the AI Controller to the AI Operator</p>	<p>Open the Monitor/Operation screen and perform Step 20-1 through Step 20-2.</p>	<p>Stop the transfer of feature value data and equipment event monitoring result data from the AI Controller to the AI Operator. Click the Monitor/Operation - TSDB Function Buttons to display the Monitor/Operation screen.</p>  <p>The screenshot shows the 'Monitor/Operation' interface with several sections: 'Data Collection' (TSDB Function, F.E./M.L. Function, WebAPI Connection), 'Data Analysis' (Data Collection Phase, Variable Data Collection), 'TimeSeries DB Monitor/Operation (Controller side)' (TSDB Service, Sampling), 'TimeSeries' (table with columns: Monitor item, Status, Operation), 'Export' (table with columns: Monitor item, Status, Operation), 'CSV File Transfer Function (PC side)' (CSV File Transfer Service), and 'CSV File Transfer Status' (table with columns: Monitor item, Status, Operation). A red box highlights the '20-1' in the CSV File Transfer Status table for item 4 (AIS_DATA).</p>
<p>Step 20-1 Stopping the transfer of CSV files from the AI Controller to the AI Operator</p>		<ul style="list-style-type: none"> Go to CSV File Transfer Function (PC side) and press the Suspend Button for No.3 (FTR_DAT). Go to CSV File Transfer Function (PC side) and press the Suspend Button for No.4 (AIS_DATA). <p>When the data has been transferred successfully, Status of CSV File Transfer Function (PC side) changes to Stopping.</p>
<p>Step 20-2 Stopping the transfer of CSV files from the AI Controller to Web server</p>		<p>Perform this step if you transfer the CSV file to a web server with the WebAPI Connection Function. For details on the procedure, refer to <i>6-6-1 WebAPI Connection Function</i> on page 6-25.</p>

Step	User tasks
<p>Step 21 Powering off the AI Controller</p>	<p>Step 21-1 Shutting down the TSDB Service</p> <p>Shut down the TSDB service. Click the Monitor/Operation - TSDB Function Buttons to display the Monitor/Operation screen. Go to TimeSeries DB Monitor/Operation (Controller side) and press Shutdown. When the service has shutdown successfully, Status of TSDB Service changes to Terminated.</p>  <p>Step 21-2 Powering off the AI Controller</p> <p>Turn OFF the power supply to the AI Controller.</p>



Precautions for Safe Use

Check the created parameters for proper execution and then use them for actual operation.

6-6 Using Extension Function

As an extension function, the AI Operator allows you to configure the WebAPI Connection Function. The WebAPI Connection Function allows you to transfer the various AI Controller data to a Web server.

6-6-1 WebAPI Connection Function

When you transfer CSV files to Web servers with the WebAPI Connection Function, configure settings according to the procedure described below.

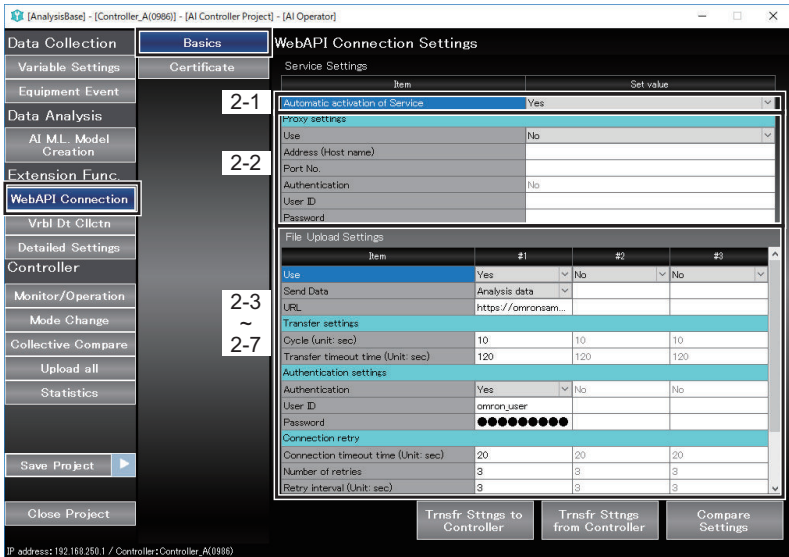
Step	User tasks
WebAPI Step 1 Building Network Environment	Connect the AI Controller and Web server to the network environment. Also, when you upload files via HTTPS communication, obtain a root certificate. (In case of HTTPS communication, you need to import the certificate to the AI Controller.)
WebAPI Step 2 Configuring the WebAPI Connection Function	<p>Press WebAPI Connection - Basics Button to display the WebAPI Connection Settings screen.</p> 
WebAPI Step 2-1 Starting the WebAPI service	<p>Select Yes for Automatic activation of the service. This will change the WebAPI connection service to Running upon the AI Controller startup. (However, if an error is detected, the status will change to Error.)</p>

Step	User tasks
WebAPI Step 2-2 Proxy settings	Set proxy settings as follows. When proxy is not used: <ul style="list-style-type: none"> • Select No for Use. • Proceed to WebAPI Step 2-3. When proxy is used: <ul style="list-style-type: none"> • Select Yes for Use. • Set the IP address or host name of the proxy server to Address (Host name). • Set the port number of the proxy server to Port No. • Set basic authentication settings for connecting to proxy server as follows. <ol style="list-style-type: none"> a. When the basic authentication is not performed <ul style="list-style-type: none"> • Select No for Authentication. b. When the basic authentication is performed <ul style="list-style-type: none"> • Select Yes for Authentication. • Set User ID. • Set Password.
WebAPI Step 2-3 Setting Web server address	<ul style="list-style-type: none"> • To upload files, select Yes for Use. • Select data to transfer on Send Data. (Analysis data, Feature value, or Equipment Event Monitoring Score.) • Set the Web server address to URL.
WebAPI Step 2-4 Transfer settings	These settings can be left as default. Refer to <i>Section 4 WebAPI Connection Function</i> on page 4-1 for details on the settings.
WebAPI Step 2-5 Authentication settings	Set basic authentication settings for connecting to the Web server as follows. When the basic authentication is not performed: <ul style="list-style-type: none"> • Select No for Authentication. When the basic authentication is performed: <ul style="list-style-type: none"> • Select Yes for Authentication. • Set User ID. • Set Password.
WebAPI Step 2-6 Connection retry	These settings can be left as default. Refer to <i>Section 4 WebAPI Connection Function</i> on page 4-1 for details on the setting items.
WebAPI Step 2-7 Security settings	These settings can be left as default. Refer to <i>Section 4 WebAPI Connection Function</i> on page 4-1 for details on the setting items.

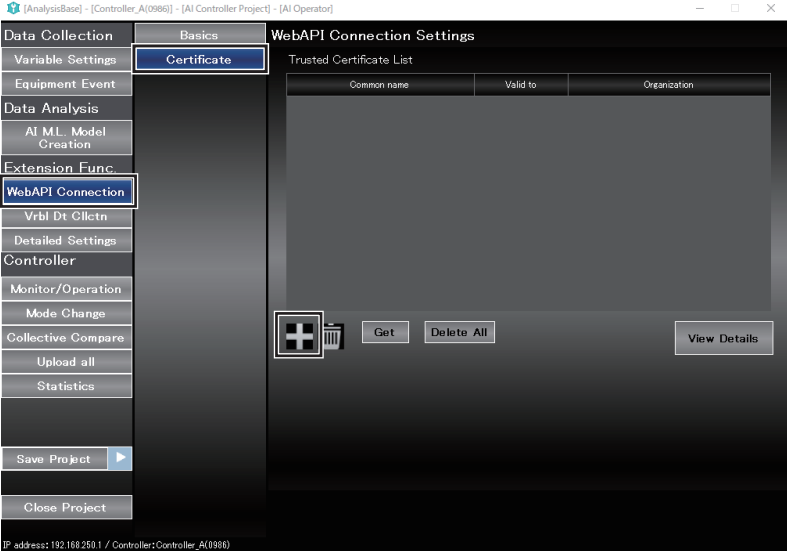
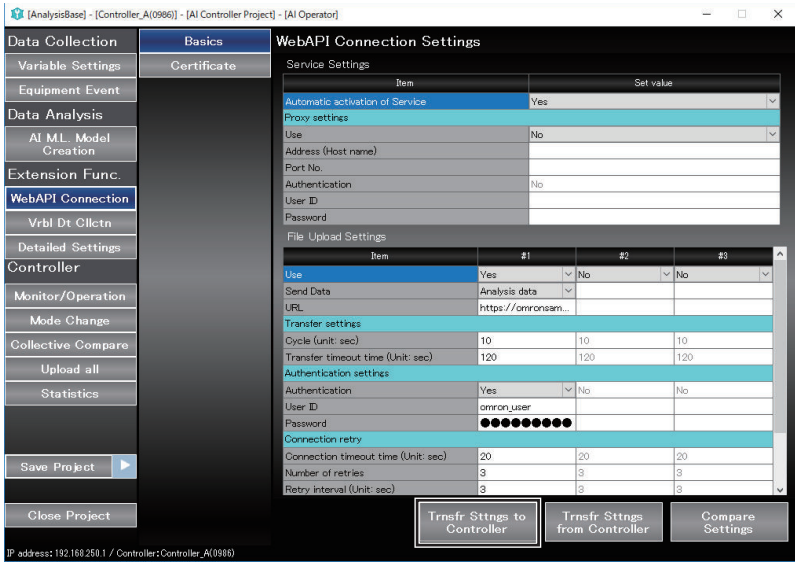
Step	User tasks	
<p>WebAPI Step 3 Importing Certificate</p>	<p>WebAPI Step 3-1 Importing certificate</p>	<p>When you use <i>HTTPS</i> to communicate with the WebAPI server, you need to import a root certificate to the AI Controller.</p> <p>This setting is required only when the destination URL that is set in WebAPI Step 2-3 is an <i>HTTPS</i> address.</p> <p>When communicating with Web server via <i>HTTP</i>:</p> <ul style="list-style-type: none"> Go to WebAPI Step 4. <p>When communicating with Web server via <i>HTTPS</i>:</p> <ul style="list-style-type: none"> Press WebAPI Connection - Certificate Button to display the WebAPI Connection Settings screen. Press the + Button. A dialog for file selection will be displayed. Select the root certificate to import. If you import more than one root certificate, repeat WebAPI Step 3-1. 
<p>WebAPI Step 4 Downloading WebAPI Connection Function Settings</p>	<p>WebAPI Step 4-1 Downloading WebAPI Connection Function settings</p>	<p>Press the Trnsfr Sttgs to Controller Button.</p> 

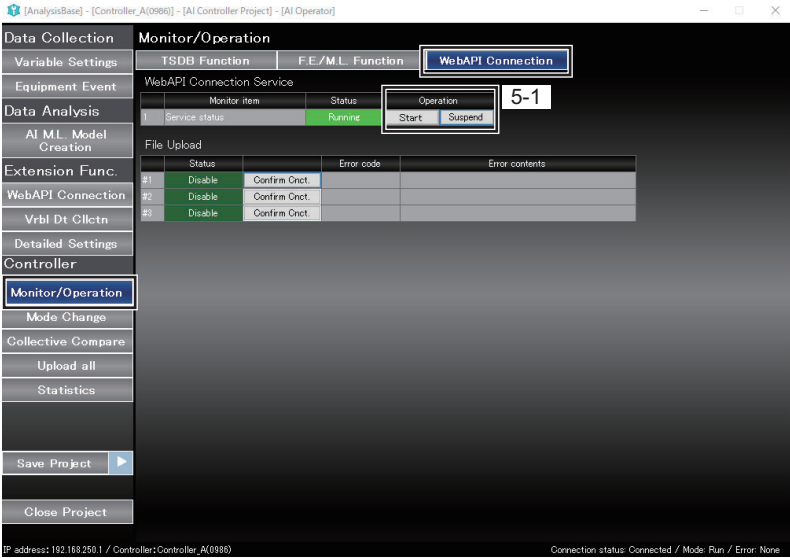
Step		User tasks
WebAPI Step 5 Starting/Stopping File Upload	WebAPI Step 5-1 Starting/stopping file upload	<p>Click Monitor/Operation - WebAPI Connection on the AI Operator to display the Monitor/Operation screen.</p>  <p>To start the WebAPI connection service, press Start Button. To stop the WebAPI connection service, press Suspend Button.</p>

6-6-2 Variable Data Collection

This function collects variable data for an equipment (except for frame variables and subframe variables).

You can use it if you want to determine variable data after you check the values of the variables in *6-2 Preliminary Preparation Phase* on page 6-6.

Use the following procedure to collect variable data.

Step		User tasks
RAW Step 1 Preparing the AI Controller	RAW Step 1-1 Preparing the AI Controller	Perform the same procedure described in Step 2 in <i>6-2 Preliminary Preparation Phase</i> on page 6-6.
RAW Step 2 Downloading User Program and FTP Server Function Settings From the Sys-mac Studio	---	Set only Variable data with the same procedure described in Step 3 in <i>6-2 Preliminary Preparation Phase</i> on page 6-6. You do not need to input Frame variables , Sub-frame Variable , F.E. Output Frame Var. , and M.L. Output Frame Var. .
RAW Step 3 Connecting the AI Controller to a Computer	---	Perform the same procedure described in Step 4 in <i>6-3 Data Collection Phase</i> on page 6-8.
RAW Step 4 Common Settings in the AI Operator	---	Perform the same procedure described in Step 5 in <i>6-3 Data Collection Phase</i> on page 6-8.

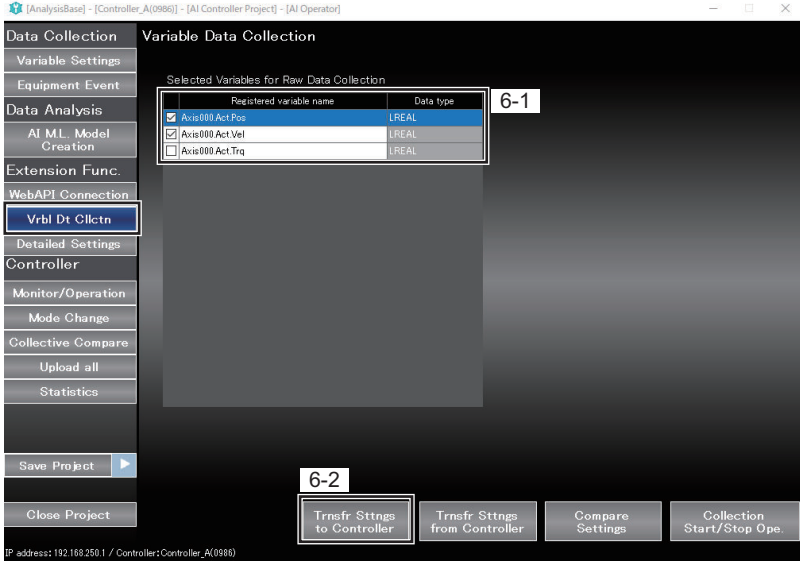
Step	User tasks
RAW Step 5 Setting Variable Data	---
RAW Step 6 Downloading Variable Data	<p>Switch to the Variable Data Collection screen and perform RAW Step 6-1 and 6-2.</p> 
RAW Step 6-1 Setting variable data	<p>The variable data that you set in RAW Step 5 is displayed in Registered variable name. Select the check box for each variable that you want to collect.</p>
RAW Step 6-2 Downloading the settings	<p>Press the Trnsfr Sttns to Controller Button.</p>

Step	User tasks
<p>RAW Step 7 Starting Data Collection</p>	<p>In this step, the collection (the following three operations) of variable data (RAW-****.csv) is started.</p> <ul style="list-style-type: none"> Starting the sampling of Time Series Database Function Starting the export of Time Series Database Function Starting the transfer of CSV files from the AI Controller to the AI Operator <p>Click the Monitor/Operation - TSDB Function Buttons on the AI Operator to display the Monitor/Operation screen.</p> 
<p>RAW Step 7-1 Starting data collec- tion</p>	<p>Select Extension Func. - Vrbl Dt Clctn and press the Start Button.</p> <p>You can check that the collection has started by the following items:</p> <ol style="list-style-type: none"> Sampling status of the Time Series Database Function: Sampling of No.1 (RAW_DATA) Status is Running Export status of the Time Series Database Function: Export of No.1 (RAW_DATA) Status is Running Transfer status by the AI Operator: CSV File Transfer Status of No.1 (RAW_DATA) Status is Running <p>The variable data file (RAW-****.csv) is transferred to the following folder in the computer where the AI Operator is installed.</p> <p>* For details on the CSV file format, refer to <i>A-5 CSV File Format</i> on page A-32.</p> <div style="border: 1px solid black; padding: 5px; margin-top: 10px;"> <p>C:\OMRON\CSVData\[Controller_Serial_No.]\RAW_DATA\YYYY\MM\dd\ (YYYY: Year/MM: Month/dd: Day)</p> </div>

Step	User tasks
<p>RAW Step 8 Stopping Data Collection</p>	<p>In this step, the collection (the following three operations) of analysis data (RAW-****.csv) is stopped.</p> <ul style="list-style-type: none"> Starting the sampling of Time Series Database Function Starting the export of Time Series Database Function Stopping the transfer of CSV files from the AI Controller to the AI Operator <p>Click the Monitor/Operation - TSDB Function Buttons on the AI Operator to display the Monitor/Operation screen.</p>  <p>The screenshot shows the 'Monitor/Operation' interface with several tables and controls. A red box labeled '8-1' highlights the 'Variable Data Collection' table. A red box labeled '(a)' highlights the 'Sampling' table. A red box labeled '(b)' highlights the 'Export' table. A red box labeled '(c)' highlights the 'CSV File Transfer Status' table. The 'TSDB Service' status is 'Running'. The 'CSV File Transfer Service' status is 'Running'.</p>
<p>RAW Step 8-1 Stopping data collection</p>	<p>Select Extension Func. - Vrbl Dt Clctn and press the Stop button.</p> <p>You can check that the collection has stopped by the following items:</p> <ol style="list-style-type: none"> Sampling status of the Time Series Database Function: Sampling of No.1 (RAW_DATA) Status is Stopping Export status of the Time Series Database Function: Export of No.1 (RAW_DATA) Status is Stopping Transfer status by the AI Operator: CSV File Transfer Status of No.1 (RAW_DATA) Status is Stopping



Maintenance

This section describes the backup functions and the storage replacement on the AI Controller.

7-1	Introduction	7-2
7-2	Data That Is Backed Up and Compatibility Between the Models	7-3
7-2-1	Backup Data (NX701-Z□00 and NY5□2-Z□00)	7-3
7-2-2	Compatibility between the Models (NX701-Z□00 and NY5□2-Z□00)	7-4
7-2-3	Compatibility between the Unit Versions (NX701-Z□00 and NY5□2-Z□00).....	7-4
7-3	Storage Replacement	7-5
7-3-1	Storage Replacement Timing	7-5
7-3-2	Data Saved in the Storage.....	7-5
7-3-3	Replacement Procedure	7-6
7-3-4	Checking Operation After Replacement (NX701-Z□00, NY5□2-Z□00)	7-8

7-1 Introduction

To properly maintain and inspect AI Controllers, take note of data to be backed up, compatibility between models, and storage replacement. This section describes the functional specifications related to these procedures. The term storage in this section refers to non-volatile memory media used with Time Series Database Function on the AI Controller. This would be the SD Memory Card in NX-series AI Controller, and expanded storage in drive bay A in NY-series AI Controller.

For other periodic maintenance and inspection procedures, refer to the following manuals.

- NX-series AI Controller (NX701-Z□□□):
NX-series CPU Unit Hardware User's Manual (Cat. No. W535)
- NY-series AI Controller (NY5□2-Z□□□):
NY-series Industrial Box PC Hardware User's Manual (Cat. No. W556)
NY-series Industrial Panel PC Hardware User's Manual (Cat. No. W557)
NY-series Industrial Panel PC and Industrial Box PC Setup User's Manual (Cat. No. W568)

The following specifies the overview of "Data that is backed up and compatibility between the models" and "Storage replacement".

Item	Overview	Reference
Data that is backed up and Compatibility between the Models	Describes data for the backup function of the AI Controller along with the compatibility between Controller models and between Unit versions.	<i>7-2 Data That Is Backed Up and Compatibility Between the Models on page 7-3</i>
Storage Replacement	Describes when to replace the storage of the AI Controller target media, saved data as well as the replacement procedure.	<i>7-3 Storage Replacement on page 7-5</i>

7-2 Data That Is Backed Up and Compatibility Between the Models

This section describes the data for backup function of the AI Controller and explains the compatibility between Controller models and between Unit versions depending on the model number.



Additional Information

If you perform backup and restore operations with an NY-series AI Controller using the Industrial PC Support Utility, make sure to use the Industrial PC Support Utility version 1.1.1541 or higher.

7-2-1 Backup Data (NX701-Z□00 and NY5□2-Z□00)

The backup function performs to the setting information of the AI Controller functions that are specified on the AI Operator, the AI machine learning models, and the event logs.*1 All the data that is backed up are treated as items of *User program and settings* in the *data group*.

For details on the data that is backed up for the common Controllers, refer to the *Data That Is Backed Up* in the *NJ/NX-series CPU Unit Software User's Manual (Cat. No. W501)* or the *NY-series Industrial Panel PC / Industrial Box PC Software User's Manual (Cat. No. W558)*.

*1. This does not apply to *Importing and exporting Sysmac Studio backup file*.

(OK: Applicable, NA: Not applicable)

AI Controller function	Data targeted for operation	Backup	Restore and verification
Time Series Database Function	Settings for the Time Series Database Function	OK	OK
	Data in TimeSeries	NA	NA
	Exported CSV file	NA	NA
	Event logs*1	OK	NA
Feature Value/Machine Learning Function	Settings for the Feature Value/Machine Learning Function	OK	OK
	AI machine learning model	OK*2	OK*2
	Event logs*1	OK	NA
WebAPI Connection Function	Settings for WebAPI Connection Function	OK	OK
	CA certificates	OK	OK
	Event logs*1	OK	NA

*1. Event logs are targeted for backup since they store data associated with the backup source device. However, they are not targeted for restore.

*2. The automatic transfer from SD Memory Card function and program transfer from SD Memory Card function are not targeted for backup, restore, and verification.

7-2-2 Compatibility between the Models (NX701-Z□00 and NY5□2-Z□00)

This section describes the compatibility of backup data between the NX-series and NY-series Controllers.

The following table specifies the backup function compatibility between the backup source and the restore destination when the AI Controller models are different.

(C: Compatible, N: Not compatible)

AI Controller model where data was backed up	AI Controller model to restore to	
	NX701-Z700 NX701-Z600	NY5□2-Z500 NY5□2-Z400 NY5□2-Z300
NX701-Z700 NX701-Z600	C	N
NY5□2-Z500 NY5□2-Z400 NY5□2-Z300	N	C



Additional Information

There is no compatibility for the backup data between the AI Controllers and the Automation Controllers that are not the AI Controllers.

7-2-3 Compatibility between the Unit Versions (NX701-Z□00 and NY5□2-Z□00)

The compatibility of the AI Controller's backup data between the Unit versions are same as that for the standard controllers.

Refer to the *Compatibility between Unit Versions of CPU Units* in the *NJ/NX-series CPU Unit Software User's Manual (Cat. No. W501)* or *Compatibility between Unit Versions of NY-series Controllers* in the *NY-series Industrial Panel PC / Industrial Box PC Software User's Manual (Cat. No. W558)*.

7-3 Storage Replacement

This section describes when to replace the AI Controller's storage, target media format, saved data, as well as the replacement procedure for each model.

For formats and specifications of storage subject to replacement, refer to *General Specifications* on page A-5.



Precautions for Correct Use

- If you replace the storage in the procedure described in this manual, you cannot migrate data saved in the old storage.
- If you insert a new storage into a wrong drive bay, the AI Controller may not start up. Make sure to insert an expanded storage into drive bay A.
- Do not replace the main storage inserted into the AI Controller to another main storage in a different format. If you do so, it could prevent the AI Controller from starting up.

7-3-1 Storage Replacement Timing

NX701-Z□00

NX-series AI Controllers allow you to check the replacement timing with SD Memory Card life expiration detection. For details on how to use this function, refer to *SD Memory Card Life Expiration Detection* in the *NX-series CPU Unit Software User's Manual (Cat. No. W501)*.

If you use an OMRON SD Memory Card, the end of the life of the SD Memory Card can be detected in the following methods.

When the end of the life is detected, replace the SD Memory Card.

- `_Card1Deteriorated` (SD Memory Card Life Warning Flag) system-defined variable
- SD Memory Card Life Exceeded* event

NY5□2-Z□00

NY-series AI Controllers allow you to detect the end of service life for the expanded storage (SSD) that is inserted to drive bay A and check the replacement timing of the storage.

The detection for the end of service life of the expanded storage is performed in the *Expanded Storage Life* event. Replace the expanded storage when you see this event.

7-3-2 Data Saved in the Storage

Data in the TimeSeries is saved in the storage you use for the Time Series Database Function of the AI Controller. Note that you cannot migrate the data when you replace the storage.

7-3-3 Replacement Procedure

NX701-Z□00

Replace the SD Memory Card for the NX-series Controller.

Refer to *Installing and Removing the SD Memory Card* in the *NX-series CPU Unit Hardware User's Manual (Cat. No. W535)* to remove the old SD Memory Card and replace it with a new one.

NY5□2-Z□00

This section describes the replacement procedure of the expanded storage (SSD) in the drive bay A of the NY-series Controller. After you replace the SSD on the NY-series AI Controller, you need to format the new SSD. Use the Rescue Disk Utility to format the SSD.

The Rescue Disk Creator to install the Rescue Disk Utility is installed in Windows of the AI Controller.

Step	Item	Description
Step 1	Verification and preparation to the replacement	<p>Make sure that you prepare a USB storage device to install the Rescue Disk Utility. Next, refer to <i>Backing up and Recovering the Industrial PC System</i> in the <i>NY-series Industrial Panel PC / Industrial Box PC Setup User's Manual (Cat. No. W568)</i>, and install the Rescue Disk Utility into the USB storage device.</p> <p>At this time, check to see if the version of Rescue Disk Creator that you will use to install the Rescue Disk Utility is version 1.1.2004.010000040 or higher. You can check the version of Rescue Disk Creator by opening Control Panel and selecting Programs and Features. If the installed version is older than this version, download the latest version of Rescue Disk Creator from the OMRON website and install it to your NY-series AI Controller.</p>
Step 2	SSD replacement	<p>Refer to <i>Drive Replacement</i> in the <i>NY-series Industrial Box PC Hardware User's Manual (Cat. No. W556)</i> or the <i>NY-series Industrial Panel PC Hardware User's Manual (Cat. No. W557)</i> and replace the expanded storage (SSD) in Drive Bay A.</p>

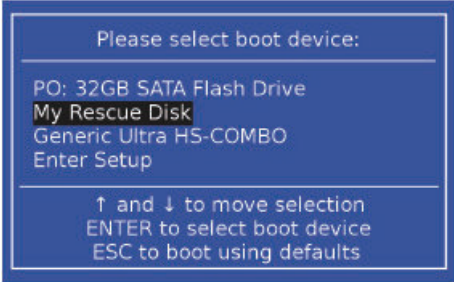
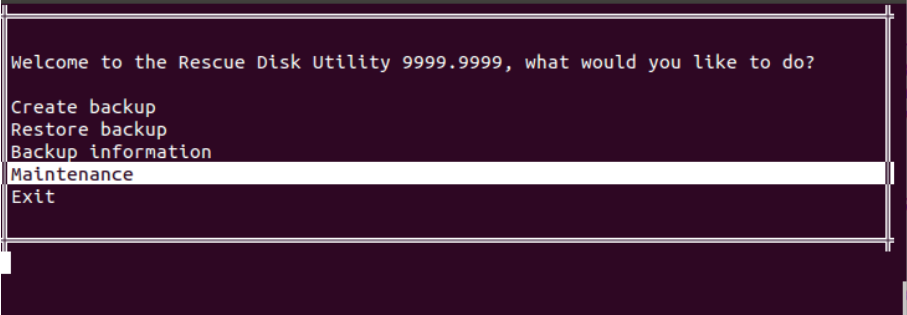
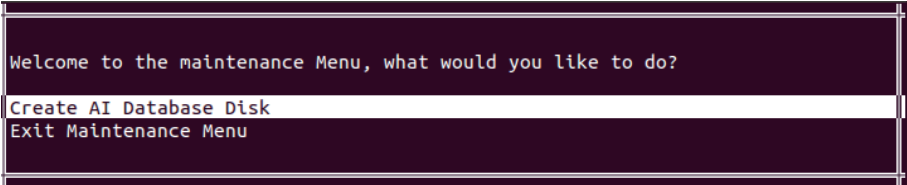
Step	Item	Description
Step 3	SSD formatting	<p><u>Step3-1</u> While the power of the NY-series AI Controller turned off, mount the USB storage device where the Rescue Disk Utility is installed to the NY-series AI Controller.</p> <p><u>Step3-2</u> Press the power button of the NY-series AI Controller and press the F11 Key on the keyboard. The screen where you select a device to start will appear.</p>  <p>The name of the USB storage device displayed on the screen varies for each USB storage device. The <i>My Rescue Disk</i> is shown as an example here.</p> <p><u>Step3-3</u> Select a USB storage device where the Rescue Disk Utility is installed and press the Enter Key. The Rescue Disk Utility starts and the Main Menu appears.</p>  <p>*9999.9999 shows the version number of Rescue Disk Utility.</p> <p><u>Step3-4</u> Select Maintenance and press the Enter Key. The Maintenance Menu screen appears.</p> 

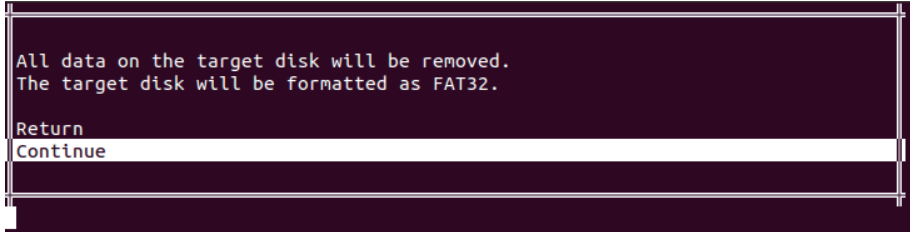
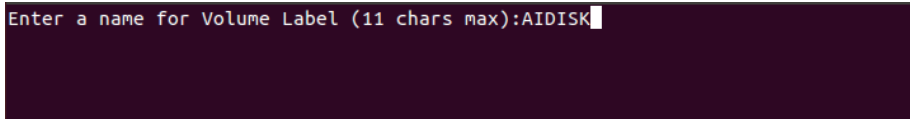
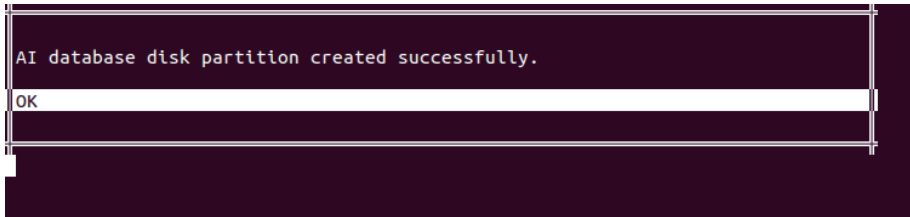
Step	Item	Description
		<p><u>Step3-5</u> Select Create AI Database Disk and press the Enter Key. A confirmation screen to continue the formatting appears.</p>  <p><u>Step3-6</u> Select Continue and press the Enter Key. The screen where you input the volume label for the SSD to format appears.</p>  <p><u>Step3-7</u> Enter a volume label and press the Enter Key to start the SSD formatting. * Up to 11 characters can be entered for the volume label. * The volume label entry is optional. Once the formatting finishes successfully, the completion screen appears.</p>  <p><u>Step3-8</u> After OK is selected, press the Enter Key to go back to the Main Menu. When you select Exit and press the Enter Key on the Main Menu, the power of the NY-series AI Controller automatically turns off.</p>
Step 4	Re-start after the replacement	<p>Make sure that the power is not turned on when you remove the USB storage device. Press the power button and start the NY-series AI Controller.</p>

7-3-4 Checking Operation After Replacement (NX701-Z□00, NY5□2-Z□00)

In the **Tools - Troubleshooting** Dialog Box on the Sysmac Studio, select **Controller error** Tab Page and check that there is not an error related to the storage. If an error has occurred, refer to *Section 8 Troubleshooting* on page 8-1 and take suitable measures for the relevant event.

8

Troubleshooting

This section describes the errors (events) that can occur in the AI Controller uniquely. The corrections for them are also given.

The troubleshooting methods and event codes other than the AI Controller are used in the same series. For the NX-series, refer to the *NJ/NX-series Troubleshooting Manual (Cat. No. W503)*. For the NY-series, refer to the *NY-series Troubleshooting Manual (Cat. No. W564)*.

8-1	Overview of Errors	8-2
8-1-1	How to Check for Errors	8-2
8-1-2	Errors Related to the AI Functions.....	8-4
8-2	Troubleshooting	8-7
8-2-1	Error Table	8-7
8-2-2	Error Description	8-15

8-1 Overview of Errors

You manage all of the errors that occur on the AI Controller as events. The same methods are used for all events. This allows you to see what errors have occurred and find corrections for them with the same methods for the entire range of errors that is managed (AI Controllers and EtherCAT slaves*1). You can use the troubleshooting functions of Sysmac Studio or the Troubleshooter on an HMI to check the error details and find corrections for them.

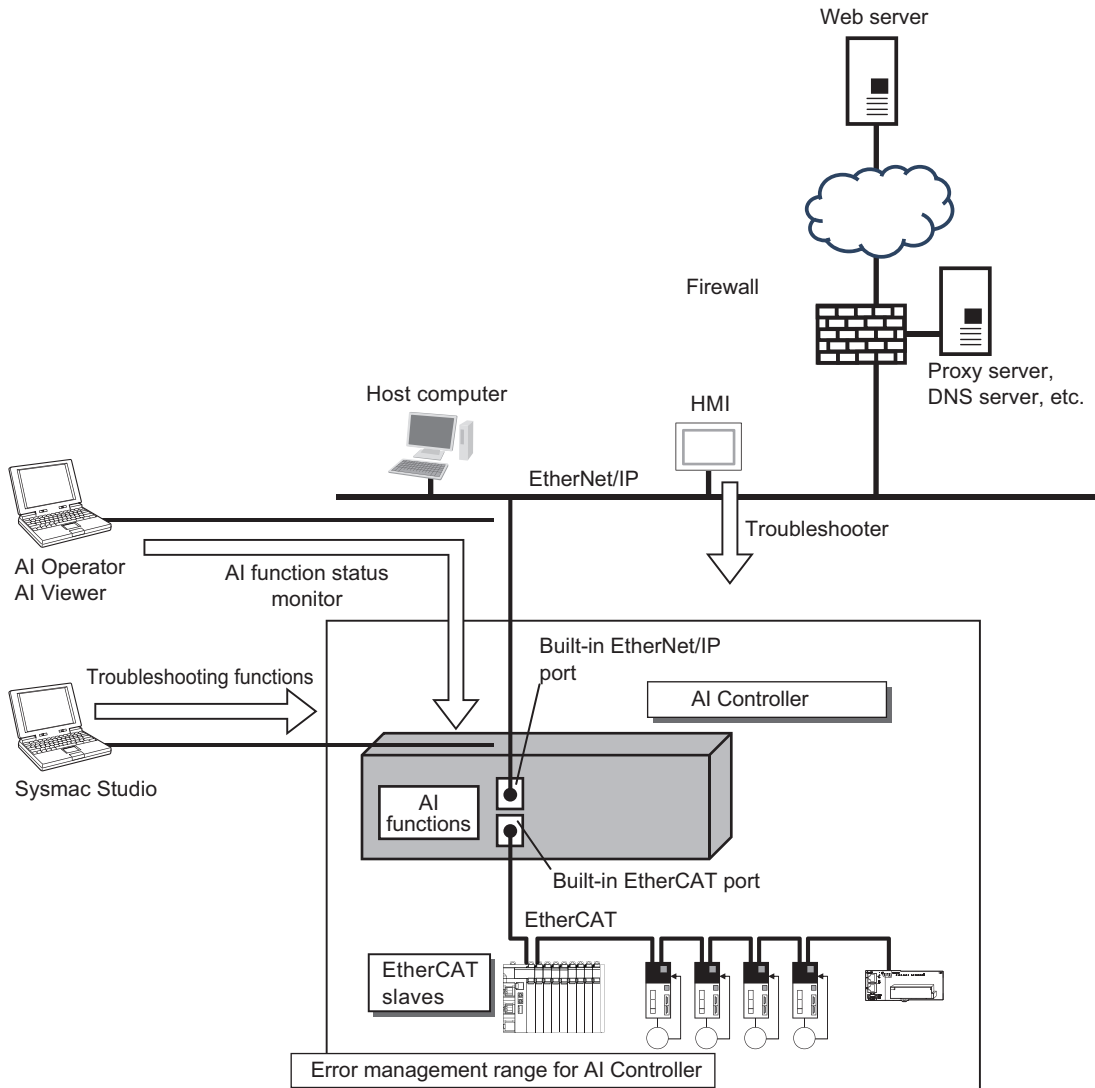

*1. Only Sysmac devices are supported. For information on EtherCAT slaves of the Sysmac devices, refer to the *NJ/NX-series CPU Unit Built-in EtherCAT Port User's Manual (Cat.No. W505)* or the *NY-series Industrial Panel PC / Industrial Box PC Built-in EtherCAT Port User's Manual (Cat. No. W562)*.

8-1-1 How to Check for Errors

You can check to see if an error has occurred with the following methods.

Checking method	What you can check
Checking the indicators	You can check the operating status of the AI Controller

Checking method	What you can check
Checking with the troubleshooting function of Sysmac Studio	You can check for current Controller errors, a log of past Controller errors, error sources, error causes, and corrections.
Checking with the Troubleshooter of an HMI*1	You can check for current Controller errors, a log of past Controller errors, error sources, error causes, and corrections.
Checking with Instruction That Gets Error Status	You can check the highest-level status and highest-level event code in the current Controller errors.
Checking with system-defined variables	You can check the current Controller error status for each function module.

*1. To perform troubleshooting from an HMI, connect the HMI to the built-in EtherNet/IP port on the AI Controller.

This section describes the above checking methods as follows.

● Checking the Indicators

For an NX-series AI Controller, you can use the PWR indicator on the Power Supply Unit and the RUN and ERROR indicators on the AI Controller to check the error status. Refer to the *NJ/NX-series Troubleshooting Manual (Cat. No. W503)* for details.

For an NY-series AI Controller, you can use the PWR, RUN, and ERROR indicators on the AI Controller to check the error status. Refer to the *NY-series Troubleshooting Manual (Cat. No. W564)* for details.

● Checking with the Troubleshooting Function of Sysmac Studio

When an error occurs, you can connect Sysmac Studio to the AI Controller online to check for current Controller errors and the log of past Controller errors. You can also check the cause of the error and corrections. For details, refer to the *NJ/NX-series Troubleshooting Manual (Cat. No. W503)* or the *NY-series Troubleshooting Manual (Cat. No. W564)*. For troubleshooting information when the Sysmac Studio cannot connect to the AI Controller, refer to the *Sysmac Studio Version 1 Operation Manual (Cat. No. W504)*.

● Checking with the Troubleshooter of an HMI

When an error occurs, if you can connect communications between an HMI and the Controller, you can check for current Controller errors and the log of past Controller errors. You can also check the cause of the error and corrections. For details, refer to the *NJ/NX-series Troubleshooting Manual (Cat. No. W503)* or the *NY-series Troubleshooting Manual (Cat. No. W564)*.

● Checking with Instruction That Gets Error Status

In the user program, you can get the error status with the instruction to get error information for each function module.

The following table lists the instruction that are used to get error information for AI functions.

Instruction	Name	Function
GetPLCError	Get PLC Controller Error Status	Gets the highest-level status (partial fault or minor fault) and the highest-level event code of the current Controller errors in the PLC Function Module.

For details on the Get PLC Controller Error Status instruction, refer to the *NJ/NX-series Instructions Reference Manual (Cat. No. W502)* or the *NY-series Instructions Reference Manual (Cat. No. W560)*.

● Checking with System-defined Variables

AI function errors can be checked with the following system-defined variables.

Variable name	Data type	Name	Function
_PLC_ErrSta	WORD	PLC Function Module Error Status	Displays the status of all the errors that occur in the PLC Function Module.

Each status of the AI functions can be checked with the following system-defined variables.

Variable name	Data type	Name	Function
_TSDB_Status	_sTSDB_STATUS	TSDB Service Status	Shows the operation status of the TSDB service.
_TSDB_TSSta	ARRAY[0..31] OF _sTSDB_TSSTA	TimeSeries Status	Shows the TimeSeries status.
_FE_Status	_eFE_STATUS	Feature Extraction Service Status	Shows the status of the feature extraction service.
_MLE_Status	_eMLE_STATUS	Machine Learning Service Status	Shows the status of the machine learning service.

8-1-2 Errors Related to the AI Functions

This section describes errors that are related to the AI functions. For details on the errors that are related to the function modules except for the AI functions, refer to the *NJ/NX-series Troubleshooting Manual (Cat. No. W503)* or the *NY-series Troubleshooting Manual (Cat. No. W564)*.

● Classification

The AI function errors are classified into the following categories according to the error sources.

Classification	Event source	Event source details	Event log category		
			System log	Access log	User-defined event log
Errors for self diagnosis*1	PLC Function Module	---	YES	NO	NO
Time Series Database Function	PLC Function Module	TSDB	YES	NO	NO
Feature Value/ Machine Learning Function	PLC Function Module	FE/MLE	YES	YES	NO
WebAPI Connection Function	PLC Function Module	WebAPI	YES	YES	NO
Time series database instruction	PLC Function Module	Instructions	YES	NO	NO

*1. NY5□2-Z□□□ only

● Event Levels

This section describes the operation of the AI functions in each event level.

Event Levels	Operation
Major fault	The control operations of the entire AI Controller stop for errors in this event level.

Event Levels	Operation
Partial fault	The control operations of one of the function modules in the AI Controller stop for errors in this event level. If an error occurs in locations described above, the entire function are stopped.
Minor fault	Part of the control operations of each function module in the AI Controller stop for errors in this event level.
Observation	These errors do not affect the control operations of the AI Controller. The observation notifies you of potential problems before they develop into a minor fault level error or worse.
Information	Events that are classified as information that do not indicate errors.

● Error of the AI Functions

The following tables list events according to the error levels.

- Errors for Self Diagnosis (NY5□2-Z□□□ only)

Event Levels	Event name
Major fault	None
Partial fault	None
Minor fault	None
Observation	<ul style="list-style-type: none"> • Expanded Storage Life • Expanded Storage Data Corrupted
Information	Expanded storage available

- Time Series Database Function

Event Levels	Event name
Major fault	None
Partial fault	None
Minor fault	<ul style="list-style-type: none"> • TimeSeries Creation Failed • TimeSeries Deletion Failed • TimeSeries Record Export Failed • Time Series Database Setting Error • TSDB Service Startup Failed • TimeSeries Setting Update Failed • TSDB Service Memory Allocation Failed • TimeSeries Error • TimeSeries Open Failed • Timeout Occurred • TimeSeries Record Addition Request Lost • TimeSeries Record Addition Failed • TimeSeries Time Backward Counter Overflow • TimeSeries Time Index Overflow
Observation	None
Information	<ul style="list-style-type: none"> • TSDB Service Started • TSDB Service Stopped • TSDB Service Shutdown • Sampling Started • Sampling Stopped • Export Started • Export Stopped • TimeSeries Setting Updated

- Feature Value/Machine Learning Function

Event Levels	Event name
Major fault	None
Partial fault	None
Minor fault	<ul style="list-style-type: none"> • Feature Extraction Setting Error • PLC System Processing Error • Machine Learning Service Setting Error
Observation	PLC System Processing Error
Information	<ul style="list-style-type: none"> • Feature Extraction Setting Changed • Feature Extraction Service Stopped • Feature Extraction Service Started • Machine Learning Service Setting Changed • Machine Learning Service Stopped • Machine Learning Service Started

- WebAPI Connection Function

Event Levels	Event name
Major fault	None
Partial fault	None
Minor fault	<ul style="list-style-type: none"> • WebAPI Connection Service Setting Error • WebAPI Connection Service System Processing Error • Directory Access Failed • File Deletion Failed • File Upload Failed
Observation	WebAPI Connection Service Root Certificate Expiration Notice
Information	<ul style="list-style-type: none"> • WebAPI Connection Service Started • WebAPI Connection Service Stopped • WebAPI Connection Service Setting Updated • File Upload Succeeded • WebAPI Connection Service Certificate Imported

- Time Series Database Instruction

Event Levels	Event name
Major fault	None
Partial fault	None
Minor fault	None
Observation	<ul style="list-style-type: none"> • Export in Progress • Insufficient TimeSeries Resources • TSDB Service Control Disabled
Information	None

8-2 Troubleshooting

8-2-1 Error Table

This section describes a list of errors (events) that can occur on the AI Controller uniquely.

Interpreting Error Table

The contents of the error tables are described below.

Item	Description
Event code	The event code of the error in the AI Controller is given. The codes are displayed in eight hexadecimal digits.
Event name	The name of the error is given.
Meaning	A short description of the error is given.
Assumed cause	The assumed cause of the error is given.
Level	The level of influence on control is given. The abbreviations have the following meanings. <ul style="list-style-type: none"> • Maj: Major fault level • Prt: Partial fault level • Min: Minor fault level • Obs: Observation • Info: Information The symbol has the following meaning. <ul style="list-style-type: none"> • ○: Event levels that are defined by the system.
Reference	The page number of the manual that provides details on the event is given.

Errors for Self Diagnosis (NY5□2-Z□□□ Only)

Event code	Event name	Meaning	Assumed cause	Level					Reference
				Maj	Prt	Min	Obs	Info	
00140000 hex	Expanded Storage Life	The specified number of deletion for the expanded storage was exceeded. Or, the number of bad blocks exceeded the specified value.	The expanded storage reached its service life.				○		page 8-17

Event code	Event name	Meaning	Assumed cause	Level					Reference
				Maj	Prt	Min	Obs	Info	
10140000 hex	Expanded Storage Data Corrupted	A file that must be in the expanded storage is missing or corrupted.	<ul style="list-style-type: none"> The power supply to the Controller was interrupted while the HDD or SSD was being accessed (HDD indicator was lit). The power supply to the Controller was interrupted momentarily while the HDD or SSD was being accessed (HDD indicator was lit). The expanded storage has failed. 				○		page 8-18
90A10000 hex	Expanded Storage Available	The expanded storage can be used.	The expanded storage can be used.					○	page 8-18

Time Series Database

Event code	Event name	Meaning	Assumed cause	Level					Reference
				Maj	Prt	Min	Obs	Info	
14F00000 hex	TimeSeries Creation Failed	Creating TimeSeries failed.	<ul style="list-style-type: none"> The directory where the TimeSeries is stored, cannot be accessed. Insufficient storage capacity 			○			page 8-19
14F10000 hex	TimeSeries Deletion Failed	Deleting TimeSeries failed.	TimeSeries cannot be accessed.			○			page 8-19
14F20000 hex	TimeSeries Record Export Failed	Exporting records from the TimeSeries to a CSV file failed.	<ul style="list-style-type: none"> The file system returned an error. Accessing the export output file failed. Export was interrupted because the TimeSeries close or the TSDB service shutdown was executed during export. 			○			page 8-20

Event code	Event name	Meaning	Assumed cause	Level					Reference
				Maj	Prt	Min	Obs	In-fo	
35960000 hex	Time Series Database Setting Error	There is an error in the time series database setting.	<ul style="list-style-type: none"> A variable that was not registered in the Sysmac Studio was specified for the Time Series Database. Power was interrupted while the setting was being downloaded. Power was interrupted during the Clear All Memory operation. Power was interrupted during the restore operation. Non-volatile memory failed. 			○			page 8-21
35970000 hex	TSDB Service Startup Failed	Starting the TSDB service failed.	There is an error in the setting file of the Time Series Database.			○			page 8-21
35980000 hex	TimeSeries Setting Update Failed	Updating the TimeSeries settings failed.	<ul style="list-style-type: none"> There is an error in the record setting. Memory resources are insufficient. 			○			page 8-22
44640000 hex	TSDB Service Memory Allocation Failed	The TSDB Service failed to allocate memory.	The TSDB Service failed to allocate memory.			○			page 8-22
44650000 hex	TimeSeries Error	The TimeSeries corruption was detected.	Power was interrupted during access to the TimeSeries.			○			page 8-23
44670000 hex	TimeSeries Open Failed	Opening the TimeSeries failed.	<ul style="list-style-type: none"> The TSDB service is not started. TimeSeries cannot be accessed. The TimeSeries memory is corrupted. The TimeSeries setting that is saved in the expanded storage and the set values for the Time Series Database do not match. Power was interrupted during access to the TimeSeries. 			○			page 8-24
65400000 hex	Timeout Occurred	A timeout occurred while records are added to TimeSeries or data exports to a CSV file.	The file access delayed due to insufficient memory space or memory error (access prohibited, hardware failure, or locked).			○			page 8-25
95930000 hex	TimeSeries Record Addition Request Lost	A record addition request to the TimeSeries was lost.	A delay of access speed occurred to the directory where the TimeSeries is stored.			○			page 8-26

Event code	Event name	Meaning	Assumed cause	Level					Reference
				Maj	Prt	Min	Obs	In-fo	
95940000 hex	TimeSeries Record Ad- dition Failed	Adding records to the TimeSeries failed.	<ul style="list-style-type: none"> The directory where the TimeSeries is stored, cannot be accessed. A record cannot be added to the TimeSeries. 			○			page 8-27
95960000 hex	TimeSeries Time Back- ward Coun- ter Overflow	The order reversal of records and time stamps stor- ed in the TimeSer- ies occurred more than the specified number of times.	The time of the AI Controller is set to older than the current time.			○			page 8-28
95970000 hex	TimeSeries Time Index Overflow	Writing records of the same time stamp occurred more than the specified number of times.	Records with the same time stamp are stored in sequence.			○			page 8-28
95900000 hex	TSDB Serv- ice Started	The TSDB service entered the run- ning state.	The TSDB service entered the running state.					○	page 8-29
95910000 hex	TSDB Serv- ice Stopped	The TSDB service entered the idle state.	The TSDB service entered the idle state.					○	page 8-29
95920000 hex	TSDB Serv- ice Shut- down	The TSDB service entered the shut- down state.	The TSDB service entered the shutdown state.					○	page 8-30
95980000 hex	Sampling Started	The sampling of the Time Series Database was started.	The sampling of the Time Ser- ies Database was started.					○	page 8-30
95990000 hex	Sampling Stopped	The sampling of the Time Series Database was stopped.	The sampling of the Time Ser- ies Database was stopped.					○	page 8-31
959A0000 hex	Export Start- ed	The export of the Time Series Data- base was started.	The export of the Time Series Database was started.					○	page 8-31
959B0000 hex	Export Stop- ped	The export of the Time Series Data- base was stop- ped.	The export of the Time Series Database was stopped.					○	page 8-32
959C0000 hex	TimeSeries Setting Up- dated	The TimeSeries setting was updat- ed.	The TimeSeries setting (basic controller setting) was updated.					○	page 8-32

Feature Value/Machine Learning Function

● Feature Extraction Function

Event code	Event name	Meaning	Assumed cause	Level					Reference
				Maj	Prt	Min	Obs	Info	
35EB0000 hex	Feature Extraction Setting Error	There is an error in the settings of the Feature Extraction Function.	<ul style="list-style-type: none"> There is a variable that is not registered in the Sysmac Studio. Power was interrupted while the setting was being downloaded. Power was interrupted during the Clear All Memory operation. Power was interrupted during the restore operation. Non-volatile memory failed. 			○			page 8-33
446F0000 hex	PLC System Processing Error	An error was detected in the PLC Function Module.	An error occurred in the software or hardware.			○			page 8-34
44710000 hex	Feature Extraction Service TimeSeries Write Error	Writing from the feature extraction service to TimeSeries failed.	<ul style="list-style-type: none"> The TSDB service was stopped. The TSDB service was shut down. There is insufficient free space in the internal buffer of the TSDB service. The SD Memory Card was removed. (for NX-series AI Controllers) The expanded storage was removed. (for NY-series AI Controllers) 				○		page 8-35
95E30000 hex	Feature Extraction Setting Changed	The setting of the Feature Extraction Function was updated.	<ul style="list-style-type: none"> The setting of the Feature Extraction Function was changed with the AI Operator. The setting of the Feature Extraction Function was changed by the Clear All Memory operation. The setting of the Feature Extraction Function was changed by the download operation. The setting of the Feature Extraction Function was changed by the restore operation. 					○	page 8-36
95E40000 hex	Feature Extraction Service Stopped	The Feature Extraction Function entered the idle state.	The Feature Extraction Function entered the idle state.					○	page 8-36

Event code	Event name	Meaning	Assumed cause	Level					Reference
				Maj	Prt	Min	Obs	Info	
95E50000 hex	Feature Extraction Service Started	The Feature Extraction Function entered the running state.	The Feature Extraction Function entered the running state.					○	page 8-37

● Machine Learning Function

Event code	Event name	Meaning	Assumed cause	Level					Reference
				Maj	Prt	Min	Obs	Info	
35EA0000 hex	Machine Learning Service Setting Error	There is an error in the machine learning function setting.	<ul style="list-style-type: none"> There is a variable that is not registered in the Sysmac Studio. Power was interrupted while the setting was being downloaded. Power was interrupted during the Clear All Memory operation. Power was interrupted during the restore operation. A format error of the learned data occurred. An mismatch between the setting and the learned data occurred. 			○			page 8-38
446E0000 hex	PLC System Processing Error	An error was detected in the PLC Function Module.	An error occurred in the software or hardware.			○			page 8-39
44700000 hex	Machine Learning Service TimeSeries Write Error	Writing from the machine learning service to TimeSeries failed.	<ul style="list-style-type: none"> The TSDB service was stopped. The TSDB service was shut down. There is insufficient free space in the internal buffer of the TSDB service. The SD Memory Card was removed. (for NX-series AI Controllers) The expanded storage was removed. (for NY-series AI Controllers) 				○		page 8-40

Event code	Event name	Meaning	Assumed cause	Level					Reference
				Maj	Prt	Min	Obs	In-fo	
95E00000 hex	Machine Learning Service Setting Changed	The setting of the Machine Learning Function or the learned data was updated.	<ul style="list-style-type: none"> The setting of the Machine Learning Function or the learned data was changed with the AI Operator. The setting of the Machine Learning Function was changed by the Clear All Memory operation. The setting of the Machine Learning Function was changed by the restore operation. 					○	page 8-41
95E10000 hex	Machine Learning Service Stopped	The Machine Learning Function entered the idle state.	The status of the Machine Learning Function entered the reading or error state.					○	page 8-41
95E20000 hex	Machine Learning Service Started	The Machine Learning Function entered the running state.	The status of the Machine Learning Function entered the idle or running state.					○	page 8-42

WebAPI Connection Function

Event code	Event name	Meaning	Assumed cause	Level					Reference
				Maj	Prt	Min	Obs	In-fo	
35F40000 hex	WebAPI Connection Service Setting Error	There is an error in the WebAPI connection service setting.	<ul style="list-style-type: none"> There is a setting error. Power was interrupted while the setting was being downloaded. Power was interrupted during the Clear All Memory operation. Power was interrupted during the restore operation. Non-volatile memory failed. 			○			page 8-43
44780000 hex	WebAPI Connection Service System Processing Error	A fatal error was detected in the WebAPI connection service.	A fatal error was detected in the WebAPI connection service.			○			page 8-44

Event code	Event name	Meaning	Assumed cause	Level					Reference
				Maj	Prt	Min	Obs	In-fo	
65450000 hex	Directory Access Failed	Accessing to the directory that is stored the transfer file failed.	<ul style="list-style-type: none"> The directory specified the source file for transfer does not exist. The SD Memory Card is not inserted (when the SD Memory Card was specified for the transfer source) The SD Memory Card was removed during the execution of file upload (when the SD Memory Card was specified for the transfer source) 			○			page 8-44
65460000 hex	File Deletion Failed	Deleting the file stored in the transfer source directory failed after the file is transferred.	The SD Memory Card is write-protected.			○			page 8-45
85180000 hex	File Upload Failed	Uploading a file to the HTTP server failed.	<ul style="list-style-type: none"> The specified destination URL is incorrect. The specified HTTP server stopped the service. There is an incorrect equipment setting (Ethernet switch, Proxy server, and DNS server) in the communications path. The Ethernet cable connector is disconnected. The Ethernet cable is broken. An error occurred in the communications path. 			○			page 8-46
65470000 hex	WebAPI Connection Service Root Certificate Expiration Notice	The root certificate of the WebAPI connection service will expire in one month.	It was detected that the root certificate of the WebAPI connection service would expire in one month.				○		page 8-47
95F10000 hex	WebAPI Connection Service Started	The WebAPI connection service was started.	The WebAPI connection service was started.					○	page 8-48
95F20000 hex	WebAPI Connection Service Stopped	The WebAPI connection service was stopped.	The WebAPI connection service was stopped.					○	page 8-48
95F30000 hex	WebAPI Connection Service Setting Updated	The WebAPI connection service setting was updated.	The WebAPI connection service setting was updated.					○	page 8-49

Event code	Event name	Meaning	Assumed cause	Level					Reference
				Maj	Prt	Min	Obs	In-fo	
95F40000 hex	File Upload Succeeded	The file upload to the HTTP server has succeeded.	The file transfer to the HTTP server has succeeded.					○	page 8-49
95F50000 hex	WebAPI Connection Service Certificate Imported	The root certificate of the WebAPI connection service was imported.	The root certificate of the WebAPI connection service was imported.					○	page 8-50

Time Series Database Instructions

The following list shows errors (i.e., events) that can occur in the time series database instructions.

Event code	Event name	Meaning	Assumed cause	Level					Reference
				Maj	Prt	Min	Obs	In-fo	
54014C0C hex	Insufficient TimeSeries Resources	There is not sufficient resources to execute the Time Series Database Instruction.	Insufficient free space in the internal buffer of the TSDB service				○		page 8-50
54014C0D hex	TSDB Service Control Disabled	While the TSDB service was in the <i>Error</i> or <i>Shutdown</i> state, <i>Start</i> command or <i>Stop</i> command was executed.	<ul style="list-style-type: none"> The relevant instruction was executed while the TSDB service was shutting down. The relevant instruction was executed while the TSDB service was in the error state. 				○		page 8-51

8-2-2 Error Description

This section provides details of the errors.

Interpreting Error Descriptions

The items that are used to describe individual errors (events) are described in the following copy of an error table.

Event name	Gives the name of the error.			Event code	Gives the code of the error.		
Meaning	Gives a short description of the error.						
Source	Gives the source of the error.		Source details	Gives details on the source of the error.		Detection timing	Tells when the error is detected.
Error attributes	Level	Tells the level of influence on control.* ¹	Recovery	Gives the recovery method.* ²		Log category	Tells which log the error is saved in.* ³

Effects	User program	Tells what will happen to execution of the user program.*4	Operation	Provides special information on the operation that results from the error.
System-defined variables	Variable	Data type	Name	
	Lists the variable names, data types, and meanings for system-defined variables that provide direct error notification, that are directly affected by the error, or that contain settings that cause the error.			
Cause and correction	Assumed cause	Correction	Prevention	
	Lists the possible causes, corrections, and preventive measures for the error.			
Attached information	This is the attached information that is displayed by Sysmac Studio or HMI.*5			
Precautions/Remarks	Provides precautions, restrictions, and supplemental information. If the user can set the event level, the event levels that can be set, the recovery method, operational information, and other information is also provided.			

- *1. One of the following:
Major fault: Major fault level, Partial fault: Partial fault level, Minor fault: Minor fault level, Observation, Information
- *2. After the correction is performed, one of the following methods is used to reset the Controller error state:
Automatic recovery: Normal status is restored automatically when the cause of the error is removed.
Error reset: Normal status is restored when the error is reset after the cause of the error is removed.
Cycle the power supply: Normal status is restored when the power supply to the Controller is turned OFF and then back ON after the cause of the error is removed.
Controller reset: Normal status is restored when the Controller is reset after the cause of the error is removed.
- *3. One of the following:
System: System event log
Access: Access event log
- *4. One of the following:
Continues: Execution of the user program will continue.
Stops: Execution of the user program stops.
Starts: Execution of the user program starts.
- *5. Refer to the *NJ/NX-series Troubleshooting Manual (Cat. No. W503)* or the *NY-series Troubleshooting Manual (Cat. No. W564)* for the applicable range of the HMI Troubleshooter.

Errors for Self Diagnosis (NY5□2-Z□□□ Only)

Event name	Expanded Storage Life		Event code	00140000 hex		
Meaning	The specified number of deletion for the expanded storage was exceeded. Or, the number of bad blocks exceeded the specified value.					
Source	PLC Function Module		Source details	---	Detection timing	At power ON, Controller reset or periodically
Error attributes	Level	Observation	Recovery	---	Log category	System
Effects	User program	Not affected.	Operation	Not affected.		
System-defined variables	Variable	Data type		Name		
	---	---		---		
Cause and correction	Assumed cause		Correction		Prevention	
	The expanded storage reached its service life.		Replace the expanded storage.		---	
Attached information	None					
Precautions/Remarks	If you replace the expanded storage, you cannot migrate the data stored in the old expanded storage. For details on how to replace the expanded storage, refer to <i>Section 7 Maintenance</i> on page 7-1.					

Event name	Expanded Storage Data Corrupted		Event code	10140000 hex	
Meaning	A file that must be in the expanded storage is missing or corrupted.				
Source	PLC Function Module		Source details	---	Detection timing At power ON or Controller reset
Error attributes	Level	Observation	Recovery	Cycle the power supply or reset the Controller after the correction	Log category System
Effects	User program	Not affected.	Operation	Not affected.	
System-defined variables	Variable		Data type		Name
	_ExtendedStorage2Ready		BOOL		Extended Storage 2 Ready Flag
Cause and correction	Assumed cause		Correction		Prevention
	The power supply to the Controller was interrupted while the HDD or SSD was being accessed (HDD indicator was lit).		Use the Rescue Disk Utility to format the expanded storage, and then download the correct file.		Do not interrupt the power supply to the Controller while the HDD or SSD is being accessed (HDD indicator is lit). Follow the correct shutdown procedure to turn the power off.
	The power supply to the Controller was interrupted momentarily while the HDD or SSD was being accessed (HDD indicator was lit).				<ul style="list-style-type: none"> • Use an UPS and supply power at the rated voltage. • Do not remove the expanded storage while the power is ON.
	The expanded storage has failed.		If this error occurs even though the above problem does not exist, replace the expanded storage.		---
Attached information	None				
Precautions/Remarks	<ul style="list-style-type: none"> • If this event occurs, the Time Series Database, the Feature Value/Machine Learning Function may not operate normally. • If you replace the expanded storage, you cannot migrate the data stored in the old expanded storage. • For details on how to replace the expanded storage, refer to <i>Section 7 Maintenance</i> on page 7-1. 				

Event name	Expanded Storage Available		Event code	90A10000 hex	
Meaning	The expanded storage can be used.				
Source	PLC Function Module		Source details	---	Detection timing At power ON or Controller reset
Error attributes	Level	Information	Recovery	---	Log category System
Effects	User program	Not affected.	Operation	Not affected.	
System-defined variables	Variable		Data type		Name
	_ExtendedStorage2Ready		BOOL		Extended Storage 2 Ready Flag
Cause and correction	Assumed cause		Correction		Prevention
	The expanded storage can be used.		---		---
Attached information	None				
Precautions/Remarks	---				

Time Series Database

Event name	TimeSeries Creation Failed			Event code	14F00000 hex	
Meaning	Creating TimeSeries failed.					
Source	PLC Function Module		Source details	TSDB	Detection timing	When the TimeSeries creation fails
Error attributes	Level	Minor fault	Recovery	Execute the TimeSeries creation again	Log category	System
Effects	User program	Continues.	Operation	Not affected.		
System-defined variables	Variable	Data type		Name		
	None	---		---		
Cause and correction	Assumed cause		Correction		Prevention	
	The directory where the TimeSeries is stored, cannot be accessed.		Change the attribute of the directory where the TimeSeries is stored, to enable writing and then download the TimeSeries setting again.		Change the attribute of the directory where the TimeSeries is stored, to enable writing.	
	Insufficient storage capacity		Increase the free space of the storage where the TimeSeries is stored and then download the TimeSeries setting again.		Check the free space of the storage where the TimeSeries is stored.	
Attached information	Attached information 1: TimeSeries Name (beginning 15 characters)					
Precautions/Remarks	None					

Event name	TimeSeries Deletion Failed			Event code	14F10000 hex	
Meaning	Deleting TimeSeries failed.					
Source	PLC Function Module		Source details	TSDB	Detection timing	When the TimeSeries deletion fails
Error attributes	Level	Minor fault	Recovery	Execute the TimeSeries deletion again	Log category	System
Effects	User program	Continues.	Operation	Not affected.		
System-defined variables	Variable	Data type		Name		
	None	---		---		
Cause and correction	Assumed cause		Correction		Prevention	
	TimeSeries cannot be accessed.		Check the TimeSeries file and the setting (read attribute, etc) of the directory where the TimeSeries was stored.		Check the TimeSeries file and the setting (read attribute, etc) of the directory where the TimeSeries was stored.	
Attached information	Attached information 1: TimeSeries Name (beginning 15 characters)					
Precautions/Remarks	None					

Event name	TimeSeries Record Export Failed		Event code	14F20000 hex	
Meaning	Exporting records from the TimeSeries to a CSV file failed.				
Source	PLC Function Module		Source details	TSDB	Detection timing When the TimeSeries record export fails
Error attributes	Level	Minor fault	Recovery	Cycle the power supply or reset the Controller.	Log category System
Effects	User program	Continues.	Operation	Not affected.	
System-defined variables	Variable	Data type		Name	
	None	---		---	
Cause and correction	Assumed cause		Correction		Prevention
	The file system returned an error.		Restart the AI Controller.		---
	Accessing the export output file failed.		Check the status, volume, and write allowance setting of the storage to which the file is output.		Check the status, volume, and write allowance setting of the storage to which the file is output, and then execute the command.
	Export was interrupted because the TimeSeries close or the TSDB service shutdown was executed during export.		Since the export was interrupted, the output file may be corrupted. Check the output file.		Shut down the TSDB service in a correct procedure.
Attached information	Attached information 1: TimeSeries Name (beginning 15 characters) Attached Information 2: Cause of the error 4C00 hex: TSDB Service Not Started 4C02 hex: TimeSeries Handle Out Of Range 4C04 hex: No Corresponding Record Found 4C05 hex: Exporting 4C0B hex: TimeSeries Access Failed 4C0C hex: Insufficient resources 4C14 hex: Insufficient Capacity in Export Destination				
Precautions/Remarks	None				

Event name	Time Series Database Setting Error		Event code	35960000 hex		
Meaning	There is an error in the time series database setting.					
Source	PLC Function Module		Source details	TSDB	Detection timing	At power ON, Controller re-set, or when downloading
Error attributes	Level	Minor fault	Recovery	Automatic recovery	Log category	System
Effects	User program	Continues.	Operation	Not affected.		
System-defined variables	Variable		Data type		Name	
	None		---		---	
Cause and correction	Assumed cause		Correction		Prevention	
	A variable that was not registered in the Sysmac Studio was specified for the Time Series Database.		Register the variable from the Sysmac Studio and then download the settings.		Download from the Sysmac Studio first and then from the AI Operator next.	
	Power was interrupted while the setting was being downloaded.		Perform the Clear All Memory operation or download the settings.		Do not interrupt the power supply during download of the settings, Clear All Memory, or restore operations.	
	Power was interrupted during the Clear All Memory operation.					
	Power was interrupted during the restore operation.					
Non-volatile memory failed.		Replace the AI Controller.		None		
Attached information	Attached information 1: TimeSeries Name (beginning 15 characters)					
Precautions/Remarks	None					

Event name	TSDB Service Startup Failed		Event code	35970000 hex		
Meaning	Starting the TSDB service failed.					
Source	PLC Function Module		Source details	TSDB	Detection timing	When the TSDB service startup fails
Error attributes	Level	Minor fault	Recovery	---	Log category	System
Effects	User program	Continues.	Operation	Not affected.		
System-defined variables	Variable		Data type		Name	
	_TSDB_Status		_sTSDB_STATUS		TSDB Service Status	
Cause and correction	Assumed cause		Correction		Prevention	
	An error occurred in the setting file of the Time Series Database		Correct the time series database settings (basic controller setting or variable registration) and download the settings from the AI Operator.		Make sure that the time series database settings (basic controller setting or variable registration) are correct before downloading the settings.	
Attached information	None					
Precautions/Remarks	None					

Event name	TimeSeries Setting Update Failed		Event code	35980000 hex		
Meaning	Updating the TimeSeries settings failed.					
Source	PLC Function Module		Source details	TSDB	Detection timing	When the time-series database setting is downloaded from the AI Operator
Error attributes	Level	Minor fault	Recovery	Download the setting again	Log category	System
Effects	User program	Continues.	Operation	Not affected.		
System-defined variables	Variable	Data type		Name		
	None	---		---		
Cause and correction	Assumed cause		Correction		Prevention	
	There is an error in the record setting.		Check the record settings (variable registration, equipment event or data set registration) and then download the settings again.		Make sure that the record settings (variable registration, equipment event or data set registration) are correct and then download the settings.	
	Insufficient memory resources		Restart the AI Controller.		---	
Attached information	Attached information 1: TimeSeries Name (beginning 15 characters) Attached Information 2: Cause of the error 4C03 hex: Setting error 4C0C hex: Insufficient resources					
Precautions/Remarks	None					

Event name	TSDB Service Memory Allocation Failed		Event code	44640000 hex		
Meaning	The TSDB service failed to allocate memory.					
Source	PLC Function Module		Source details	TSDB	Detection timing	Continuously
Error attributes	Level	Minor fault	Recovery	---	Log category	System
Effects	User program	Continues.	Operation	Not affected.		
System-defined variables	Variable	Data type		Name		
	None	---		---		
Cause and correction	Assumed cause		Correction		Prevention	
	The TSDB service failed to allocate memory.		End unnecessary programs.		Do not run unnecessary programs.	
Attached information	None					
Precautions/Remarks	None					

Event name	TimeSeries Error		Event code	44650000 hex	
Meaning	The TimeSeries corruption was detected.				
Source	PLC Function Module		Source details	TSDB	Detection timing When the TimeSeries corruption is detected
Error attributes	Level	Minor fault	Recovery	---	Log category System
Effects	User program	Continues.	Operation	Not affected.	
System-defined variables	Variable		Data type		Name
	None		---		---
Cause and correction	Assumed cause		Correction		Prevention
	Power was interrupted during access to the TimeSeries.		Download the time series database settings from the AI Operator again, and then reconstruct the TimeSeries.		Do not interrupt the power supply during access to the TimeSeries.
Attached information	Attached information 1: TimeSeries Name (beginning 15 characters)				
Precautions/Remarks	None				

Event name	TimeSeries Open Failed		Event code	44670000 hex	
Meaning	Opening the TimeSeries failed.				
Source	PLC Function Module		Source details	TSDB	Detection timing When opening the TimeSeries fails
Error attributes	Level	Minor fault	Recovery	---	Log category System
Effects	User program	Continues.	Operation	Not affected.	
System-defined variables	Variable		Data type		Name
	_TSDB_TSSta		ARRAY [0..31] OF _sTSDB_TSSTA		TimeSeries Status
Cause and correction	Assumed cause		Correction		Prevention
	The TSDB service is not started.		Start the TSDB service.		Check the status of the TSDB service before you perform the operation.
	TimeSeries cannot be accessed.		<ul style="list-style-type: none"> • Insert the TimeSeries storage correctly. • Remove write protection from the TimeSeries storage. 		<ul style="list-style-type: none"> • Insert the storage correctly. • Do not set the read attribute to the storage.
	The TimeSeries memory is corrupted.		Replace the TimeSeries storage.		Turn OFF the AI Controller power supply in the correct procedure.
	The TimeSeries setting that is saved in the expanded storage and the set values for the Time Series Database do not match.		Download the time series database settings from the AI Operator again, and then reconstruct the TimeSeries.		If you download the time series database settings after the settings are changed, reconstruct the TimeSeries.
Power was interrupted during access to the TimeSeries.				Do not interrupt the power supply during access to the TimeSeries.	
Attached information	Attached information 1: TimeSeries Name (beginning 15 characters) Attached Information 2: Code of cause of the error 4C00 hex: TSDB Service Not Started 4C03 hex: Setting error 4C08 hex: TimeSeries Open Failed 4C0B hex: TimeSeries Access Failed 4C12 hex: TimeSeries Database File Corrupted				
Precautions/Remarks	None				

Event name	Timeout Occurred		Event code	65400000 hex	
Meaning	A timeout occurred while records are added to TimeSeries or data exports to a CSV file.				
Source	PLC Function Module		Source details	TSDB	Detection timing During the access to the database or the processing to access to the Export file
Error attributes	Level	Minor fault	Recovery	Access to the database again or execute to access to the Export file	Log category System
Effects	User program	Continues.	Operation	Not affected.	
System-defined variables	Variable	Data type		Name	
	None	---		---	
Cause and correction	Assumed cause		Correction		Prevention
	The file access delayed due to insufficient memory space or memory error (access prohibited, hardware failure, or locked).		Check the storage of the TimeSeries or the status, volume, and write allowance setting of the storage to which the CSV file is exported.		Check the storage of the TimeSeries or the status, volume, and write allowance setting of the storage to which the CSV file is exported, and then execute the command.
Attached information	Attached information 1: TimeSeries Name (beginning 15 characters) Attached Information 2: Cause of the error 0: Record addition timeout 1: Record writing or reading timeout during export 2: File open timeout during export 3: File close timeout during export				
Precautions/Remarks	None				

Event name	TimeSeries Record Addition Request Lost		Event code	95930000 hex		
Meaning	A record addition request to the TimeSeries was lost.					
Source	PLC Function Module		Source details	TSDB	Detection timing	When the record addition request to the TimeSeries is lost
Error attributes	Level	Minor fault	Recovery	Execute the addition request again	Log category	System
Effects	User program	Continues.	Operation	Not affected.		
System-defined variables	Variable	Data type		Name		
	None	---		---		
Cause and correction	Assumed cause		Correction		Prevention	
	A delay of access speed occurred to the directory where the TimeSeries is stored.		Increase the access speed to the directory where the TimeSeries is stored.		Increase the access speed to the directory where the TimeSeries is stored and then execute the command.	
Attached information	Attached information 1: TimeSeries Name (beginning 15 characters)					
Precautions/Remarks	None					

Event name	TimeSeries Record Addition Failed		Event code	95940000 hex		
Meaning	Adding records to the TimeSeries failed.					
Source	PLC Function Module		Source details	TSDB	Detection timing	When the TimeSeries record addition fails
Error attributes	Level	Minor fault	Recovery	Execute the record addition again	Log category	System
Effects	User program	Continues.	Operation	Not affected.		
System-defined variables	Variable	Data type		Name		
	None	---		---		
Cause and correction	Assumed cause		Correction		Prevention	
	The directory where the TimeSeries is stored, cannot be accessed.		Take appropriate measures to ensure that the directory where the TimeSeries is stored, can be accessed.		Take appropriate measures to ensure that the directory where the TimeSeries is stored, can be accessed.	
	A record cannot be added to the TimeSeries.		Increase the free space of the storage (output destination of the TimeSeries)*1.		Increase the free space of the storage (output destination of the TimeSeries)*1.	
			Check to see if the storage (output destination of the TimeSeries)*1 is not corrupted.		Check to see if the storage (output destination of the TimeSeries)*1 is not corrupted.	
Attached information	Attached information 1: TimeSeries Name (beginning 15 characters)					
Precautions/Remarks	None					

*1. For NX-series, the output destination of the TimeSeries is the SD Memory Card. For NY-series, this event does not occur.

Event name	TimeSeries Time Backward Counter Overflow		Event code	95960000 hex	
Meaning	The order reversal of records and time stamps stored in the TimeSeries occurred more than the specified number of times.				
Source	PLC Function Module		Source details	TSDB	Detection timing The time backward counter for the TimeSeries is overflowed
Error attributes	Level	Minor fault	Recovery	Delete the TimeSeries and create it again	Log category System
Effects	User program	Continues.	Operation	Not affected.	
System-defined variables	Variable		Data type		Name
	None		---		---
Cause and correction	Assumed cause		Correction		Prevention
	The time of the AI Controller is set to older than the current time.		Delete the TimeSeries and create it again.		Check the time of the AI Controller.
Attached information	Attached information 1: TimeSeries Name (beginning 15 characters)				
Precautions/Remarks	None				

Event name	TimeSeries Time Index Overflow		Event code	95970000 hex	
Meaning	Writing records of the same time stamp occurred more than the specified number of times.				
Source	PLC Function Module		Source details	TSDB	Detection timing The time index for the TimeSeries is overflowed
Error attributes	Level	Minor fault	Recovery	---	Log category System
Effects	User program	Continues.	Operation	Not affected.	
System-defined variables	Variable		Data type		Name
	None		---		---
Cause and correction	Assumed cause		Correction		Prevention
	Records with the same time stamp are stored in sequence.		Store records without the time stamp (auto) or with another time stamp.		Do not write records that have the same time stamp.
Attached information	Attached information 1: TimeSeries Name (beginning 15 characters)				
Precautions/Remarks	None				

Event name	TSDB Service Started			Event code	95900000 hex
Meaning	The TSDB service entered the running state.				
Source	PLC Function Module		Source details	TSDB	Detection timing When the TSDB service is started
Error attributes	Level	Information	Recovery	---	Log category System
Effects	User program	Continues.	Operation	Not affected.	
System-defined variables	Variable		Data type		Name
	_TSDB_Status		_sTSDB_STATUS		TSDB Service Status
Cause and correction	Assumed cause		Correction		Prevention
	The TSDB service entered the running state.		---		---
Attached information	None				
Precautions/Remarks	None				

Event name	TSDB Service Stopped			Event code	95910000 hex
Meaning	The TSDB service entered the idle state.				
Source	PLC Function Module		Source details	TSDB	Detection timing When the TSDB service is stopped
Error attributes	Level	Information	Recovery	---	Log category System
Effects	User program	Continues.	Operation	Not affected.	
System-defined variables	Variable		Data type		Name
	_TSDB_Status		_sTSDB_STATUS		TSDB Service Status
Cause and correction	Assumed cause		Correction		Prevention
	The TSDB service entered the idle state.		---		---
Attached information	None				
Precautions/Remarks	None				

Event name	TSDB Service Shutdown		Event code	95920000 hex	
Meaning	The TSDB service entered the shutdown state.				
Source	PLC Function Module		Source details	TSDB	Detection timing When the TSDB service is shut down
Error attributes	Level	Information	Recovery	---	Log category System
Effects	User program	Continues.	Operation	Not affected.	
System-defined variables	Variable		Data type		Name
	_TSDB_Status		_sTSDB_STATUS		TSDB Service Status
Cause and correction	Assumed cause		Correction		Prevention
	The TSDB service entered the shutdown state.		---		---
Attached information	None				
Precautions/Remarks	None				

Event name	Sampling Started		Event code	95980000 hex	
Meaning	The sampling of the Time Series Database was started.				
Source	PLC Function Module		Source details	TSDB	Detection timing When the sampling is started
Error attributes	Level	Information	Recovery	---	Log category System
Effects	User program	Continues.	Operation	Not affected.	
System-defined variables	Variable		Data type		Name
	_TSDB_SmplSta		ARRAY [0..31] of BOOL		Sampling Execution Flag
Cause and correction	Assumed cause		Correction		Prevention
	The sampling of the Time Series Database was started.		---		---
Attached information	Attached information 1: TimeSeries Name (beginning 15 characters)				
Precautions/Remarks	None				

Event name	Sampling Stopped			Event code	95990000 hex
Meaning	The sampling of the Time Series Database was stopped.				
Source	PLC Function Module		Source details	TSDB	Detection timing When the sampling is stopped
Error attributes	Level	Information	Recovery	---	Log category System
Effects	User program	Continues.	Operation	Not affected.	
System-defined variables	Variable		Data type		Name
	_TSDB_SmplSta		ARRAY [0..31] of BOOL		Sampling Execution Flag
Cause and correction	Assumed cause		Correction		Prevention
	The sampling of the Time Series Database was stopped.		---		---
Attached information	Attached information 1: TimeSeries Name (beginning 15 characters)				
Precautions/Remarks	None				

Event name	Export Started			Event code	959A0000 hex
Meaning	The export of the Time Series Database was started.				
Source	PLC Function Module		Source details	TSDB	Detection timing When the export is started
Error attributes	Level	Information	Recovery	---	Log category System
Effects	User program	Continues.	Operation	Not affected.	
System-defined variables	Variable		Data type		Name
	_TSDB_ExptSta		ARRAY [0..31] of BOOL		Export Execution Flag
Cause and correction	Assumed cause		Correction		Prevention
	The export of the Time Series Database was started.		---		---
Attached information	Attached information 1: TimeSeries Name (beginning 15 characters)				
Precautions/Remarks	None				

Event name	Export Stopped		Event code	959B0000 hex	
Meaning	The export of the Time Series Database was stopped.				
Source	PLC Function Module		Source details	TSDB	Detection timing When the export is stopped
Error attributes	Level	Information	Recovery	---	Log category System
Effects	User program	Continues.	Operation	Not affected.	
System-defined variables	Variable		Data type		Name
	_TSDB_ExpSta		ARRAY [0..31] of BOOL		Export Execution Flag
Cause and correction	Assumed cause		Correction		Prevention
	The export of the Time Series Database was stopped.		---		---
Attached information	Attached information 1: TimeSeries Name (beginning 15 characters)				
Precautions/Remarks	None				

Event name	TimeSeries Setting Updated		Event code	959C0000 hex	
Meaning	The TimeSeries setting was updated.				
Source	PLC Function Module		Source details	TSDB	Detection timing When downloading
Error attributes	Level	Information	Recovery	---	Log category System
Effects	User program	Continues.	Operation	Not affected.	
System-defined variables	Variable		Data type		Name
	None		---		---
Cause and correction	Assumed cause		Correction		Prevention
	The TimeSeries setting (basic controller setting) was updated.		---		---
Attached information	Attached information 1: TimeSeries Name (beginning 15 characters)				
Precautions/Remarks	None				

Feature Value/Machine Learning Function

● Feature Extraction Function

Event name	Feature Extraction Setting Error		Event code	35EB0000 hex		
Meaning	There is an error in the settings of the Feature Extraction Function.					
Source	PLC Function Module		Source details	FE/MLE	Detection timing	When downloading, at power ON, or Controller reset
Error attributes	Level	Minor fault	Recovery	Downloading by the AI Operator or Sysmac Studio	Log category	System
Effects	User program	Continues.	Operation	Not affected.		
System-defined variables	Variable		Data type		Name	
	_FE_Status		_eFE_STATUS		Feature Extraction Service Status	
Cause and correction	Assumed cause		Correction		Prevention	
	There is a variable that is not registered in the Sysmac Studio.		Register the variable from the Sysmac Studio and then download the settings.		Download from the Sysmac Studio first and then from the AI Operator next.	
	Power was interrupted while the setting was being downloaded.		Perform the Clear All Memory operation or download the settings.		Do not interrupt the power supply during download of the settings, Clear All Memory, or restore operations.	
	Power was interrupted during the Clear All Memory operation.					
	Power was interrupted during the restore operation.					
Non-volatile memory failed.		Replace the AI Controller.		None		

Attached information	<p>Attached information 1: Classification for identifying the cause of the error</p> <p>01 hex: Setting error 02 hex: Variable setting error 03 hex: Non-volatile memory access error</p> <p>Attached information 2: Classification for identifying the cause of the error</p> <p>When the value of attached information 1 is 1 01 hex: Setting error</p> <p>When the value of attached information 1 is 2 01 hex: A variable that is not existed was specified 02 hex: A data type that is not permitted was specified 03 hex: A variable with the Constant attribute was specified for the output frame variable of the feature extraction.</p> <p>Attached information 3: Classification for identifying the cause of the error. Only when the value of attached information 1 is 1 or 2</p> <p>65535: A setting error of the Feature Extraction Function shared by equipment events 0 to 127: Equipment event number where an error was detected first (ID corresponding to the equipment event name in equipment event or data set registration on the AI Operator)</p> <p>Attached information 4: Number of equipment events that have a setting error</p> <p>When the value of attached information 3 is 65535 0: Equipment event setting error 1: Setting error in linking with the Time Series Database</p> <p>When the value of attached information 3 is from 0 to 127 1 to 128: Number of equipment events that have a setting error</p>
Precautions/Remarks	None

Event name	PLC System Processing Error		Event code	446F0000 hex	
Meaning	An error was detected in the PLC Function Module.				
Source	PLC Function Module		Source details	FE/MLE	Detection timing Continuously
Error attributes	Level	Minor fault	Recovery	Cycle the power supply.	Log category System
Effects	User program	Continues.	Operation	The Feature Extraction Function stops.	
System-defined variables	Variable	Data type		Name	
	None	---		---	
Cause and correction	Assumed cause		Correction		Prevention
	An error occurred in the software or hardware.		Contact your OMRON representative.		---
Attached information	None				
Precautions/Remarks	None				

Event name	Feature Extraction Service TimeSeries Write Error		Event code	44710000 hex	
Meaning	Writing from the feature extraction service to TimeSeries failed.				
Source	PLC Function Module		Source details	FE/MLE	Detection timing Periodically
Error attributes	Level	Observation	Recovery	—	Log category System
Effects	User program	Continues.	Operation	Not affected.	
System-defined variables	Variable	Data type		Name	
	None	---		---	
Cause and correction	Assumed cause		Correction		Prevention
	The TSDB service was stopped.		Start the TSDB service.		---
	The TSDB service was shut-down.		Cycle the power supply to the AI Controller and start the TSDB service.		
	There is insufficient free space in the internal buffer of the TSDB service.		<ul style="list-style-type: none"> • Increase the set value for the task period of the primary periodic task. • Decrease the number of equipment events. 		
	The SD Memory Card was removed. (for NX-series AI Controllers)		Insert an SD Memory Card.		
	The expanded storage was removed. (for NY-series AI Controllers)		Turn off the power supply to the NY-series AI Controller and mount the expanded storage, and then turn on the power supply.		
Attached information	None				
Precautions/Remarks	None				

Event name	Feature Extraction Setting Changed		Event code	95E30000 hex	
Meaning	The setting of the Feature Extraction Function was updated.				
Source	PLC Function Module		Source details	FE/MLE	Detection timing When downloading
Error attributes	Level	Information	Recovery	---	Log category Access
Effects	User program	Continues.	Operation	Not affected.	
System-defined variables	Variable		Data type		Name
	None		---		---
Cause and correction	Assumed cause		Correction		Prevention
	The setting of the Feature Extraction Function was changed with the AI Operator.		---		---
	The setting of the Feature Extraction Function was changed by the Clear All Memory operation.				
	The setting of the Feature Extraction Function was changed by the download operation.				
The setting of the Feature Extraction Function was changed by the restore operation.					
Attached information	None				
Precautions/Remarks	None				

Event name	Feature Extraction Service Stopped		Event code	95E40000 hex	
Meaning	The Feature Extraction Function entered the idle state.				
Source	PLC Function Module		Source details	FE/MLE	Detection timing At power ON, when downloading, when memory is all cleared, at restore operation
Error attributes	Level	Information	Recovery	---	Log category System
Effects	User program	Continues.	Operation	Not affected.	
System-defined variables	Variable		Data type		Name
	_FE_Status		_eFE_STATUS		Feature Extraction Service Status
Cause and correction	Assumed cause		Correction		Prevention
	The Feature Extraction Function entered the idle state.		---		---
Attached information	None				
Precautions/Remarks	None				

Event name	Feature Extraction Service Started		Event code	95E50000 hex		
Meaning	The Feature Extraction Function entered the running state.					
Source	PLC Function Module	Source details	FE/MLE	Detection timing	When reading the setting of the Feature Extraction Function is completed normally	
Error attributes	Level	Information	Recovery	---	Log category	System
Effects	User program	Continues.	Operation	Not affected.		
System-defined variables	Variable	Data type		Name		
	_FE_Status	_eFE_STATUS		Feature Extraction Service Status		
Cause and correction	Assumed cause	Correction		Prevention		
	The Feature Extraction Function entered the running state.	---		---		
Attached information	None					
Precautions/Remarks	None					

● Machine Learning Function

Event name	Machine Learning Service Setting Error		Event code	35EA0000 hex	
Meaning	There is an error in the machine learning function setting.				
Source	PLC Function Module		Source details	FE/MLE	Detection timing
					At power ON, Controller reset, or when downloading settings
Error attributes	Level	Minor fault	Recovery	Downloading by the AI Operator or Sysmac Studio	Log category
					System
Effects	User program	Continues.	Operation	Not affected.	
System-defined variables	Variable		Data type	Name	
	_MLE_Status		_eMLE_STATUS	Machine Learning Service Status	
Cause and correction	Assumed cause		Correction		Prevention
	There is a variable that is not registered in the Sysmac Studio.		Register the variable from the Sysmac Studio and then download the settings.		Download from the Sysmac Studio first and then from the AI Operator next.
	Power was interrupted while the setting was being downloaded.		Download the setting from the AI Operator (machine learning service setting) or Sysmac Studio (variable setting).		Do not interrupt the power supply during download of the settings, Clear All Memory, or restore operations.
	Power was interrupted during the Clear All Memory operation.				
	Power was interrupted during the restore operation.				
	A format error of the learned data occurred.		Create the learned data again and then download it.		None
An mismatch between the setting and the learned data occurred.					

Attached information	<p>Attached information 1: Classification for identifying the cause of the error</p> <p>01 hex: Setting error 02 hex: Variable setting error 03 hex: Learned data error 04 hex: Inconsistent setting data 05 hex: Non-volatile memory access error</p> <p>Attached information 2: Classification for identifying the cause of the error</p> <p>When the value of attached information 1 is 1 01 hex: Setting error</p> <p>When the value of attached information 1 is 2 01 hex: A variable that is not existed was specified 02 hex: A data type that is not permitted was specified 03 hex: A variable with the Constant attribute was specified for the output frame variable of the machine learning.</p> <p>When the value of attached information 1 is 3 01 hex: The learned data cannot read or does not exist 02 hex: The format of the learned data is not correct</p> <p>When the value of attached information 1 is 4 01 hex: The number of learned data fields and the number of dimensions in the setting file do not match 02 hex: The number of learned data records and the number of records in the setting file do not match</p> <p>Attached information 3: Only when the value of attached information 1 is 1, 2, 3, or 4. Classification for identifying the cause of the error</p> <p>65535: Setting error of the Machine Learning Function 0 to 127: Equipment event number where an error was detected first (ID corresponding to the equipment event name in equipment event or data set registration on the AI Operator)</p> <p>Attached information 4: Only when the value of attached information 3 is from 0 to 127. Number of equipment events that have a setting error</p> <p>1 to 128: Number of equipment events that have a setting error</p>
Precautions/Remarks	None

Event name	PLC System Processing Error		Event code	446E0000 hex	
Meaning	An error was detected in the PLC Function Module.				
Source	PLC Function Module		Source details	FE/MLE	Detection timing Continuously
Error attributes	Level	Minor fault	Recovery	Cycle the power supply.	Log category System
Effects	User program	Continues.	Operation	The Machine Learning Function stops.	
System-defined variables	Variable	Data type		Name	
	None	---		---	
Cause and correction	Assumed cause		Correction		Prevention
	An error occurred in the software or hardware.		Contact your OMRON representative.		---
Attached information	None				
Precautions/Remarks	None				

Event name	Machine Learning Service TimeSeries Write Error		Event code	44700000 hex	
Meaning	Writing from the machine learning service to TimeSeries failed.				
Source	PLC Function Module		Source details	FE/MLE	Detection timing Periodically
Error attributes	Level	Observation	Recovery	---	Log category System
Effects	User program	Continues.	Operation	Not affected.	
System-defined variables	Variable		Data type		Name
	None		---		---
Cause and correction	Assumed cause		Correction		Prevention
	The TSDB service was stopped.		Start the TSDB service.		---
	The TSDB service was shut down.		Cycle the power supply to the AI Controller and start the TSDB service.		
	There is insufficient free space in the internal buffer of the TSDB service.		<ul style="list-style-type: none"> • Increase the set value for the task period of the primary periodic task. • Decrease the number of equipment events. 		
	The SD Memory Card was removed. (for NX-series AI Controllers)		Insert an SD Memory Card.		
	The expanded storage was removed. (for NY-series AI Controllers)		Turn off the power supply to the NY-series AI Controller and mount the expanded storage, and then turn on the power supply.		
Attached information	None				
Precautions/Remarks	None				

Event name	Machine Learning Service Setting Changed		Event code	95E00000 hex	
Meaning	The setting of the Machine Learning Function or the learned data was updated.				
Source	PLC Function Module		Source details	FE/MLE	Detection timing When downloading, when memory is all cleared, at restore operation
Error attributes	Level	Information	Recovery	---	Log category Access
Effects	User program	Continues.	Operation	Not affected.	
System-defined variables	Variable	Data type		Name	
	None	---		---	
Cause and correction	Assumed cause		Correction		Prevention
	The setting of the Machine Learning Function or the learned data was changed with the AI Operator.		---		---
	The setting of the Machine Learning Function was changed by the Clear All Memory operation.				
		The setting of the Machine Learning Function was changed by the restore operation.			
Attached information	None				
Precautions/Remarks	None				

Event name	Machine Learning Service Stopped		Event code	95E10000 hex	
Meaning	The Machine Learning Function entered the idle state.				
Source	PLC Function Module		Source details	FE/MLE	Detection timing At power ON, when downloading, when memory is all cleared, at restore operation
Error attributes	Level	Information	Recovery	---	Log category System
Effects	User program	Continues.	Operation	Not affected.	
System-defined variables	Variable	Data type		Name	
	_MLE_Status	_eMLE_STATUS		Machine Learning Service Status	
Cause and correction	Assumed cause		Correction		Prevention
	The status of the Machine Learning Function entered the reading or error state.		---		---
Attached information	None				
Precautions/Remarks	None				

Event name	Machine Learning Service Started		Event code	95E20000 hex	
Meaning	The Machine Learning Function entered the running state.				
Source	PLC Function Module		Source details	FE/MLE	Detection timing When reading the setting of the Machine Learning Function is completed normally
Error attributes	Level	Information	Recovery	---	Log category System
Effects	User program	Continues.	Operation	Not affected.	
System-defined variables	Variable		Data type		Name
	_MLE_Status		_eMLE_STATUS		Machine Learning Service Status
Cause and correction	Assumed cause		Correction		Prevention
	The status of the Machine Learning Function entered the idle or running state.		---		---
Attached information	None				
Precautions/Remarks	None				

WebAPI Connection Function

Event name	WebAPI Connection Service Setting Error		Event code	35F40000 hex		
Meaning	There is an error in the WebAPI connection service setting.					
Source	PLC Function Module		Source details	WebAPI	Detection timing	At power ON, Controller re-set, or when downloading settings
Error attributes	Level	Minor fault	Recovery	Automatic recovery	Log category	System
Effects	User program	Continues.	Operation	Not affected.		
System-defined variables	Variable	Data type		Name		
	None	---		---		
Cause and correction	Assumed cause		Correction		Prevention	
	Setting error		Identify the error from the attached information, correct the setting, and then download the setting again.		None	
	Power was interrupted while the setting was being downloaded.		Perform the Clear All Memory operation or download the settings.		Do not interrupt the power supply during download of the settings, Clear All Memory, or restore operations.	
	Power was interrupted during the Clear All Memory operation.					
	Power was interrupted during the restore operation.					
Non-volatile memory failed.		Replace the AI Controller.		None		
Attached information	<p>Attached information 1: Error details</p> <ul style="list-style-type: none"> 01 hex: Non-volatile memory access error 02 hex: WebAPI connection service setting is not correct 03 hex: Certificate management setting is not correct 04 hex: File upload setting is not correct <p>Attached Information 2: Only when attached information 1 is 3 or 4</p> <p>Connection ID (01 hex-) (It corresponds to the combo box for selecting a destination in the WebAPI Settings Tab Page on the AI Operator.)</p>					
Precautions/Remarks	None					

Event name	WebAPI Connection Service System Processing Error		Event code	44780000 hex	
Meaning	A fatal error was detected in the WebAPI connection service.				
Source	PLC Function Module		Source details	WebAPI	Detection timing Continuously
Error attributes	Level	Minor fault	Recovery	Cycle the power supply or reset the Controller.	Log category System
Effects	User program	Continues.	Operation	Not affected.	
System-defined variables	Variable	Data type		Name	
	None	---		---	
Cause and correction	Assumed cause		Correction		Prevention
	A fatal error was detected in the WebAPI connection service.		Contact your OMRON representative.		---
Attached information	Attached information 1: System information Attached information 2: System information Attached information 3: System information Attached information 4: System information				
Precautions/Remarks	None				

Event name	Directory Access Failed		Event code	65450000 hex	
Meaning	Accessing to the directory that is stored the transfer file failed.				
Source	PLC Function Module		Source details	WebAPI	Detection timing At file transfer
Error attributes	Level	Minor fault	Recovery	Remove the error and transfer the file	Log category System
Effects	User program	Continues.	Operation	Not affected.	
System-defined variables	Variable	Data type		Name	
	None	---		---	
Cause and correction	Assumed cause		Correction		Prevention
	The directory specified the source file to transfer does not exist.		The directory to specify a transfer file is wrong.		Specify an existing directory in the SD Card inserted to the PLC.
	The SD Memory Card is not inserted (when the SD Memory Card was specified for the transfer source)		Insert an SD Memory Card.		Insert an SD Memory Card.
	The SD Memory Card was removed during the execution of file upload (when the SD Memory Card was specified for the transfer source)		Insert an SD Memory Card.		Do not remove the SD Memory Card while the file upload function is running.
Attached information	Attached information 1: Connection ID (01 hex-) (It corresponds to the combo box for selecting a destination in the WebAPI Settings Tab Page on the AI Operator.)				
Precautions/Remarks	None				

Event name	File Deletion Failed		Event code	65460000 hex		
Meaning	Deleting the file stored in the transfer source directory failed after the file is transferred.					
Source	PLC Function Module		Source details	WebAPI	Detection timing	At file transfer
Error attributes	Level	Minor fault	Recovery	Remove the error and transfer the file	Log category	System
Effects	User program	Continues.	Operation	Not affected.		
System-defined variables	Variable	Data type		Name		
	None	---		---		
Cause and correction	Assumed cause		Correction		Prevention	
	The SD Memory Card is write-protected.		Remove write protection from the SD Memory Card.		Remove write protection from the SD Memory Card.	
Attached information	Attached information 1: Connection ID (01 hex-) (It corresponds to the combo box for selecting a destination in the WebAPI Settings Tab Page on the AI Operator.)					
Precautions/Remarks	None					

Event name	File Upload Failed		Event code	85180000 hex	
Meaning	Uploading a file to the HTTP server failed				
Source	PLC Function Module		Source details	WebAPI	Detection timing At file transfer
Error attributes	Level	Minor fault	Recovery	Eliminate the error and transfer the file	Log category System
Effects	User program	Continues.	Operation	Not affected.	
System-defined variables	Variable	Data type		Name	
	None	---		---	
Cause and correction	Assumed cause		Correction		Prevention
	The specified connection destination URL is incorrect.		Correct the connection destination setting and download it again.		Make sure that the connection destination setting is correct and then download the setting.
	The specified HTTP server stopped the service.		Make sure that the HTTP server operates normally.		Review the operation for HTTP server.
	Equipment settings (Ethernet switch, Proxy server, and DNS server) in the communications path are incorrect.		Correct equipment settings (Ethernet switch, Proxy server, and DNS server) in the communications path.		Make sure that the equipment settings (Ethernet switch, Proxy server, and DNS server) in the communications path are correct and then transfer the file.
	The Ethernet cable connector is disconnected.		Make sure that the connector is inserted correctly.		Insert the connector securely.
	The Ethernet cable is broken.		Replace the Ethernet cable.		None
	An error occurred in the communications path.		Check the communications path to see if there is any problem and take corrective measures.		None
Attached information	<p>Attached information 1: Connection ID (01 hex-) (It corresponds to the combo box for selecting a destination in the WebAPI Settings Tab Page on the AI Operator.)</p> <p>Attached information 2: Reason for the failure</p> <ul style="list-style-type: none"> 01 hex: Server connection failure 02 hex: HTTP response error 03 hex: Invalid certificate (for Https communications only) <p>Attached information 3: Detailed error codes</p> <p>When the value of attached information 2 is 01 hex^{*1}</p> <p>Example:</p> <ul style="list-style-type: none"> 5: Proxy name unresolved 6: Host name unresolved 7: Connection failure (host or proxy) 28: Timeout 35: SSL establishment failed 59: Incorrect version for server encryption communications (TLS) <p>When the value of attached information 2 is 02 hex</p> <p>HTTP status code (HTTP status codes are defined in RFC)</p> <p>When the value of attached information 2 is 03 hex</p> <ul style="list-style-type: none"> 1: The server certificate is invalid or revoked 2: The server certificate is expired 3: The server certificate is a self-signed certificate 4: The root certificate does not exist 				

Precautions/Remarks	This event log is only registered in any of the following cases: <ul style="list-style-type: none"> • The first file transfer failed after powering on the AI Controller • The last file transfer succeeded and the file transfer this time failed
----------------------------	--

*1. You can check the cause of the detailed error code on the AI Operator.

Event name	WebAPI Connection Service Root Certificate Expiration Notice		Event code	65470000 hex		
Meaning	The root certificate of the WebAPI connection service will expire in one month.					
Source	PLC Function Module	Source details	WebAPI	Detection timing	At power ON, Controller reset, when importing a certificate, or periodically (every 24 hours)	
Error attributes	Level	Observation	Recovery	---	Log category	System
Effects	User program	Continues.	Operation	Not affected.		
System-defined variables	Variable	Data type		Name		
	None	---		---		
Cause and correction	Assumed cause	Correction		Prevention		
	It was detected that the root certificate of the WebAPI connection service would expire in one month.	---		---		
Attached information	Attached information 1: Expiration date of the root certificate "YYYY-MM-DD"					
Precautions/Remarks	This event log will not be registered in duplicate until you restart the AI Controller or import the root certificate again.					

Event name	WebAPI Connection Service Started		Event code	95F10000 hex		
Meaning	The WebAPI connection service was started.					
Source	PLC Function Module		Source details	WebAPI	Detection timing	At power ON, Controller reset, or when executing the service start
Error attributes	Level	Information	Recovery	---	Log category	Access
Effects	User program	Continues.	Operation	Not affected.		
System-defined variables	Variable	Data type		Name		
	None	---		---		
Cause and correction	Assumed cause		Correction		Prevention	
	The WebAPI connection service was started.		---		---	
Attached information	<p>Attached information 1: Reason for starting</p> <p>01 hex: Operation from the AI Operator</p> <p>02 hex: Auto-start</p> <p>Attached Information 2: Connection method for only when the value of attached information 1 is 1</p> <p>01 hex: Direct USB connection</p> <p>02 hex: Direct Ethernet connection</p> <p>03 hex: Remote USB connection or Ethernet hub connection</p> <p>Attached Information 3: Only when the value of attached information 2 is 2 or 3</p> <p>Connecting IP address. (Connection through proxy: Proxy IP address)</p>					
Precautions/Remarks	None					

Event name	WebAPI Connection Service Stopped		Event code	95F20000 hex		
Meaning	The WebAPI connection service was stopped.					
Source	PLC Function Module		Source details	WebAPI	Detection timing	When executing the service stop
Error attributes	Level	Information	Recovery	---	Log category	Access
Effects	User program	Continues.	Operation	Not affected.		
System-defined variables	Variable	Data type		Name		
	None	---		---		
Cause and correction	Assumed cause		Correction		Prevention	
	The WebAPI connection service was stopped.		---		---	
Attached information	<p>Attached information 1: Reason for stopping</p> <p>01 hex: Operation from the AI Operator</p> <p>Attached Information 2: Connection method for only when the value of attached information 1 is 1</p> <p>01 hex: Direct USB connection</p> <p>02 hex: Direct Ethernet connection</p> <p>03 hex: Remote USB connection or Ethernet hub connection</p> <p>Attached Information 3: Only when the value of attached information 2 is 2 or 3</p> <p>Connecting IP address. (Connection through proxy: Proxy IP address)</p>					
Precautions/Remarks	None					

Event name	WebAPI Connection Service Setting Updated		Event code	95F30000 hex		
Meaning	The WebAPI connection service setting was updated.					
Source	PLC Function Module		Source details	WebAPI	Detection timing	When the setting is updated
Error attributes	Level	Information	Recovery	---	Log category	Access
Effects	User program	Continues.	Operation	Not affected.		
System-defined variables	Variable	Data type		Name		
	None	---		---		
Cause and correction	Assumed cause		Correction		Prevention	
	The WebAPI connection service setting was updated.		---		---	
Attached information	<p>Attached Information 1: Connection method</p> <p>01 hex: Direct USB connection</p> <p>02 hex: Direct Ethernet connection</p> <p>03 hex: Remote USB connection or Ethernet hub connection</p> <p>Attached Information 2: Only when the value of attached information 1 is 2 or 3</p> <p>Connecting IP address. (Connection through proxy: Proxy IP address)</p>					
Precautions/Remarks	None					

Event name	File Upload Succeeded		Event code	95F40000 hex		
Meaning	The file upload to the HTTP server has succeeded.					
Source	PLC Function Module		Source details	WebAPI	Detection timing	At file transfer
Error attributes	Level	Information	Recovery	---	Log category	System
Effects	User program	Continues.	Operation	Not affected.		
System-defined variables	Variable	Data type		Name		
	None	---		---		
Cause and correction	Assumed cause		Correction		Prevention	
	The file transfer to the HTTP server has succeeded.		---		---	
Attached information	Attached Information 1: Connection ID (01 hex-)					
Precautions/Remarks	<p>This event log is only registered in any of the following cases:</p> <ul style="list-style-type: none"> The first file transfer succeeded after powering on the AI Controller The last file transfer failed and the file transfer this time succeeded 					

Event name	WebAPI Connection Service Certificate Imported		Event code	95F50000 hex	
Meaning	The root certificate of the WebAPI connection service was imported.				
Source	PLC Function Module		Source details	WebAPI	Detection timing When importing a certificate
Error attributes	Level	Information	Recovery	---	Log category Access
Effects	User program	Continues.	Operation	Not affected.	
System-defined variables	Variable		Data type		Name
	None		---		---
Cause and correction	Assumed cause		Correction		Prevention
	The root certificate of the WebAPI connection service was imported.		---		---
Attached information	Attached Information 1: Connection method 01 hex: Direct USB connection 02 hex: Direct Ethernet connection 03 hex: Remote USB connection or Ethernet hub connection Attached Information 2: Only when the value of attached information 1 is 2 or 3 Connecting IP address. (Connection through proxy: Proxy IP address)				
Precautions/Remarks	None				

Time Series Database Instructions

Event name	Insufficient TimeSeries Resources		Event code	54014C0C hex	
Meaning	There is not sufficient resources to execute the Time Series Database Instruction.				
Source	PLC Function Module		Source details	Instruction	Detection timing At instruction execution
Error attributes	Level	Observation	Recovery	---	Log category System
Effects	User program	Continues.	Operation	The relevant instruction will end according to specifications.	
System-defined variables	Variable		Data type		Name
	None		---		---
Cause and correction	Assumed cause		Correction		Prevention
	Insufficient free space in the internal buffer of the TSDB service		Review the number of internal buffers specified in the TSDB service setting.		---
Attached information	None				
Precautions/Remarks	None				

Event name	TSDB Service Control Disabled		Event code	54014C0D hex	
Meaning	While the TSDB service was in the <i>Error</i> or <i>Shutdown</i> state, <i>Start command</i> or <i>Stop command</i> was executed.				
Source	PLC Function Module		Source details	Instruction	Detection timing At instruction execution
Error attributes	Level	Observation	Recovery	---	Log category System
Effects	User program	Continues.	Operation	The relevant instruction will end according to specifications.	
System-defined variables	Variable	Data type		Name	
	None	---		---	
Cause and correction	Assumed cause		Correction		Prevention
	The relevant instruction was executed while the TSDB service was shutting down.		Cycle the power supply to the AI Controller, and then execute the relevant instruction.		Write the user program so that the relevant instruction is not executed while the TSDB service is shutting down.
The relevant instruction was executed while the TSDB service was in the error state.		Update the setting or execute the Clear All Memory operation to set the AI Controller to the factory state.		Write the user program so that the relevant instruction is not executed while the TSDB service is in the error state.	
Attached information	None				
Precautions/Remarks	None				

9

AI Predictive Maintenance Library

This section describes the overview and features of the AI Predictive Maintenance Library.

9-1	Overview of AI Predictive Maintenance Library	9-2
9-2	Features of AI Predictive Maintenance Library	9-3

9-1 Overview of AI Predictive Maintenance Library

The AI Predictive Maintenance Library is one of the function components of the Sysmac Library software that allows you to use the AI functions of the AI Controller.

The AI Predictive Maintenance Library consists of libraries containing the function blocks (FB, hereinafter) for each mechanism (devices and components) used.

When the control and status data of the running mechanism is passed to the FBs, the outlier detection of the mechanism can be performed with the Feature Value/Machine Learning Function of the AI Controller.

The AI Predictive Maintenance Library allows you to perform predictive maintenance easily with the AI functions.

9-2 Features of AI Predictive Maintenance Library

The AI Predictive Maintenance Library has the following features.

Simplified Preparation Processes for Using the AI Functions

The AI Predictive Maintenance Library does not require event definitions for the mechanisms for which predictive maintenance is performed.

Therefore, you can realize to perform the advanced AI-based predictive maintenance even without special knowledge

Selection of Components Used for Typical Mechanisms

The AI Predictive Maintenance Library offers a selection of software function components that can be used for typical mechanisms, such as cylinders and belt conveyors.

The AI functions can be used for multiple mechanisms.

Inherits the Sysmac Library Concept

The AI Predictive Maintenance Library inherits the conventional "Sysmac Library" concept.

This means that you can directly apply the conventional usage of "Sysmac Library", so that you can use AI functions with little additional learning.

For details on the AI Predictive Maintenance Library, refer to the *Sysmac Library AI Predictive Maintenance Library User's Manual (Cat. No. W610)*.



Appendices

This section describes the supplemental information for the body of this manual, such as the detailed specifications of the AI Controllers, specifications for individual system-defined Variables, and the CSV format specifications.

A-1	Specifications	A-2
A-1-1	Specifications Unique to the AI Controllers	A-2
A-1-2	Common Specifications with Standard Models	A-5
A-2	List of System-defined Variables	A-6
A-2-1	Common Variables.....	A-6
A-2-2	Time Series Database Function.....	A-8
A-2-3	Feature Value/Machine Learning Function	A-10
A-2-4	WebAPI Function	A-13
A-3	Specifications for Individual System-defined Variables	A-14
A-3-1	System-defined Variables for the Overall AI Controller (No Category)	A-14
A-3-2	AI Function Modules, Category Name: <code>_AIC</code>	A-16
A-3-3	AI Function Modules, Category Name: <code>_TSDB</code>	A-17
A-3-4	AI Function Modules, Category Name: <code>_FE</code>	A-23
A-3-5	AI Function Modules, Category Name: <code>_MLE</code>	A-24
A-3-6	AI Function Modules, Category Name: <code>_WAC</code>	A-26
A-4	Processing in the Data Collection, Data Analysis, and Data Utilization Phases	A-28
A-4-1	Data Collection Phase	A-28
A-4-2	Data Analysis Phase.....	A-29
A-4-3	Data Utilization Phase	A-29
A-5	CSV File Format	A-32
A-5-1	Variable Data File (RAW-***.csv)	A-32
A-5-2	Analysis Data File (ANL-***.csv).....	A-33
A-5-3	Feature Value File (FTR-***.csv)	A-34
A-5-4	Equipment Event Monitoring Result File (AIS-***.csv).....	A-35
A-6	Version Information	A-38
A-6-1	Version Information for NX-series AI Controllers	A-38
A-6-2	Version Information for NY-series AI Controllers	A-38
A-6-3	Specifications When Not Using the Sysmac Studio Version That Corresponds to the Unit Version of the AI Controller	A-38

A-1 Specifications

This section describes the specifications of the AI Controller.

The AI Controllers refer to the standard CPU Units without the AI functions or the IPC Machine Controllers that are equipped with the AI functions. Thus, the AI Controller specifications are classified into those unique to the AI Controllers and those common to the standard CPU Units or the IPC Machine Controllers. For the specifications that are unique to the AI Controllers, refer to *A-1-1 Specifications Unique to the AI Controllers* on page A-2. For the specifications that are common to the standard CPU Units or the IPC Machine Controllers, refer to *A-1-2 Common Specifications with Standard Models* on page A-5.

A-1-1 Specifications Unique to the AI Controllers

This section describes the AI Controller specifications that are unique to the AI Controllers.

Function Specifications of AI Functions

Refer to the following sections for each function specification of the AI functions.

- Time Series Database Function
Section 2 *Time Series Database Function* on page 2-1
- Feature Value/Machine Learning Function
Section 3 *Feature Value/Machine Learning Function* on page 3-1
- WebAPI Connection Function
Section 4 *WebAPI Connection Function* on page 4-1

SD Memory Card Specifications (NX701-Z□□□ Only)

This section describes the specifications of the SD Memory Cards used in the NX-series AI Controller.

An SD Memory Card is already inserted into the NX-series AI Controller in the factory default state.

Model	Card type	Capacity [GB]	Format	Number of overwrites	Weight
HMC-SD1A1*1	SDHC Card	16	FAT32	100,000	2 g max.

*1. Always use the HMC-SD1A1 SD Memory Card.



Additional Information

Write Protection Key

You will not be able to write to the SD Memory Card if the key is set to the LOCK position. Use this setting to prevent overwriting.

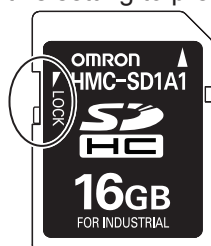

Memory Specifications (NY5□2-Z□□□ Only)

The following table shows the memory specifications for the NY-series AI Controller.

Item		Specification
Total memory size / Memory size for Windows		16 GB/12.8 GB (for Windows 64-bit version)
Memory type		DDR3L
Package memory format		SO-DIMM
Serial Presence Detect (SPD)	Speed grade	1.600 Mbps
	CAS latency	CL11



Additional Information

Small Outline Dual In-Line Memory Modules (SO-DIMM) cannot be added or replaced by users.

Drive Bay Component Specifications (NY5□2-Z□□□ Only)

The drive bays of the NY-series AI Controllers support 2.5-inch Solid State Drive (SSD).

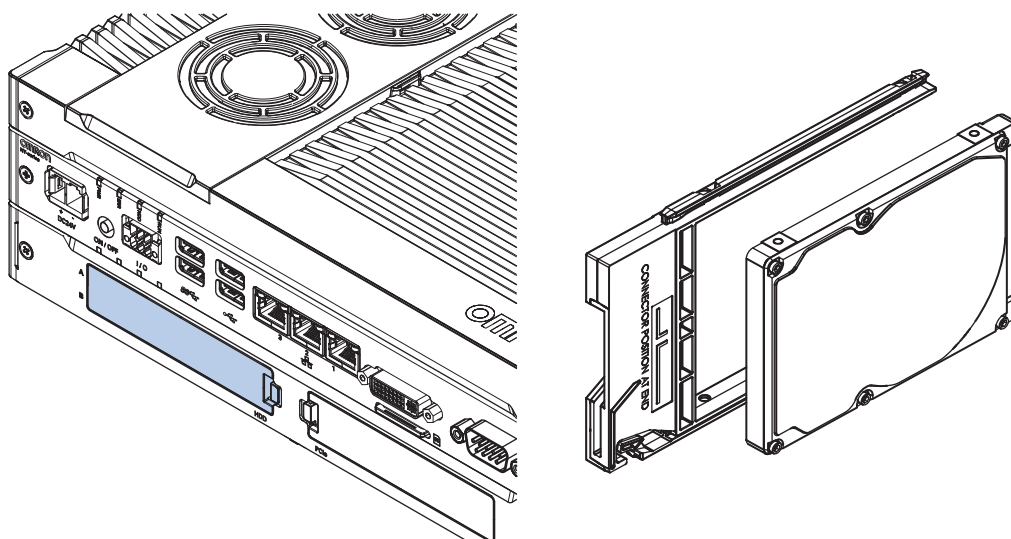

A storage is inserted into both of the drive bays of the NY-series AI Controller in the factory default state. The following table shows the specifications of the drive bay components for the NY-series AI Controllers.

Drive bay	Inserted storage type	Storage (SSD) format	Description
A	Expanded storage	NY000-AS06	It is designed for the Machine Automation Control Software. It cannot be accessed from the Windows operating systems. Drive Bay A is a bay for a connector.
B	Main storage	NY000-AS04	It is designed for the Windows operating systems. It cannot be accessed from the Machine Automation Control Software. Drive Bay B is a bay located on the display panel (for Panel PCs) or a bay located on the exterior side (for Box PCs).



Precautions for Correct Use

Make sure to insert a main storage for the operating systems to the correct drive bay. If you insert it into a wrong drive bay, the AI Controller may not start.

SSD Specifications (NY5□2-Z□□□ Only)

The following table shows the SSD specifications for the NY-series AI Controllers.

Item	Model specification	
Model	NY000-AS04* ¹	NY000-AS06* ²
Capacity	128 GB	
Type	iMLC	pSLC
Details	Innodisk: DES25-A28M41BC1DC	Innodisk: DHS25-A28M41BC1DC
S.M.A.R.T. supported	Yes	
Interface	Serial ATA 3.1	
Sustained read speed	530 MB/s max.	530 MB/s max.
Sustained write speed	210 MB/s max.	380 MB/s max.
Operating temperature	0 to 70°C* ³	
Operating humidity	10% to 95%RH (with no condensation)* ³	
Storage temperature	-55 to 95°C* ³	
Storage humidity	10% to 95%RH (with no condensation)* ³	
Life	374 TB	2500 TB

- *1. It is a dedicated storage device to be inserted into Drive Bay B of an NY5□2-Z□□□ Controller and is used as the main storage. Do not use it for any other purpose.
- *2. It is a dedicated storage device to be inserted into Drive A of an NY5□2-Z□□□ Controller and is used as the expanded storage. Do not use it for any other purpose.
- *3. For the overall specifications of the NY-series AI Controllers, refer to *A-1-2 Common Specifications with Standard Models* on page A-5.

Installer for the AI Controller Software (NY5□2-Z□□□ Only)

An installer used to install the AI Controller Software that is called the AI Viewer and the AI Operator into Windows is saved in the NY-series AI Controllers. The installer is located in D:\OMRON-NY\Installers\AI_Controller_Standard_Software.

When you install the AI Viewer and the AI Operator, open the above storage folder with Windows Explorer or similar applications and double-click the setup.exe file. For details on the installation procedure and specifications of the installed AI Controller Software, refer to the *AI Controller Standard Software Operation Manual (Cat. No. W611)*.

A-1-2 Common Specifications with Standard Models

The specifications of the AI Controller other than the specifications described in *A-1-1 Specifications Unique to the AI Controllers* on page A-2 are in common with those of standard CPU Units or IPC Machine Controllers without the AI functions. Refer to the corresponding specifications for each AI Controller model according to the table below.

AI Controller model	Corresponding standard model
NX701-Z700	NX701-1700
NX701-Z600	NX701-1600
NY532-Z500	NY532-1500
NY532-Z400	NY532-1400
NY532-Z300	NY532-1300
NY512-Z500	NY512-1500
NY512-Z400	NY512-1400
NY512-Z300	NY512-1300

General Specifications

Refer to the hardware user's manual for general specifications.

- NX-series AI Controller:
NX-series CPU Unit Hardware User's Manual (Cat. No. W535)
- NY-series AI Controller (NY532-Z□□□):
NY-series Industrial Panel PC Hardware User's Manual (Cat. No. W557)
- NY-series AI Controller (NY512-Z□□□):
NY-series Industrial Box PC Hardware User's Manual (Cat. No. W556)

Performance Specifications

Refer to the following manual for the performance specifications.

- NX-series AI Controller:
NJ/NX-series CPU Unit Software User's Manual (Cat. No. W501)
- NY-series AI Controller:
NY-series Industrial Panel PC / Industrial Box PC Software User's Manual (Cat. No. W558)

Function Specifications

Function Specifications other than AI functions are same as those for the standard CPU Units or for the IPC Machine Controllers without the AI functions. Refer to the following manual.

- NX-series AI Controller:
NJ/NX-series CPU Unit Software User's Manual (Cat. No. W501)
- NY-series AI Controller:
NY-series Industrial Panel PC / Industrial Box PC Software User's Manual (Cat. No. W558)

A-2 List of System-defined Variables

This section describes the system-defined variables that are unique to the AI Controllers.

System-defined variables except for the AI Controller are used in the same series. For more information on the NX-series Controllers, refer to the *NJ/NX-series CPU Unit Software User's Manual (Cat. No. W501)*. For more information on the NY-series Controllers, refer to the *NY-series Industrial Panel PC / Industrial Box PC Software User's Manual (Cat. No. W558)*.

A-2-1 Common Variables

Variable name	Meaning	Function	Data type	Range of values
_AIC_Version	AIC Version	Shows the version of the AI Controller package. The integer part of the version is stored in the element number 0. The fractional part of the version is stored in the element number 1. Example) If the unit version is 1.10, 1 is stored in element number 0 and 10 is stored in element number 1.	ARRAY[0..1] OF USINT	0 to 99
_Card1Capacity	SD Memory Card Storage Capacity	Specifies the total capacity of the inserted SD Memory Card (NX-series) or that of the Virtual SD Memory Card (NY-series). The unit is MiB. (1 MiB = 1,048,576 Byte) The value is updated every 60 seconds. If the SD PWR indicator is not lit, such as when an SD Memory Card is not inserted, the value is "0" (NX-series). If the Virtual SD Memory Card is disabled, the value is "0" (NY-series).	UDINT	Depends on the data type.

Variable name	Meaning	Function	Data type	Range of values
_Card1Used	SD Memory Card Storage Usage	Specifies the usage of the inserted SD Memory Card (NX-series) or that of the Virtual SD Memory Card (NY-series). The unit is MiB. (1 MiB = 1,048,576 Byte) The value is updated every 60 seconds. If the SD PWR indicator is not lit, such as when an SD Memory Card is not inserted, the value is "0" (NX-series). If the Virtual SD Memory Card is disabled, the value is "0" (NY-series).	UDINT	Depends on the data type.
_Card1RestoreCmdTargetAicMLD*1	AI Machine Learning Model Transfer Flag	TRUE when you specify the AI machine learning model as the transfer target for the restore operation with the system-defined variable of the SD Memory Card backup function. Always set this variable to TRUE for the restore with the system-defined variable.	BOOL	TRUE or FALSE
_ExtendedStorage1Ready	Extended Storage1 Ready Flag	Specifies the usage status of the storage to which CSV files are exported from the Time Series Database Function. TRUE: Available FALSE: Not available	BOOL	TRUE or FALSE
_ExtendedStorage1Capacity	Extended Storage1 Capacity	Specifies the total capacity of the storage to which CSV files are exported from the Time Series Database Function. The unit is MiB. (1 MiB = 1,048,576 Byte)	UDINT	Depends on the data type.
_ExtendedStorage1Used	Extended Storage1 Usage	Specifies the usage of the storage to which CSV files are exported from the Time Series Database Function. The unit is MiB. (1 MiB = 1,048,576 Byte) The value is updated periodically.	UDINT	Depends on the data type.
_ExtendedStorage2Ready*2	Extended Storage2 Ready Flag	Specifies the usage status of the expanded storage that is mounted to the drive bay A. TRUE: Available FALSE: Not available	BOOL	TRUE or FALSE
_ExtendedStorage2Capacity*2	Extended Storage2 Capacity	Specifies the total capacity of the expanded storage that is mounted to the drive bay A. The unit is MiB. (1 MiB = 1,048,576 Byte)	UDINT	Depends on the data type.

Variable name	Meaning	Function	Data type	Range of values
_ExtendedStorage2Used*2	Extended Storage2 Usage	Specifies the usage of the expanded storage that is mounted to the drive bay A. The unit is MiB. (1 MiB = 1,048,576 Byte) The value is updated periodically.	UDINT	Depends on the data type.

*1. This can be used for the NX-series only.

*2. This can be used for the NY-series only.

A-2-2 Time Series Database Function

Variable name	Meaning	Function	Data type	Range of values
Member name				
_TSDB_Status	TSDB Service Status	Shows the operation status of the TSDB service.	_sTSDB_STATUS	
Run	Running	TRUE when the TSDB service is running.	BOOL	TRUE or FALSE
Idle	Idle	TRUE when the TSDB service is idle.	BOOL	TRUE or FALSE
Error	Error	TRUE when the TSDB service is stopped by an error.	BOOL	TRUE or FALSE
Shutdown	Shutdown	TRUE when the TSDB service has shut down.	BOOL	TRUE or FALSE
_TSDB_ShutdownCmd	TSDB Service Shutdown Command	TRUE when you shut down the TSDB service.	BOOL	TRUE or FALSE
_TSDB_TSName	TimeSeries Name	Specifies a TimeSeries name.	ARRAY[0..31] OF STRING(64)*1	Depends on the data type.
_TSDB_TSSta	TimeSeries Status	Shows the TimeSeries status.	ARRAY[0..31] OF _sTSDB_TSSTA*1	

Variable name		Meaning	Function	Data type	Range of values
Member name					
IsCreate	TimeSeries Creation Flag	TRUE when the TimeSeries has already been created.	BOOL	TRUE or FALSE	
IsOpen	TimeSeries Open Status Flag	TRUE when the TimeSeries is already opened.	BOOL	TRUE or FALSE	
IsSmpl	Sampling Execution Flag	TRUE when sampling is being executed.	BOOL	TRUE or FALSE	
IsExpt	Export Execution Flag	TRUE when export is being executed.	BOOL	TRUE or FALSE	
IsExptRec	Export Record Existence Flag	TRUE when export is being executed and the record to be exported exists.	BOOL	TRUE or FALSE	
OpenErr	Sampling Mode Open Error Flag	TRUE when an error occurred during TimeSeries open processing.	BOOL	TRUE or FALSE	
SmplErr	Sampling Error Flag	TRUE when there is an error in the sampling.	BOOL	TRUE or FALSE	
ExptErr	Export Error Flag	TRUE when there is an error in the export.	BOOL	TRUE or FALSE	
ErrCode	Error Cause Code	Shows the cause of the error occurred in TimeSeries. Refer to <i>A-3-3 AI Function Modules, Category Name: _TSDB</i> on page A-17 for the meaning of the values.	WORD	16#0000 to 16#FFFF	
_TSDB_SmplStartCmd	Sampling Start Command	TRUE when you start sampling of the TimeSeries.	ARRAY[0..31] OF BOOL ^{*1*2}	TRUE or FALSE	
_TSDB_SmplStopCmd	Sampling Stop Command	TRUE when you stop sampling of the TimeSeries.	ARRAY[0..31] OF BOOL ^{*1*2}	TRUE or FALSE	
_TSDB_ExptStartCmd	Export Start Command	TRUE when you start export of the TimeSeries.	ARRAY[0..31] OF BOOL ^{*1}	TRUE or FALSE	
_TSDB_ExptStopCmd	Export Stop Command	TRUE when you stop export of the TimeSeries.	ARRAY[0..31] OF BOOL ^{*1}	TRUE or FALSE	
_TSDB_ClearCmd	TimeSeries Clear Command	TRUE when you clear data in the TimeSeries.	ARRAY[0..31] OF BOOL ^{*1}	TRUE or FALSE	
_TSDB_SmplMode	TimeSeries Sampling Mode	Shows the mode of the defined TimeSeries. 0: Not used 1: Using	ARRAY[0..31] OF UINT ^{*1}	0 or 1	
_TSDB_CreateCmd	TimeSeries Creation Command	Issue a command to recreate a TimeSeries. While the TSDB service status is idle, this flag can be switched from FALSE to TRUE. You can also recreate a TimeSeries by opening the Monitor/Operation screen on AI Operator and selecting TimeSeries , and then pressing the Reconstruct Button	ARRAY[0..31] OF BOOL ^{*1}	TRUE or FALSE	

Variable name	Meaning	Function	Data type	Range of values
Member name				
_TSDB_Version	TSDB Service Version	Shows the version of the TSDB service. The integer part of the version is stored in the element number 0. The fractional part of the version is stored in the element number 1. Example) If the TSDB function version is 1.10, 1 is stored in element number 0 and 10 is stored in element number 1.	ARRAY[0..1] OF USINT	0 to 99

- *1. The array element numbers correspond to the following:
0: RAW_DATA, 1: ANL_DATA, 2: FTR_DATA, 3: AIS_DATA, 4 to 31: Reserved
- *2. Do not write values to the element [2] and [3]. Element [2] indicates the feature value. Element [3] indicates the equipment event monitoring result. The Feature Value/Machine Learning Function starts and stops the processes.

A-2-3 Feature Value/Machine Learning Function

Feature Extraction Function

Variable name	Meaning	Function	Data type	Range of values
_FE_Status	Feature Extraction Service Status	Shows the status of the feature extraction service. _FE_STATUS_INITIALIZE: Initializing _FE_STATUS_LOAD: Loading _FE_STATUS_IDLE: Idle _FE_STATUS_RUN: Running _FE_STATUS_PARAMETER_ERROR: Error	_eFE_STATUS	Depends on the data type.
_FE_Result	Feature Value	Shows the extracted feature value.	ARRAY[0..127, 0..15] OF LREAL*1	Depends on the data type.
_FE_Enable	Feature Extraction Service Enable Command	Send a command to change the status of the feature extraction service. TRUE when you change the status to Running. When the AI Controller is in the RUN mode, the status changes to Running. FALSE when you change the status to Idle.	BOOL	TRUE or FALSE

- *1. The first dimension and the second dimension in the array correspond to the following on the AI Operator screen respectively:
 - The first dimension: IDs displayed in the equipment event list.
 - The second dimension: Feature Values displayed in the adopted variables and feature values.
 In the following screen example, _FE_Result[2,0] is maximum, _FE_Result[2,1], and _FE_Result[2,2] is the standard deviation for the feature values of equipment event *Equip. Event 3*.

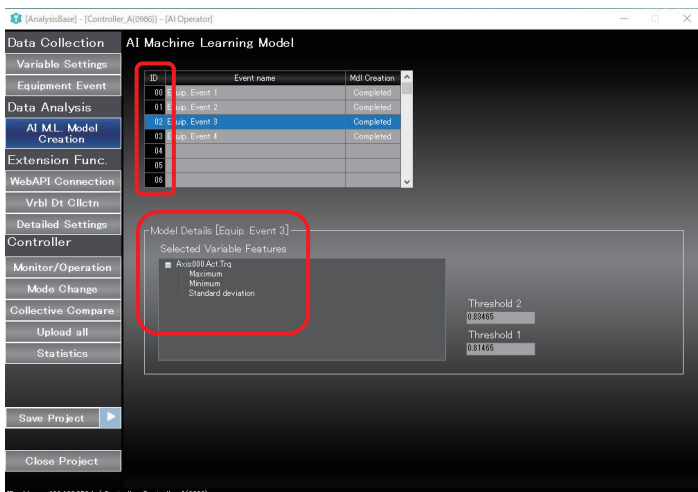

Machine Learning Function

Variable name	Meaning	Function	Data type	Range of values
Member name				
_MLE_Status	Machine Learning Service Status	Shows the status of the machine learning service. _MLE_STATUS_INITIALIZE: Initializing _MLE_STATUS_LOAD: Loading _MLE_STATUS_IDLE: Idle _MLE_STATUS_RUN: Running _MLE_STATUS_PARAMETER_ERROR: Error	_eMLE_STATUS	Depends on the data type.
_MLE_Result	Equipment Event Monitoring Result	Shows the equipment event monitoring result.	ARRAY[0..127] OF _sMLE_RESULT*1	
Level	Level Judgment Result	Shows the level judgment result. -1: Judgment failed 0: Initial value (not tested) 1: Normal 2: Alarm level 1 3: Alarm level 2	INT	-1 to 3
Score	Equipment Event Monitoring Score	Shows the equipment event monitoring score. Judgment failed: -∞	LREAL	Depends on the data type.
_MLE_Statistics	Statistics on Equipment Event Monitoring Result	Shows the judgment statistic of the machine learning service. When the machine learning service enters the Idle state, the value of each member is 0.	ARRAY[0..127] OF _sMLE_STATISTICS*1	

Variable name	Member name	Meaning	Function	Data type	Range of values
Level2Count	Number of Level 2 Judgment Results	Shows the number of results judged as Alarm level 1.	UDINT	Depends on the data type.	
Level3Count	Number of Level 3 Judgment Results	Shows the number of results judged as Alarm level 2.	UDINT	Depends on the data type.	
ErrorFrameCount	Number of Frames That Failed the Judgment	Shows the number of frames of which feature extraction resulted in an error or judgment failed.	UDINT	Depends on the data type.	
ErrorID	Cause of the Last Failed Judgment for the Frame	Shows the cause of the last failed judgment for the frame. 1: Input data is invalid (Feature value calculation result is $-\infty$, $+\infty$, or not a number) 2: Frame omission due to exceeded judgment	DWORD	1 to 2	
_MLE_Enable	Machine Learning Service Enable Command	Send a command to change the status of the machine learning service. TRUE when you change the status to Running. FALSE when you change the status to Idle.	BOOL	TRUE or FALSE	

*1. Array element numbers indicate the ID of the equipment event. They correspond to the IDs of the equipment event list on the AI Operator.

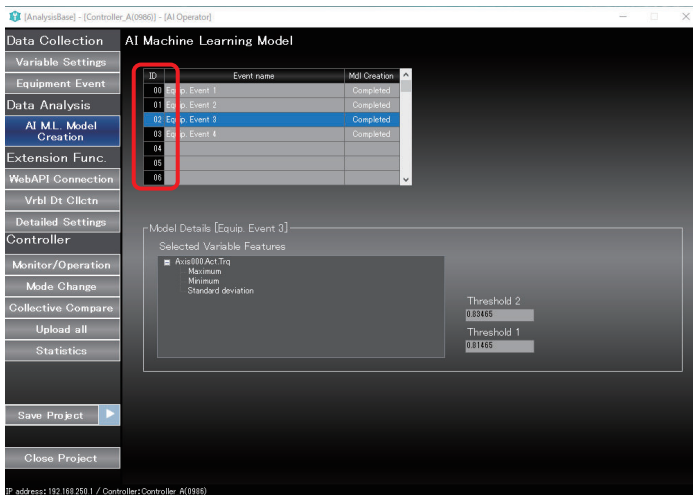

A-2-4 WebAPI Function

Variable name	Meaning	Function	Data type	Range of values
_WAC_Version	WebAPI Version	Shows the version of the WebAPI package. The integer part of the version is stored in the element number 0. The fractional part of the version is stored in the element number 1. Example) If the WebAPI version is 1.10, 1 is stored in the element number 0 and 10 is stored in the element number 1.	ARRAY[0..1] OF USINT	0 to 99

A-3 Specifications for Individual System-defined Variables

The specifications for each system-defined variable are given as described below.

Variable name	This is the system-defined variable name. The prefix gives the category name.		Member name (for structures)	The member names are given for structure only.
Meaning	This is the meaning of the variable.		Global/local	Global: Global variable Local: Local variable
Function	The function of the variable is described.			
Data type	The data type of the variable is given.		Range of values	The range of values that the variable can take is given.
R/W access	R: Read only, RW: Read/write	Retained	The Retain attribute of the variable is given.	Network Publish The Network Publish attribute of the variable is given.
Usage in user program	Whether you can use the variable directly in the user program is specified.	Related instructions	The instructions that are related to the variable are given. If <i>Usage in user program</i> is not allowed, the instructions to access the variable are given.	

A-3-1 System-defined Variables for the Overall AI Controller (No Category)

● Functional Classification: Storage

Variable name	_Card1Capacity			
Meaning	SD Memory Card Storage Capacity	Global/local	Global	
Function	Specifies the total capacity of the inserted SD Memory Card (NX-series) or that of the Virtual SD Memory Card (NY-series). The unit is MiB. (1 MiB = 1,048,576 Byte) The value is updated every 60 seconds. If the SD PWR indicator is not lit, such as when an SD Memory Card is not inserted, the value is "0" (NX-series). If the Virtual SD Memory Card is disabled, the value is "0" (NY-series).			
Data type	UDINT	Range of values	Depends on the data type.	
R/W access	R	Retained	Not retained.	Network Publish Published.
Usage in user program	Possible.	Related instructions	---	

Variable name	_Card1Used				
Meaning	SD Memory Card Storage Usage	Global/local		Global	
Function	Specifies the usage of the inserted SD Memory Card (NX-series) or that of the Virtual SD Memory Card (NY-series). The unit is MiB. (1 MiB = 1,048,576 Byte) The value is updated every 60 seconds. If the SD PWR indicator is not lit, such as when an SD Memory Card is not inserted, the value is "0" (NX-series). If the Virtual SD Memory Card is disabled, the value is "0" (NY-series).				
Data type	UDINT	Range of values		Depends on the data type.	
R/W access	R	Retained	Not retained.	Network Publish	Published.
Usage in user program	Possible.	Related instructions	---		

Variable name	_Card1RestoreCmdTargetAicMLD*1				
Meaning	AI Machine Learning Model Transfer Flag	Global/local		Global	
Function	TRUE when you specify the AI machine learning model as the transfer target for the restore operation with the system-defined variable. Always set this variable to TRUE for the restore with the system-defined variable.				
Data type	BOOL	Range of values		TRUE or FALSE	
R/W access	RW	Retained	Retain	Network Publish	Published.
Usage in user program	Possible.	Related instructions	---		

*1. This can be used for the NX-series only.

Variable name	_ExtendedStorage1Ready				
Meaning	Extended Storage1 Ready Flag	Global/local		Global	
Function	Specifies the usage status of the storage to which CSV files are exported from the Time Series Database Function. TRUE: Available FALSE: Not available				
Data type	BOOL	Range of values		TRUE or FALSE	
R/W access	R	Retained	Not retained.	Network Publish	Published.
Usage in user program	Possible.	Related instructions	---		

Variable name	_ExtendedStorage1Capacity				
Meaning	Extended Storage1 Capacity	Global/local		Global	
Function	Specifies the total capacity of the storage to which CSV files are exported from the Time Series Database Function. The unit is MiB. (1 MiB = 1,048,576 Byte)				
Data type	UDINT	Range of values		Depends on the data type.	
R/W access	R	Retained	Not retained.	Network Publish	Published.
Usage in user program	Possible.	Related instructions	---		

Variable name	_ExtendedStorage1Used				
Meaning	Extended Storage1 Usage			Global/local	Global
Function	Specifies the usage of the storage to which CSV files are exported from the Time Series Database Function. The unit is MiB. (1 MiB = 1,048,576 Byte) The value is updated periodically.				
Data type	UDINT			Range of values	Depends on the data type.
R/W access	R	Retained	Not retained.	Network Publish	Published.
Usage in user program	Possible.	Related instructions	---		

Variable name	_ExtendedStorage2Ready*1				
Meaning	Extended Storage2 Ready Flag			Global/local	Global
Function	Specifies the usage status of the expanded storage that is mounted to the drive bay A. TRUE: Available FALSE: Not available				
Data type	BOOL			Range of values	TRUE or FALSE
R/W access	R	Retained	Not retained.	Network Publish	Published.
Usage in user program	Possible.	Related instructions	---		

*1. This can be used for the NY-series only.

Variable name	_ExtendedStorage2Capacity*1				
Meaning	Extended Storage2 Capacity			Global/local	Global
Function	Specifies the total capacity of the expanded storage that is mounted to the drive bay A. The unit is MiB. (1 MiB = 1,048,576 Byte)				
Data type	UDINT			Range of values	Depends on the data type.
R/W access	R	Retained	Not retained.	Network Publish	Published.
Usage in user program	Possible.	Related instructions	---		

*1. This can be used for the NY-series only.

Variable name	_ExtendedStorage2Used*1				
Meaning	Extended Storage2 Usage			Global/local	Global
Function	Specifies the usage of the expanded storage that is mounted to the drive bay A. The unit is MiB. (1 MiB = 1,048,576 Byte) The value is updated periodically.				
Data type	UDINT			Range of values	Depends on the data type.
R/W access	R	Retained	Not retained.	Network Publish	Published.
Usage in user program	Possible.	Related instructions	---		

*1. This can be used for the NY-series only.

A-3-2 AI Function Modules, Category Name: _AIC

● **Functional Classification: Version**

Variable name	_AIC_Version				
Meaning	AIC Version	Global/local		Global	
Function	Shows the version of the AI Controller package. The integer part of the version is stored in the element number 0. The fractional part of the version is stored in the element number 1. Example) If the unit version is 1.10, 1 is stored in element number 0 and 10 is stored in element number 1.				
Data type	ARRAY [0..1] OF USINT	Range of values		0 to 99	
R/W access	R	Retained	Not retained.	Network Publish	Published.
Usage in user program	Possible.	Related instructions	---		

A-3-3 AI Function Modules, Category Name: _TSDB

● **Functional Classification: Time Series Database Function**

Variable name	_TSDB_Version				
Meaning	TSDB Service Version	Global/local		Global	
Function	Shows the version of the TSDB service. The integer part of the version is stored in the element number 0. The fractional part of the version is stored in the element number 1. Example) If the TSDB function version is 1.10, 1 is stored in element number 0 and 10 is stored in element number 1.				
Data type	ARRAY [0..1] OF USINT	Range of values		0 to 99	
R/W access	R	Retained	Not retained.	Network Publish	Published.
Usage in user program	Possible.	Related instructions	---		

Variable name	_TSDB_Status		Member name	.Run	
Meaning	Running		Global/local	Global	
Function	TRUE when the TSDB service is in the running state.				
Data type	Structure: _sTSDB_STATUS, Member: BOOL		Range of values	TRUE or FALSE	
R/W access	R	Retained	Not retained.	Network Publish	Published.
Usage in user program	Possible.	Related instructions	<ul style="list-style-type: none"> TimeSeries_ControlService 		

Variable name	_TSDB_Status		Member name	.Idle	
Meaning	Idle		Global/local	Global	
Function	TRUE when the TSDB service is in the idle state.				
Data type	Structure: _sTSDB_STATUS, Member: BOOL		Range of values	TRUE or FALSE	
R/W access	R	Retained	Not retained.	Network Publish	Published.
Usage in user program	Possible.	Related instructions	<ul style="list-style-type: none"> TimeSeries_ControlService 		

Variable name	_TSDB_Status			Member name	.Error
Meaning	Error			Global/local	Global
Function	TRUE when the TSDB service is in the error state.				
Data type	Structure: _sTSDB_STATUS, Member: BOOL			Range of values	TRUE or FALSE
R/W access	R	Retained	Not retained.	Network Publish	Published.
Usage in user program	Possible.	Related instructions	• TimeSeries_ControlService		

Variable name	_TSDB_Status			Member name	.Shutdown
Meaning	Shutdown			Global/local	Global
Function	TRUE when the TSDB service is in the shutdown state.				
Data type	Structure: _sTSDB_STATUS, Member: BOOL			Range of values	TRUE or FALSE
R/W access	R	Retained	Not retained.	Network Publish	Published.
Usage in user program	Possible.	Related instructions	• TimeSeries_ControlService		

Variable name	_TSDB_ShutdownCmd				
Meaning	TSDB Service Shutdown Command			Global/local	Global
Function	TRUE when you shut down the TSDB service.				
Data type	BOOL			Range of values	TRUE or FALSE
R/W access	RW	Retained	Not retained.	Network Publish	Published.
Usage in user program	Possible.	Related instructions	---		

Variable name	_TSDB_TSName				
Meaning	TimeSeries Name			Global/local	Global
Function	Stores a TimeSeries name. The array element numbers correspond to the following: 0: RAW_DATA, 1: ANL_DATA, 2: FTR_DATA, 3: AIS_DATA, 4 to 31: Reserved				
Data type	ARRAY [0..31] OF STRING(64)			Range of values	Depends on the data type.
R/W access	R	Retained	Not retained.	Network Publish	Published.
Usage in user program	Possible.	Related instructions	---		

Variable name	_TSDB_TSSSta			Member name	.IsCreate
Meaning	TimeSeries Creation Flag			Global/local	Global
Function	TRUE when the TimeSeries has already been created. The array element numbers correspond to the following: 0: RAW_DATA, 1: ANL_DATA, 2: FTR_DATA, 3: AIS_DATA, 4 to 31: Reserved				
Data type	Structure: ARRAY [0..31] OF _sTSDB_TSSTA, Member: BOOL			Range of values	TRUE or FALSE
R/W access	R	Retained	Not retained.	Network Publish	Published.
Usage in user program	Possible.	Related instructions	---		

Variable name	_TSDB_TSSta			Member name	.IsOpen
Meaning	TimeSeries Open Status Flag			Global/local	Global
Function	TRUE when the TimeSeries is already opened. The array element numbers correspond to the following: 0: RAW_DATA, 1: ANL_DATA, 2: FTR_DATA, 3: AIS_DATA, 4 to 31: Reserved				
Data type	Structure: ARRAY [0..31] OF _sTSDB_TSSTA, Member: BOOL			Range of values	TRUE or FALSE
R/W access	R	Retained	Not retained.	Network Publish	Published.
Usage in user program	Possible.	Related instructions	---		

Variable name	_TSDB_TSSta			Member name	.IsSmpl
Meaning	Sampling Execution Flag			Global/local	Global
Function	TRUE when sampling is being executed. The array element numbers correspond to the following: 0: RAW_DATA, 1: ANL_DATA, 2: FTR_DATA, 3: AIS_DATA, 4 to 31: Reserved				
Data type	Structure: ARRAY [0..31] OF _sTSDB_TSSTA, Member: BOOL			Range of values	TRUE or FALSE
R/W access	R	Retained	Not retained.	Network Publish	Published.
Usage in user program	Possible.	Related instructions	---		

Variable name	_TSDB_TSSta			Member name	.IsExpt
Meaning	Export Execution Flag			Global/local	Global
Function	TRUE when export is being executed. The array element numbers correspond to the following: 0: RAW_DATA, 1: ANL_DATA, 2: FTR_DATA, 3: AIS_DATA, 4 to 31: Reserved				
Data type	Structure: ARRAY [0..31] OF _sTSDB_TSSTA, Member: BOOL			Range of values	TRUE or FALSE
R/W access	R	Retained	Not retained.	Network Publish	Published.
Usage in user program	Possible.	Related instructions	---		

Variable name	_TSDB_TSSta			Member name	.IsExptRec
Meaning	Export Record Existence Flag			Global/local	Global
Function	TRUE when export is being executed and the record to be exported exists. The array element numbers correspond to the following: 0: RAW_DATA, 1: ANL_DATA, 2: FTR_DATA, 3: AIS_DATA, 4 to 31: Reserved				
Data type	Structure: ARRAY [0..31] OF _sTSDB_TSSTA, Member: BOOL			Range of values	TRUE or FALSE
R/W access	R	Retained	Not retained.	Network Publish	Published.
Usage in user program	Possible.	Related instructions	---		

Variable name	_TSDB_TSSta			Member name	.OpenErr
Meaning	Sampling Mode Open Error Flag			Global/local	Global
Function	TRUE when an error occurred during TimeSeries open processing. The array element numbers correspond to the following: 0: RAW_DATA, 1: ANL_DATA, 2: FTR_DATA, 3: AIS_DATA, 4 to 31: Reserved				
Data type	Structure: ARRAY [0..31] OF _sTSDB_TSSTA, Member: BOOL			Range of values	TRUE or FALSE
R/W access	R	Retained	Not retained.	Network Publish	Published.
Usage in user program	Possible.	Related instructions	---		

Variable name	_TSDB_TSSta			Member name	.SmplErr
Meaning	Sampling Error Flag			Global/local	Global
Function	TRUE when there is an error in the sampling. The array element numbers correspond to the following: 0: RAW_DATA, 1: ANL_DATA, 2: FTR_DATA, 3: AIS_DATA, 4 to 31: Reserved				
Data type	Structure: ARRAY [0..31] OF _sTSDB_TSSTA, Member: BOOL			Range of values	TRUE or FALSE
R/W access	R	Retained	Not retained.	Network Publish	Published.
Usage in user program	Possible.	Related instructions	---		

Variable name	_TSDB_TSSta			Member name	.ExptErr
Meaning	Export Error Flag			Global/local	Global
Function	TRUE when there is an error in the export. The array element numbers correspond to the following: 0: RAW_DATA, 1: ANL_DATA, 2: FTR_DATA, 3: AIS_DATA, 4 to 31: Reserved				
Data type	Structure: ARRAY [0..31] OF _sTSDB_TSSTA, Member: BOOL			Range of values	TRUE or FALSE
R/W access	R	Retained	Not retained.	Network Publish	Published.
Usage in user program	Possible.	Related instructions	---		

Variable name	_TSDB_TSSta			Member name	.ErrCode
Meaning	Error Cause Code			Global/local	Global
Function	Specifies the cause of the error occurred in TimeSeries.*1 The array element numbers correspond to the following: 0: RAW_DATA, 1: ANL_DATA, 2: FTR_DATA, 3: AIS_DATA, 4 to 31: Reserved				
Data type	Structure: ARRAY [0..31] OF _sTSDB_TSSTA, Member: WORD			Range of values	Depends on the data type.
R/W access	R	Retained	Not retained.	Network Publish	Published.
Usage in user program	Possible.	Related instructions	---		

*1. ErrorCode (Error Cause Code) is described below.

Err-Code	Event name	Description	Correction
4C00 hex	TSDB Service Not Started	The TSDB service status is not <i>Running</i> .	Check to see if the TSDB service is <i>Running</i> on the AI Operator.
4C01 hex	Invalid TimeSeries Name	A value other than 'RAW_DATA', 'ANL_DATA', 'FTR_DATA', or 'AIS_DATA' was specified for the <i>TimeSeriesName</i> input variable in the time series database instruction.	Check <i>TimeSeriesName</i> input variable in the time series database instruction.
4C03 hex	Setting Error	Any of the following occurred: <ul style="list-style-type: none"> A variable that does not exist in the AI Controller was downloaded from the AI Operator. An incorrect value is included in the settings of the Time Series Database Function. 	Download data to the AI Controller again in the following orders: <ol style="list-style-type: none"> Download a project from the Sysmac Studio Download the settings from the AI Operator Click the Reconstruct Button for the TimeSeries on the AI Operator.
4C05 hex	Exporting	The time series database instruction was executed while the target TimeSeries was being exported.	Execute the time series database instruction while the target TimeSeries is not being exported.
4C07 hex	Too Many TimeSeries	The number of TimeSeries that can be opened simultaneously, is exceeded.	Contact an engineer of OMRON.
4C08 hex	TimeSeries Open Failed	Opening the TimeSeries failed.	Check to see if the following storage is inserted properly and it is not write-protected. NX-series: SD Memory Card NY-series: Expanded storage in drive bay A
4C0B hex	TimeSeries Access Failed	Accessing the TimeSeries failed.	Check to see if the following storage is inserted properly and it is not write-protected. NX-series: SD Memory Card NY-series: Expanded storage in drive bay A
4C0C hex	Insufficient TimeSeries Resources	There is not sufficient resources to execute the time series database instruction.	Contact an engineer of OMRON.
4C0D hex	TSDB Service Control Disabled	While the TSDB service was in the <i>Error</i> or <i>Shutdown</i> status, the <i>TimeSeries_ControlService</i> instruction was executed as a <i>start command</i> or a <i>stop command</i> .	Execute the <i>TimeSeries_ControlService</i> instruction while the TSDB service is in the <i>Idle</i> or <i>Running</i> status.

Err-Code	Event name	Description	Correction
4C0E hex	Time Series Database Instruction Timeout	Sampling or export processing timed out.	Contact an engineer of OMRON.
4C12 hex	TimeSeries Corrupted	The TimeSeries cannot be opened because it is corrupted.	<ul style="list-style-type: none"> On the AI Operator, click the Reconstruct Button for the corrupted TimeSeries. Cycle the power supply to the AI Controller.
4C13 hex	Invalid Operation	Unauthorized operation was performed for the specified TimeSeries.	Do not write values to the following system-defined variables. _TSDB_SmplStartCmd[2] _TSDB_SmplStopCmd[2] _TSDB_SmplStartCmd[3] _TSDB_SmplStopCmd[3]
4C14 hex	Insufficient Capacity in Export Destination	The storage to which the CSV file from the AI Controller is exported has run out of space.	Check to see if CSV files in the AI Controller have been transferred to your computer on the AI Operator or transferred to a web server with the WebAPI Connection Function.

Variable name	_TSDB_SmplStartCmd		
Meaning	Sampling Start Command	Global/local	Global
Function	TRUE when you start sampling of the TimeSeries. The array element numbers correspond to the following: 0: RAW_DATA, 1: ANL_DATA, 2: FTR_DATA, 3: AIS_DATA, 4 to 31: Reserved		
Data type	ARRAY [0..31] OF BOOL	Range of values	TRUE or FALSE
R/W access	RW	Retained	Not retained.
Usage in user program	Possible.*1	Related instructions	---

*1. However, do not change the value for _TSDB_SmplStartCmd[2] and _TSDB_SmplStartCmd[3].

Variable name	_TSDB_SmplStopCmd		
Meaning	Sampling Stop Command	Global/local	Global
Function	TRUE when you stop sampling of the TimeSeries. The array element numbers correspond to the following: 0: RAW_DATA, 1: ANL_DATA, 2: FTR_DATA, 3: AIS_DATA, 4 to 31: Reserved		
Data type	ARRAY [0..31] OF BOOL	Range of values	TRUE or FALSE
R/W access	RW	Retained	Not retained.
Usage in user program	Possible.*1	Related instructions	---

*1. However, do not change the value for _TSDB_SmplStopCmd[2] and _TSDB_SmplStopCmd[3].

Variable name	_TSDB_ExptStartCmd		
Meaning	Export Start Command	Global/local	Global
Function	TRUE when you start export of the TimeSeries. The array element numbers correspond to the following: 0: RAW_DATA, 1: ANL_DATA, 2: FTR_DATA, 3: AIS_DATA, 4 to 31: Reserved		
Data type	ARRAY [0..31] OF BOOL	Range of values	TRUE or FALSE
R/W access	RW	Retained	Not retained.
Usage in user program	Possible.	Related instructions	---

Variable name	_TSDB_ExptStopCmd				
Meaning	Export Stop Command	Global/local		Global	
Function	TRUE when you stop export of the TimeSeries. The array element numbers correspond to the following: 0: RAW_DATA, 1: ANL_DATA, 2: FTR_DATA, 3: AIS_DATA, 4 to 31: Reserved				
Data type	ARRAY [0..31] OF BOOL	Range of values		TRUE or FALSE	
R/W access	RW	Retained	Not retained.	Network Publish	Published.
Usage in user program	Possible.	Related instructions	---		

Variable name	_TSDB_ClearCmd				
Meaning	TimeSeries Clear Command	Global/local		Global	
Function	TRUE when you clear data in the TimeSeries. The array element numbers correspond to the following: 0: RAW_DATA, 1: ANL_DATA, 2: FTR_DATA, 3: AIS_DATA, 4 to 31: Reserved				
Data type	ARRAY [0..31] OF BOOL	Range of values		TRUE or FALSE	
R/W access	RW	Retained	Not retained.	Network Publish	Published.
Usage in user program	Possible.	Related instructions	---		

Variable name	_TSDB_SmplMode				
Meaning	TimeSeries Sampling Mode	Global/local		Global	
Function	Shows the mode of the defined TimeSeries. 0: Not used 1: Simple mode The array element numbers correspond to the following: 0: RAW_DATA, 1: ANL_DATA, 2: FTR_DATA, 3: AIS_DATA, 4 to 31: Reserved				
Data type	ARRAY[0..31] OF UINT	Range of values		0 or 1	
R/W access	R	Retained	Not retained.	Network Publish	Published.
Usage in user program	Possible.	Related instructions	---		

Variable name	_TSDB_CreateCmd				
Meaning	TimeSeries Creation Command	Global/local		Global	
Function	Issue a command to recreate a TimeSeries. While the TSDB service status is idle, this flag can be switched from FALSE to TRUE. You can also recreate a TimeSeries by opening the Monitor/Operation screen on AI Operator and selecting TimeSeries , and then pressing the Reconstruct Button. The array element numbers correspond to the following: 0: RAW_DATA, 1: ANL_DATA, 2: FTR_DATA, 3: AIS_DATA, 4 to 31: Reserved				
Data type	ARRAY[0..31] OF BOOL	Range of values		TRUE or FALSE	
R/W access	RW	Retained	Not retained.	Network Publish	Published.
Usage in user program	Possible.	Related instructions	---		

A-3-4 AI Function Modules, Category Name: _FE

● Feature Extraction Function

Variable name	_FE_Enable		
Meaning	Feature Extraction Service Enable Command	Global/local	Global
Function	Send a command to change the status of the feature extraction service. TRUE when you change the status to Running. FALSE when you change the status to Idle.		
Data type	BOOL	Range of values	TRUE or FALSE
R/W access	RW	Retained	Not retained.
Usage in user program	Possible.	Related instructions	---

Variable name	_FE_Result		
Meaning	Feature Value	Global/local	Global
Function	Shows the extracted feature value.		
Data type	ARRAY [0..127, 0..15] OF LREAL	Range of values	Depends on the data type.
R/W access	RW	Retained	Not retained.
Usage in user program	Possible.	Related instructions	---

Variable name	_FE_Status		
Meaning	Feature Extraction Service Status	Global/local	Global
Function	Shows the status of the Feature Extraction Function. _FE_STATUS_INITIALIZE: Initializing _FE_STATUS_LOAD: Loading _FE_STATUS_IDLE: Idle _FE_STATUS_RUN: Running _FE_STATUS_PARAMETER_ERROR: Error		
Data type	_eFE_STATUS	Range of values	Depends on the data type.
R/W access	R	Retained	Not retained.
Usage in user program	Possible.	Related instructions	---

A-3-5 AI Function Modules, Category Name: _MLE

● Machine Learning Function

Variable name	_MLE_Enable		
Meaning	Machine Learning Service Enable Command	Global/local	Global
Function	Send a command to change the status of the machine learning service. TRUE when you change the status to Running. FALSE when you change the status to Idle.		
Data type	BOOL	Range of values	TRUE or FALSE
R/W access	RW	Retained	Not retained.
Usage in user program	Possible.	Related instructions	---

Variable name	_MLE_Result			Member name	.Level
Meaning	Level Judgment Result			Global/local	Global
Function	Shows the level judgment result. -1: Judgment failed 0: Initial value (not tested) 1: Normal 2: Alarm level 1 3: Alarm level 2				
Data type	Structure: ARRAY [0..127] OF _sMLE_RESULT Member: INT			Range of values	-1 to 3
R/W access	R	Retained	Not retained.	Network Publish	Published.
Usage in user program	Possible.	Related instructions	---		

Variable name	_MLE_Result			Member name	.Score
Meaning	Equipment Event Monitoring Score			Global/local	Global
Function	Shows the equipment event monitoring score. Judgment failed: -∞				
Data type	Structure: ARRAY [0..127] OF _sMLE_RESULT Member: LREAL			Range of values	Depends on the data type.
R/W access	R	Retained	Not retained.	Network Publish	Published.
Usage in user program	Possible.	Related instructions	---		

Variable name	_MLE_Status			Global/local	Global
Meaning	Machine Learning Service Status				
Function	Shows the status of the Machine Learning Function. _MLE_STATUS_INITIALIZE: Initializing _MLE_STATUS_LOAD: Loading _MLE_STATUS_IDLE: Idle _MLE_STATUS_RUN: Running _MLE_STATUS_PARAMETER_ERROR: Error				
Data type	_eMLE_STATUS			Range of values	Depends on the data type.
R/W access	R	Retained	Not retained.	Network Publish	Published.
Usage in user program	Possible.	Related instructions	---		

Variable name	_MLE_Statistics			Member name	.Level1Count
Meaning	Number of Level 1 Judgment Results			Global/local	Global
Function	Shows the number of results judged as Normal.				
Data type	Structure: ARRAY [0..127] OF _sMLE_STATISTICS Member: UDINT			Range of values	Depends on the data type.
R/W access	R	Retained	Not retained.	Network Publish	Published.
Usage in user program	Possible.	Related instructions	---		

Variable name	_MLE_Statistics			Member name	.Level2Count
Meaning	Number of Level 2 Judgment Results			Global/local	Global
Function	Shows the number of results judged as Alarm level 1.				
Data type	Structure: ARRAY [0..127] OF _sMLE_STATISTICS Member: UDINT			Range of values	Depends on the data type.
R/W access	R	Retained	Not retained.	Network Publish	Published.
Usage in user program	Possible.	Related instructions	---		

Variable name	_MLE_Statistics			Member name	.Level3Count
Meaning	Number of Level 3 Judgment Results			Global/local	Global
Function	Shows the number of results judged as Alarm level 2.				
Data type	Structure: ARRAY [0..127] OF _sMLE_STATISTICS Member: UDINT			Range of values	Depends on the data type.
R/W access	R	Retained	Not retained.	Network Publish	Published.
Usage in user program	Possible.	Related instructions	---		

Variable name	_MLE_Statistics			Member name	.ErrorFrameCount
Meaning	Number of Frames That Failed the Judgment			Global/local	Global
Function	Shows the number of frames of which feature value calculation resulted in an error or judgment failed.				
Data type	Structure: ARRAY [0..127] OF _sMLE_STATISTICS Member: UDINT			Range of values	Depends on the data type.
R/W access	R	Retained	Not retained.	Network Publish	Published.
Usage in user program	Possible.	Related instructions	---		

Variable name	_MLE_Statistics			Member name	.ErrorID
Meaning	Cause of the Last Failed Judgment for the Frame			Global/local	Global
Function	Shows the cause of the last failed judgment for the frame. 1: Input data is invalid (Feature value calculation result is $-\infty$, $+\infty$, or not a number) 2: Frame omission due to exceeded judgment				
Data type	Structure: ARRAY [0..127] OF _sMLE_STATISTICS Member: DWORD			Range of values	1 to 2
R/W access	R	Retained	Not retained.	Network Publish	Published.
Usage in user program	Possible.	Related instructions	---		

A-3-6 AI Function Modules, Category Name: _WAC

● **Functional Classification: WebAPI Connection Functions**

Variable name	_WAC_Version				
Meaning	WebAPI Version		Global/local	Global	
Function	Shows the version of the WebAPI package. The integer part of the version is stored in the element number 0. The fractional part of the version is stored in the element number 1. Example) If the WebAPI version is 1.10, 1 is stored in the element number 0 and 10 is stored in the element number 1.				
Data type	ARRAY [0..1] OF USINT		Range of values	0 to 99	
R/W access	R	Retained	Not retained.	Network Publish	Published.
Usage in user program	Possible.	Related instructions	---		

A-4 Processing in the Data Collection, Data Analysis, and Data Utilization Phases

This section describes the processing executed in the Data Collection, Data Analysis, and Data Utilization Phases.

Use this information to understand the operational specifications of the AI Controllers.

A-4-1 Data Collection Phase

In the Data Collection Phase, the Time Series Database Function collects values of the frame variables, variable data, and subframe variables of each equipment event. They are collected in TimeSeries as analysis data. Up to 16 variable data and up to 6 subframe variables can be set per equipment event. Up to 128 equipment events can be registered.

For details on the format of *ANL-****.csv* files that are saved in the built-in RAM, refer to *A-5 CSV File Format* on page A-32.

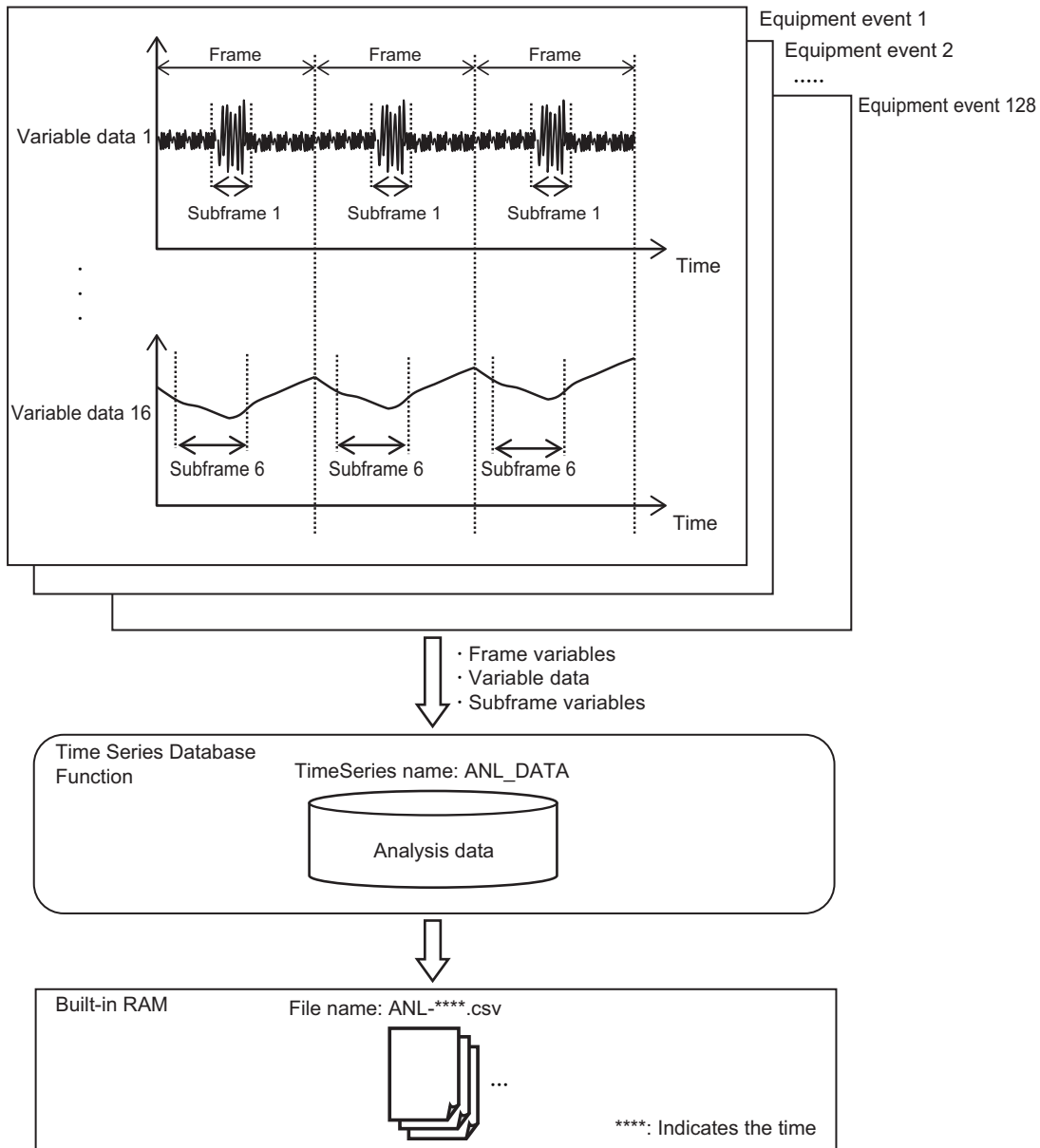

A-4-2 Data Analysis Phase

An engineer of OMRON generates the AI machine learning model from the analysis data. In this phase, an AI machine learning model is generated and downloaded to the AI Controller. The AI machine learning model is used in the Data Utilization Phase.

Some of the data included in the AI machine learning model is described below.

- Frame variable name, variable data name, subframe variable name
- Feature value calculation method
- Data used for calculating equipment event monitoring score
- Threshold 1, Threshold 2

A-4-3 Data Utilization Phase

In the Data Utilization Phase, the Feature Value/Machine Learning Function of the AI Controller uses the AI machine learning model and determines if any equipment event occur based on the variable

data. The Feature Value/Machine Learning Function of the AI Controller executes processing as described below.

The Feature Extraction Function of the AI Controller executes processing as follows:

(1) Variable data acquisition

According to the AI machine learning model, the function determines variable data, frame variables, and subframe variables. The calculation interval of variable data is obtained from the values of frame variables and frame variables.

(2) Feature value calculation

According to the feature value calculation method that is set to the AI machine learning mode, it calculates the feature value from the calculation interval of variable data.

The feature value is calculated for each variable data. The calculated feature value is output to the Time Series Database Function.

The Machine Learning Function of the AI Controller executes processing as follows:

(3) Calculation of equipment event monitoring score

The function calculates the equipment event monitoring score that shows a difference from the normal value with the AI machine learning model.

The equipment event monitoring score is output to the Time Series Database Function.

(4) Level judgment

Based on the threshold values defined in the AI machine learning model, the equipment event monitoring scores are determined to Normal, Alarm level 1, or Alarm level 2.

The equipment event monitoring result is output to the Time Series Database Function.

The following is an example of outputting feature values and equipment event monitoring results from the two variable data. To simplify the process, this section explained only two feature values, but you can set up to 16 feature values to each equipment event.

For details on the format of *FTR-****.csv* and *AIS-****.csv* files that are saved in the built-in RAM, refer to *A-5 CSV File Format* on page A-32.

Make sure to check if equipment events can be detected in this phase. If the events can not be detected, perform the Data Collection Phase or Data Analysis Phase again.

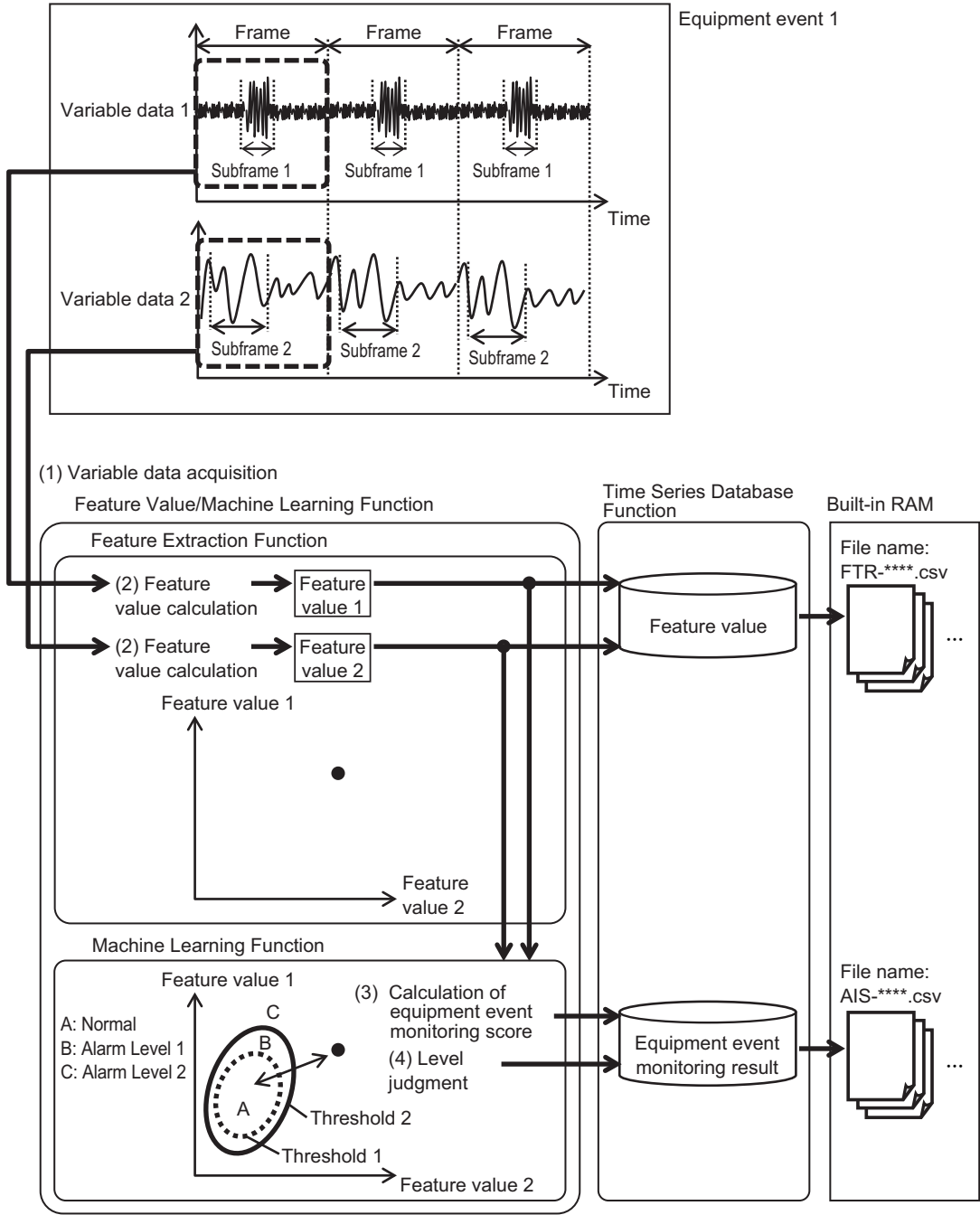

Note In a precise sense, the equipment event monitoring scores and threshold values do not represent the distance between two points on the two-dimensional coordinates. To simplify the process, this example uses them as a distance from the normal position.

A-5 CSV File Format

The formats of CSV files exported by the Time Series Database Function are described below.

A-5-1 Variable Data File (RAW-***.csv)

The formats of variable data (CSV files) exported by the Time Series Database Function are described below.

	Index	Time Stamp (Time format)	Time Stamp (Nanoseconds format)	Reserved 1	Reserved 2	Reserved 3	Reserved 4	Variable data 1	..	Variable data 1024
Header row^{*1}	indx	tmstmp	tmstmp2	schcnt	schcnt2	sid	sidx	"Variable name of variable data 1"	..	"Variable name of variable data 1024"
First record	Index value	Time Stamp value	Time Stamp value	Counter value	Counter value	Integer value	Index value	Value of variable data 1	..	Value of variable data 1024
Second record	Same as above	Same as above	Same as above	Same as above	Same as above	Same as above	Same as above	Same as above	..	Same as above
:	:	:	:	:	:	:	:	:	:	:

*1. The specified text string is always output to indx through sidx on the header row.

- Reserved 1 through 4 are used by the system.
- Up to 1024 sets of variable data can be used.
- indx (index) will increment by one (in decimal notation) for each sampling performed in TimeSeries. You can check the index value to find the omitted collection data.
- The Time Stamp (Time format) is output in the format of "yyyy-MM-dd hh:mm:ss.000000" including the microseconds part.
- The Time Stamp (Nanoseconds format) is output as the elapsed time from 1970/01/01 00:00:00 in the units of nanoseconds.
- CR+LF indicates a line feed.
- Variable data is output in the following formats based on the data type. For array variables, each element of the array is output to a column.

Data type	Type name in IEC1131-3	Output format
Boolean	BOOL	"0" or "1"
Bit string	BYTE, WORD, DWORD, LWORD	Decimal notation
Integer	SINT, INT, DINT, LINT, USINT, UINT, UDINT, ULINT	Decimal notation

Data type	Type name in IEC1131-3	Output format
Real number	REAL	Real number or exponent (Example: -12.0, 0.0, -1.34e-12, 1.0e+6)
	LREAL	Real number or exponent (Example: -12.0, 0.0, -1.34e-12, 1.0e+6)
Date	DATE	yyyy-MM-dd (Example: 2016-11-22)
Time of day	TIME_OF_DAY	hh:mm:ss.000000000 (Example: 15:37:42.123456789)
Date and time	DATE_AND_TIME	yyyy-MM-dd hh:mm:ss.000000000 (Example: 2016-11-22 15:37:42.123456789)
Duration	TIME	Decimal notation. The unit is in milliseconds. Six decimal places are specified. (Example: 123.456789)

A-5-2 Analysis Data File (ANL-***.csv)

The formats of analysis data (CSV files) exported by the Time Series Database Function are described below.

	Index	Time Stamp (Time format)	Time Stamp (Nanoseconds format)	Reserved 1	Reserved 2	Reserved 3	Reserved 4	~
Header row*1	indx	tmstmp	tmstmp2	schcnt	schcnt2	sid	sidx	~
First record	Index value	Time Stamp value	Time Stamp value	Counter value	Counter value	Integer value	Index value	~
Second record	Same as above	Same as above	Same as above	Same as above	Same as above	Same as above	Same as above	~
:	:	:	:	:	:	:	:	~

~	Frame variable 1	..	Frame variable n	Subframe variable 1	..	Subframe variable m	~
~	"Variable name of frame variable 1"	..	"Variable name of frame variable n"	"Variable name of subframe variable 1"	..	"Variable name of subframe variable m"	~
~	Value of frame variable 1	..	Value of frame variable n	Value of subframe variable 1	..	Value of subframe variable m	~
~	Same as above	..	Same as above	Same as above	..	Same as above	~
~	:	:	:	:	:	:	~

~	Label variable 1	..	Label variable p	Variable data 1	..	Variable data q
~	"Variable name of label variable 1"	..	"Variable name of label variable p"	"Variable name of variable data 1"	..	"Variable name of variable data q"
~	Value of label variable 1	..	Value of label variable p	Value of variable data 1	..	Value of variable data q
~	Same as above	..	Same as above	Same as above	..	Same as above
~	:	:	:	:	:	:

*1. The specified text string is always output to indx through sidx on the header row.

- Frame variables, subframe variables, label variables and variable data are sorted in the order of the equipment event numbers.
- If a same frame variable, subframe variable, label variable, or variable data is specified in multiple equipment events, they are not recorded duplicately.
- Reserved 1 through 4 are used by the system.
- indx (index) will increment by one (in decimal notation) for each sampling performed in TimeSeries. You can check the index value to find the omitted collection data.
- The Time Stamp (Time format) is output in the format of "yyyy-MM-dd hh:mm:ss.000000" including the microseconds part.
- The Time Stamp (Nanoseconds format) is output as the elapsed time from 1970/01/01 00:00:00 in the units of nanoseconds.
- CR+LF indicates a line feed.
- Variables are output in the following formats based on the data type.

Data type	Type name in IEC1131-3	Output format
Boolean	BOOL	"0" or"1"
Bit string	BYTE, WORD DWORD, LWORD	Decimal notation
Integer	SINT, INT, DINT, LINT USINT, UINT, UDINT, ULINT	Decimal notation
Real number	REAL	Real number or exponent (Example: -12.0, 0.0, -1.34e-12, 1.0e+6)
	LREAL	Real number or exponent (Example: -12.0, 0.0, -1.34e-12, 1.0e+6)
Date	DATE	yyyy-MM-dd (Example: 2016-11-22)
Time of day	TIME_OF_DAY	hh:mm:ss.000000000 (Example: 15:37:42.123456789)
Date and time	DATE_AND_TIME	yyyy-MM-dd hh:mm:ss.000000000 (Example: 2016-11-22 15:37:42.123456789)
Duration	TIME	Decimal notation. The unit is in milliseconds. Six decimal places are specified. (Example: 123.456789)

A-5-3 Feature Value File (FTR-****.csv)

The formats of feature value data (CSV files) exported by the Time Series Database Function are described below.

	Index	Time Stamp (Time format)	Time Stamp (Nanoseconds format)	Reserved 1	Reserved 2	Reserved 3	Reserved 4	~
Header row ^{*1}	indx	tmstmp	tmstmp2	schcnt	schcnt2	sid	sidx	~
First record	Index value	Time Stamp value	Time Stamp value	Counter value	Counter value	Integer value	Index value	~
Second record	Same as above	Same as above	Same as above	Same as above	Same as above	Same as above	Same as above	~
:	:	:	:	:	:	:	:	~

Equipment event 0						
~	FeatureGroupIdx	Equipment event 0 "feature extraction output frame variable name"	_FE_Result[0,0]	..	_FE_Result[0,15] ^{*2}	..
~	0	Equipment event 0 "value of the feature extraction output frame variable"	Feature value	..	Feature value	..
~	Same as above	Same as above	Same as above	..	Same as above	..
~	:	:	:	:	:	..

Equipment event 127 ^{*3}						
..	FeatureGroupIdx	Equipment event 127 "feature extraction output frame variable name"	_FE_Result[127,0]	..	_FE_Result[127,15] ^{*2}	..
..	127	Equipment event 127 "value of the feature extraction output frame variable"	Feature value	..	Feature value	..
..	Same as above	Same as above	Same as above	..	Same as above	..
..	:	:	:	:	:	..

- *1. The specified text string is always output to indx through sidx on the header row.
- *2. The same number of feature values set on the AI Operator is output to an CSV file.
- *3. The same number of equipment events set on the AI Operator is output to an CSV file.

- Reserved 1 through 4 are used by the system.
- indx (index) will increment by one (in decimal notation) for each sampling performed in TimeSeries. You can check the index value to find the omitted collection data.
- The Time Stamp (Time format) is output in the format of "yyyy-MM-dd hh:mm:ss.000000" including the microseconds part.
- The Time Stamp (Nanoseconds format) is output as the elapsed time from 1970/01/01 00:00:00 in the units of nanoseconds.
- CR+LF indicates a line feed.

If multiple equipment events are registered, the Feature Value/Machine Learning Function outputs results of all the equipment events to the Time Series Database Function (feature value file: FTR-***.csv) when any of the equipment event frame switches.

A-5-4 Equipment Event Monitoring Result File (AIS-***.csv)

The formats of equipment event monitoring result files (CSV files) exported by the Time Series Database Function are described below.

	Index	Time Stamp (Time format)	Time Stamp (Nanoseconds format)	Reserved 1	Reserved 2	Reserved 3	Reserved 4	~
Header row ^{*1}	indx	tmstmp	tmstmp2	schcnt	schcnt2	sid	sidx	~
First record	Index value	Time Stamp value	Time Stamp value	Counter value	Counter value	Integer value	Index value	~
Second record	Same as above	Same as above	Same as above	Same as above	Same as above	Same as above	Same as above	~
:	:	:	:	:	:	:	:	~

Equipment event 0					
~	EquipmentEventIdx	Equipment event 0 "machine learning output frame variable name"	_MLE_Result[0].level	_MLE_Result[0].score	..
~	0	Equipment event 0 "value of the machine learning output frame variable"	Level judgment result	Equipment event monitoring score	..
~	Same as above	Same as above	Same as above	Same as above	..
~	:	:	:	:	..

Equipment event 127 ^{*2}					
..	EquipmentEventIdx	Equipment event 127 "machine learning output frame variable name"	_MLE_Result[127].level	_MLE_Result[127].score	..
..	127	Equipment event 127 "value of the machine learning output frame variable"	Level judgment result	Equipment event monitoring score	..
..	Same as above	Same as above	Same as above	Same as above	..
..	:	:	:	:	..

*1. The specified text string is always output to indx through sidx on the header row.

*2. The same number of equipment events set on the AI Operator is output to an CSV file.

- Reserved 1 through 4 are used by the system.
- indx (index) will increment by one (in decimal notation) for each sampling performed in TimeSeries. You can check the index value to find the omitted collection data.
- The Time Stamp (Time format) is output in the format of "yyyy-MM-dd hh:mm:ss.000000" including the microseconds part.
- The Time Stamp (Nanoseconds format) is output as the elapsed time from 1970/01/01 00:00:00 in the units of nanoseconds.
- CR+LF indicates a line feed.

If multiple equipment events are registered, the Feature Value/Machine Learning Function outputs results of all the equipment events to the Time Series Database Function (equipment event monitoring result: AIS-****.csv) when any of the equipment event frame switches.

A-6 Version Information

This section describes the relationship between the unit versions of AI Controllers and each software version.

A-6-1 Version Information for NX-series AI Controllers

This following table gives the relationship between the unit versions of NX-series AI Controllers and the corresponding versions for each software.

Unit version of AI Controller	Corresponding version of Sysmac Studio	Version of the AI Controller software (AI Operator, AI Viewer)
Ver.1.21 ^{*1}	Ver.1.29	Ver.1.00
Ver.1.18	Ver.1.25	Ver.1.00

*1. There is no NX-series AI Controller with unit version 1.19 or later and unit version earlier than 1.21.

A-6-2 Version Information for NY-series AI Controllers

This following table gives the relationship between the unit versions of NY-series AI Controllers and the corresponding versions for each software.

Unit version of AI Controller	Corresponding version of Sysmac Studio	Version of the AI Controller software (AI Operator, AI Viewer)	Industrial PC Support Utility	Rescue Disk Creator
Ver.1.21 ^{*1}	Ver.1.29	Ver.1.00	Ver.1.1.1545	Ver.1.1.2004.01000 00040
Ver.1.18	Ver.1.25	Ver.1.00	Ver.1.1.1541.0	Ver.1.1.2004.01000 00040

*1. There is no NY-series AI Controller with unit version 1.19 or later and unit version earlier than 1.21.

A-6-3 Specifications When Not Using the Sysmac Studio Version That Corresponds to the Unit Version of the AI Controller

The specifications when you do not use the Sysmac Studio version that corresponds to the unit version of AI Controller are given in this section.

Using Sysmac Studio Version 1.24 or Lower

You cannot use the AI Controller with Sysmac Studio version 1.24 or lower.

Using a Lower Version of Sysmac Studio

If you use a lower version of the Sysmac Studio, you can use only the functions of the unit version of the AI Controller that corresponds to the Sysmac Studio version.

Example: Unit version of AI Controller: 1.21

Sysmac Studio version: 1.25

Unit version 1.18 of the AI Controller corresponds to Sysmac Studio version 1.25. Therefore, you can use only the functions that are supported by unit version 1.18 of the AI Controller. You cannot use functionality that was added for unit version 1.21 or later of the AI Controller.

Using an AI Controller with an Earlier Unit Version

If you use an AI Controller with an earlier version, select the unit version of the used AI Controller or an earlier unit version in the Select Device Area of the Project Properties Dialog Box on the Sysmac Studio. The unit version that you selected is the project unit version of the project. You can use only the functions that are supported by the project unit version.

Example: Unit version of AI Controller: 1.18

Sysmac Studio version: 1.29

Unit version 1.21 of the AI Controller corresponds to Sysmac Studio version 1.29. However, the used AI Controller is unit version 1.18, so select version 1.18 as the version in the Select Device Area of the Project Properties Dialog Box.

If you select version 1.18 as the version in the Select Device Area of the Project Properties Dialog Box, you can use only the functions that are supported by project unit version 1.18. You cannot use functionality that was added for unit version 1.21 or later of the AI Controller.



Additional Information

Project Unit Version for Projects

- With Sysmac Studio version 1.02 or higher, you can select the unit version in the Select Device Area of the relevant dialog boxes.
- You can select any unit version that is the same as or earlier than the unit version of the AI Controller. For example, if the unit version of the AI Controller is 1.21, select either 1.18 or 1.21.
- The Sysmac Studio will treat the project unit version as the unit version for the AI Controller. For example, if the project unit version is 1.18, you can use only the functionality for unit version 1.18 on the Sysmac Studio.
- You can transfer a project to the Sysmac Studio if the project unit version is the same as or earlier than the unit version of the destination AI Controller.
- Refer to the *Sysmac Studio Version 1 Operation Manual (Cat. No. W504)* for details on the Select Device Area of the relevant dialog boxes.



Index



Index

Numerics

_AIC_Version (AIC Version).....	A-6, A-17
_Card1Capacity (SD Memory Card Storage Capacity).....	A-6, A-14
_Card1RestoreCmdTargetAicMLD (AI Machine Learning Model Transfer Flag).....	A-7, A-15
_Card1Used (SD Memory Card Storage Usage)....	A-7, A-15
_ExtendedStorage1Capacity (Extended Storage1 Capacity).....	A-7, A-15
_ExtendedStorage1Ready (Extended Storage1 Ready Flag).....	A-7, A-15
_ExtendedStorage1Used (Extended Storage1 Usage).....	A-7, A-16
_ExtendedStorage2Capacity (Extended Storage2 Capacity).....	A-7, A-16
_ExtendedStorage2Ready (Extended Storage2 Ready Flag).....	A-7, A-16
_ExtendedStorage2Used (Extended Storage2 Usage).....	A-8, A-16
_FE_Enable (Feature Extraction Service Enable Command).....	A-10, A-24
_FE_Result (Feature Value).....	A-10, A-24
_FE_Status (Feature Extraction Service Status)....	A-10, A-24
_MLE_Enable (Machine Learning Service Enable Command).....	A-12, A-24
_MLE_Result (Equipment Event Monitoring Result).....	A-11, A-25
_MLE_Statistics (Statistics on Equipment Event Monitoring Result).....	A-11, A-25
_MLE_Status (Machine Learning Service Status). A-11,	A-25
_WAC_Version (WebAPI Version).....	A-13
(TimeSeries Name).....	A-18

A

AI machine learning model.....	27
AI Machine Learning Model Transfer Flag.....	A-7, A-15
AI Operator.....	27
AI Predictive Maintenance Library.....	27
AI Viewer.....	27
AIC.....	27
AIC Version.....	A-6, A-17
Analysis data file.....	28

C

Control Export Status.....	5-8
Control Sampling Status.....	5-6
Control TSDB Service Status.....	5-2

D

Directory Access Failed.....	8-44
------------------------------	------

E

equipment event.....	27
equipment event monitoring result.....	27
Equipment Event Monitoring Result.....	A-11
Equipment event monitoring result file.....	27
equipment event monitoring score.....	27
Event code.....	8-7 – 8-15
Event name.....	8-7 – 8-15
Expanded Storage Available.....	8-18
Expanded Storage Data Corrupted.....	8-18
Expanded Storage Life.....	8-17
Export Start Command.....	A-9, A-22
Export Started.....	8-31
Export Stop Command.....	A-9, A-23
Export Stopped.....	8-32
Extended Storage1 Capacity.....	A-7, A-15
Extended Storage1 Ready Flag.....	A-7, A-15
Extended Storage1 Usage.....	A-7, A-16
Extended Storage2 Capacity.....	A-7, A-16
Extended Storage2 Ready Flag.....	A-7, A-16
Extended Storage2 Usage.....	A-8, A-16

F

_FE_Enable (Feature Extraction Service Enable Command).....	A-10, A-24
_FE_Result (Feature Value).....	A-10, A-24
_FE_Status (Feature Extraction Service Status)....	A-10, A-24
feature extraction output frame variables.....	27
Feature Extraction Service Enable Command.....	A-10, A-24
Feature Extraction Service Started.....	8-37
Feature Extraction Service Status.....	A-10, A-24
Feature Extraction Service Stopped.....	8-36
Feature Extraction Service TimeSeries Write Error.....	8-35
Feature Extraction Setting Changed.....	8-36
Feature Extraction Setting Error.....	8-33
feature value.....	27
Feature Value.....	A-10, A-24
feature value calculation method.....	27
Feature value file.....	28
Feature Value/Machine Learning Function.....	27
File Deletion Failed.....	8-45
File Upload Failed.....	8-46
File Upload Succeeded.....	8-49
frame.....	28

I

Insufficient TimeSeries Resources.....	8-50
Isolation Forest.....	27

L

Level Judgment Result.....	A-25
----------------------------	------

M

machine learning output frame variables..... 27
 Machine Learning Service Enable Command A-12, A-24
 Machine Learning Service Setting Changed..... 8-41
 Machine Learning Service Setting Error..... 8-38
 Machine Learning Service Started..... 8-42
 Machine Learning Service Status..... A-11, A-25
 Machine Learning Service Stopped..... 8-41
 Machine Learning Service TimeSeries Write Error..... 8-40
 _MLE_Enable (Machine Learning Service Enable Com-
 mand)..... A-12, A-24
 _MLE_Result (Level Judgment Result)..... A-25
 _MLE_Statistics (Statistics on Equipment Event Monitoring
 Result)..... A-11, A-25
 _MLE_Status (Machine Learning Service Status). A-11, A-25

P

PLC System Processing Error..... 8-34, 8-39

R

root certificate..... 28

S

Sampling Start Command..... A-9, A-22
 Sampling Started..... 8-30
 Sampling Stop Command..... A-9, A-22
 Sampling Stopped..... 8-31
 SD Memory Card Storage Capacity..... A-6, A-14
 SD Memory Card Storage Usage..... A-7, A-15
 server certificate..... 27
 Statistics on Equipment Event Monitoring Result.. A-11, A-25
 subframe..... 27

T

Time Series Database Function..... 27
 Time Series Database Setting Error..... 8-21
 Timeout Occurred..... 8-25
 TimeSeries..... 27
 TimeSeries Clear Command..... A-9, A-23
 TimeSeries Creation Command..... A-9, A-23
 TimeSeries Creation Failed..... 8-19
 TimeSeries Deletion Failed..... 8-19
 TimeSeries Error..... 8-23
 TimeSeries Name..... A-8
 TimeSeries Open Failed..... 8-24
 TimeSeries Record Addition Failed Lost..... 8-27
 TimeSeries Record Addition Request Lost..... 8-26
 TimeSeries Record Export Failed..... 8-20
 TimeSeries Sampling Mode..... A-9, A-23
 TimeSeries Setting Update Failed..... 8-22
 TimeSeries Setting Updated..... 8-32
 TimeSeries Status..... A-8, A-18
 TimeSeries Time Backward Counter Overflow..... 8-28
 TimeSeries Time Index Overflow..... 8-28
 TimeSeries_ControlExport..... 5-8

TimeSeries_ControlSampling..... 5-6
 TimeSeries_ControlService (TSDB Service Operation Com-
 mands)..... 5-2
 TSDB..... 27
 TSDB Service Control Disabled..... 8-51
 TSDB Service Memory Allocation Failed..... 8-22
 TSDB Service Shutdown..... 8-30
 TSDB Service Shutdown Command..... A-8, A-18
 TSDB Service Started..... 8-29
 TSDB Service Startup Failed..... 8-21
 TSDB Service Status..... A-8, A-17
 TSDB Service Stopped..... 8-29
 TSDB Service Version..... A-10, A-17
 _TSDB_ClearCmd (TimeSeries Clear Command).. A-9, A-23
 _TSDB_CreateCmd (TimeSeries Creation Command).....
 A-9, A-23
 _TSDB_ExptStartCmd (Export Start Command).... A-9, A-22
 _TSDB_ExptStopCmd (Export Stop Command).... A-9, A-23
 _TSDB_ShutdownCmd (TSDB Service Shutdown Com-
 mand)..... A-8, A-18
 _TSDB_SmplMode (TimeSeries Sampling Mode).. A-9, A-23
 _TSDB_SmplStartCmd (Sampling Start Command).....
 A-9, A-22
 _TSDB_SmplStopCmd (Sampling Stop Command).....
 A-9, A-22
 _TSDB_Status (TSDB Service Status)..... A-8, A-17
 _TSDB_TSName (TimeSeries Name)..... A-8, A-18
 _TSDB_TSSSta (TimeSeries Status)..... A-8, A-18
 _TSDB_Version (TSDB Service Version)..... A-10, A-17

V

Variable data file..... 28

W

WAC..... 27
 WebAPI Connection Function..... 27
 WebAPI Connection Service Certificate Imported..... 8-50
 WebAPI Connection Service Root Certificate Expiration No-
 tice..... 8-47
 WebAPI Connection Service Setting Error..... 8-43
 WebAPI Connection Service Setting Updated..... 8-49
 WebAPI Connection Service Started..... 8-48
 WebAPI Connection Service Stopped..... 8-48
 WebAPI Connection Service System Processing Error.. 8-44
 WebAPI Version..... A-13
 Write Protection Key..... A-2

OMRON Corporation Industrial Automation Company
Kyoto, JAPAN

Contact: www.ia.omron.com

Regional Headquarters

OMRON EUROPE B.V.

Wegalaan 67-69, 2132 JD Hoofddorp
The Netherlands
Tel: (31)2356-81-300/Fax: (31)2356-81-388

OMRON ELECTRONICS LLC

2895 Greenspoint Parkway, Suite 200
Hoffman Estates, IL 60169 U.S.A.
Tel: (1) 847-843-7900/Fax: (1) 847-843-7787

OMRON ASIA PACIFIC PTE. LTD.

No. 438A Alexandra Road # 05-05/08 (Lobby 2),
Alexandra Technopark,
Singapore 119967
Tel: (65) 6835-3011/Fax: (65) 6835-2711

OMRON (CHINA) CO., LTD.

Room 2211, Bank of China Tower,
200 Yin Cheng Zhong Road,
PuDong New Area, Shanghai, 200120, China
Tel: (86) 21-5037-2222/Fax: (86) 21-5037-2200

Authorized Distributor:

© OMRON Corporation 2018-2019 All Rights Reserved.
In the interest of product improvement,
specifications are subject to change without notice.

Cat. No. W594-E1-02

0719