

# Panel condition monitoring device

K6PM

Into the new era of  
maintenance by IoT

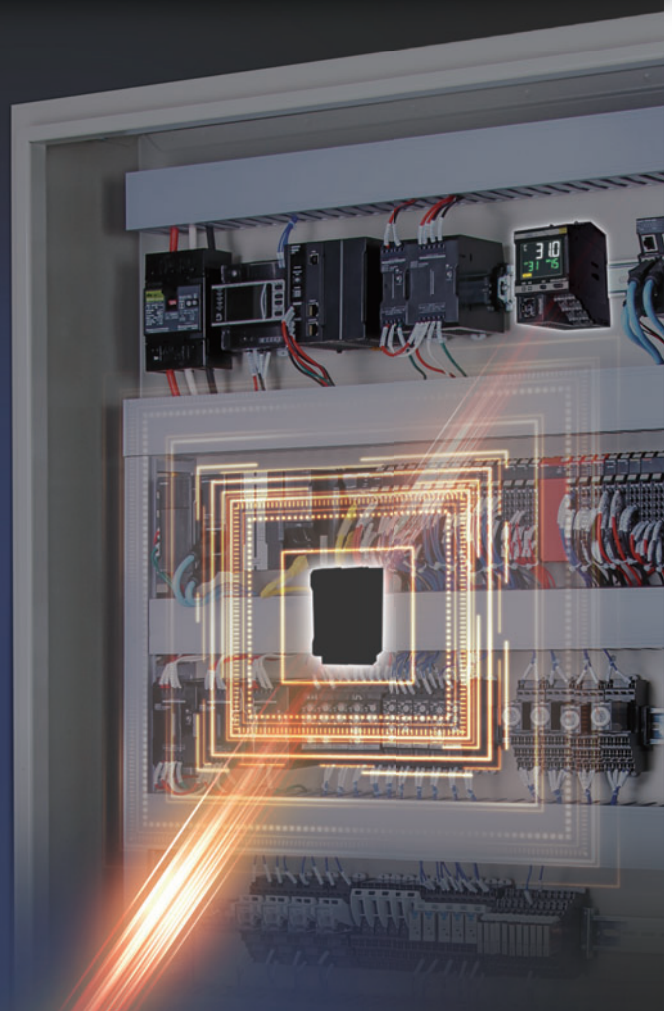

# Remote monitoring with realtime analysis of the panel status IoT change the style of maintenance

## Contributing to "Zero-downtime" of facilities and equipment.

A shortage of human maintenance resources can lead to a device failure in a panel, which will increase a risk of serious accidents or facilities stop.  
OMRON proposes you a new way of maintenance where every panel in your plant is under surveillance without human resource through the constant temperature monitoring powered by IoT.

Reduce both of maintenance labor and risk of abnormal stop by the maintenance utilizing constant remote monitoring

### Skillless

Our unique algorithm will allow inexperienced personnel to recognize an abnormality and to maintain without help from skilled engineers.

### Labor-saving and maintenance-hours reduction

Constant and remote monitoring of the temperature status is available, on-site maintenance is needed only when an abnormal occurs.

### Predictive maintenance

A prediction of temperature deviation over time provides early detection of an abnormal tendency and scheduled maintenance.







Note. This product is designed for monitoring of abnormal modes resulting , not for detecting a fire without any fault.

# Automatic capture of temperature deviation in a panel labor-saving and significant risk mitigation of abnormal

## Issues on site

Parts to check are increasing as devices and wires in a panel increase for high-functioned facilities and equipment. On the other hand, maintenance frequency is decreasing due to shortage of the maintenance engineers, resulting in a higher risk of accident.

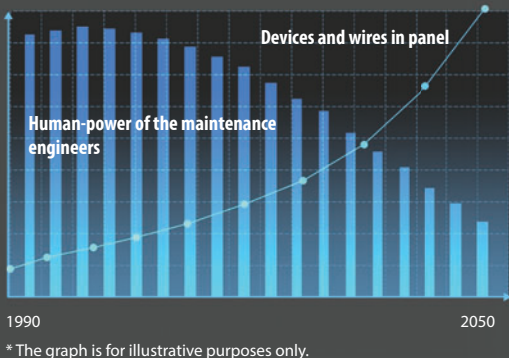

\*The graph is for illustrative purposes only.



## Importance of the temperature monitoring

Device failures have various causes; most of which leads to insulator breakage due to overheating, resulting in an abnormal stop.

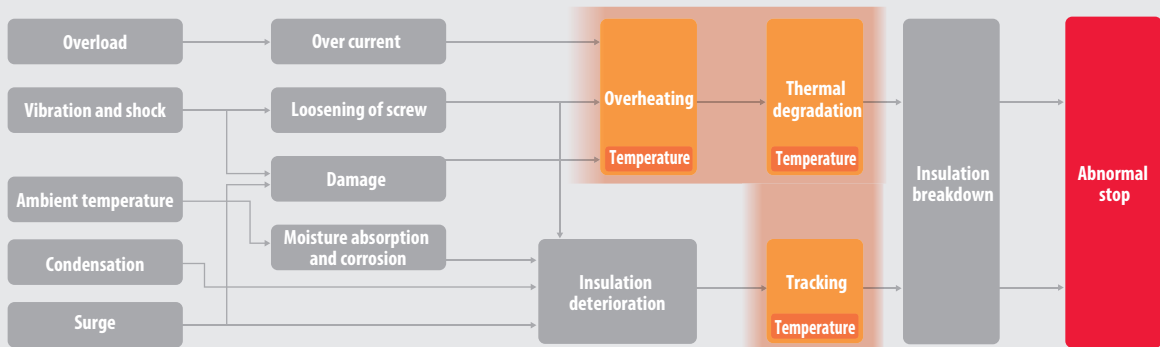

Most of the abnormal modes show symptoms in the temperature deviation.

## Current way of maintenance





- A few skilled maintenance engineers manually check relying on their experiences.
- Their checking scope covers only a part of the panel, making it impossible to constantly monitor the status of whole panel.

### Measurement method of the temperature in a panel

No constant measurement method is available for temperatures in a whole panel.

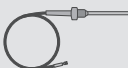
### Collecting and analyzing method of temperature data

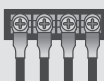
Know-how of skilled engineers is necessary, only partial data can be collected.

	A part of the panel	Whole panel
Constant monitoring	One-point monitoring with a thermocouple 	
Periodic monitoring	Terminal cap for exothermic monitoring 	Thermo viewer 





# for maintenance labors, to achieve both stop

**New way of maintenance**

- Covering the skilled maintenance engineers, the thermal condition monitoring device constantly monitors temperatures of the whole panel.
- Automated collection and analysis of the temperature data enables to identify a device failure automatically.

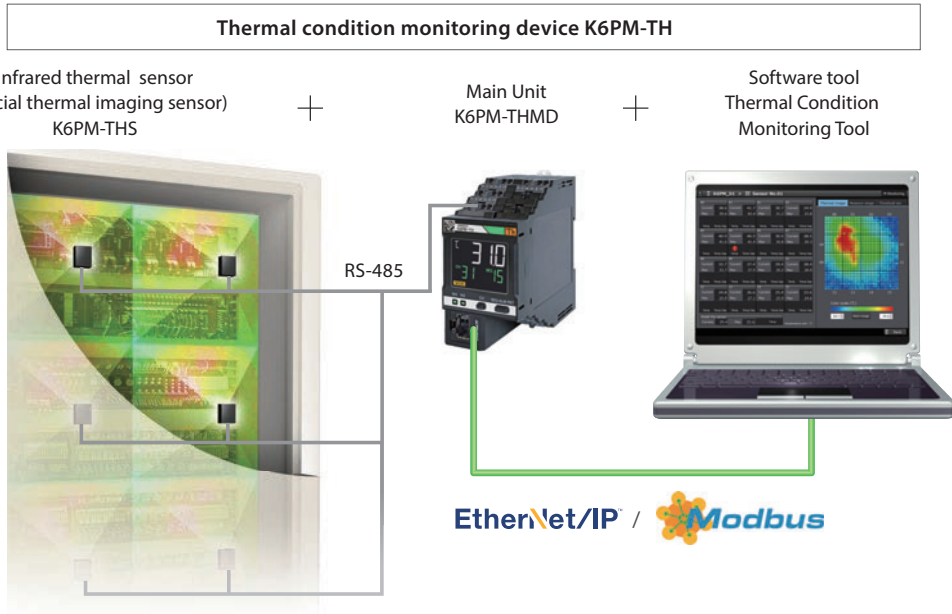

**Measurement applications using K6PM-TH**

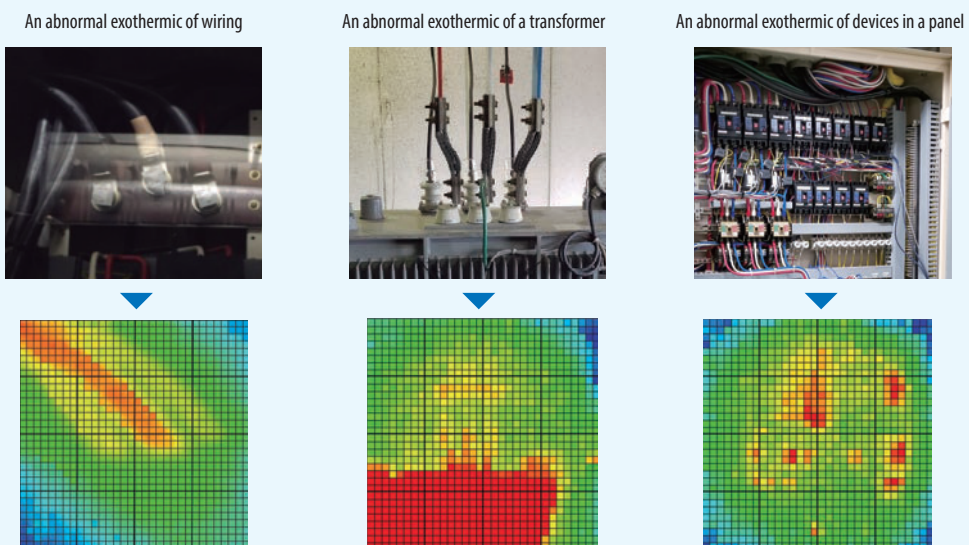

Our shared Value Design for Panel (herein after referred to as "Value Design") concept for the specifications of products used in control panels will create new value to our customer's control panels.

# Visualizing the temperature in a panel accurately without opening the panel door

**Optimal installation regardless of the locations thanks to the wide viewing angle and the compact body.**

## Wide viewing angle lens

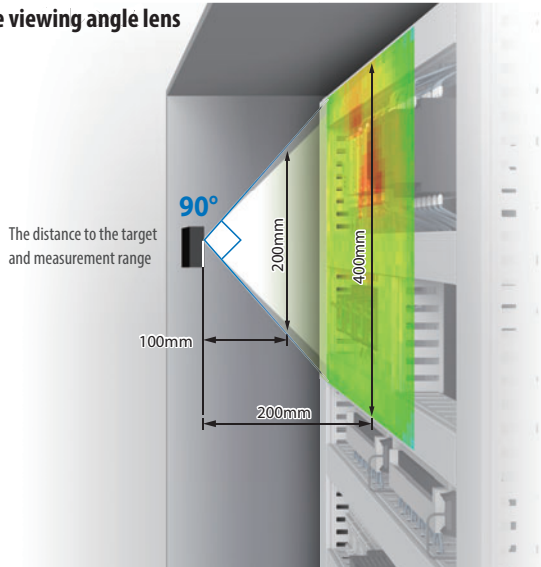

## Compact Infrared temperature sensor (Special thermal Imaging sensor) K6PM-THS

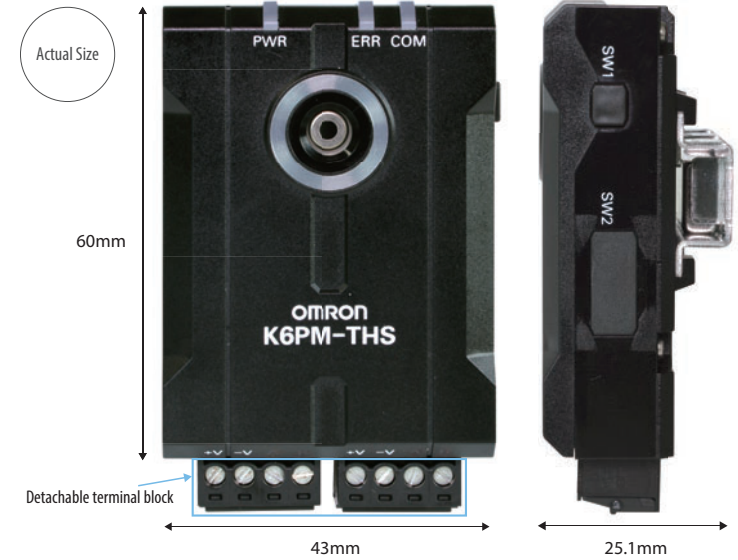

## Environmental resistance

Assuring a normal operation under a harsh environment

Noise	Temperature	Vibration
Conforming to the EMC standard	-10 to 55°C	Vibration:5 G

## Easy mount

Mount with a magnet or a commercially attachment on the backside of the door is available.

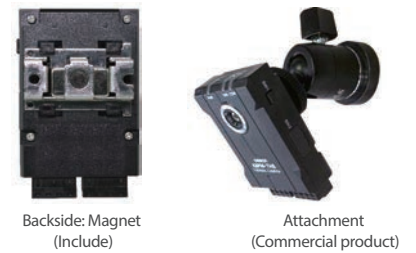

## Identifying an abnormal device by segmenting the thermal image.

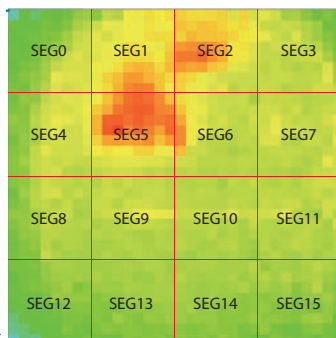

Threshold can be set to each segment of a 16-split thermal image

The resolution of a thermal image is shown as 32 × 32 cells.



**Up to 31 K6PM-THS sensors can be connected with a main unit.**

## Three-step indication for the temperature status



# Contributing to an early detection of abnormality by our proprietary algorithm

## Features 1 Predicting the temperature rise deviations, and notifying the dangerous level of abnormal exothermic.

### Issues on maintenance at sites

Even a stable temperature of the device can lead to a serious abnormality over time depending on the cause of abnormality; however, analysis including history of temperature variation is very difficult with non-continuous temperature monitoring.

### Solution! Arrival prediction algorithm **PATENT PENDING**\*

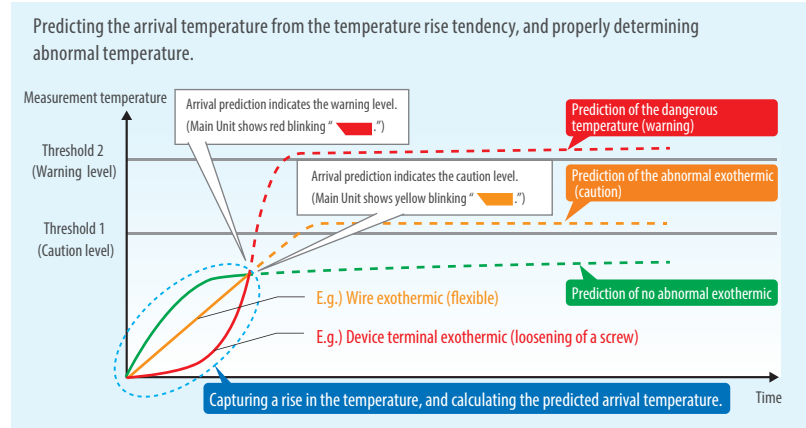

## Features 2 Enable to predict an abnormal exothermic of the devices in an environment where the ambient temperature significantly varies.

### Issues on maintenance at sites

Unable to calculate the accurate temperature variation of a device measured under an environment to be affected by an outside air temperature.

### Solution! Differential temperature detection algorithm **PATENT PENDING**\*

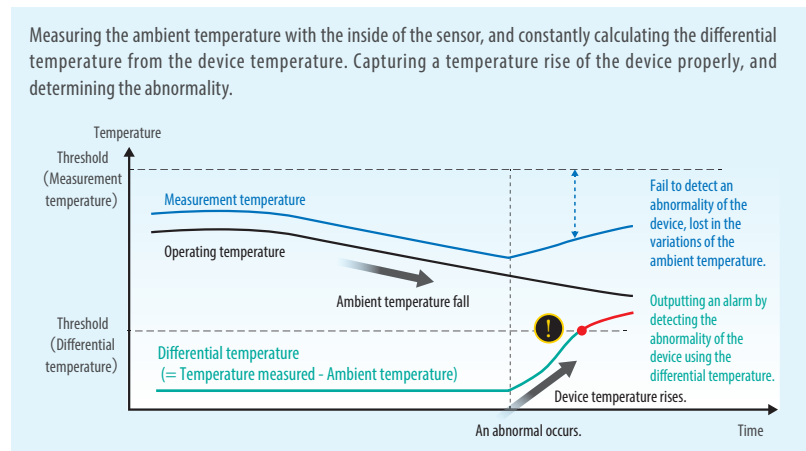

## Features 3 Auto setting of the optimum threshold for the complicated temperature distribution in a panel.

### Issues on maintenance at sites

Inexperienced maintenance engineers do not know the optimum temperature threshold for each device in a panel.

### Solution! Auto threshold set algorithm **PATENT PENDING**\*

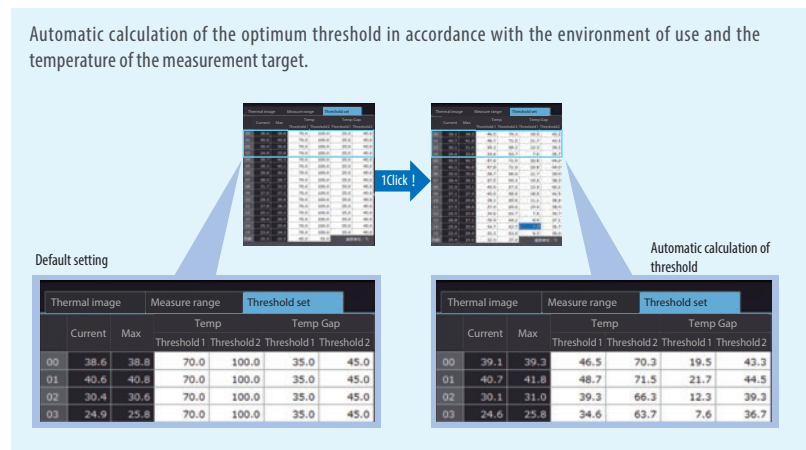

\* As of 2019 May

# System configuration and software tool

"Thermal Condition Monitoring Tool" enables the setting and logging of K6PM-TH. K6PM-TH linked with a PC via an Ethernet cable enables you to recognize the temperature status in panels and warning alarms at one view on a remote PC.

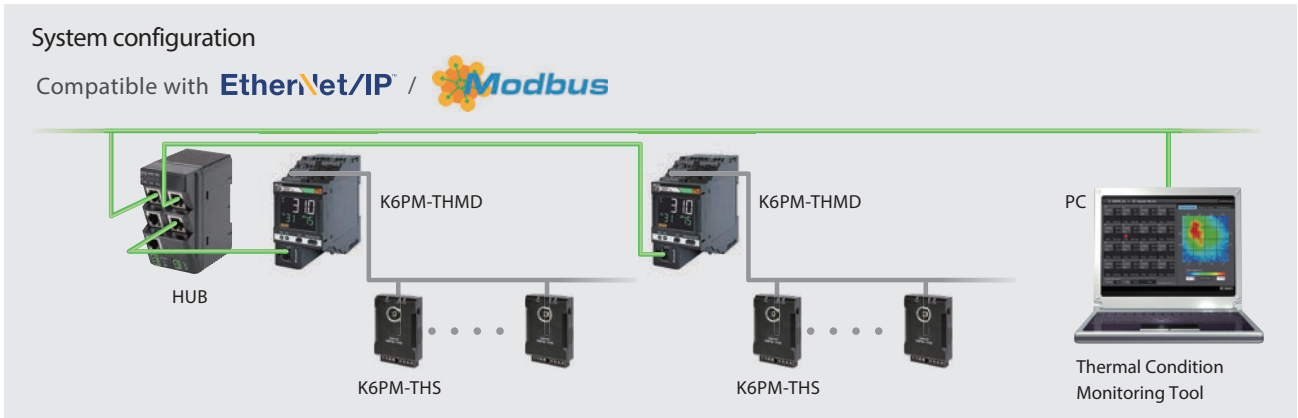

## With Thermal Condition Monitoring Tool you can...

Constantly and remotely visualize the temperature status of the panel in multiple points where K6PM-TH are installed.

Device List of K6PM

No.	Name / IP address	Alarm	Status
01	1G4F Power distribution board 1 192.168.250.30		Monitor
02	1G5F Power Receiving Panel 1	!	Monitor
03	1G4F Power distribution board 2		Monitor
04	1G4F Power distribution board 3	!	Monitor
05	1G4F Power distribution board 4		Monitor

Display the status of the panel via K6PM-TH on the network.  
Up to five K6PM-TH can be connected.

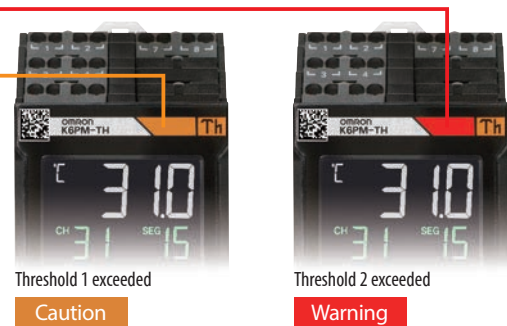

Quickly know the analyzing results of the measurements at one view

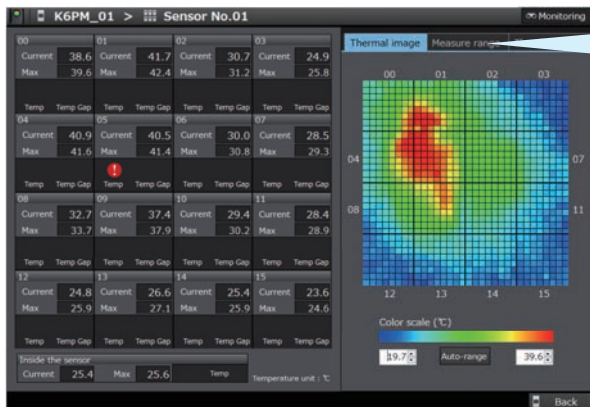

Confirm the temperature status by simultaneously displaying the temperature data and thermal image. Easily identify the device which is outputting an alarm.



Quickly confirm the exothermic part by displaying the measurement image.\*

\* The measurement image should be captured by customers.





# Thermal condition monitoring device

# K6PM-TH

**Consistently and remotely monitor and analysis the temperature status of panel devices to achieve both labor-saving and significant risk mitigation of abnormal stop**



- Visualize the thermal status in a panel using the infrared thermal sensor (Special thermal image sensor) with a wide viewing angle in a compact body, specifically designed for mounting in a panel
- Detect abnormal symptoms by the algorithm analyzing the temperature status in a panel
- Dedicated monitoring tool (Thermal Condition Monitoring Tool) to provide the constant remote monitoring system



For the most recent information on models that have been certified for safety standards, refer to your OMRON website.

## System Configuration

With the software tool, a maximum of five K6PM-THMD devices can be connected via an Ethernet cable, and settings and monitoring can be performed.

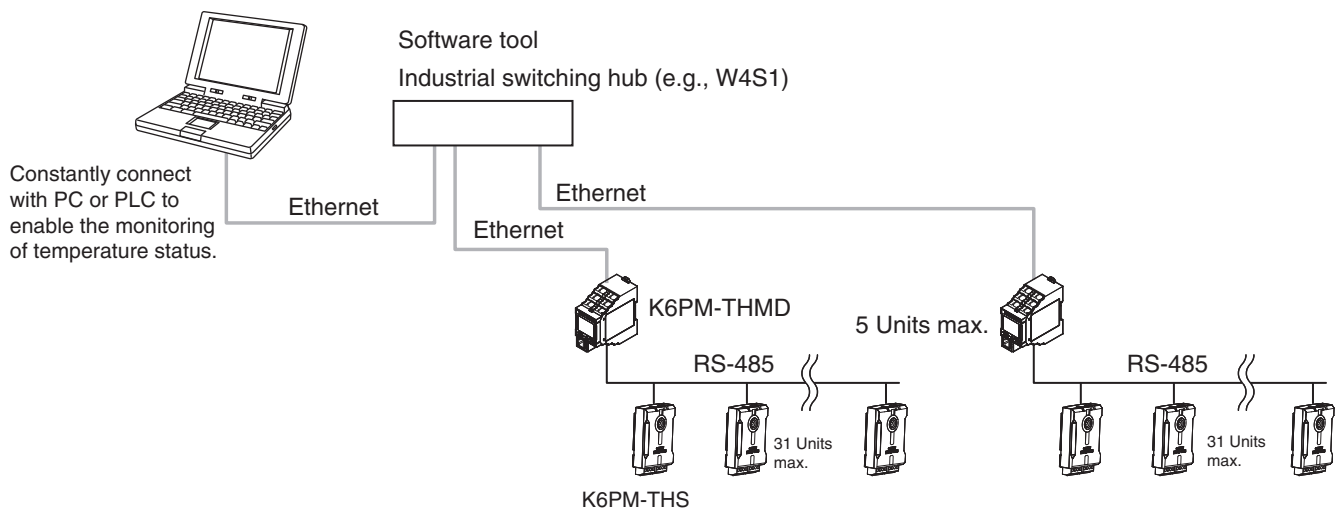

**Note:** Only when setting the IP address, connect the PC and the K6PM-THMD device one to one with an Ethernet cable as shown below.

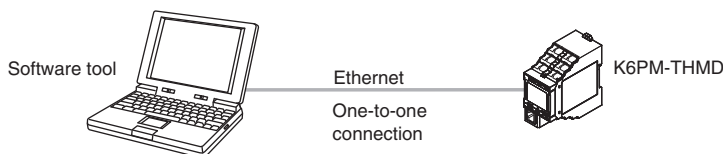



## Model Number Structure

### Model Number Legend

#### Main Unit

**K6PM- TH MD - EIP**  
           (1) (2) (3)

No.	Classification	Symbol	Meaning
(1)	Product classification	TH	Thermal condition monitoring device
(2)	Product classification	MD	Main Unit
(3)	Communications method	EIP	Supports EtherNet/IP and Modbus TCP communications

#### Infrared thermal sensor (Special thermal imaging sensor)

**K6PM- TH S 3232**  
           (1) (2) (3)

No.	Classification	Symbol	Meaning
(1)	Product classification	TH	Thermal condition monitoring device
(2)	Product classification	S	Infrared thermal sensor (Special thermal imaging sensor)
(3)	Model classification	3232	Number of K6PM sensor pixels: 32 × 32

# K6PM-TH

## Ordering Information

### Main Unit

Power supply voltage	Model
24 VCD	K6PM-THMD-EIP



### Infrared thermal sensor

Resolution	Model
32 × 32	K6PM-THS3232

## EtherNet/IP communications cable recommended parts

Use a Category 5 or higher STP cable (shielded twisted pair cable).

### Cable with Connectors

Item	Recommended manufacturer	Cable length (m)	Model
Wire Gauge and Number of Pairs: AWG26, 4-pair Cable Cable Sheath material: LSZH *2 	OMRON	0.3	XS6W-6LSZH8SS30CM-Y
		0.5	XS6W-6LSZH8SS50CM-Y
		1	XS6W-6LSZH8SS100CM-Y
		2	XS6W-6LSZH8SS200CM-Y
		3	XS6W-6LSZH8SS300CM-Y
Wire Gauge and Number of Pairs: AWG22, 2-pair Cable 	OMRON	0.3	XS5W-T421-AMD-K
		0.5	XS5W-T421-BMD-K
		1	XS5W-T421-CMD-K
		2	XS5W-T421-DMD-K
		5	XS5W-T421-GMD-K
		10	XS5W-T421-JMD-K

\*1. Cables with standard RJ45 plugs are available in the following lengths: 0.2 m, 0.3 m, 0.5 m, 1 m, 1.5 m, 2 m, 3 m, 5 m, 7.5 m, 10 m, 15 m, 20 m.  
 Cables with rugged RJ45 plugs are available in the following lengths: 0.3 m, 0.5 m, 1 m, 2 m, 3 m, 5 m, 10 m, 15 m.

For details, refer to the *Industrial Ethernet Connectors Catalog* (Cat. No. G019).

\*2. The lineup features Low Smoke Zero Halogen cables for in-cabinet use and PUR cables for out-of-cabinet use.



\*3. Cable colors are available in yellow, green, and blue. The last character of the model changes to "-G" or "-B".

### Cable/Connector

Part name	Manufacturer	Model
Cable	Hitachi Metals, Ltd.	NETSTAR-C5E SA 0.5 × 4P *
RJ45 connector	Panduit Corporation	MPS588-C *

\* It is recommended to use the cable and connector in combination described above.

### Industrial switching hub (recommended parts)

Recommended manufacturer	Appearance	Specifications			Model
		Function	No. of ports	Failure detection function	
OMRON		Packet priority control (QoS): EtherNet/IP control data priority Failure detection: Broadcast storm, LSI failure detection 10/100BASE-TX, Auto-Negotiation	3	Not possible	W4S1-03B
			5	Not possible	W4S1-05B
			5	Possible	W4S1-05C
Cisco Systems, Inc	Consult the manufacturer. <a href="https://www.cisco.com/">https://www.cisco.com/</a>				
Contec USA, Inc.	Consult the manufacturer. <a href="https://www.contec.com/us/">https://www.contec.com/us/</a>				
Phoenix Contact USA	Consult the manufacturer. <a href="https://www.phoenixcontact.com/online/portal/pc">https://www.phoenixcontact.com/online/portal/pc</a>				



## Ratings and Characteristics

### Main Unit Specifications

#### Ratings

Item	Model	K6PM-THMD-EIP
Power supply	Power supply voltage	24 VDC
	Allowable operating voltage range	85% to 110% of the power supply voltage
	Power supply frequency range	---
	Power consumption	1.6 W max.
Input	Compatible sensor	K6PM-THS3232
	Number of connected K6PM sensors	31 units
Output	Output form	Transistor output
	Number of outputs	3 points:
	Rated voltage	24 VDC
	Maximum current	50 mA
Ambient operating temperature		-10 to +55 °C (with no condensation or freezing)
Ambient storage temperature		-20 to +65 °C (with no condensation or freezing)
Ambient operating humidity		25% to 85% (with no condensation)
Storage humidity		25% to 85% (with no condensation)
Exterior color		Black
Case material		PC UL94-V0
Altitude		2,000 m max.
Applicable wires		Stranded wires, solid wires, or ferrules
Applicable wire size		0.25 to 1.5 mm <sup>2</sup> (AWG24 to AWG16)
Wire insertion force		8 N max. for AWG20 wire
Screwdriver insertion force		15 N max.
Wire stripping length		8 mm *1, 10 mm, 12 mm
Recommended Flat-blade Screwdriver		XW4Z-00B
Current capacity		10 A (per pole)
Number of insertions		50 times
Weight		Approx. 200 g
Mounting *2		DIN Track mounting
		Screw Mounting
Dimensions		45 (W) × 90 (H) × 90 (D) mm
Setting method		Communications settings from software tool
Other functions		Display value selection, Main Unit error and K6PM sensor error output, setting parameters initialization, running time
Accessories		Instruction manual, Software Tool (thermal condition monitoring tool) license number

\*1. Without ferrules

\*2. For details on mounting on a DIN track and screw attachment, refer to *K6PM Thermal Condition Monitoring Device User's Manual* (H231).

# K6PM-TH

## Characteristics

Item		Model	K6PM-THMD-EIP	
Temperature measurement range			The temperature measurement range is described in the thermal sensor (K6PM-THS3232) performance.	
Measurement temperature accuracy			The measurement temperature accuracy is described in the thermal sensor (K6PM-THS3232) performance.	
Sampling cycle for the sensor			Approx. 1 second/Unit	
External trigger	External contact input specifications		Short circuit: Residual voltage 1.5 V or less Open: Leakage current 0.1 mA or less	
	Short circuit current		Approx. 7 mA	
Alarm	Measurement parameters		Current temperature, differential temperature, sensor internal temperature	
	Expression method		Transistor output, alarm bar display	
	Number of variables		Two threshold values per segment (Threshold 1 and Threshold 2)	
	Threshold setting range		0.0 to 999.9°C (0.0 to 999.9°F)	
	Hysteresis		3.0°C width (5.4°F width)	
Resetting method		Manual resetting * or automatic resetting (switching)		
LCD display		7-segment digital displays and individual indicators		
Display resolution		0.1°C		
Applicable standards	Approved standards		UL61010-1 (Listing) installation location: Pollution level 2, South Korean Radio Law	
	Conforming standards		RCM	
	EMC		EN61326-1 (EMI: Class A EMS: Industrial Location)	
Recommended fuse		T2A, time lag, high shut-off capacity		
Insulation resistance		20 MΩ min. Between all external terminals and the case Between all power supply terminals and all other terminals Between all RS-485 communications terminals, and all external trigger input terminals, all transistor output terminals and all Ethernet ports		
Dielectric strength		2,000 VAC for 1 minute Between all external terminals and the case Between all power supply terminals and all other terminals Between all RS-485 communications terminals, and all external trigger input terminals, all transistor output terminals and all Ethernet ports		
Vibration resistance		Frequency: 10 to 55 Hz, 0.35-mm single amplitude in X, Y, and Z directions (10 sweeps of 5 min each)		
Shock resistance		150 m/s <sup>2</sup> , 3 times each in X, Y, and Z axes, 6 directions		
Degree of protection		IP20		
Warranty period		1 year		
Indicators	Alarm bar		Red, yellow, and green	
	MS and NS		Red and green	
Ethernet Communications	Supported services		EtherNet/IP (tag data link or CIP message communications) BOOTP client Modbus TCP	
	Physical layer		100 Base-TX	
	Transmission specifications	Transmission speed		100 Mbps
		Transmission medium		Twisted pair cable (with shield: STP): Category 5 or higher
		Transmission distance		100 m max. (distance between hub and node)
	Tag data link	Class1		Supported.
		Connection resource		4
		Packet interval (RPI)		1,000 to 10,000 ms
		Timeout value		Multiples of RPI (4 times, 8 times, 16 times, 32 times, 64 times, 128 times, 256 times, 512 times)
	Explicit message	Connection type		Point To Point Connection (fixed)
		Class 3		Supported.
		UCMM		Supported.
	Modbus TCP	Number of clients that can communicate at one time with UCMM		2
		Number of clients that can be connected simultaneously		2
	Factory default values	IP address.		192.168.250.30
Subnet mask.		255.255.255.0		
The default gateway.		0.0.0.0		
IP address setting method		Static IP address		

\* Manual resetting method: Press and hold the SEG/ALM RST Button



## Indicator specifications

Symbol	Name	Color	Status	Operating condition
MS	Module Status	Green	Lit.	Normal status
		Red	Lit.	One of the following fatal errors (Main Unit internal error) <ul style="list-style-type: none"> <li>Internal CPU error</li> <li>Internal memory error</li> </ul>
			Flashes at 1-s intervals.	One of the following conditions <ul style="list-style-type: none"> <li>K6PM sensor communications error</li> <li>The detection of the K6PM sensor angle deviation</li> <li>Sensor type error</li> <li>Temperature measurement range exceeded</li> <li>Running time error</li> </ul>
			---	Not lit.
NS	Network Status	Green	Lit.	Tag data link or message connection established
			Flashes at 1-s intervals.	No tag data link or message connection established
		Red	Lit.	IP address duplication status
			Flashes at 1-s intervals.	The connection has timed out, or the BOOTP server connection error state
		---	Not lit.	No power supply

## Transistor output specifications

Name	Description
Transistor Output 1	Threshold 1 excess output of comprehensive alarm. Transistor output type can be set to Normally Closed or Normally Open.
Transistor Output 2	Threshold 2 excess output of comprehensive alarm. Transistor output type can be set to Normally Closed or Normally Open.
Transistor Output 3	Main Unit error and K6PM-TH sensor error output *1 <ul style="list-style-type: none"> <li>Normal: ON</li> <li>Main Unit error and K6PM-TH sensor error: OFF</li> </ul> The output type of transistor output 3 is fixed as Normally closed.

\*1. The Main Unit error and K6PM-TH sensor error specify any one of the following:

- Main Unit internal error (internal CPU error or internal memory error)
- K6PM-TH sensor communications error or sensor type error
- The detection of the K6PM-TH sensor angle deviation
- Temperature measurement range exceeded
- Running time error

\*2. The operation of transistor output 3 is as described below.

	Status		Transistor output 3
	Status of Main Unit	Status of infrared thermal sensor	
Operating			OFF
Main Unit internal error			OFF
In monitoring mode	Before data acquisition	Normal	ON
		K6PM-TH sensor communications error or sensor type error	OFF
	The detection of the K6PM-TH sensor angle deviation		
	Temperature measurement range exceeded		
	Running time error		
K6PM-TH sensor search mode or K6PM-TH sensor position adjustment mode	Before data acquisition	Normal	ON
		K6PM-TH sensor communications error or sensor type error	OFF
	The detection of the K6PM-TH sensor angle deviation		
	Temperature measurement range exceeded		
	Running time error		

## Measured value display

Measurement level	Methods for checking		
	Main Unit (display)	Software tool	Communicaitons
Temperature of each segment and sensor internal temperature	The segment display of each sensor can be switched on the Main Unit front-panel.	Can be checked on the Monitoring sensor screen.	<ul style="list-style-type: none"> <li>• EtherNet/IP tag data link communications</li> <li>• EtherNet/IP message communications</li> <li>• Modbus TCP communications</li> </ul>
Differential temperature per segment from the K6PM-TH sensor internal temperature	Not supported	Not supported	Not supported
Temperature of each infrared thermal sensor	Not supported	The past maximum value can be monitored on the Monitoring K6PM screen.	Not supported
Temperature of each pixel	Not supported	The temperature can be displayed when the cursor is placed on the thermal image on the Monitoring sensor screen.	<ul style="list-style-type: none"> <li>• EtherNet/IP message communications</li> <li>• Modbus TCP communications</li> </ul>
Alarms of each Main Unit (Alarms of all infrared thermal sensors connected to the Main Unit)	The occurrence of an alarm can be checked on the alarm bar.	The occurrence of an alarm can be checked on the Device List of K6PM screen.	The occurrence of an alarm can be checked from the Main Unit status.

## Infrared thermal sensor

### Ratings

Item		Model	K6PM-THS3232
Power supply	Power supply voltage		24 VDC
	Allowable operating voltage range		85% to 110% of the power supply voltage
	Power supply frequency range		---
	Power consumption		0.4 W max./Unit at 24 VDC *1
Ambient operating temperature			-10 to +55 °C (with no condensation or freezing)
Storage temperature			-20 to +65 °C (with no condensation or freezing)
Ambient operating humidity			25% to 85% (with no condensation)
Storage humidity			25% to 85% (with no condensation)
Exterior color			Black
Case material			PC UL94-V0
Altitude			2,000 m max.
Applicable wires			Stranded wires or solid wires
Applicable wire size			0.25 to 1.5 mm <sup>2</sup> (AWG24 to AWG16)
Current capacity			8 A (per pole)
Weight			50 g max.
Mounting			Mounting *2 Screw Mounting
Dimensions			43 × 60 × 25.1 mm (W×H×D) Terminals not included
Accessories *3			Instruction manual, mounting bracket, magnet (for positioning) *4

\*1. The power consumption increases according to the number of connected devices. Take note of the choice of wiring and the wiring diameter.

\*2. A 1/4-20 UNC mounting hole is available (nuts are not provided).

\*3. The pan head is sold separately.

\*4. Use magnet mounting for positioning the sensor.

# K6PM-TH

## Performance

Item		Model	K6PM-THS3232
Temperature measurement	Temperature measurement range		Temperature measurement range: 0.0°C to 200.0°C (32.0°F to 392.0°F)
	Detection resolution		32 × 32 (1,024 pixels)
	Temperature accuracy		±5°C (at an ambient temperature of 25°C) *1*2
	Emissivity		0.94
	Reproducibility		1°C (at an ambient temperature of 25°C) *2
	Temperature drift		0.15°C
	Viewing angle [FOV]		90° × 90°
	Warmup time		15 minutes
Other functions	Over temperature measurement range		Temperature: 200.0°C or higher, sensor internal temperature: 80°C or higher
	Angle deviation detection *3		Angle deviations of 5° (typ) min. and those that continue for 3 seconds min. can be detected.
Output	Communications method		RS-485 communications
	Maximum cable length		500 m
Applicable standards	Approved standards		UL61010-1 (listing) installation location: Pollution degree 2 Korean Radio Waves Act
	Conforming standards		RCM
	EMC		EN61326-1 (EMI: Class A EMS: Industrial Location) Measured temperature fluctuation range: ±6°C
Recommended fuse			T2A, time lag, high shut-off capacity
Insulation resistance			20 MΩ min. Between all terminals and the case
Dielectric strength			1,000 VAC for 1 minute Between all terminals and the case
Vibration resistance			Frequency: 10 to 55 Hz, 0.35-mm single amplitude in X, Y, and Z directions (10 sweeps of 5 min each) *4
Shock resistance			150 m/s <sup>2</sup> , 3 times each in 6 directions along 3 axes *4
Degree of protection			IP20
Indicators	Power indicator		Green (when power is on: lit, when power is not on: off)
	Communications indicator		Orange (when communications are performed: Lit, when communications are not performed: Not lit)
	Alarm indicator		Red (when a sensor error occurs: Lit, when an angle deviation is detected: Flashing)

\*1. Accuracy may vary depending on the measured distance, the object's emissivity, and ambient temperature.

\*2. For details on temperature accuracy and reproducibility, refer to *K6PM Thermal Condition Monitoring Device User's Manual (H231)*.

\*3. Make ON/OFF settings on the DIP switch Pin 2 (default value: OFF).

Since the operation is not stable at a location subject to vibrations, it may not be possible to detect angle deviation.

\*4. During screw mounting



## Software tool

Item		Specification
Project	Number of files that can be created	No limit
Sampling cycle of infrared thermal sensor:	1 to 99	1 to 99 minutes, or 1 to 99 hours (default value: 1 minute)
Logging	Supported file format	Tab-delimited text file format
	Measurement interval	Sampling cycle
	Log file unit	A new file for every 1,440 rows (excluding the header) regardless of the sampling interval
1 Number that can be registered in the project	Number of Main Unit	5 Units max.
Files to create		The following are created in the installation folder \cfg: <ul style="list-style-type: none"> <li>• Project file (INI file format)</li> <li>• Configuration file (INI file format)</li> <li>• The following is created in the installation folder \log: Log file (txt format)</li> </ul> Refer to <i>Details of the File to be Created</i> for details.
Photo image file format that can be read and displayed		JPG/JPEG format
Temperature alarm threshold automatic setting		Supported.

## Details of the file to be created

File type	Extension	Description	Save position by default
Project file	.ini	Text file including the following: <ul style="list-style-type: none"> <li>• Sampling cycle</li> <li>• Device name (of 5 Units max.)</li> <li>• IP address information of Main Unit (of 5 Units max.)</li> <li>• Sensor image display direction (of 31 Units max.)</li> <li>• Sensor color scale setting (of 31 Units max.)</li> <li>• Measurement location image file name (of 31 Units max.)</li> </ul>	C:\Program Files\OMRON\Thermal Condition Monitoring Tool\cfg
Configuration file	.ini	Text file including the following (file name = fixed as "app.ini"): <ul style="list-style-type: none"> <li>• Language</li> </ul>	C:\Program Files\OMRON\Thermal Condition Monitoring Tool\cfg
Log file	.txt	A file is created for each Main Unit. It is text file format, so it can be used by other applications.	The log file location is as follows: C:\Program Files\OMRON\Thermal Condition Monitoring Tool\log\[Main Unit number (2 digits)]

## Operating Environment of the Software tool

Item	Description
OS	Windows 7, Windows 8.1, Windows 10 (32 bit / 64 bit) (JP / EN)
CPU	2.4 GHz or more, 32 bit or 64 bit processor
Memory	4 GB min.
Disk reserved area capacity	64 GB min.
Monitor resolution	1024 × 768 (XGA), High Color 16 bit or more
.NET Framework	.NET Framework 4.7.2 *
Others	LAN port: For network connection

\* The operation requires .NET Framework 4.7.2.

Download the software tool from the OMRON website as follows:  
[https://www.ia.omron.com/k6pm\\_tool](https://www.ia.omron.com/k6pm_tool)

# K6PM-TH

## Connection Diagram

### Main Unit

The diagram below shows the terminal layout of the following:

- 24 VDC
- External trigger input
- Infrared thermal sensor input
- Transistor output 1 to 3

All wiring connections are established by Push-In Plus terminals.

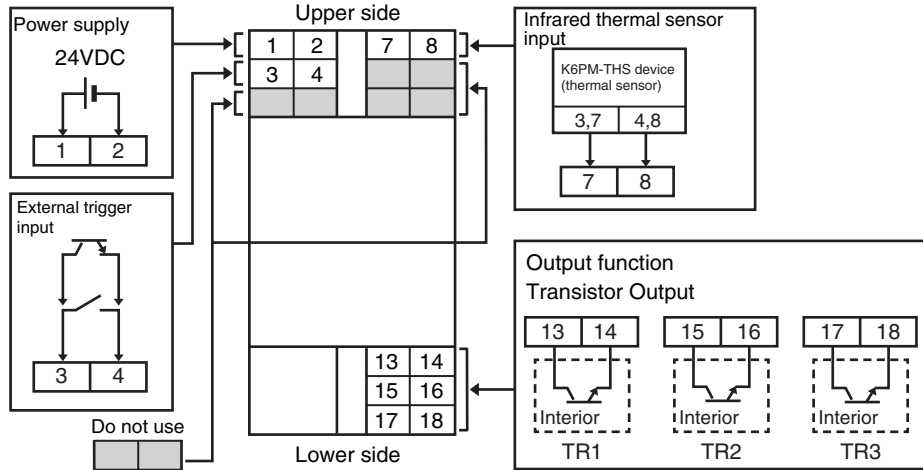

Terminal number	Terminal name	Function
1	Power supply input	24 VDC input terminal (polarity)
2	Power supply input	0 VDC input terminal (polarity)
3 or 4	External trigger input	ON: Interruption of temperature measurement
7	SDB(+)	RS-485 communications terminal (connected with sensor Number 3 or 7)
8	SDA(-)	RS-485 communications terminal (connected with sensor Number 4 or 8)
13 or 14	Transistor Output 1 (TR1)	Temperature error Threshold 1 exceeded
15 or 16	Transistor Output 2 (TR2)	Temperature error Threshold 2 exceeded
17 or 18	Transistor Output 3 (TR3)	Main Unit error and K6PM sensor error

## Infrared thermal sensor

There are two connectors at the bottom of the infrared thermal sensor.  
These two connectors are shorted internally for crossover wiring.

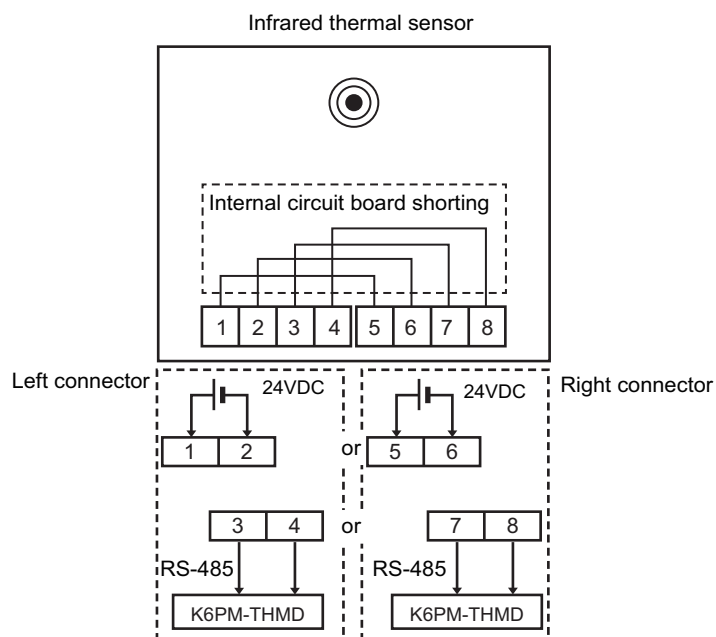

Terminal number	Terminal name	Function
1 or 5	Power supply input (+V)	24 VDC input terminal (polarity)
2 or 6	Power supply input (-V)	0 VDC input terminal (polarity)
3 or 7	RS-485 communications (B)	B (+) RS-485 communications terminal (connected with Main Unit no. 7)
4 or 8	RS-485 communications (A)	A (-) RS-485 communications terminal (connected with Main Unit no. 8)

# K6PM-TH

## Part names and functions

### Main Unit

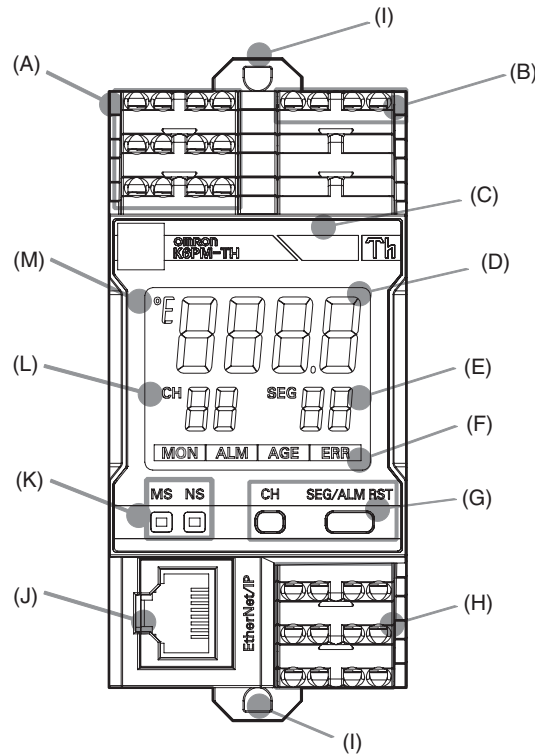

No.	Variable	Function
(A)	Upper terminal	Push-In Plus terminal <ul style="list-style-type: none"> <li>Power supply 24 VDC input to the Main Unit</li> <li>External trigger input</li> <li>ON: Measurement is interrupted.</li> <li>OFF: Measurement is performed.</li> </ul>
(B)	Upper terminal	Push-In Plus terminal <ul style="list-style-type: none"> <li>Infrared thermal sensor input (RS-485 communications)</li> </ul>
(C)	Alarm bar	Displays the following states of the Main Unit. <ul style="list-style-type: none"> <li>Normal (no alarm has occurred): Lit green</li> <li>No operation is being performed (power supply is not connected): Not lit</li> <li>Search or position adjustment mode: Not lit</li> <li>An alarm has occurred <ul style="list-style-type: none"> <li>Current temperature / differential temperature over threshold 1: Lights yellow</li> <li>Current temperature / differential temperature over threshold 2: Lights red</li> </ul> </li> <li>When the arrival prediction function is enabled: *</li> </ul>
(D)	Numeric LCD display	Depending on the operating mode, the display differs as shown below. <ul style="list-style-type: none"> <li>Monitoring mode: Current temperature of the selected segment of the selected sensor <ol style="list-style-type: none"> <li>When communications are not established with the sensor: " - - - - " is displayed</li> <li>When a K6PM sensor communications error occurs: "SErr" is displayed</li> <li>When the sensor temperature exceeds the measurement range: The current temperature flashes</li> <li>During measurement interruption due to an external trigger: The display is fixed as the value immediately before interruption</li> <li>K6PM sensor search mode: "a" is displayed for a sensor that sends a response, and "aFF" is displayed for a sensor that sends no response</li> </ol> </li> <li>K6PM sensor position adjustment mode: "Rd" is displayed</li> <li>When a Main Unit internal error occurs: "8888" flashes</li> </ul>
(E)	SEG	The segment number or the number of currently-connected infrared thermal sensors is displayed. Depending on the operating mode, the display differs as shown below. <ul style="list-style-type: none"> <li>In monitoring mode: The segment number selected by the SEG/ALM RST Key is displayed. 0 to 15 Sensor internal temperature: 99</li> <li>In sensor search mode: The number of infrared thermal sensors currently connected to the Main Unit is displayed.</li> <li>In sensor position adjustment mode: The number of infrared thermal sensors currently connected to the Main Unit is displayed.</li> </ul>
(F)	Status display	The status of the Main Unit is displayed as follows: <ul style="list-style-type: none"> <li>MON: K6PM sensor monitoring state. The indicator is not lit during measurement interruption due to an external trigger.</li> <li>ALM: Alarm occurrence state (lit only when the corresponding K6PM sensor number is being displayed)</li> <li>AGE: Running time reaches 100%</li> <li>ERR: Main Unit internal error</li> </ul>
(G)	Operation Keys	CH Key: Switching of sensor number SEG/ALM RST Key pressed for less than 5 seconds: Switching of segment number SEG/ALM RST Key pressed and held (5 seconds min.): Alarm latch released (Can be performed only by this operation. The latch cannot be released by the software tool and communications.) CH Key and SEG/ALM RST Key simultaneously pressed and held (5 seconds min.): Initialization (Operation returns to the factory state.)
(H)	Lower terminal	Connection is established by the Push-In Plus terminal. <ul style="list-style-type: none"> <li>Transistor output 1 to 3</li> </ul> For details, refer to <i>Transistor output</i> .



No.	Variable	Function
(I)	DIN Track mounting hook	Used for mounting to the DIN Track.
(J)	Communications connector	Connects the communications cable of the EtherNet/IP network.
(K)	Indicators	Indicates the product status or network status by LEDs. <ul style="list-style-type: none"> <li>• "MS": Module Status. Displays the status of the Main Unit. It is green when it is normal.</li> <li>• "NS": Network Status. Displays the state of the communications. It lights or flashes green when it is normal.</li> </ul> For details, refer to <i>Indicator specifications</i> .
(L)	Words	Indicates the K6PM sensor number. 1 to 31
(M)	°E Temperature units	Displays the temperature unit. °C or °F.

\* The display is as follows when the arrival prediction function is enabled.

- The predicted arrival temperature exceeds threshold 1, and the current temperature or differential temperature does not exceed the threshold: Flashes yellow
- Regardless of whether the predicted arrival temperature exceeds threshold 1, the current temperature or differential temperature exceeds threshold 1: Lit in yellow
- Regardless of whether the current temperature or differential temperature exceeds threshold 1, the predicted arrival temperature exceeds threshold 2: Flashes red
- Regardless of whether the predicted arrival temperature exceeds the threshold, the current temperature or differential temperature exceeds threshold 2: Lit in red

## Indicator specifications

Symbol	Name	Color	Status	Operating condition
MS	Product and network status indications (Module Status)	Green	Lit.	Normal status
			Flashes at 1-s intervals.	BOOTP server connection error state
		Red	Lit.	One of the following fatal errors (Main Unit internal error) <ul style="list-style-type: none"> <li>• Internal CPU error</li> <li>• Internal memory error</li> </ul>
			Flashes at 1-s intervals.	One of the following conditions <ul style="list-style-type: none"> <li>• K6PM sensor communications error</li> <li>• The detection of the K6PM sensor angle deviation</li> <li>• Sensor type error</li> <li>• Temperature measurement range exceeded</li> <li>• Running time error</li> </ul>
--	Not lit.	No power supply		
NS	Network status indication (Network Status)	Green	Lit.	Tag data link or message connection established
			Flashes at 1-s intervals.	No tag data link or message connection established
		Red	Lit.	IP address duplication status
			Flashes at 1-s intervals.	Connection timed out
--	Not lit.	No power, or IP address is not set		

## Transistor output

Name	Description
Transistor Output 1	Threshold 1 excess output of comprehensive alarm. Transistor output type can be set to Normally Closed or Normally Open.
Transistor Output 2	Threshold 2 excess output of comprehensive alarm. Transistor output type can be set to Normally Closed or Normally Open.
Transistor Output 3	Main Unit error and K6PM sensor error output <ul style="list-style-type: none"> <li>• Normal: ON</li> <li>• Main Unit error and K6PM sensor error: OFF</li> </ul> <b>Note:</b> <ol style="list-style-type: none"> <li>1. The Main Unit error and K6PM sensor error specify any one of the following: <ul style="list-style-type: none"> <li>• Main Unit internal error (internal CPU error or internal memory error)</li> <li>• K6PM sensor communications error or sensor type error</li> <li>• The detection of the K6PM sensor angle deviation</li> <li>• Temperature measurement range exceeded</li> <li>• Running time error</li> </ul> </li> <li>2. The output type of transistor 3 is fixed as Normally closed.</li> </ol>

## Infrared thermal sensor

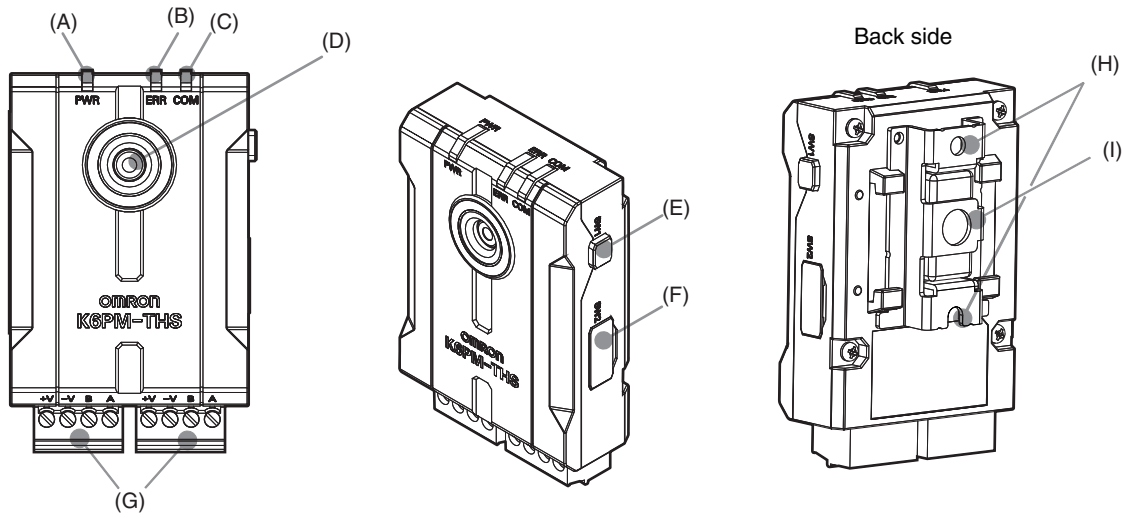

No.	Variable	Function
(A)	Power indicator (Green)	Lit when power is turned ON
(B)	Alarm indicator (Red)	<ul style="list-style-type: none"> <li>Lit in red: Measurement temperature or internal temperature over</li> <li>Flashing red: K6PM sensor angle deviation occurs</li> </ul>
(C)	Communications indicator (orange)	<ul style="list-style-type: none"> <li>Communications: Lit</li> <li>Standby: Not lit (stopped)</li> </ul>
(D)	Thermal sensor lens	----
(E)	Reset switch for the K6PM sensor angle deviation	Resets the sensor internal angle deviation occurrence flag.
(F)	DIP switches	*
(G)	Connector-Terminal Block Conversion Unit	For Power supply and the RS-485 wiring
(H)	Screw hole for fixing mounting bracket	For direct sheet metal attachment
(I)	Connector-Terminal Block Conversion Unit	1/4-20 UNC thread compatible

\* The setting contents of the DIP switch pin are as follows:

SW	Setting contents	Value
1 to 5	K6PM sensor number setting	Set in binary with ON as 1 and OFF as 0 (Pin 1: Least significant bit, Pin 5: Most significant bit) 00001 to 11111: K6PM sensor number 1 to 31 00000: Not used. Factory default: 00001
6	RS-485 terminating resistance	OFF: Without terminating resistance (factory default) ON: With terminating resistance
7	The detection of the K6PM sensor angle deviation	OFF: No detection (factory default) ON: With detection
8	Reserved	----

## Installation of the Infrared thermal sensor

Install the infrared thermal sensor at the back of the panel door, or on the internal side surface of the panel.

The infrared thermal sensor can be installed either directly on the panel, or can be installed by using a commercially available pan head.

- Installing on the back of the panel door either directly or by using a commercially available pan head

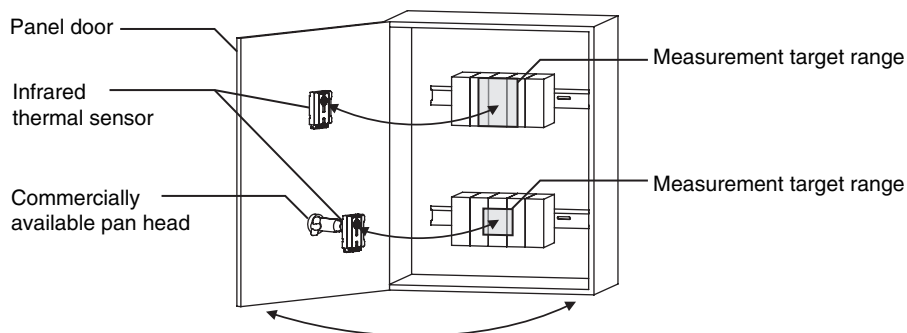

- Installing on the internal side surface of the panel by using a commercially available pan head

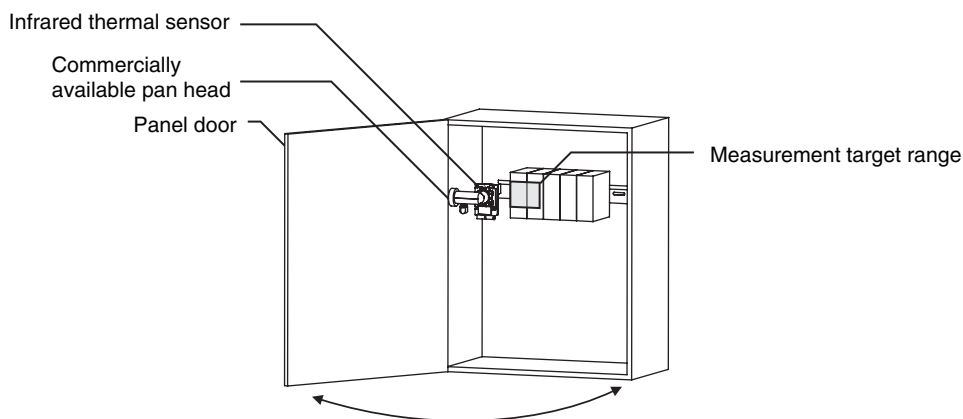

# K6PM-TH

## Dimensions

(Unit: mm)

### Main Unit

K6PM-THMD-EIP

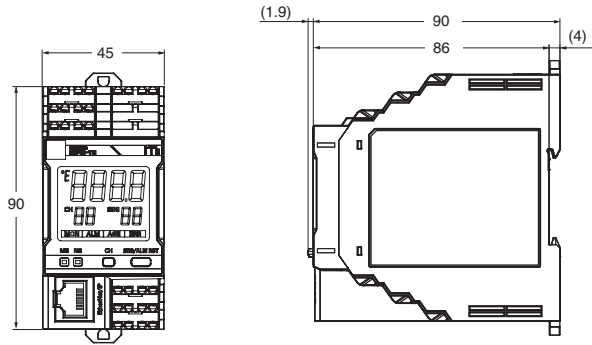

### Infrared thermal sensor

K6PM-THS3232

With Mounting Bracket Attached

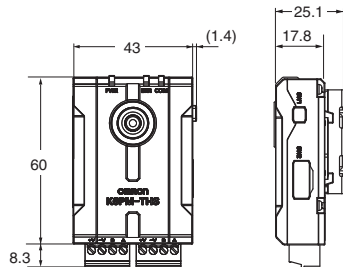

Windows is either a registered trademark or trademark of Microsoft Corporation in the United States and/or other countries.

EtherNet/IP™ is the trademarks of ODVA.

Modbus is a registered trademark of Schneider Electric.

Other company names and product names in this document are the trademarks or registered trademarks of their respective companies.

Some images are used under license from Shutterstock.com.



# Terms and Conditions Agreement

## **Read and understand this catalog.**

Please read and understand this catalog before purchasing the products. Please consult your OMRON representative if you have any questions or comments.

## **Warranties.**

- (a) Exclusive Warranty. Omron's exclusive warranty is that the Products will be free from defects in materials and workmanship for a period of twelve months from the date of sale by Omron (or such other period expressed in writing by Omron). Omron disclaims all other warranties, express or implied.
- (b) Limitations. OMRON MAKES NO WARRANTY OR REPRESENTATION, EXPRESS OR IMPLIED, ABOUT NON-INFRINGEMENT, MERCHANTABILITY OR FITNESS FOR A PARTICULAR PURPOSE OF THE PRODUCTS. BUYER ACKNOWLEDGES THAT IT ALONE HAS DETERMINED THAT THE PRODUCTS WILL SUITABLY MEET THE REQUIREMENTS OF THEIR INTENDED USE.

Omron further disclaims all warranties and responsibility of any type for claims or expenses based on infringement by the Products or otherwise of any intellectual property right. (c) Buyer Remedy. Omron's sole obligation hereunder shall be, at Omron's election, to (i) replace (in the form originally shipped with Buyer responsible for labor charges for removal or replacement thereof) the non-complying Product, (ii) repair the non-complying Product, or (iii) repay or credit Buyer an amount equal to the purchase price of the non-complying Product; provided that in no event shall Omron be responsible for warranty, repair, indemnity or any other claims or expenses regarding the Products unless Omron's analysis confirms that the Products were properly handled, stored, installed and maintained and not subject to contamination, abuse, misuse or inappropriate modification. Return of any Products by Buyer must be approved in writing by Omron before shipment. Omron Companies shall not be liable for the suitability or unsuitability or the results from the use of Products in combination with any electrical or electronic components, circuits, system assemblies or any other materials or substances or environments. Any advice, recommendations or information given orally or in writing, are not to be construed as an amendment or addition to the above warranty.

See <http://www.omron.com/global/> or contact your Omron representative for published information.

## **Limitation on Liability; Etc.**

OMRON COMPANIES SHALL NOT BE LIABLE FOR SPECIAL, INDIRECT, INCIDENTAL, OR CONSEQUENTIAL DAMAGES, LOSS OF PROFITS OR PRODUCTION OR COMMERCIAL LOSS IN ANY WAY CONNECTED WITH THE PRODUCTS, WHETHER SUCH CLAIM IS BASED IN CONTRACT, WARRANTY, NEGLIGENCE OR STRICT LIABILITY.

Further, in no event shall liability of Omron Companies exceed the individual price of the Product on which liability is asserted.

## **Suitability of Use.**

Omron Companies shall not be responsible for conformity with any standards, codes or regulations which apply to the combination of the Product in the Buyer's application or use of the Product. At Buyer's request, Omron will provide applicable third party certification documents identifying ratings and limitations of use which apply to the Product. This information by itself is not sufficient for a complete determination of the suitability of the Product in combination with the end product, machine, system, or other application or use. Buyer shall be solely responsible for determining appropriateness of the particular Product with respect to Buyer's application, product or system. Buyer shall take application responsibility in all cases.

NEVER USE THE PRODUCT FOR AN APPLICATION INVOLVING SERIOUS RISK TO LIFE OR PROPERTY OR IN LARGE QUANTITIES WITHOUT ENSURING THAT THE SYSTEM AS A WHOLE HAS BEEN DESIGNED TO ADDRESS THE RISKS, AND THAT THE OMRON PRODUCT(S) IS PROPERLY RATED AND INSTALLED FOR THE INTENDED USE WITHIN THE OVERALL EQUIPMENT OR SYSTEM.

## **Programmable Products.**

Omron Companies shall not be responsible for the user's programming of a programmable Product, or any consequence thereof.

## **Performance Data.**

Data presented in Omron Company websites, catalogs and other materials is provided as a guide for the user in determining suitability and does not constitute a warranty. It may represent the result of Omron's test conditions, and the user must correlate it to actual application requirements. Actual performance is subject to the Omron's Warranty and Limitations of Liability.

## **Change in Specifications.**

Product specifications and accessories may be changed at any time based on improvements and other reasons. It is our practice to change part numbers when published ratings or features are changed, or when significant construction changes are made. However, some specifications of the Product may be changed without any notice. When in doubt, special part numbers may be assigned to fix or establish key specifications for your application. Please consult with your Omron's representative at any time to confirm actual specifications of purchased Product.

## **Errors and Omissions.**

Information presented by Omron Companies has been checked and is believed to be accurate; however, no responsibility is assumed for clerical, typographical or proofreading errors or omissions.

**OMRON Corporation Industrial Automation Company**

Kyoto, JAPAN

Contact: [www.ia.omron.com](http://www.ia.omron.com)

**Regional Headquarters**

**OMRON EUROPE B.V.**

Wegalaan 67-69, 2132 JD Hoofddorp  
The Netherlands  
Tel: (31)2356-81-300/Fax: (31)2356-81-388

**OMRON ELECTRONICS LLC**

2895 Greenspoint Parkway, Suite 200  
Hoffman Estates, IL 60169 U.S.A.  
Tel: (1) 847-843-7900/Fax: (1) 847-843-7787

**OMRON ASIA PACIFIC PTE. LTD.**

No. 438A Alexandra Road # 05-05/08 (Lobby 2),  
Alexandra Technopark,  
Singapore 119967  
Tel: (65) 6835-3011/Fax: (65) 6835-2711

**OMRON (CHINA) CO., LTD.**

Room 2211, Bank of China Tower,  
200 Yin Cheng Zhong Road,  
PuDong New Area, Shanghai, 200120, China  
Tel: (86) 21-5037-2222/Fax: (86) 21-5037-2200

**Authorized Distributor:**

© OMRON Corporation 2019 All Rights Reserved.  
In the interest of product improvement,  
specifications are subject to change without notice.

**CSM\_1\_1\_0519**  
Cat. No. H232-E1-01

0519(0519)