

Cam Positioner

H8PR

Low-Cost, High-Performance Electronic Cam Switch for Use with OMRON E6F Absolute Rotary Encoder

- Control outputs can be programmed to turn ON/OFF in 1° units of rotary encoder shaft rotation
- Handles input from the dedicated E6F-AB3C-C Absolute Rotary Encoder
- A single control output can be programmed to turn ON/OFF up to 10 times
- Quick response of 0.2 ms (5 kHz) max.
- The encoder shaft rotation direction can be changed and the point of origin automatically corrected
- Built-in battery backs up program memory



Ordering Information

Cam Positioner

Programmable control outputs	8 points		16 points		24 points	
	NPN	PNP	NPN	PNP	NPN	PNP
Model	H8PR-8	H8PR-8P	H8PR-16	H8PR-16P	H8PR-24	H8PR-24P

Absolute Encoder

Model	E6F-AB3C-C
Cable length	2 m

Encoder Shaft Connector

Model	E69-C10B
-------	----------

- Note:**
1. An optional 5-m Extension Cable, E69-DF5, is available.
 2. The cable can be extended up to 30 m.
 3. The *H8PR Operation Manual* is also available.

Specifications

■ Ratings

Supply voltage		100 to 240 VAC, 50/60 Hz
Operating voltage range		90 to 110% of rated supply voltage
Power consumption		Approx. 10 W (240 VAC, 50 Hz)
Input	Encoder input	Accepts input from E6F-AB3C-C Rotary Encoder Response time: 5 kHz (0.2 ms) at 833 rpm of encoder shaft. Adjustable to 0.5, 1, 2, 3, 4, and 5 kHz With built-in error detection function
	INHIBIT	Input via contacts or transistor (selectable) and turns OFF all control outputs Contact input: 20 ms response time Solid-state input: 5 ms response time
	FORCED RUN	Input when FORCED RUN and 0 V (or-COM) terminals are short-circuited and protects program from being modified.
Output	Open-collector transistor output 30 VDC, 100 mA max. NPN: H8PR-8/16/24 PNP: H8PR-8P/16P/24P	
	Control outputs	No. of points: 8 (OUT 1 to OUT 8) for H8PR-8(P) 16 (OUT 1 to OUT 16) for H8PR-16(P) 24 (OUT 1 to OUT 24) for H8PR-24(P)
	RUN	Turns ON in RUN mode and OFF in case of error

■ Characteristics

Controllable Encoder shaft rotation angle	Can be set in units of 1°. One control output can be programmed to turn ON/OFF up to 10 times.	
Encoder rotation	Clockwise/counterclockwise (selectable)	
Encoder origin compensation	-179° to +180°	
Teaching function	Angles at which control outputs are to be turned ON/OFF and point of origin can be registered in memory directly from Encoder	
Output starting angle	0° to 359°	
Memory protection function against power failure	0.01 s	
Memory protection	10 years min. (at 25°C)	
Insulation resistance	100 MΩ min. at 500 VDC between current-carrying terminals and non-current-carrying exposed metal parts, and between power circuit and control output circuit	
Dielectric strength	1,500 VAC, 50/60 kHz for 1 minute between current-carrying terminals and non-current-carrying exposed metal parts, and between power circuit and control output circuit.	
Vibration resistance	Destruction: 10 to 55 Hz, 0.75 mm double amplitude Malfunction: 10 to 55 Hz, 0.5 mm double amplitude	
Shock resistance	Destruction: 300 m/s ² (approx. 30 G) Malfunction: 100 m/s ² (approx. 10 G)	
Ambient operating temperature	-10°C to 55°C	
Ambient humidity	35% to 85%	
EMC	(EMI): Emission Enclosure: Emission AC Mains: (EMS): Immunity ESD: Immunity RF-interference: Immunity Conducted Disturbance: Immunity Burst:	EN50081-2 EN55011 Group 1 class A EN55011 Group 1 class A EN50082-2 EN61000-4-2:4 kV contact discharge 8 kV air discharge ENV50140: 10 V/m (Amplitude-modulated, 80 MHz to 1 GHz) 10 V/m (Pulse-modulated, 900 MHz) ENV50141: 10 V (0.15 to 80 MHz) EN61000-4-4:2 kV power-line 2 kV I/O signal-line
Approved standards	UL508, CSA C22.2 No.14, conforms to EN61010-1/IEC61010-1, EN50081-2, and EN50082-2	
Weight	Approx. 1.3 kg	

Output Response Time

Response frequency of Encoder	Output response time
5 kHz, 4 kHz	0.3 ms max.
3 kHz	0.35 ms max.
2 kHz	0.5 ms max.
1 kHz	1.1 ms max.
0.5 kHz	1.5 ms max.

Dimensions

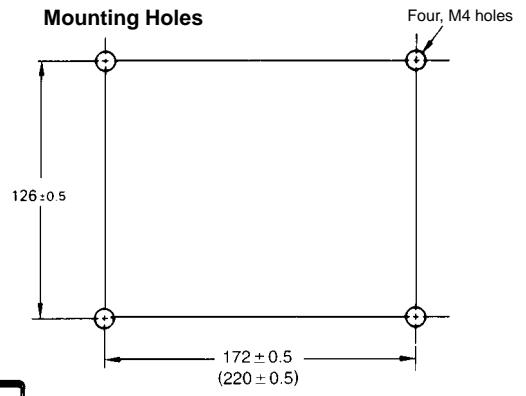
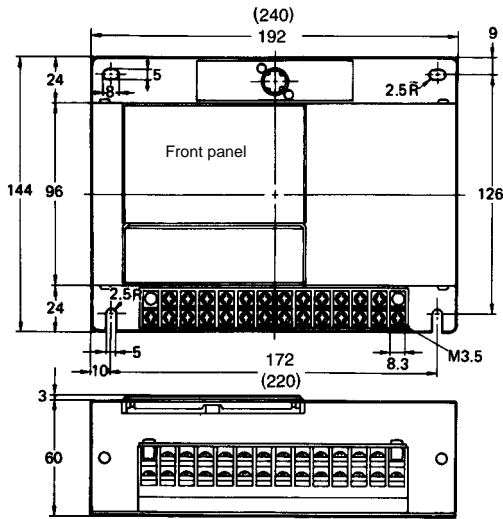

The figure in parentheses applies to the H8PR-24(P).

Nomenclature

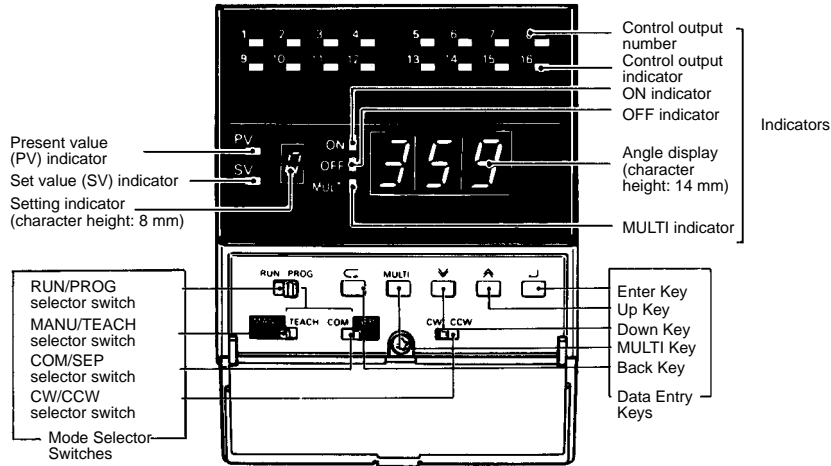

Operation

The H8PR Cam Positioner accepts rotation angle signal input from the OMRON E6F-AB3C-C Absolute Rotary Encoder which indicates the rotation angle of the Encoder shaft. Each control output of

the Cam Positioner can be programmed to turn ON or OFF at fixed angle of the Encoder shaft.

Program Example

Step ON/OFF output	0		1		2		to ...	9	
	ON	OFF	ON	OFF	ON	OFF		ON	OFF
1	45°	90°	180°	315°	---	---	...	---	---
2	90°	180°	225°	270°	315°	18°	...	---	---
3	44°	45°	135°	220°	225°	340°	...	---	---
to
16	0°	18°	36°	54°	72°	90°	...	324°	342°

Operation Example

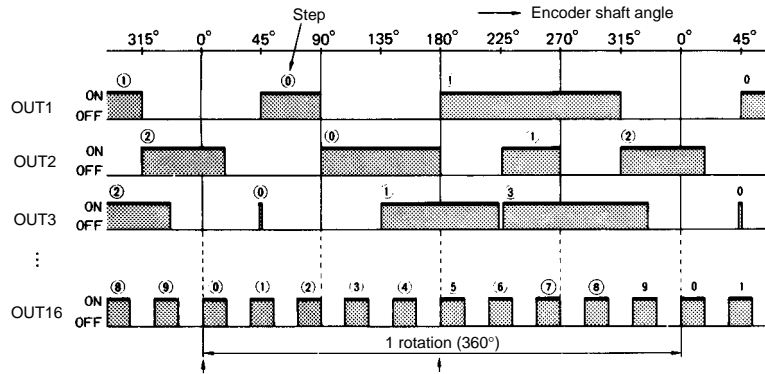

Can be programmed from 0°. One control output can be programmed to turn ON/OFF up to 10 times.

Connections

Encoder Input Connection

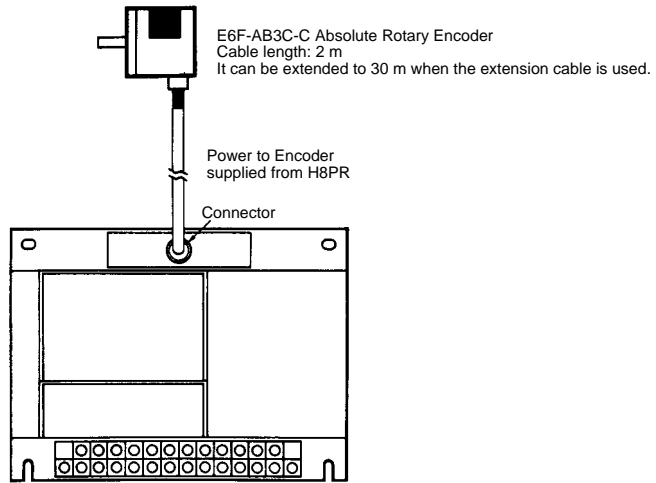

Input Terminal Arrangement H8PR-8/16

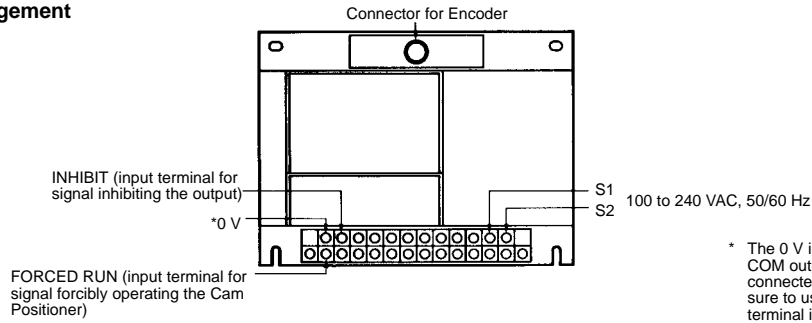

* The 0 V input terminal and the COM output terminal are connected internally; however, be sure to use 0 V as the common terminal in the input circuit.

H8PR-24

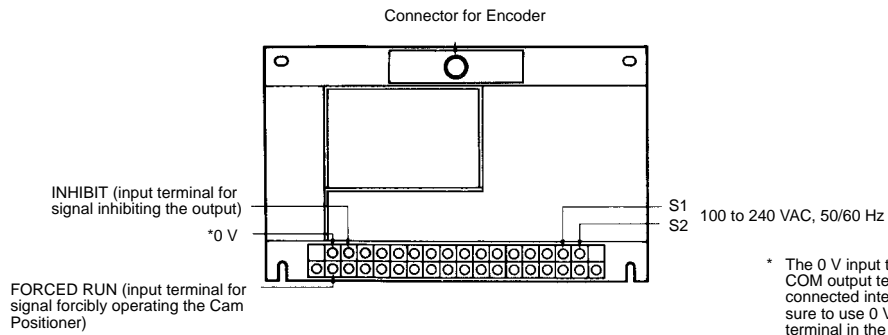

* The 0 V input terminal and the COM output terminal are connected internally; however, be sure to use 0 V as the common terminal in the input circuit.

H8PR-8P/16P

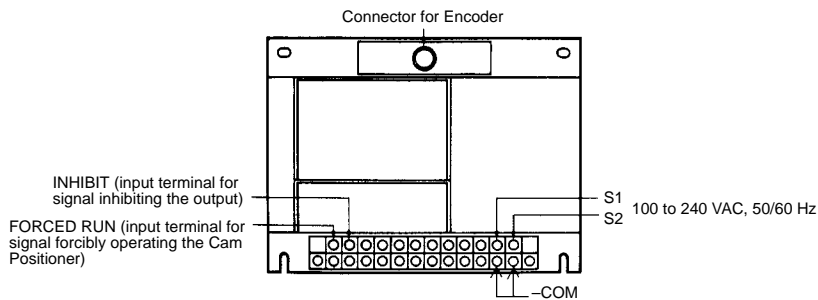

H8PR-24P

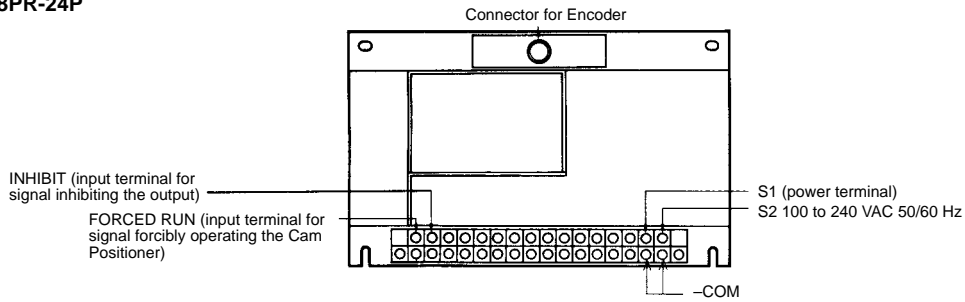

Output Terminal Arrangement

H8PR-8/16

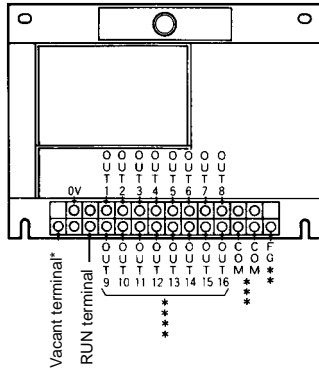

H8PR-8/16

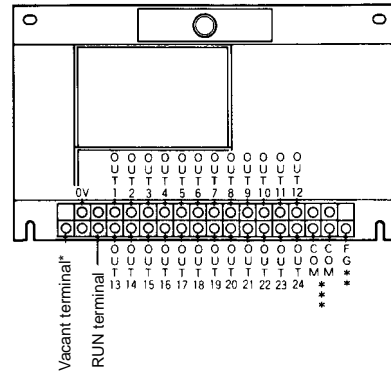

- * Do not use the vacant terminal as a repeating terminal.
- ** Be sure to ground this terminal to prevent electric shock.
- *** The COM output terminal and the 0 V input terminal are internally connected; however, be sure to use COM terminal as the common terminal for output circuits.
- **** Terminals OUT9 to OUT16 are not provided on the H8PR-8.

H8PR-8P/16P

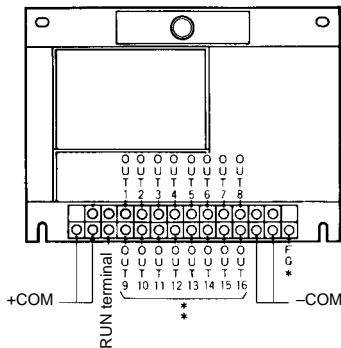

H8PR-24P

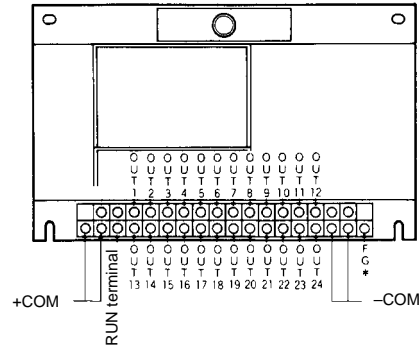

- * Be sure to ground this terminal to prevent electric shock.
- ** Terminals OUT9 to OUT16 are not provided on the H8PR-8.

**Connecting to Programmable Controller
H8PR-8/16/24**

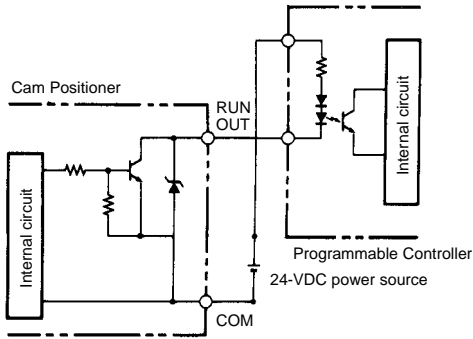

H8PR-8P/16P/24P

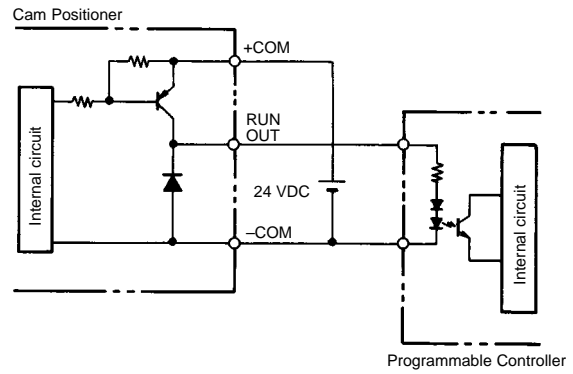

Note: Supply the power to the sensor for INHIBIT signal input and output circuit from the same power source.

H8PR-8/16/24

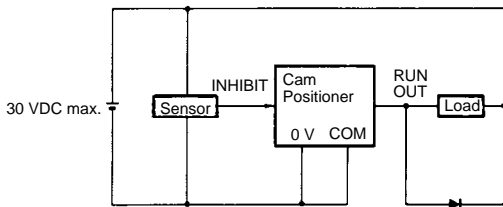

H8PR-8P/16P/24P

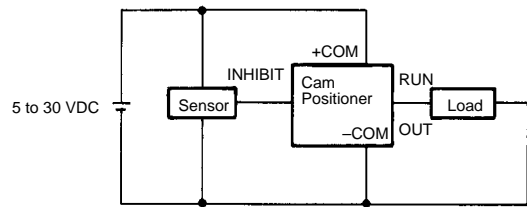

E6F Rotary Encoder (Absolute Type)

- Resolution of 360 allows detection in units of 1°
- 10 mm dia. rigid shaft withstands loads of up to 10 kg (radial) and 3 kg (axial)
- Drip-proof, oil-proof construction (meets IP52F) permits versatile use in adverse environments

E6F-AB3C-C

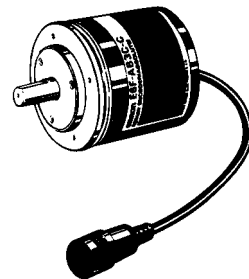

■ Specifications

Supply voltage	5 to 12 VDC, -5%, +10%, contains 5% ripple (p-p) max.
Current consumption	100 mA max.
Sensing method	Absolute type
Resolution (pulse/revolution)	360 (10 bits)
Output code	BCD
Output configuration	Open-collector transistor output
Output capacity	Applied voltage: 30 VDC max. Sink current: 35 mA max. Residual voltage: 0.4 V max. (at 35 mA sink current)
Maximum response frequency	10 kHz
Logic	Negative (H level: 0, L level: 1)
Accuracy	±0.5° max.
Revolution direction	Output code increased in clockwise direction (when viewed from shaft)
Output rise and fall times	1.0 μs max. (control output voltage: 5 V, load resistance: 470 Ω, output cable: 2 m) 2.0 μs max. (control output voltage: 5 V, load resistance: 1 kΩ, output cable: 2 m)
Starting torque	100 gf-cm max.
Moment of inertia	15 g-cm ² max.
Shaft loading	Radial: 10 kgf, Axial: 3 kgf
Maximum rpm	5,000 rpm
Ambient temperature	Operating: -10°C to 70°C Storage: -25°C to 80°C
Ambient humidity	35% to 85% (without condensation)
Vibration resistance	Destruction: 10 to 55 Hz, 1.5 mm double amplitude (in X, Y, and Z directions, respectively for 2 hours)
Shock resistance	Destruction: 100 G (in X, Y, Z directions, respectively 3 times)
Degree of protection	IEC IP52F (dust-proof, drop-proof)
Weight	Approx. 500 g (including 2 m cable)

■ Dimensions

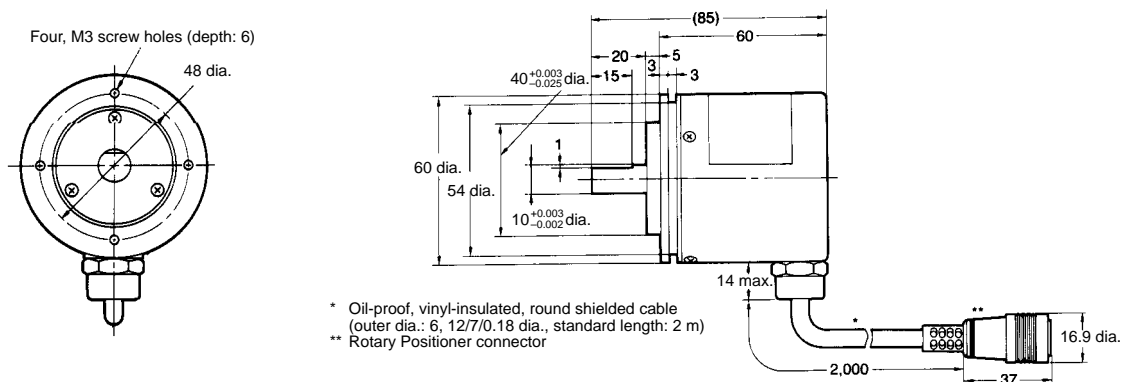

ALL DIMENSIONS SHOWN ARE IN MILLIMETERS.

To convert millimeters into inches, multiply by 0.03937. To convert grams into ounces, multiply by 0.03527.

Cat. No. M040-E1-3B In the interest of product improvement, specifications are subject to change without notice.

OMRON Corporation

Industrial Automation Company

Measuring and Supervisory Controls Division
28th Fl., Crystal Tower Bldg.,
1-2-27, Shiromi, Chuo-ku,
Osaka 540-6028 Japan
Phone: (81)6-6949-6035 Fax: (81)6-6949-6069

Printed in Japan
0499-0.5C (0499)